International Physics Olympiad (IPhO) 1967-2010

Problems and Solutions

Compiled & edited by
scrounghound

Visitors

- [Home](#)
- [Announcements](#)
- [International Board](#)
- [Statutes](#)
- [Syllabus](#)
- [Participants](#)
- [Last Olympiad](#)
- [Next Olympiad](#)
- [Past and Future Organizers](#)
- [Minutes](#)
- [Statistics](#)
- [History](#)
 - [Past Presidents and Secretaries](#)
 - [IPhO History](#)
 - [Memorial to Dr. Waldemar Gorzkowski \(1937-2007\)](#)
- [Literature](#)
- [Past IPhO Problems and Solutions](#)
- [Links](#)
- [Contact](#)

Syllabus

Appendix to the Statutes of the International Physics Olympiads

General

- a. The extensive use of the calculus (differentiation and integration) and the use of complex numbers or solving differential equations should not be required to solve the theoretical and practical problems.
- b. Questions may contain concepts and phenomena not contained in the Syllabus but sufficient information must be given in the questions so that candidates without previous knowledge of these topics would not be at a disadvantage.
- c. Sophisticated practical equipment likely to be unfamiliar to the candidates should not dominate a problem. If such devices are used then careful instructions must be given to the candidates.
- d. The original texts of the problems have to be set in the SI units.

A. Theoretical Part

The first column contains the main entries while the second column contains comments and remarks if necessary.

1. Mechanics

a) Foundation of kinematics of a point mass	Vector description of the position of the point mass, velocity and acceleration as vectors
b) Newton's laws, inertial systems	Problems may be set on changing mass
c) Closed and open systems, momentum and energy, work, power	
d) Conservation of energy, conservation of linear momentum, impulse	
e) Elastic forces, frictional forces, the law of gravitation, potential energy and work in a gravitational field	Hooke's law, coefficient of friction ($F/R = \text{const}$), frictional forces, static and kinetic, choice of zero of potential energy
f) Centripetal acceleration, Kepler's laws	

2. Mechanics of Rigid Bodies

a) Statics, center of mass, torque	Couples, conditions of equilibrium of bodies
b) Motion of rigid bodies, translation, rotation, angular velocity, angular acceleration, conservation of angular momentum	Conservation of angular momentum about fixed axis only
c) External and internal forces, equation of motion of a rigid body around the fixed axis, moment of inertia, kinetic energy of a rotating body	Parallel axes theorem (Steiner's theorem), additivity of the moment of inertia
d) Accelerated reference systems, inertial forces	Knowledge of the Coriolis force formula is not required

3. Hydromechanics

No specific questions will be set on this but students would be expected to know the elementary concepts of pressure, buoyancy and the continuity law.

4. Thermodynamics and Molecular Physics

a) Internal energy, work and heat, first and second laws of thermodynamics	Thermal equilibrium, quantities depending on state and quantities depending on process
b) Model of a perfect gas, pressure and molecular kinetic energy, Avogadro's number, equation of state of a perfect gas, absolute temperature	Also molecular approach to such simple phenomena in liquids and solids as boiling, melting etc.
c) Work done by an expanding gas limited to isothermal and adiabatic processes	Proof of the equation of the adiabatic process is not required
d) The Carnot cycle, thermodynamic efficiency, reversible and irreversible processes, entropy (statistical approach), Boltzmann factor	Entropy as a path independent function, entropy changes and reversibility, quasistatic processes

5. Oscillations and waves

a) Harmonic oscillations, equation of harmonic oscillation	Solution of the equation for harmonic motion, attenuation and resonance - qualitatively
b) Harmonic waves, propagation of waves, transverse and longitudinal waves, linear polarization, the classical Doppler effect, sound waves	Displacement in a progressive wave and understanding of graphical representation of the wave, measurements of velocity of sound and light, Doppler effect in one dimension only, propagation of waves in homogeneous

	and isotropic media, reflection and refraction, Fermat's principle
c) Superposition of harmonic waves, coherent waves, interference, beats, standing waves	Realization that intensity of wave is proportional to the square of its amplitude. Fourier analysis is not required but candidates should have some understanding that complex waves can be made from addition of simple sinusoidal waves of different frequencies. Interference due to thin films and other simple systems (final formulae are not required), superposition of waves from secondary sources (diffraction)

6. Electric Charge and Electric Field

a) Conservation of charge, Coulomb's law	
b) Electric field, potential, Gauss' law	Gauss' law confined to simple symmetric systems like sphere, cylinder, plate etc., electric dipole moment
c) Capacitors, capacitance, dielectric constant, energy density of electric field	

7. Current and Magnetic Field

a) Current, resistance, internal resistance of source, Ohm's law, Kirchhoff's laws, work and power of direct and alternating currents, Joule's law	Simple cases of circuits containing non-ohmic devices with known V-I characteristics
b) Magnetic field (B) of a current, current in a magnetic field, Lorentz force	Particles in a magnetic field, simple applications like cyclotron, magnetic dipole moment
c) Ampere's law	Magnetic field of simple symmetric systems like straight wire, circular loop and long solenoid
d) Law of electromagnetic induction, magnetic flux, Lenz's law, self-induction, inductance, permeability, energy density of magnetic field	
e) Alternating current, resistors, inductors and capacitors in AC-circuits, voltage and current (parallel and series) resonances	Simple AC-circuits, time constants, final formulae for parameters of concrete resonance circuits are not required

8. Electromagnetic waves

a) Oscillatory circuit, frequency of oscillations, generation by feedback and resonance	
b) Wave optics, diffraction from one and two slits, diffraction grating, resolving power of a grating, Bragg reflection,	
c) Dispersion and diffraction spectra, line spectra of gases	
d) Electromagnetic waves as transverse waves, polarization by reflection, polarizers	Superposition of polarized waves
e) Resolving power of imaging systems	
f) Black body, Stefan-Boltzmann's law	Planck's formula is not required

9. Quantum Physics

a) Photoelectric effect, energy and impulse of the photon	Einstein's formula is required
b) De Broglie wavelength, Heisenberg's uncertainty principle	

10. Relativity

a) Principle of relativity, addition of velocities, relativistic Doppler effect	
b) Relativistic equation of motion, momentum, energy, relation between energy and mass, conservation of energy and momentum	

11. Matter

a) Simple applications of the Bragg equation	
b) Energy levels of atoms and molecules (qualitatively), emission, absorption, spectrum of hydrogen like atoms	
c) Energy levels of nuclei (qualitatively), alpha-, beta- and gamma-decays, absorption of radiation, half-life and exponential decay, components of nuclei, mass defect, nuclear reactions	

B. Practical Part

The Theoretical Part of the Syllabus provides the basis for all the experimental problems. The experimental problems given in the experimental contest should contain measurements.

Additional requirements:

1. Candidates must be aware that instruments affect measurements.
2. Knowledge of the most common experimental techniques for measuring physical quantities mentioned in Part A.
3. Knowledge of commonly used simple laboratory instruments and devices such as calipers, thermometers, simple volt-, ohm- and ammeters, potentiometers, diodes, transistors, simple optical devices and so on.
4. Ability to use, with the help of proper instruction, some sophisticated instruments and devices such as double-beam oscilloscope, counter, ratemeter, signal and function generators, analog-to-digital converter connected to a computer, amplifier, integrator, differentiator, power supply, universal (analog and digital) volt-, ohm- and ammeters.
5. Proper identification of error sources and estimation of their influence on the final result(s).
6. Absolute and relative errors, accuracy of measuring instruments, error of a single measurement, error of a series of measurements, error of a quantity given as a function of measured quantities.
7. Transformation of a dependence to the linear form by appropriate choice of variables and fitting a straight line to experimental points.
8. Proper use of the graph paper with different scales (for example polar and logarithmic papers).
9. Correct rounding off and expressing the final result(s) and error(s) with correct number of significant digits.
10. Standard knowledge of safety in laboratory work. (Nevertheless, if the experimental set-up contains any safety hazards the appropriate warnings should be included into the text of the problem.)

Problems of the 1st International Physics Olympiad¹ (Warsaw, 1967)

Waldemar Gorzkowski

Institute of Physics, Polish Academy of Sciences, Warsaw, Poland²

Abstract

The article contains the competition problems given at the 1st International Physics Olympiad (Warsaw, 1967) and their solutions. Additionally it contains comments of historical character.

Introduction

One of the most important points when preparing the students to the International Physics Olympiads is solving and analysis of the competition problems given in the past. Unfortunately, it is very difficult to find appropriate materials. The proceedings of the subsequent Olympiads are published starting from the XV IPhO in Sigtuna (Sweden, 1984). It is true that some of very old problems were published (not always in English) in different books or articles, but they are practically unavailable. Moreover, sometimes they are more or less substantially changed.

The original English versions of the problems of the 1st IPhO have not been conserved. The permanent Secretariat of the IPhOs was created in 1983. Until this year the Olympic materials were collected by different persons in their private archives. These archives as a rule were of amateur character and practically no one of them was complete. This article is based on the books by R. Kunfalvi [1], Tadeusz Pniewski [2] and Waldemar Gorzkowski [3]. Tadeusz Pniewski was one of the members of the Organizing Committee of the Polish Physics Olympiad when the 1st IPhO took place, while R. Kunfalvi was one of the members of the International Board at the 1st IPhO. For that it seems that credibility of these materials is very high. The differences between versions presented by R. Kunfalvi and T. Pniewski are rather very small (although the book by Pniewski is richer, especially with respect to the solution to the experimental problem).

As regards the competition problems given in Sigtuna (1984) or later, they are available, in principle, in appropriate proceedings. "In principle" as the proceedings usually were published in a small number of copies, not enough to satisfy present needs of people interested in our competition. It is true that every year the organizers provide the permanent Secretariat with a number of copies of the proceedings for free dissemination. But the needs are continually growing up and we have disseminated practically all what we had.

The competition problems were commonly available (at least for some time) just only from the XXVI IPhO in Canberra (Australia) as from that time the organizers started putting the problems on their home pages. The Olympic home page www.jyu.fi/ipho contains the problems starting from the XXVIII IPhO in Sudbury (Canada). Unfortunately, the problems given in Canberra (XXVI IPhO) and in Oslo (XXVII IPhO) are not present there.

The net result is such that finding the competition problems of the Olympiads organized prior to Sudbury is very difficult. It seems that the best way of improving the situation is publishing the competition problems of the older Olympiads in our journal. The

¹ This is somewhat extended version of the article sent for publication in *Physics Competitions* in July 2003.

² e-mail: gorzk@ifpan.edu.pl

question arises, however, who should do it. According to the Statutes the problems are created by the local organizing committees. It is true that the texts are improved and accepted by the International Board, but always the organizers bear the main responsibility for the topics of the problems, their structure and quality. On the other hand, the glory resulting of high level problems goes to them. For the above it is absolutely clear to me that they should have an absolute priority with respect to any form of publication. So, the best way would be to publish the problems of the older Olympiads by representatives of the organizers from different countries.

Poland organized the IPhOs for three times: I IPhO (1967), VII IPhO (1974) and XX IPhO (1989). So, I have decided to give a good example and present the competition problems of these Olympiads in three subsequent articles. At the same time I ask our Colleagues and Friends from other countries for doing the same with respect to the Olympiads organized in their countries prior to the XXVIII IPhO (Sudbury).

I IPhO (Warsaw 1967)

The problems were created by the Organizing Committee. At present we are not able to recover the names of the authors of the problems.

Theoretical problems

Problem 1

A small ball with mass $M = 0.2$ kg rests on a vertical column with height $h = 5$ m. A bullet with mass $m = 0.01$ kg, moving with velocity $v_0 = 500$ m/s, passes horizontally through the center of the ball (Fig. 1). The ball reaches the ground at a distance $s = 20$ m. Where does the bullet reach the ground? What part of the kinetic energy of the bullet was converted into heat when the bullet passed through the ball? Neglect resistance of the air. Assume that $g = 10$ m/s².

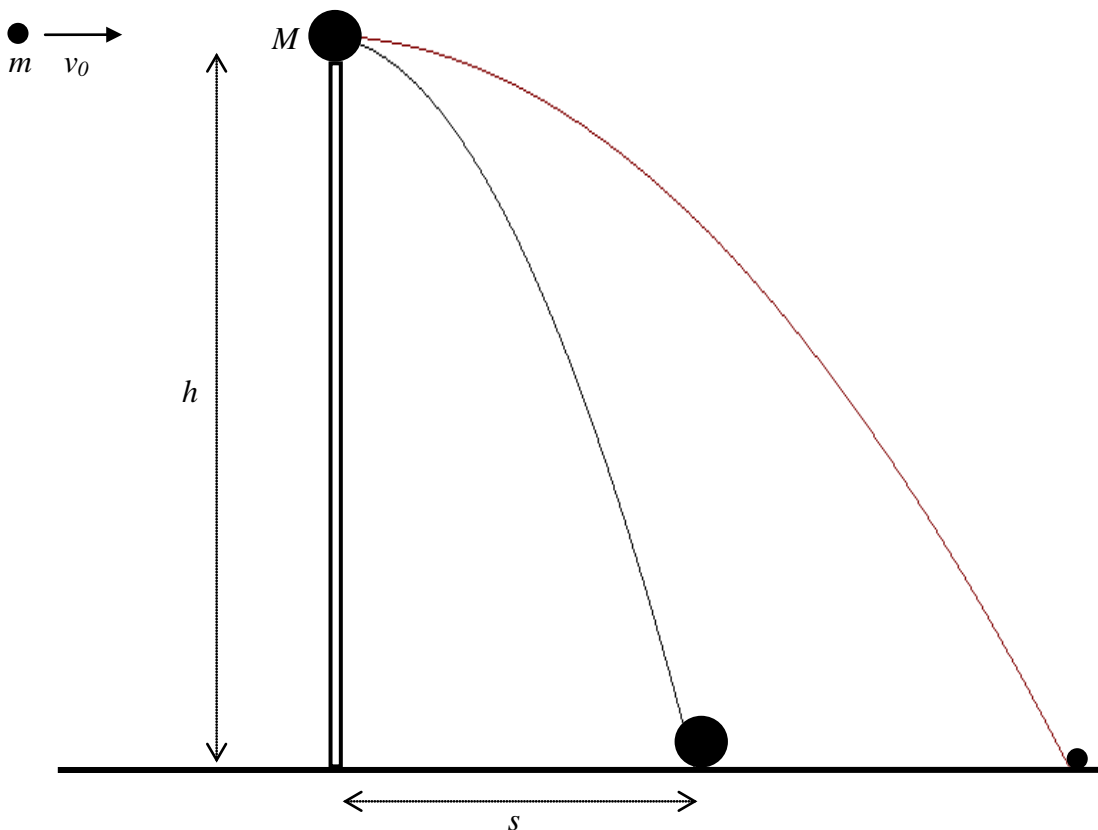

Fig. 1

Solution

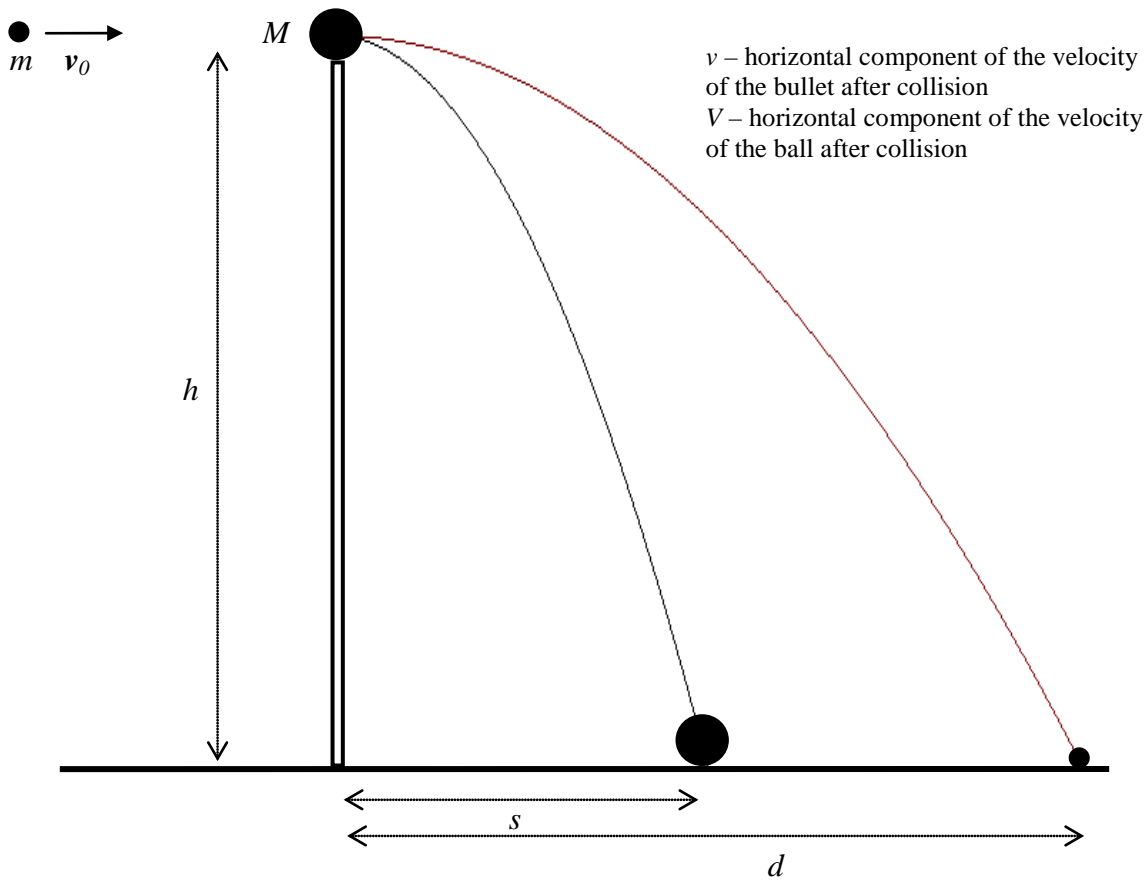

Fig. 2

We will use notation shown in Fig. 2.

As no horizontal force acts on the system ball + bullet, the horizontal component of momentum of this system before collision and after collision must be the same:

$$mv_0 = mv + MV.$$

So,

$$v = v_0 - \frac{M}{m}V.$$

From conditions described in the text of the problem it follows that

$$v > V.$$

After collision both the ball and the bullet continue a free motion in the gravitational field with initial horizontal velocities v and V , respectively. Motion of the ball and motion of the bullet are continued for the same time:

$$t = \sqrt{\frac{2h}{g}}.$$

It is time of free fall from height h .

The distances passed by the ball and bullet during time t are:

$$s = Vt \quad \text{and} \quad d = vt,$$

respectively. Thus

$$V = s\sqrt{\frac{g}{2h}}.$$

Therefore

$$v = v_0 - \frac{M}{m}s\sqrt{\frac{g}{2h}}.$$

Finally:

$$d = v_0\sqrt{\frac{2h}{g}} - \frac{M}{m}s.$$

Numerically:

$$d = 100 \text{ m.}$$

The total kinetic energy of the system was equal to the initial kinetic energy of the bullet:

$$E_0 = \frac{mv_0^2}{2}.$$

Immediately after the collision the total kinetic energy of the system is equal to the sum of the kinetic energy of the bullet and the ball:

$$E_m = \frac{mv^2}{2}, \quad E_M = \frac{MV^2}{2}.$$

Their difference, converted into heat, was

$$\Delta E = E_0 - (E_m + E_M).$$

It is the following part of the initial kinetic energy of the bullet:

$$p = \frac{\Delta E}{E_0} = 1 - \frac{E_m + E_M}{E_0}.$$

By using expressions for energies and velocities (quoted earlier) we get

$$p = \frac{M}{m} \frac{s^2}{v_0^2} \frac{g}{2h} \left(2 \frac{v_0}{s} \sqrt{\frac{2h}{g}} - \frac{M+m}{m} \right).$$

Numerically:

$$p = 92,8\%.$$

Problem 2

Consider an infinite network consisting of resistors (resistance of each of them is r) shown in Fig. 3. Find the resultant resistance R_{AB} between points A and B.

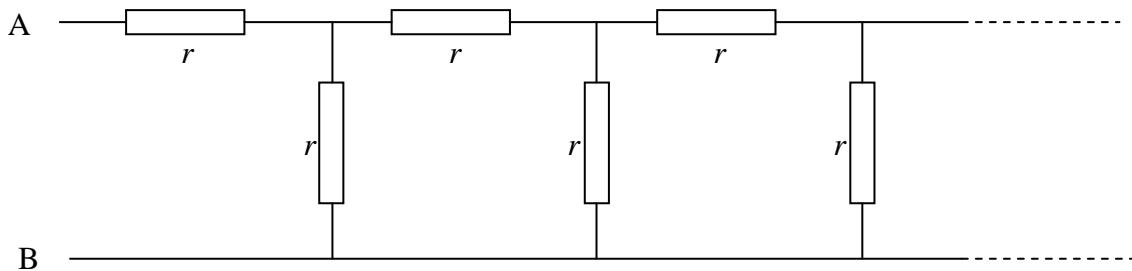

Fig. 3

Solution

It is easy to remark that after removing the left part of the network, shown in Fig. 4 with the dotted square, then we receive a network that is identical with the initial network (it is result of the fact that the network is infinite).

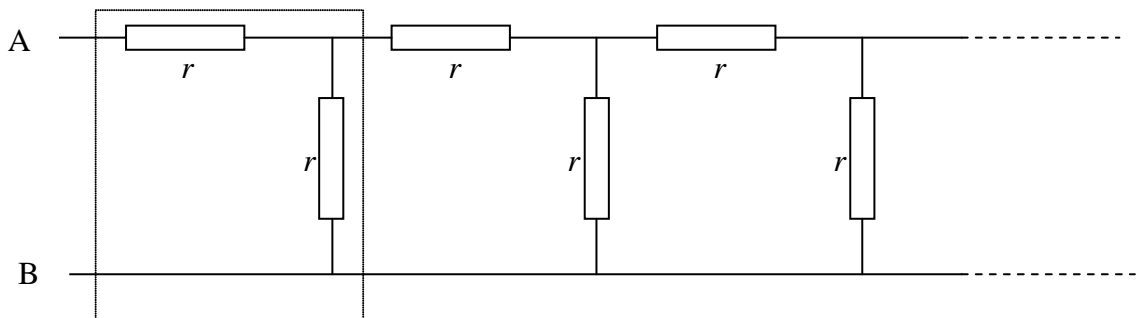

Fig. 4

Thus, we may use the equivalence shown graphically in Fig. 5.

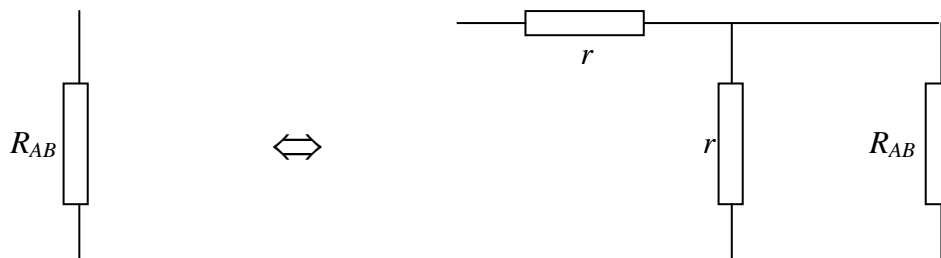

Fig. 5

Algebraically this equivalence can be written as

$$R_{AB} = r + \frac{1}{\frac{1}{r} + \frac{1}{R_{AB}}}.$$

Thus

$$R_{AB}^2 - rR_{AB} - r^2 = 0.$$

This equation has two solutions:

$$R_{AB} = \frac{1}{2}(1 \pm \sqrt{5})r.$$

The solution corresponding to “-“ in the above formula is negative, while resistance must be positive. So, we reject it. Finally we receive

$$R_{AB} = \frac{1}{2}(1 + \sqrt{5})r.$$

Problem 3

Consider two identical homogeneous balls, A and B, with the same initial temperatures. One of them is at rest on a horizontal plane, while the second one hangs on a thread (Fig. 6). The same quantities of heat have been supplied to both balls. Are the final temperatures of the balls the same or not? Justify your answer. (All kinds of heat losses are negligible.)



Fig. 6

Solution



Fig. 7

As regards the text of the problem, the sentence “The same quantities of heat have been supplied to both balls.” is not too clear. We will follow intuitive understanding of this

sentence, i.e. we will assume that both systems (A – the hanging ball and B – the ball resting on the plane) received the same portion of energy from outside. One should realize, however, that it is not the only possible interpretation.

When the balls are warmed up, their mass centers are moving as the radii of the balls are changing. The mass center of the ball A goes down, while the mass center of the ball B goes up. It is shown in Fig. 7 (scale is not conserved).

Displacement of the mass center corresponds to a change of the potential energy of the ball in the gravitational field.

In case of the ball A the potential energy decreases. From the 1st principle of thermodynamics it corresponds to additional heating of the ball.

In case of the ball B the potential energy increases. From the 1st principle of thermodynamics it corresponds to some “losses of the heat provided” for performing a mechanical work necessary to rise the ball. The net result is that the final temperature of the ball B should be lower than the final temperature of the ball A.

The above effect is very small. For example, one may find (see later) that for balls made of lead, with radius 10 cm, and portion of heat equal to 50 kcal, the difference of the final temperatures of the balls is of order 10^{-5} K. For spatial and time fluctuations such small quantity practically cannot be measured.

Calculation of the difference of the final temperatures was not required from the participants. Nevertheless, we present it here as an element of discussion.

We may assume that the work against the atmospheric pressure can be neglected. It is obvious that this work is small. Moreover, it is almost the same for both balls. So, it should not affect the difference of the temperatures substantially. We will assume that such quantities as specific heat of lead and coefficient of thermal expansion of lead are constant (i.e. do not depend on temperature).

The heat used for changing the temperatures of balls may be written as

$$Q_i = mc\Delta t_i, \quad \text{where } i = A \text{ or } B,$$

Here: m denotes the mass of ball, c - the specific heat of lead and Δt_i - the change of the temperature of ball.

The changes of the potential energy of the balls are (neglecting signs):

$$\Delta E_i = mgr\alpha\Delta t_i, \quad \text{where } i = A \text{ or } B.$$

Here: g denotes the gravitational acceleration, r - initial radius of the ball, α - coefficient of thermal expansion of lead. We assume here that the thread does not change its length.

Taking into account conditions described in the text of the problem and the interpretation mentioned at the beginning of the solution, we may write:

$$\begin{aligned} Q &= Q_A - A\Delta E_A, \quad \text{for the ball } A, \\ Q &= Q_B + A\Delta E_B, \quad \text{for the ball } B. \end{aligned}$$

A denotes the thermal equivalent of work: $A \approx 0.24 \frac{\text{cal}}{\text{J}}$. In fact, A is only a conversion ratio between calories and joules. If you use a system of units in which calories are not present, you may omit A at all.

Thus

$$Q = (mc - Amgr\alpha)\Delta t_A, \text{ for the ball } A,$$

$$Q = (mc + Amgr\alpha)\Delta t_B, \text{ for the ball } B$$

and

$$\Delta t_A = \frac{Q}{mc - Amgr\alpha}, \quad \Delta t_B = \frac{Q}{mc + Amgr\alpha}.$$

Finally we get

$$\Delta t = \Delta t_A - \Delta t_B = \frac{2Agr\alpha}{c^2 - (Agr\alpha)^2} \frac{Q}{m} \approx \frac{2AQgr\alpha}{mc^2}.$$

(We neglected the term with α^2 as the coefficient α is very small.)

Now we may put the numerical values: $Q = 50$ kcal, $A \approx 0.24$ cal/J, $g \approx 9.8$ m/s², $m \approx 47$ kg (mass of the lead ball with radius equal to 10 cm), $r = 0.1$ m, $c \approx 0.031$ cal/(g·K), $\alpha \approx 29 \cdot 10^{-6}$ K⁻¹. After calculations we get $\Delta t \approx 1.5 \cdot 10^{-5}$ K.

Problem 4

Comment: The Organizing Committee prepared three theoretical problems. Unfortunately, at the time of the 1st Olympiad the Romanian students from the last class had the entrance examinations at the universities. For that Romania sent a team consisting of students from younger classes. They were not familiar with electricity. To give them a chance the Organizers (under agreement of the International Board) added the fourth problem presented here. The students (not only from Romania) were allowed to chose three problems. The maximum possible scores for the problems were: 1st problem – 10 points, 2nd problem – 10 points, 3rd problem – 10 points and 4th problem – 6 points. The fourth problem was solved by 8 students. Only four of them solved the problem for 6 points.

A closed vessel with volume $V_0 = 10$ l contains dry air in the normal conditions ($t_0 = 0^\circ\text{C}$, $p_0 = 1$ atm). In some moment 3 g of water were added to the vessel and the system was warmed up to $t = 100^\circ\text{C}$. Find the pressure in the vessel. Discuss assumption you made to solve the problem.

Solution

The water added to the vessel evaporates. Assume that the whole portion of water evaporated. Then the density of water vapor in 100°C should be 0.300 g/l. It is less than the density of saturated vapor at 100°C equal to 0.597 g/l. (The students were allowed to use physical tables.) So, at 100°C the vessel contains air and unsaturated water vapor only (without any liquid phase).

Now we assume that both air and unsaturated water vapor behave as ideal gases. In view of Dalton law, the total pressure p in the vessel at 100°C is equal to the sum of partial pressures of the air p_a and unsaturated water vapor p_v :

$$p = p_a + p_v.$$

As the volume of the vessel is constant, we may apply the Gay-Lussac law to the air. We obtain:

$$p_a = p_0 \left(\frac{273+t}{273} \right).$$

The pressure of the water vapor may be found from the equation of state of the ideal gas:

$$\frac{p_v V_0}{273+t} = \frac{m}{\mu} R,$$

where m denotes the mass of the vapor, μ - the molecular mass of the water and R - the universal gas constant. Thus,

$$p_v = \frac{m}{\mu} R \frac{273+t}{V_0}$$

and finally

$$p = p_0 \frac{273+t}{273} + \frac{m}{\mu} R \frac{273+t}{V_0}.$$

Numerically:

$$p = (1.366 + 0.516) \text{ atm} \approx 1.88 \text{ atm}.$$

Experimental problem

The following devices and materials are given:

1. Balance (without weights)
2. Calorimeter
3. Thermometer
4. Source of voltage
5. Switches
6. Wires
7. Electric heater
8. Stop-watch
9. Beakers
10. Water
11. Petroleum
12. Sand (for balancing)

Determine specific heat of petroleum. The specific heat of water is $1 \text{ cal}/(\text{g}\cdot^\circ\text{C})$. The specific heat of the calorimeter is $0.092 \text{ cal}/(\text{g}\cdot^\circ\text{C})$.

Discuss assumptions made in the solution.

Solution

The devices given to the students allowed using several methods. The students used the following three methods:

1. Comparison of velocity of warming up water and petroleum;
2. Comparison of cooling down water and petroleum;
3. Traditional heat balance.

As no weights were given, the students had to use the sand to find portions of petroleum and water with masses equal to the mass of calorimeter.

First method: comparison of velocity of warming up

If the heater is inside water then both water and calorimeter are warming up. The heat taken by water and calorimeter is:

$$Q_1 = m_w c_w \Delta t_1 + m_c c_c \Delta t_1,$$

where: m_w denotes mass of water, m_c - mass of calorimeter, c_w - specific heat of water, c_c - specific heat of calorimeter, Δt_1 - change of temperature of the system water + calorimeter.

On the other hand, the heat provided by the heater is equal:

$$Q_2 = A \frac{U^2}{R} \tau_1,$$

where: A – denotes the thermal equivalent of work, U – voltage, R – resistance of the heater, τ_1 – time of work of the heater in the water.

Of course,

$$Q_1 = Q_2.$$

Thus

$$A \frac{U^2}{R} \tau_1 = m_w c_w \Delta t_1 + m_c c_c \Delta t_1.$$

For petroleum in the calorimeter we get a similar formula:

$$A \frac{U^2}{R} \tau_2 = m_p c_p \Delta t_2 + m_c c_c \Delta t_2.$$

where: m_p denotes mass of petroleum, c_p - specific heat of petroleum, Δt_2 - change of temperature of the system water + petroleum, τ_2 – time of work of the heater in the petroleum.

By dividing the last equations we get

$$\frac{\tau_1}{\tau_2} = \frac{m_w c_w \Delta t_1 + m_c c_c \Delta t}{m_p c_p \Delta t_2 + m_c c_c \Delta t_2}.$$

It is convenient to perform the experiment by taking masses of water and petroleum equal to the mass of the calorimeter (for that we use the balance and the sand). For

$$m_w = m_p = m_c$$

the last formula can be written in a very simple form:

$$\frac{\tau_1}{\tau_2} = \frac{c_w \Delta t_1 + c_c \Delta t_1}{c_p \Delta t_2 + c_c \Delta t_2}.$$

Thus

$$c_c = \frac{\Delta t_1}{\tau_1} \frac{\tau_2}{\Delta t_2} c_w - \left(1 - \frac{\Delta t_1}{\tau_1} \frac{\tau_2}{\Delta t_2} \right) c_c$$

or

$$c_c = \frac{k_1}{k_2} c_w - \left(1 - \frac{k_1}{k_2} \right) c_c,$$

where

$$k_1 = \frac{\Delta t_1}{\tau_1} \quad \text{and} \quad k_2 = \frac{\Delta t_2}{\tau_2}$$

denote “velocities of heating” water and petroleum, respectively. These quantities can be determined experimentally by drawing graphs representing dependence Δt_1 and Δt_2 on time (τ). The experiment shows that these dependences are linear. Thus, it is enough to take slopes of appropriate straight lines. The experimental setup given to the students allowed measurements of the specific heat of petroleum, equal to 0.53 cal/(g $^\circ$ C), with accuracy about 1%.

Some students used certain mutations of this method by performing measurements at $\Delta t_1 = \Delta t_2$ or at $\tau_1 = \tau_2$. Then, of course, the error of the final result is greater (it is additionally affected by accuracy of establishing the conditions $\Delta t_1 = \Delta t_2$ or at $\tau_1 = \tau_2$).

Second method: comparison of velocity of cooling down

Some students initially heated the liquids in the calorimeter and later observed their cooling down. This method is based on the Newton’s law of cooling. It says that the heat Q transferred during cooling in time τ is given by the formula:

$$Q = h(t - \vartheta) s \tau,$$

where: t denotes the temperature of the body, ϑ - the temperature of surrounding, s – area of the body, and h – certain coefficient characterizing properties of the surface. This formula is

correct for small differences of temperatures $t - \vartheta$ only (small compared to t and ϑ in the absolute scale).

This method, like the previous one, can be applied in different versions. We will consider only one of them.

Consider the situation when cooling of water and petroleum is observed in the same calorimeter (containing initially water and later petroleum). The heat lost by the system water + calorimeter is

$$\Delta Q_1 = (m_w c_w + m_c c_c) \Delta t ,$$

where Δt denotes a change of the temperature of the system during certain period τ_1 . For the system petroleum + calorimeter, under assumption that the change in the temperature Δt is the same, we have

$$\Delta Q_2 = (m_p c_p + m_c c_c) \Delta t .$$

Of course, the time corresponding to Δt in the second case will be different. Let it be τ_2 .

From the Newton's law we get

$$\frac{\Delta Q_1}{\Delta Q_2} = \frac{\tau_1}{\tau_2} .$$

Thus

$$\frac{\tau_1}{\tau_2} = \frac{m_w c_w + m_c c_c}{m_p c_p + m_c c_c} .$$

If we conduct the experiment at

$$m_w = m_p = m_c ,$$

then we get

$$c_p = \frac{T_2}{T_1} c_w - \left(1 - \frac{T_2}{T_1} \right) c_c .$$

As cooling is rather a very slow process, this method gives the result with definitely greater error.

Third method: heat balance

This method is rather typical. The students heated the water in the calorimeter to certain temperature t_1 and added the petroleum with the temperature t_2 . After reaching the thermal equilibrium the final temperature was t . From the thermal balance (neglecting the heat losses) we have

$$(m_w c_w + m_c c_c)(t_1 - t) = m_p c_p (t - t_2).$$

If, like previously, the experiment is conducted at

$$m_w = m_p = m_c,$$

then

$$c_p = (c_w + c_c) \frac{t_1 - t}{t - t_2}.$$

In this methods the heat losses (when adding the petroleum to the water) always played a substantial role.

The accuracy of the result equal or better than 5% can be reached by using any of the methods described above. However, one should remark that in the first method it was easiest. The most common mistake was neglecting the heat capacity of the calorimeter. This mistake increased the error additionally by about 8%.

Marks

No marking schemes are present in my archive materials. Only the mean scores are available. They are:

Problem # 1	7.6 points
Problem # 2	7.8 points (without the Romanian students)
Problem # 3	5.9 points
Experimental problem	7.7 points

Thanks

The author would like to express deep thanks to Prof. Jan Mostowski and Dr. Yohanes Surya for reviewing the text and for valuable comments and remarks.

Literature

- [1] **R. Kunfalvi**, *Collection of Competition Tasks from the Ist trough XVth International Physics Olympiads, 1967 – 1984*, Roland Eotvos Physical Society and UNESCO, Budapest 1985
- [2] **Tadeusz Pniewski**, *Olimpiady Fizyczne: XV i XVI*, PZWS, Warszawa 1969
- [3] **Waldemar Gorzkowski**, *Zadania z fizyki z całego świata (z rozwiązaniami) - 20 lat Międzynarodowych Olimpiad Fizycznych*, WNT, Warszawa 1994 [ISBN 83-204-1698-1]

Problems of the 2nd International Physics Olympiads (Budapest, Hungary, 1968)

Péter Vankó

Institute of Physics, Budapest University of Technical Engineering, Budapest, Hungary

Abstract

After a short introduction the problems of the 2nd and the 9th International Physics Olympiad, organized in Budapest, Hungary, 1968 and 1976, and their solutions are presented.

Introduction

Following the initiative of Dr. Waldemar Gorzkowski [1] I present the problems and solutions of the 2nd and the 9th International Physics Olympiad, organized by Hungary. I have used Prof. Rezső Kunfalvi's problem collection [2], its Hungarian version [3] and in the case of the 9th Olympiad the original Hungarian problem sheet given to the students (my own copy). Besides the digitalization of the text, the equations and the figures it has been made only small corrections where it was needed (type mistakes, small grammatical changes). I omitted old units, where both old and SI units were given, and converted them into SI units, where it was necessary.

If we compare the problem sheets of the early Olympiads with the last ones, we can realize at once the difference in length. It is not so easy to judge the difficulty of the problems, but the solutions are surely much shorter.

The problems of the 2nd Olympiad followed the more than hundred years tradition of physics competitions in Hungary. The tasks of the most important Hungarian theoretical physics competition (Eötvös Competition), for example, are always very short. Sometimes the solution is only a few lines, too, but to find the idea for this solution is rather difficult.

Of the 9th Olympiad I have personal memories; I was the youngest member of the Hungarian team. The problems of this Olympiad were collected and partly invented by Miklós Vermes, a legendary and famous Hungarian secondary school physics teacher. In the first problem only the detailed investigation of the stability was unusual, in the second problem one could forget to subtract the work of the atmospheric pressure, but the fully "open" third problem was really unexpected for us.

The experimental problem was difficult in the same way: in contrast to the Olympiads of today we got no instructions how to measure. (In the last years the only similarly open experimental problem was the investigation of "The magnetic puck" in Leicester, 2000, a really nice problem by Cyril Isenberg.) The challenge was not to perform many-many measurements in a short time, but to find out what to measure and how to do it.

Of course, the evaluating of such open problems is very difficult, especially for several hundred students. But in the 9th Olympiad, for example, only ten countries participated and the same person could read, compare, grade and mark all of the solutions.

2nd IPhO (Budapest, 1968)

Theoretical problems

Problem 1

On an inclined plane of 30° a block, mass $m_2 = 4$ kg, is joined by a light cord to a solid cylinder, mass $m_1 = 8$ kg, radius $r = 5$ cm (Fig. 1). Find the acceleration if the bodies are released. The coefficient of friction between the block and the inclined plane $\mu = 0.2$. Friction at the bearing and rolling friction are negligible.

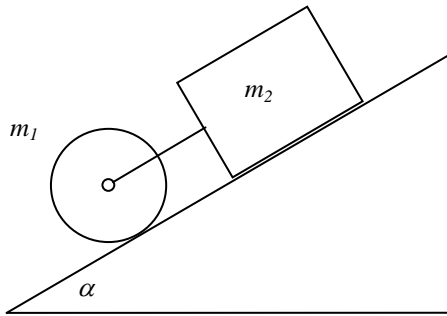

Figure 1

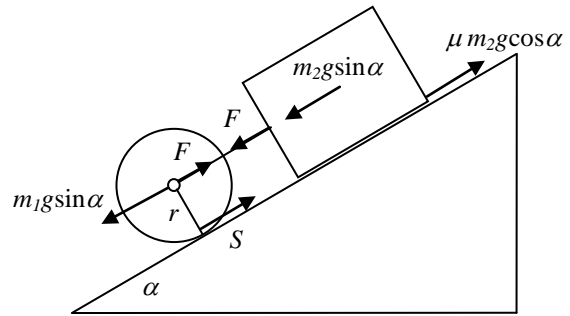

Figure 2

Solution

If the cord is stressed the cylinder and the block are moving with the same acceleration a . Let F be the tension in the cord, S the frictional force between the cylinder and the inclined plane (Fig. 2). The angular acceleration of the cylinder is a/r . The net force causing the acceleration of the block:

$$m_2 a = m_2 g \sin \alpha - \mu m_2 g \cos \alpha + F,$$

and the net force causing the acceleration of the cylinder:

$$m_1 a = m_1 g \sin \alpha - S - F.$$

The equation of motion for the rotation of the cylinder:

$$S r = \frac{a}{r} \cdot I.$$

(I is the moment of inertia of the cylinder, $S \cdot r$ is the torque of the frictional force.)

Solving the system of equations we get:

$$a = g \cdot \frac{(m_1 + m_2) \sin \alpha - \mu m_2 \cos \alpha}{m_1 + m_2 + \frac{I}{r^2}}, \quad (1)$$

$$S = \frac{I}{r^2} \cdot g \cdot \frac{(m_1 + m_2) \sin \alpha - \mu m_2 \cos \alpha}{m_1 + m_2 + \frac{I}{r^2}}, \quad (2)$$

$$F = m_2 g \cdot \frac{\mu \left(m_1 + \frac{I}{r^2} \right) \cos \alpha - \frac{I \sin \alpha}{r^2}}{m_1 + m_2 + \frac{I}{r^2}}. \quad (3)$$

The moment of inertia of a solid cylinder is $I = \frac{m_1 r^2}{2}$. Using the given numerical values:

$$a = g \cdot \frac{(m_1 + m_2) \sin \alpha - \mu m_2 \cos \alpha}{1.5 m_1 + m_2} = 0.3317 g = \mathbf{3.25 \text{ m/s}^2},$$

$$S = \frac{m_1 g}{2} \cdot \frac{(m_1 + m_2) \sin \alpha - \mu m_2 \cos \alpha}{1.5 m_1 + m_2} = \mathbf{13.01 \text{ N}},$$

$$F = m_2 g \cdot \frac{(1.5 \mu \cos \alpha - 0.5 \sin \alpha) m_1}{1.5 m_1 + m_2} = \mathbf{0.192 \text{ N}}.$$

Discussion (See Fig. 3.)

The condition for the system to start moving is $a > 0$. Inserting $a = 0$ into (1) we obtain the limit for angle α_1 :

$$\tan \alpha_1 = \mu \cdot \frac{m_2}{m_1 + m_2} = \frac{\mu}{3} = 0.0667, \quad \alpha_1 = 3.81^\circ.$$

For the cylinder separately $\alpha_1 = 0$, and for the block separately $\alpha_1 = \tan^{-1} \mu = 11.31^\circ$.

If the cord is not stretched the bodies move separately. We obtain the limit by inserting $F = 0$ into (3):

$$\tan \alpha_2 = \mu \cdot \left(1 + \frac{m_1 r^2}{I} \right) = 3\mu = 0.6, \quad \alpha_2 = 30.96^\circ.$$

The condition for the cylinder to slip is that the value of S (calculated from (2) taking the same coefficient of friction) exceeds the value of $\mu m_1 g \cos \alpha$. This gives the same value for α_3 as we had for α_2 . The acceleration of the centers of the cylinder and the block is the same: $g(\sin \alpha - \mu \cos \alpha)$, the frictional force at the bottom of the cylinder is $\mu m_1 g \cos \alpha$, the peripheral acceleration of the cylinder is $\mu \cdot \frac{m_1 r^2}{I} \cdot g \cos \alpha$.

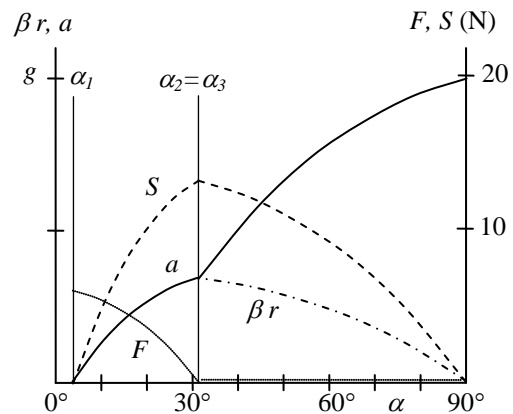

Figure 3

Problem 2

There are 300 cm^3 toluene of 0°C temperature in a glass and 110 cm^3 toluene of 100°C temperature in another glass. (The sum of the volumes is 410 cm^3 .) Find the final volume after the two liquids are mixed. The coefficient of volume expansion of toluene $\beta = 0.001(^\circ\text{C})^{-1}$. Neglect the loss of heat.

Solution

If the volume at temperature t_1 is V_1 , then the volume at temperature 0°C is $V_{10} = V_1 / (1 + \beta t_1)$. In the same way if the volume at t_2 temperature is V_2 , at 0°C we have $V_{20} = V_2 / (1 + \beta t_2)$. Furthermore if the density of the liquid at 0°C is d , then the masses are $m_1 = V_{10}d$ and $m_2 = V_{20}d$, respectively. After mixing the liquids the temperature is

$$t = \frac{m_1 t_1 + m_2 t_2}{m_1 + m_2}.$$

The volumes at this temperature are $V_{10}(1 + \beta t)$ and $V_{20}(1 + \beta t)$.

The sum of the volumes after mixing:

$$\begin{aligned} V_{10}(1 + \beta t) + V_{20}(1 + \beta t) &= V_{10} + V_{20} + \beta(V_{10} + V_{20})t = \\ &= V_{10} + V_{20} + \beta \cdot \frac{m_1 + m_2}{d} \cdot \frac{m_1 t_1 + m_2 t_2}{m_1 + m_2} = \\ &= V_{10} + V_{20} + \beta \left(\frac{m_1 t_1}{d} + \frac{m_2 t_2}{d} \right) = V_{10} + \beta V_{10} t_1 + V_{20} + \beta V_{20} t_2 = \\ &= V_{10}(1 + \beta t_1) + V_{20}(1 + \beta t_2) = V_1 + V_2 \end{aligned}$$

The sum of the volumes is constant. In our case it is 410 cm^3 . The result is valid for any number of quantities of toluene, as the mixing can be done successively adding always one more glass of liquid to the mixture.

Problem 3

Parallel light rays are falling on the plane surface of a semi-cylinder made of glass, at an angle of 45° , in such a plane which is perpendicular to the axis of the semi-cylinder (Fig. 4). (Index of refraction is $\sqrt{2}$.) Where are the rays emerging out of the cylindrical surface?

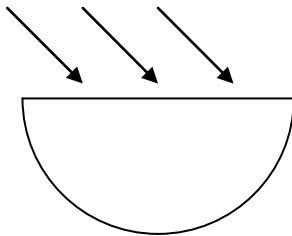

Figure 4

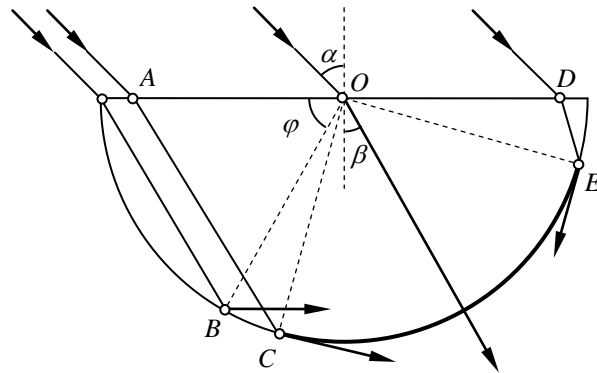

Figure 5

Solution

Let us use angle φ to describe the position of the rays in the glass (Fig. 5). According to the law of refraction $\sin 45^\circ / \sin \beta = \sqrt{2}$, $\sin \beta = 0.5$, $\beta = 30^\circ$. The refracted angle is 30° for all of the incoming rays. We have to investigate what happens if φ changes from 0° to 180° .

It is easy to see that φ can not be less than 60° ($AOB\angle = 60^\circ$). The critical angle is given by $\sin \beta_{crit} = 1/n = \sqrt{2}/2$; hence $\beta_{crit} = 45^\circ$. In the case of total internal reflection $ACO\angle = 45^\circ$, hence $\varphi = 180^\circ - 60^\circ - 45^\circ = 75^\circ$. If φ is more than 75° the rays can emerge the cylinder. Increasing the angle we reach the critical angle again if $OED\angle = 45^\circ$. Thus the rays are leaving the glass cylinder if:

$$75^\circ < \varphi < 165^\circ,$$

CE, arc of the emerging rays, subtends a central angle of 90° .

Experimental problem

Three closed boxes (black boxes) with two plug sockets on each are present for investigation. The participants have to find out, without opening the boxes, what kind of elements are in them and measure their characteristic properties. AC and DC meters (their internal resistance and accuracy are given) and AC (50 Hz) and DC sources are put at the participants' disposal.

Solution

No voltage is observed at any of the plug sockets therefore none of the boxes contains a source.

Measuring the resistances using first AC then DC, one of the boxes gives the same result. Conclusion: the box contains a simple resistor. Its resistance is determined by measurement.

One of the boxes has a very great resistance for DC but conducts AC well. It contains a capacitor, the value can be computed as $C = \frac{1}{\omega X_c}$.

The third box conducts both AC and DC, its resistance for AC is greater. It contains a resistor and an inductor connected in series. The values of the resistance and the inductance can be computed from the measurements.

3rd International Physics Olympiad
1969, Brno, Czechoslovakia

Problem 1. Figure 1 shows a mechanical system consisting of three carts A , B and C of masses $m_1 = 0.3$ kg, $m_2 = 0.2$ kg and $m_3 = 1.5$ kg respectively. Carts B and A are connected by a light taut inelastic string which passes over a light smooth pulley attaches to the cart C as shown. For this problem, all resistive and frictional forces may be ignored as may the moments of inertia of the pulley and of the wheels of all three carts. Take the acceleration due to gravity g to be 9.81 m s⁻².

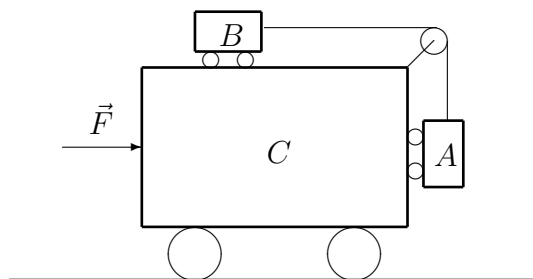

Figure 1:

1. A horizontal force \vec{F} is now applied to cart C as shown. The size of \vec{F} is such that carts A and B remain at rest relative to cart C .
 - a) Find the tension in the string connecting carts A and B .
 - b) Determine the magnitude of \vec{F} .
2. Later cart C is held stationary, while carts A and B are released from rest.
 - a) Determine the accelerations of carts A and B .
 - b) Calculate also the tension in the string.

Solution:

Case 1. The force \vec{F} has so big magnitude that the carts A and B remain at the rest with respect to the cart C , *i.e.* they are moving with the same acceleration as the cart C is. Let \vec{G}_1 , \vec{T}_1 and \vec{T}_2 denote forces acting on particular carts as shown in the Figure 2 and let us write the equations of motion for the carts A and B and also for whole mechanical system. Note that certain internal forces (viz. normal reactions) are not shown.

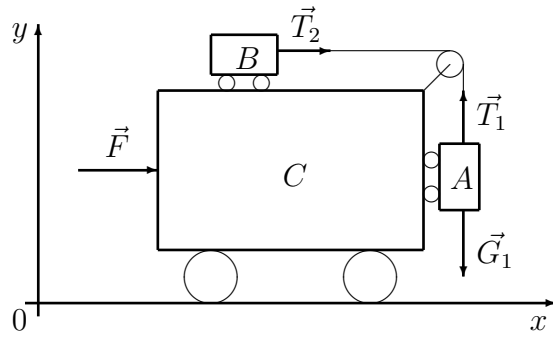

Figure 2:

The cart B is moving in the coordinate system Oxy with an acceleration a_x . The only force acting on the cart B is the force \vec{T}_2 , thus

$$T_2 = m_2 a_x . \quad (1)$$

Since \vec{T}_1 and \vec{T}_2 denote tensions in the same cord, their magnitudes satisfy

$$T_1 = T_2 .$$

The forces \vec{T}_1 and \vec{G}_1 act on the cart A in the direction of the y -axis. Since, according to condition 1, the carts A and B are at rest with respect to the cart C , the acceleration in the direction of the y -axis equals to zero, $a_y = 0$, which yields

$$T_1 - m_1 g = 0 .$$

Consequently

$$T_2 = m_1 g . \quad (2)$$

So the motion of the whole mechanical system is described by the equation

$$F = (m_1 + m_2 + m_3) a_x , \quad (3)$$

because forces between the carts A and C and also between the carts B and C are internal forces with respect to the system of all three bodies. Let us remark here that also the tension \vec{T}_2 is the internal force with respect to the system of all bodies, as can be easily seen from the analysis of forces acting on the pulley. From equations (1) and (2) we obtain

$$a_x = \frac{m_1}{m_2} g.$$

Substituting the last result to (3) we arrive at

$$F = (m_1 + m_2 + m_3) \frac{m_1}{m_2} g.$$

Numerical solution:

$$T_2 = T_1 = 0.3 \cdot 9.81 \text{ N} = 2.94 \text{ N},$$

$$F = 2 \cdot \frac{3}{2} \cdot 9.81 \text{ N} = 29.4 \text{ N}.$$

Case 2. If the cart C is immovable then the cart A moves with an acceleration a_y and the cart B with an acceleration a_x . Since the cord is inextensible (*i.e.* it cannot lengthen), the equality

$$a_x = -a_y = a$$

holds true. Then the equations of motion for the carts A , respectively B , can be written in following form

$$T_1 = G_1 - m_1 a, \tag{4}$$

$$T_2 = m_2 a. \tag{5}$$

The magnitudes of the tensions in the cord again satisfy

$$T_1 = T_2. \tag{6}$$

The equalities (4), (5) and (6) immediately yield

$$(m_1 + m_2) a = m_1 g.$$

Using the last result we can calculate

$$a = a_x = -a_y = \frac{m_1}{m_1 + m_2} g,$$
$$T_2 = T_1 = \frac{m_2 m_1}{m_1 + m_2} g.$$

Numerical results:

$$a = a_x = \frac{3}{5} \cdot 9.81 \text{ m s}^{-2} = 5.89 \text{ m s}^{-2},$$
$$T_1 = T_2 = 1.18 \text{ N}.$$

Problem 2. Water of mass m_2 is contained in a copper calorimeter of mass m_1 . Their common temperature is t_2 . A piece of ice of mass m_3 and temperature $t_3 < 0^\circ\text{C}$ is dropped into the calorimeter.

- a) Determine the temperature and masses of water and ice in the equilibrium state for general values of m_1 , m_2 , m_3 , t_2 and t_3 . Write equilibrium equations for all possible processes which have to be considered.
- b) Find the final temperature and final masses of water and ice for $m_1 = 1.00 \text{ kg}$, $m_2 = 1.00 \text{ kg}$, $m_3 = 2.00 \text{ kg}$, $t_2 = 10^\circ\text{C}$, $t_3 = -20^\circ\text{C}$.

Neglect the energy losses, assume the normal barometric pressure. Specific heat of copper is $c_1 = 0.1 \text{ kcal/kg}\cdot^\circ\text{C}$, specific heat of water $c_2 = 1 \text{ kcal/kg}\cdot^\circ\text{C}$, specific heat of ice $c_3 = 0.492 \text{ kcal/kg}\cdot^\circ\text{C}$, latent heat of fusion of ice $l = 78,7 \text{ kcal/kg}$. Take $1 \text{ cal} = 4.2 \text{ J}$.

Solution:

We use the following notation:

t	temperature of the final equilibrium state,
$t_0 = 0^\circ\text{C}$	the melting point of ice under normal pressure conditions,
M_2	final mass of water,
M_3	final mass of ice,
$m'_2 \leq m_2$	mass of water, which freezes to ice,
$m'_3 \leq m_3$	mass of ice, which melts to water.

- a) Generally, four possible processes and corresponding equilibrium states can occur:

1. $t_0 < t < t_2$, $m'_2 = 0$, $m'_3 = m_3$, $M_2 = m_2 + m_3$, $M_3 = 0$.

Unknown final temperature t can be determined from the equation

$$(m_1c_1 + m_2c_2)(t_2 - t) = m_3c_3(t_0 - t_3) + m_3l + m_3c_2(t - t_0). \quad (7)$$

However, only the solution satisfying the condition $t_0 < t < t_2$ does make physical sense.

2. $t_3 < t < t_0$, $m'_2 = m_2$, $m'_3 = 0$, $M_2 = 0$, $M_3 = m_2 + m_3$.

Unknown final temperature t can be determined from the equation

$$m_1c_1(t_2 - t) + m_2c_2(t_2 - t_0) + m_2l + m_2c_3(t_0 - t) = m_3c_3(t - t_3). \quad (8)$$

However, only the solution satisfying the condition $t_3 < t < t_0$ does make physical sense.

3. $t = t_0$, $m'_2 = 0$, $0 \leq m'_3 \leq m_3$, $M_2 = m_2 + m'_3$, $M_3 = m_3 - m'_3$.

Unknown mass m'_3 can be calculated from the equation

$$(m_1c_1 + m_2c_2)(t_2 - t_0) = m_3c_3(t - t_3) + m'_3l. \quad (9)$$

However, only the solution satisfying the condition $0 \leq m'_3 \leq m_3$ does make physical sense.

4. $t = t_0$, $0 \leq m'_2 \leq m_2$, $m'_3 = 0$, $M_2 = m_2 - m'_2$, $M_3 = m_3 + m'_2$.

Unknown mass m'_2 can be calculated from the equation

$$(m_1c_1 + m_2c_2)(t_2 - t_0) + m'_2l = m_3c_3(t_0 - t_3). \quad (10)$$

However, only the solution satisfying the condition $0 \leq m'_2 \leq m_2$ does make physical sense.

b) Substituting the particular values of m_1 , m_2 , m_3 , t_2 and t_3 to equations (7), (8) and (9) one obtains solutions not making the physical sense (not satisfying the above conditions for t , respectively m'_3). The real physical process under given conditions is given by the equation (10) which yields

$$m'_2 = \frac{m_3c_3(t_0 - t_3) - (m_1c_1 + m_2c_2)(t_2 - t_0)}{l}.$$

Substituting given numerical values one gets $m'_2 = 0.11$ kg. Hence, $t = 0^\circ\text{C}$, $M_2 = m_2 - m'_2 = 0.89$ kg, $M_3 = m_3 + m'_2 = 2.11$ kg.

Problem 3. A small charged ball of mass m and charge q is suspended from the highest point of a ring of radius R by means of an insulating cord of negligible mass. The ring is made of a rigid wire of negligible cross section and lies in a vertical plane. On the ring there is uniformly distributed charge Q of the same sign as q . Determine the length l of the cord so as the equilibrium position of the ball lies on the symmetry axis perpendicular to the plane of the ring.

Find first the general solution and then for particular values $Q = q = 9.0 \cdot 10^{-8}$ C, $R = 5$ cm, $m = 1.0$ g, $\varepsilon_0 = 8.9 \cdot 10^{-12}$ F/m.

Solution:

In equilibrium, the cord is stretched in the direction of resultant force of $\vec{G} = m\vec{g}$ and $\vec{F} = q\vec{E}$, where \vec{E} stands for the electric field strength of the ring on the axis in distance x from the plane of the ring, see Figure 3. Using the triangle similarity, one can write

$$\frac{x}{R} = \frac{Eq}{mg}. \quad (11)$$

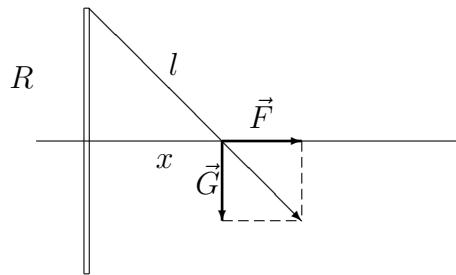

Figure 3:

For the calculation of the electric field strength let us divide the ring to n identical parts, so as every part carries the charge Q/n . The electric field strength magnitude of one part of the ring is given by

$$\Delta E = \frac{Q}{4\pi\varepsilon_0 l^2 n}.$$

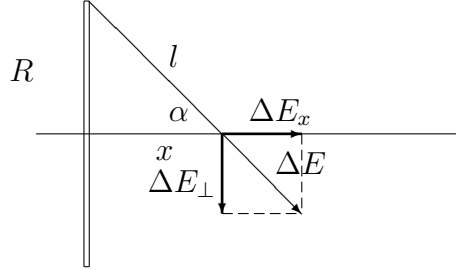

Figure 4:

This electric field strength can be decomposed into the component in the direction of the x -axis and the one perpendicular to the x -axis, see Figure 4. Magnitudes of both components obey

$$\Delta E_x = \Delta E \cos \alpha = \frac{\Delta E x}{l},$$

$$\Delta E_{\perp} = \Delta E \sin \alpha.$$

It follows from the symmetry, that for every part of the ring there exists another one having the component $\Delta \vec{E}_{\perp}$ of the same magnitude, but however oppositely oriented. Hence, components perpendicular to the axis cancel each other and resultant electric field strength has the magnitude

$$E = E_x = n \Delta E_x = \frac{Q x}{4\pi \epsilon_0 l^3}. \quad (12)$$

Substituting (12) into (11) we obtain for the cord length

$$l = \sqrt[3]{\frac{Q q R}{4\pi \epsilon_0 m g}}.$$

Numerically

$$l = \sqrt[3]{\frac{9.0 \cdot 10^{-8} \cdot 9.0 \cdot 10^{-8} \cdot 5.0 \cdot 10^{-2}}{4\pi \cdot 8.9 \cdot 10^{-12} \cdot 10^{-3} \cdot 9.8}} \text{ m} = 7.2 \cdot 10^{-2} \text{ m}.$$

Problem 4. A glass plate is placed above a glass cube of 2 cm edges in such a way that there remains a thin air layer between them, see Figure 5.

Electromagnetic radiation of wavelength between 400 nm and 1150 nm (for which the plate is penetrable) incident perpendicular to the plate from above is reflected from both air surfaces and interferes. In this range only two wavelengths give maximum reinforcements, one of them is $\lambda = 400$ nm. Find the second wavelength. Determine how it is necessary to warm up the cube so as it would touch the plate. The coefficient of linear thermal expansion is $\alpha = 8.0 \cdot 10^{-6} \text{ }^\circ\text{C}^{-1}$, the refractive index of the air $n = 1$. The distance of the bottom of the cube from the plate does not change during warming up.

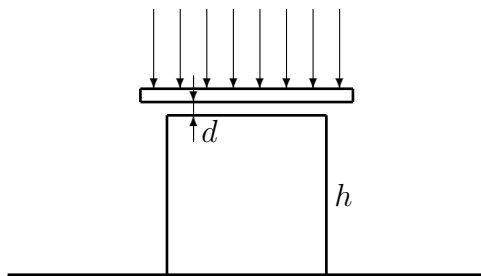

Figure 5:

Solution:

Condition for the maximum reinforcement can be written as

$$2dn - \frac{\lambda_k}{2} = k\lambda_k, \text{ for } k = 0, 1, 2, \dots,$$

i.e.

$$2dn = (2k + 1) \frac{\lambda_k}{2}, \quad (13)$$

with d being thickness of the layer, n the refractive index and k maximum order. Let us denote $\lambda' = 1150$ nm. Since for $\lambda = 400$ nm the condition for maximum is satisfied by the assumption, let us denote $\lambda_p = 400$ nm, where p is an unknown integer identifying the maximum order, for which

$$\lambda_p(2p + 1) = 4dn \quad (14)$$

holds true. The equation (13) yields that for fixed d the wavelength λ_k increases with decreasing maximum order k and vice versa. According to the

assumption,

$$\lambda_{p-1} < \lambda' < \lambda_{p-2},$$

i.e.

$$\frac{4dn}{2(p-1)+1} < \lambda' < \frac{4dn}{2(p-2)+1}.$$

Substituting to the last inequalities for $4dn$ using (14) one gets

$$\frac{\lambda_p(2p+1)}{2(p-1)+1} < \lambda' < \frac{\lambda_p(2p+1)}{2(p-2)+1}.$$

Let us first investigate the first inequality, straightforward calculations give us gradually

$$\lambda_p(2p+1) < \lambda'(2p-1), \quad 2p(\lambda' - \lambda_p) > \lambda' + \lambda_p,$$

i.e.

$$p > \frac{1}{2} \frac{\lambda' + \lambda_p}{\lambda' - \lambda_p} = \frac{1}{2} \frac{1150 + 400}{1150 - 400} = 1. \dots \quad (15)$$

Similarly, from the second inequality we have

$$\lambda_p(2p+1) > \lambda'(2p-3), \quad 2p(\lambda' - \lambda_p) < 3\lambda' + \lambda_p,$$

i.e.

$$p < \frac{1}{2} \frac{3\lambda' + \lambda_p}{\lambda' - \lambda_p} = \frac{1}{2} \frac{3 \cdot 1150 + 400}{1150 - 400} = 2. \dots \quad (16)$$

The only integer p satisfying both (15) and (16) is $p = 2$.

Let us now find the thickness d of the air layer:

$$d = \frac{\lambda_p}{4}(2p+1) = \frac{400}{4}(2 \cdot 2 + 1) \text{ nm} = 500 \text{ nm}.$$

Substituting d to the equation (13) we can calculate λ_{p-1} , *i.e.* λ_1 :

$$\lambda_1 = \frac{4dn}{2(p-1)+1} = \frac{4dn}{2p-1}.$$

Introducing the particular values we obtain

$$\lambda_1 = \frac{4 \cdot 500 \cdot 1}{2 \cdot 2 - 1} \text{ nm} = 666.7 \text{ nm}.$$

Finally, let us determine temperature growth Δt . Generally, $\Delta l = \alpha l \Delta t$ holds true. Denoting the cube edge by h we arrive at $d = \alpha h \Delta t$. Hence

$$\Delta t = \frac{d}{\alpha h} = \frac{5 \cdot 10^{-7}}{8 \cdot 10^{-6} \cdot 2 \cdot 10^{-2}} \text{ }^\circ\text{C} = 3.1 \text{ }^\circ\text{C}.$$

Problems of the IV International Olympiad, Moscow, 1970
The publication is prepared by Prof. S. Kozel & Prof. V.Orlov
(Moscow Institute of Physics and Technology)

The IV International Olympiad in Physics for schoolchildren took place in Moscow (USSR) in July 1970 on the basis of Moscow State University. Teams from 8 countries participated in the competition, namely Bulgaria, Hungary, Poland, Romania, Czechoslovakia, the DDR, the SFR Yugoslavia, the USSR. The problems for the theoretical competition have been prepared by the group from Moscow University staff headed by professor V.Zubov. The problem for the experimental competition has been worked out by B. Zvorikin from the Academy of Pedagogical Sciences.

It is pity that marking schemes were not preserved.

Theoretical Problems

Problem 1.

A long bar with the mass $M = 1$ kg is placed on a smooth horizontal surface of a table where it can move frictionless. A carriage equipped with a motor can slide along the upper horizontal panel of the bar, the mass of the carriage is $m = 0.1$ kg. The friction coefficient of the carriage is $\mu = 0.02$. The motor is winding a thread around a shaft at a constant speed $v_0 = 0.1$ m/s. The other end of the thread is tied up to a rather distant stationary support in one case (Fig.1, a), whereas in the other case it is attached to a picket at the edge of the bar (Fig.1, b). While holding the bar fixed one allows the carriage to start moving at the velocity V_0 then the bar is let loose.

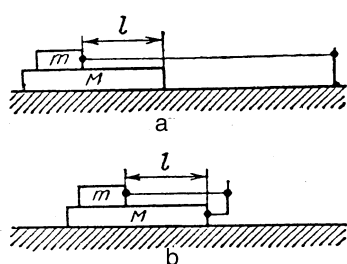

Fig. 1

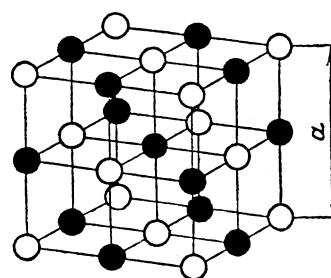

Fig. 2

By the moment the bar is released the front edge of the carriage is at the distance $l = 0.5$ m from the front edge of the bar. For both cases find the laws of movement of both the bar and the carriage and the time during which the carriage will reach the front edge of the bar.

Problem 2.

A unit cell of a crystal of natrium chloride (common salt- NaCl) is a cube with the edge length $a = 5.6 \cdot 10^{-10}$ m (Fig.2). The black circles in the figure stand for the position of natrium atoms whereas the white ones are chlorine atoms. The entire crystal of common salt turns out to be a repetition of such unit cells. The relative atomic mass of natrium is 23 and that of chlorine is 35,5. The density of the common salt $\rho = 2.22 \cdot 10^3$ kg/m³. Find the mass of a hydrogen atom.

Problem 3.

Inside a thin-walled metal sphere with radius $R=20$ cm there is a metal ball with the radius $r = 10$ cm which has a common centre with the sphere. The ball is connected with a very long wire to the Earth via an opening in the sphere (Fig. 3). A charge $Q = 10^{-8}$ C is placed onto the outside sphere. Calculate the potential of this sphere, electrical capacity of the obtained system of conducting bodies and draw out an equivalent electric scheme.

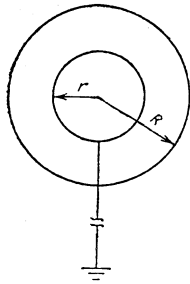

Fig. 3

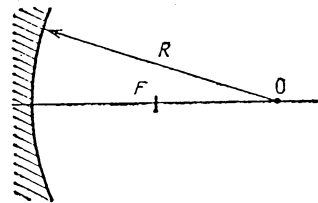

Fig. 4

Problem 4.

A spherical mirror is installed into a telescope. Its lateral diameter is $D=0,5$ m and the radius of the curvature $R=2$ m. In the main focus of the mirror there is an emission receiver in the form of a round disk. The disk is placed perpendicular to the optical axis of the mirror (Fig.7). What should the radius r of the receiver be so that it could receive the entire flux of the emission reflected by the mirror? How would the received flux of the emission decrease if the detector's dimensions decreased by 8 times?

Directions: 1) When calculating small values α ($\alpha \ll 1$) one may perform a substitution

$$\sqrt{1-\alpha} \approx 1 - \frac{\alpha}{2}; \quad 2) \text{ diffraction should not be taken into account.}$$

Experimental Problem

Determine the focal distances of lenses.

List of instruments: three different lenses installed on posts, a screen bearing an image of a geometric figure, some vertical wiring also fixed on the posts and a ruler.

Solutions of the problems of the IV International Olympiad, Moscow, 1970 Theoretical Competition

Problem 1.

a) By the moment of releasing the bar the carriage has a velocity v_0 relative to the table and continues to move at the same velocity.

The bar, influenced by the friction force $F_{\text{fr}} = \mu mg$ from the carriage, gets an acceleration $a = F_{\text{fr}}/M = \mu mg/M$; $a = 0.02$ m/s², while the velocity of the bar changes with time according to the law $v_b = at$.

Since the bar can not move faster than the carriage then at a moment of time $t = t_0$ its sliding will stop, that is $v_b = v_0$. Let us determine this moment of time:

$$t_0 = \frac{v_0}{a} = \frac{v_0 M}{\mu mg} = 5\text{s}$$

By that moment the displacement of the S_b bar and the carriage S_c relative to the table will be equal to

$$S_c = v_0 t_0 = \frac{v_0^2 M}{\mu mg}, \quad S_b = \frac{at_0^2}{2} = \frac{v_0^2 M}{2\mu mg}.$$

The displacement of the carriage relative to the bar is equal to

$$S = S_c - S_b = \frac{v_0^2 M}{2\mu mg} = 0.25\text{m}$$

Since $S < l$, the carriage will not reach the edge of the bar until the bar is stopped by an immovable support. The distance to the support is not indicated in the problem condition so we can not calculate this time. Thus, the carriage is moving evenly at the velocity $v_0 = 0.1$ m/s, whereas the bar is moving for the first 5 sec uniformly accelerated with an acceleration $a = 0.02$ m/s² and then the bar is moving with constant velocity together with the carriage.

b) Since there is no friction between the bar and the table surface the system of the bodies “bar-carriage” is a closed one. For this system one can apply the law of conservation of momentum:

$$mv + Mu = mv_0 \quad (1)$$

where v and u are projections of velocities of the carriage and the bar relative to the table onto the horizontal axis directed along the vector of the velocity v_0 . The velocity of the thread winding v_0 is equal to the velocity of the carriage relative to the bar ($v-u$), that is

$$v_0 = v - u \quad (2)$$

Solving the system of equations (1) and (2) we obtain:

$$u = 0, \quad v = v_0.$$

Thus, being released the bar remains fixed relative to the table, whereas the carriage will be moving with the same velocity v_0 and will reach the edge of the bar within the time t equal to

$$t = l/v_0 = 5 \text{ s.}$$

Problem 2.

Let's calculate the quantities of sodium atoms (n_1) and chlorine atoms (n_2) embedded in a single NaCl unit crystal cell (Fig.2).

One atom of sodium occupies the middle of the cell and it entirely belongs to the cell. 12 atoms of sodium hold the edges of a large cube and they belong to three more cells so as 1/4 part of each belongs to the first cell. Thus we have

$$n_1 = 1 + 12 \cdot 1/4 = 4 \text{ atoms of sodium per unit cell.}$$

In one cell there are 6 atoms of chlorine placed on the side of the cube and 8 placed in the vertices. Each atom from a side belongs to another cell and the atom in the vertex - to seven others. Then for one cell we have

$$n_2 = 6 \cdot 1/2 + 8 \cdot 1/8 = 4 \text{ atoms of chlorine.}$$

Thus 4 atoms of sodium and 4 atoms of chlorine belong to one unit cell of NaCl crystal.

The mass m of such a cell is equal

$$m = 4(m_{\text{rNa}} + m_{\text{rCl}}) \text{ (amu),}$$

where m_{rNa} and m_{rCl} are relative atomic masses of sodium and chlorine. Since the mass of hydrogen atom m_{H} is approximately equal to one atomic mass unit: $m_{\text{H}} = 1.008 \text{ amu} \approx 1 \text{ amu}$ then the mass of an unit cell of NaCl is

$$m = 4(m_{\text{rNa}} + m_{\text{rCl}}) m_{\text{H}}.$$

On the other hand, it is equal $m = \rho a^3$, hence

$$m_{\text{H}} = \frac{\rho a^3}{4(m_{\text{rNa}} + m_{\text{rCl}})} \approx 1.67 \cdot 10^{-27} \text{ kg}.$$

Problem 3.

Having no charge on the ball the sphere has the potential

$$\varphi_{0s} = \frac{1}{4\pi\epsilon_0} \frac{Q}{R} = 450 \text{ V}.$$

When connected with the Earth the ball inside the sphere has the potential equal to zero so there is an electric field between the ball and the sphere. This field moves a certain charge q from the Earth to the ball. Charge Q , uniformly distributed on the sphere, doesn't create any field inside thus the electric field inside the sphere is defined by the ball's charge q . The potential difference between the balls and the sphere is equal

$$\Delta\varphi = \varphi_b - \varphi_s = \frac{1}{4\pi\epsilon_0} \left(\frac{q}{r} - \frac{q}{R} \right), \quad (1)$$

Outside the sphere the field is the same as in the case when all the charges were placed in its center. When the ball was connected with the Earth the potential of the sphere φ_s is equal

$$\varphi_s = \frac{1}{4\pi\epsilon_0} \frac{q+Q}{R}. \quad (2)$$

Then the potential of the ball

$$\varphi_b = \varphi_s + \Delta\varphi = \frac{1}{4\pi\epsilon_0} \left(\frac{q+Q}{R} + \frac{q}{r} - \frac{q}{R} \right) = \frac{1}{4\pi\epsilon_0} \left(\frac{Q}{R} + \frac{q}{r} \right) = 0 \quad (3)$$

Which leads to

$$q = -Q \frac{r}{R}. \quad (4)$$

Substituting (4) into (2) we obtain for potential of the sphere to be found:

$$\varphi_s = \frac{1}{4\pi\epsilon_0} \frac{Q - Q \frac{r}{R}}{R} = \frac{1}{4\pi\epsilon_0} \frac{Q(R-r)}{R^2} = 225\text{V}.$$

The electric capacity of whole system of conductors is

$$C = \frac{Q}{\varphi_s} = \frac{4\pi\epsilon_0 R^2}{R-r} = 4.4 \cdot 10^{-11} \text{F} = 44\text{pF}$$

The equivalent electric scheme consists of two parallel capacitors: 1) a spherical one with charges $+q$ and $-q$ at the plates and 2) a capacitor "sphere – Earth" with charges $+(Q-q)$ and $-(Q-q)$ at the plates (Fig.5).

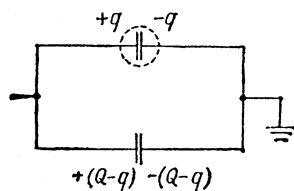

Fig. 5

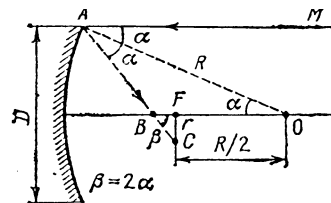

Fig. 6

Problem 4.

As known, rays parallel to the main optical axis of a spherical mirror, passing at little distances from it after having been reflected, join at the main focus of the mirror F which is at the distance $R/2$ from the centre O of the spherical surface. Let us consider now the movement of the ray reflected near the edge of the spherical mirror of large diameter D (Fig. 6). The angle of incidence α of the ray onto the surface is equal to the angle of reflection. That is why the angle OAB within the triangle, formed by the radius OA of the sphere, traced to the incidence point of the ray by the reflected ray AB and an intercept BO of the main optical axis, is equal to α . The angles BOA and MAO are equal, that is the angle BOA is equal to α .

Thus, the triangle AOB is isosceles with its side AB being equal to the side BO . Since the sum of the lengths of its two other sides exceeds the length of its third side, $AB+BO>OA=R$, hence $BO>R/2$. This means that a ray parallel to the main optical axis of the spherical mirror and passing not too close to it, after having been reflected, crosses the main optical axis at the point B lying between the focus F and the mirror. The focal surface is crossed by this ray at the point C which is at a certain distance $CF = r$ from the main focus.

Thus, when reflecting a parallel beam of rays by a spherical mirror finite in size it does not join at the focus of the mirror but forms a beam with radius r on the focal plane.

From ΔBFC we can write :

$$r = BF \operatorname{tg} \beta = BF \operatorname{tg} 2\alpha ,$$

where α is the maximum angle of incidence of the extreme ray onto the mirror, while $\sin \alpha = D/2R$:

$$BF = BO - OF = \frac{R}{2 \cos \alpha} - \frac{R}{2} = \frac{R}{2} \frac{1 - \cos \alpha}{\cos \alpha} .$$

Thus, $r = \frac{R}{2} \frac{1 - \cos \alpha}{\cos \alpha} \frac{\sin 2\alpha}{\cos 2\alpha}$. Let us express the values of $\cos \alpha$, $\sin 2\alpha$, $\cos 2\alpha$ via $\sin \alpha$ taking into account the small value of the angle α :

$$\cos \alpha = \sqrt{1 - \sin^2 \alpha} \approx 1 - \frac{\sin^2 \alpha}{2} ,$$

$$\sin 2\alpha = 2 \sin \alpha \cos \alpha ,$$

$$\cos 2\alpha = \cos^2 \alpha - \sin^2 \alpha = 1 - 2 \sin^2 \alpha .$$

Then

$$r = \frac{R}{2} \frac{\sin^3 \alpha}{1 - 2 \sin^2 \alpha} \approx \frac{R}{2} \sin^3 \alpha \approx \frac{D^3}{16R^2} .$$

Substituting numerical data we will obtain: $r \approx 1.95 \cdot 10^{-3} \text{ m} \approx 2 \text{ mm}$.

From the expression $D = \sqrt[3]{16R^2r}$ one can see that if the radius of the receiver is decreased 8 times the transversal diameter D' of the mirror, from which the light comes to the receiver, will be decreased 2 times and thus the “effective” area of the mirror will be decreased 4 times.

The radiation flux Φ reflected by the mirror and received by the receiver will also be decreased twice since $\Phi \sim S$.

Solution of the Experimental Problem

While looking at objects through lenses it is easy to establish that there were given two converging lenses and a diverging one.

The peculiarity of the given problem is the absence of a white screen on the list of the equipment that is used to observe real images. The competitors were supposed to determine the position of the images by the parallax method observing the images with their eyes.

The focal distance of the converging lens may be determined by the following method.

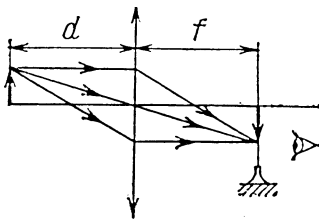

Fig. 7

Using a lens one can obtain a real image of a geometrical figure shown on the screen. The position of the real image is registered by the parallax method: if one places a vertical wire (Fig.7) to the point, in which the image is located, then at small displacements of the eye from the main optical axis of the lens the image of this object and the wire will not diverge.

We obtain the value of focal distance F from the formula of thin lens by the measured distances d and f :

$$\frac{1}{F_{1,2}} = \frac{1}{d} + \frac{1}{f}; \quad F_{1,2} = \frac{df}{d + f}.$$

In this method the best accuracy is achieved in the case of

$$f = d.$$

The competitors were not asked to make a conclusion.

The error of measuring the focal distance for each of the two converging lenses can be determined by multiple repeated measurements. The total number of points was given to those competitors who carried out not less fewer than $n=5$ measurements of the focal distance and estimated the mean value of the focal distance F_{av} :

$$F_{av} = \frac{1}{n} \sum_1^n F_i$$

and the absolute error ΔF

$$\Delta F = \frac{1}{n} \sum_1^n \Delta F_i, \quad \Delta F_i = |F_i - F_{av}|$$

or root mean square error ΔF_{rms}

$$\Delta F_{rms} = \frac{1}{n} \sqrt{\sum (\Delta F_i)^2}.$$

One could calculate the error by graphic method.

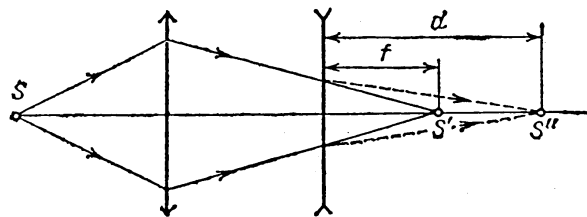

Fig. 8

Determination of the focal distance of the diverging lens can be carried out by the method of compensation. With this goal one has to obtain a real image S' of the object S using a converging lens. The position of the image can be registered using the parallax method.

If one places a diverging lens between the image and the converging lens the image will be displaced. Let us find a new position of the image S'' . Using the reversibility property of the light rays, one can admit that the light rays leave the point S'' . Then point S' is a virtual image of the point S'' , whereas the distances from the optical centre of the concave lens to the points S' and S'' are, respectively, the distances f to the image and d to the object (Fig.8). Using the formula of a thin lens we obtain

$$\frac{1}{F_3} = -\frac{1}{f} + \frac{1}{d}; \quad F_3 = -\frac{fd}{d-f} < 0.$$

Here $F < 0$ is the focal distance of the diverging lens. In this case the error of measuring the focal distance can also be estimated by the method of repeated measurements similar to the case of the

converging lens.

Typical results are:

$$F_1 = (22,0 \pm 0,4)cm, F_2 = (12,3 \pm 0,3)cm, F_3 = (-8,4 \pm 0,4)cm.$$

Acknowledgement

The authors would like to thank Professor Waldemar Gorzkowski (Poland) and Professor Ivo Volf (Czech Republic) for their providing the materials of the IV IPhO in the Polish and Czech languages.

References:

1. O.Kabardin, V.Orlov, International Physics Olympiads for Pupils, Nauka, Moskva 1985
2. W.Gorzkowski, Zadania z fizyki z calego swiata – 20 lat. Miedzyna – rodowych Olimpiad Fizycznych, WNT, Warszawa 1994
3. V.Urumov, Prosvetno Delo, Skopje 1999
4. D.Klivanec, I.Volf, Mezinarodni Fysikalni Olympiady (metodycky material), MaFy, Hradec Kralowe 1993

V International Physics Olympiad, 1971

Sofia, Bulgaria

The problems and the solutions are adapted by

Victor Ivanov

University of Sofia, Faculty of Physics, 5 James Bourchier Blvd., 1164 Sofia, Bulgaria

Reference: O. F. Kabardin, V. A. Orlov, in “International Physics Olympiads for High School Students”, eds. V. G. Razumovski, Moscow, Nauka, 1985. (In Russian).

Theoretical problems

Question 1.

A triangular prism of mass M is placed one side on a frictionless horizontal plane as shown in Fig. 1. The other two sides are inclined with respect to the plane at angles α_1 and α_2 respectively. Two blocks of masses m_1 and m_2 , connected by an inextensible thread, can slide without friction on the surface of the prism. The mass of the pulley, which supports the thread, is negligible.

- Express the acceleration a of the blocks relative to the prism in terms of the acceleration a_0 of the prism.
- Find the acceleration a_0 of the prism in terms of quantities given and the acceleration g due to gravity.
- At what ratio m_1/m_2 the prism will be in equilibrium?

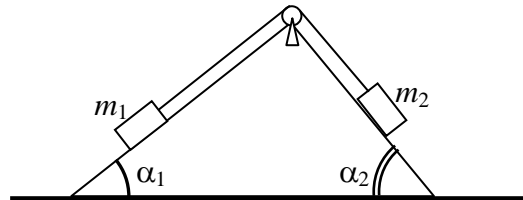

Fig. 1

Question 2.

A vertical glass tube of cross section $S = 1.0 \text{ cm}^2$ contains unknown amount of hydrogen. The upper end of the tube is closed. The other end is opened and is immersed in a pan filled with mercury. The tube and the pan are placed in a sealed chamber containing air at temperature $T_0 = 273 \text{ K}$ and pressure $P_0 = 1.334 \times 10^5 \text{ Pa}$. Under these conditions the height of mercury column in the tube above the mercury level in the pan is $h_0 = 0.70 \text{ m}$.

One of the walls of the chamber is a piston, which expands the air isothermally to a pressure of $P_1 = 8.00 \times 10^4 \text{ Pa}$. As a result the height of the mercury column in the tube decreases to $h_1 = 0.40 \text{ m}$. Then the chamber is heated up at a constant volume to some temperature T_2 until the mercury column rises to $h_2 = 0.50 \text{ m}$. Finally, the air in the chamber is expanded at constant pressure and the mercury level in the tube settles at $h_3 = 0.45 \text{ m}$ above the mercury level in the pan.

Provided that the system is in mechanical and thermal equilibrium during all the processes calculate the mass m of the hydrogen, the intermediate temperature T_2 , and the pressure P in the final state.

The density of mercury at temperature T_0 is $\rho_0 = 1.36 \times 10^4 \text{ kg/m}^3$, the coefficient of expansion for mercury $\beta = 1.84 \times 10^{-4} \text{ K}^{-1}$, and the gas constant $R = 8.314 \text{ J/(mol}\times\text{K)}$. The thermal expansion of the glass tube and the variations of the mercury level in the pan are not considered.

Hint. If ΔT is the interval of temperature variations of the system then $\beta\Delta T = x \ll 1$ In that case you can use the approximation: $\frac{1}{1+x} \approx 1-x$.

Question 3.

Four batteries of EMF $E_1 = 4 \text{ V}$, $E_2 = 8 \text{ V}$, $E_3 = 12 \text{ V}$, and $E_4 = 16 \text{ V}$, four capacitors with the same capacitance $C_1 = C_2 = C_3 = C_4 = 1 \text{ }\mu\text{F}$, and four equivalent resistors are connected in the circuit shown in Fig. 3. The internal resistance of the batteries is negligible.

- Calculate the total energy W accumulated on the capacitors when a steady state of the system is established.
- The points H and B are short connected. Find the charge on the capacitor C_2 in the new steady state.

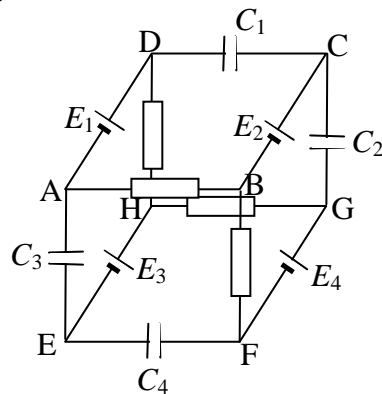

Fig. 3

Question 4.

A spherical aquarium, filled with water, is placed in front of a flat vertical mirror. The radius of the aquarium is R , and the distance between its center and the mirror is $3R$. A small fish, which is initially at the point nearest to the mirror, starts to move with velocity v along the wall. An observer looks at the fish from a very large distance along a horizontal line passing through the center of the aquarium.

What is the relative velocity v_{rel} at which the two images of the fish seen by the observer will move apart? Express your answer in terms of v . Assume that:

- The wall of the aquarium is made of a very thin glass.
- The index of refraction of water is $n = 4/3$.

Experimental Problem

Apparatus: dc source, ammeter, voltmeter, rheostat (coil of high resistance wire with sliding contact), and connecting wires.

Problem: Construct appropriate circuit and establish the dependence of the electric power P dissipated in the rheostat as a function of the current I supplied by the dc source.

1. Make a plot of P versus I .
2. Find the internal resistance of the dc source.
3. Determine the electromotive force E of the source.
4. Make a graph of the electric power P versus resistance R of the rheostat.
5. Make a graph of the total power P_{tot} dissipated in the circuit as a function of R .
6. Make a graph of the efficiency η of the dc source versus R .

Solutions to the problems of the 5-th International Physics Olympiad, 1971, Sofia, Bulgaria

*The problems and the solutions are adapted by
Victor Ivanov*

Sofia State University, Faculty of Physics, 5 James Bourcier Blvd., 1164 Sofia, Bulgaria

Reference: O. F. Kabardin, V. A. Orlov, in “International Physics Olympiads for High School Students”, eds. V. G. Razumovski, Moscow, Nauka, 1985. (In Russian).

Theoretical problems

Question 1.

The blocks slide relative to the prism with accelerations \mathbf{a}_1 and \mathbf{a}_2 , which are parallel to its sides and have the same magnitude a (see Fig. 1.1). The blocks move relative to the earth with accelerations:

$$(1.1) \quad \mathbf{w}_1 = \mathbf{a}_1 + \mathbf{a}_0;$$

$$(1.2) \quad \mathbf{w}_2 = \mathbf{a}_2 + \mathbf{a}_0.$$

Now we project \mathbf{w}_1 and \mathbf{w}_2 along the x - and y -axes:

$$(1.3) \quad w_{1x} = a \cos \alpha_1 - a_0;$$

$$(1.4) \quad w_{1y} = a \sin \alpha_1;$$

$$(1.5) \quad w_{2x} = a \cos \alpha_2 - a_0;$$

$$(1.6) \quad w_{2y} = -a \sin \alpha_2.$$

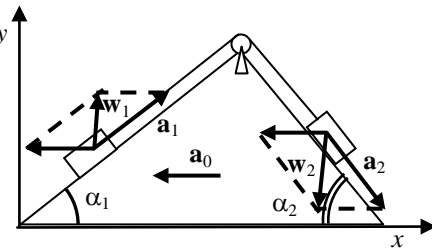

Fig. 1.1

The equations of motion for the blocks and for the prism have the following vector forms (see Fig. 1.2):

$$(1.7) \quad m_1 \mathbf{w}_1 = m_1 \mathbf{g} + \mathbf{R}_1 + \mathbf{T}_1;$$

$$(1.8) \quad m_2 \mathbf{w}_2 = m_2 \mathbf{g} + \mathbf{R}_2 + \mathbf{T}_2;$$

$$(1.9) \quad M \mathbf{a}_0 = M \mathbf{g} - \mathbf{R}_1 - \mathbf{R}_2 + \mathbf{R} - \mathbf{T}_1 - \mathbf{T}_2.$$

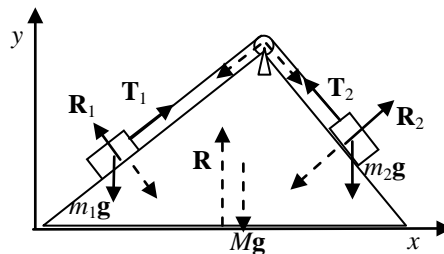

Fig. 1.2

The forces of tension \mathbf{T}_1 and \mathbf{T}_2 at the ends of the thread are of the same magnitude T since the masses of the thread and that of the pulley are negligible. Note that in equation (1.9) we account for the net force $-(\mathbf{T}_1 + \mathbf{T}_2)$, which the bended thread exerts on the

prism through the pulley. The equations of motion result in a system of six scalar equations when projected along x and y :

$$(1.10) \quad m_1 a \cos \alpha_1 - m_1 a_0 = T \cos \alpha_1 - R_1 \sin \alpha_1 ;$$

$$(1.11) \quad m_1 a \sin \alpha_1 = T \sin \alpha_1 + R_1 \cos \alpha_1 - m_1 g ;$$

$$(1.12) \quad m_2 a \cos \alpha_2 - m_2 a_0 = -T \cos \alpha_2 + R_2 \sin \alpha_2 ;$$

$$(1.13) \quad m_2 a \sin \alpha_2 = T \sin \alpha_2 + R_2 \cos \alpha_2 - m_2 g ;$$

$$(1.14) \quad -M a_0 = R_1 \sin \alpha_1 - R_2 \sin \alpha_2 - T \cos \alpha_1 + T \cos \alpha_2 ;$$

$$(1.15) \quad 0 = R - R_1 \cos \alpha_1 - R_2 \cos \alpha_2 - M g .$$

By adding up equations (1.10), (1.12), and (1.14) all forces internal to the system cancel each other. In this way we obtain the required relation between accelerations a and a_0 :

$$(1.16) \quad a = a_0 \frac{M + m_1 + m_2}{m_1 \cos \alpha_1 + m_2 \cos \alpha_2} .$$

The straightforward elimination of the unknown forces gives the final answer for a_0 :

$$(1.17) \quad a_0 = \frac{(m_1 \sin \alpha_1 - m_2 \sin \alpha_2)(m_1 \cos \alpha_1 + m_2 \cos \alpha_2)}{(m_1 + m_2 + M)(m_1 + m_2) - (m_1 \cos \alpha_1 + m_2 \cos \alpha_2)^2} .$$

It follows from equation (1.17) that the prism will be in equilibrium ($a_0 = 0$) if:

$$(1.18) \quad \frac{m_1}{m_2} = \frac{\sin \alpha_2}{\sin \alpha_1} .$$

Question 2.

We will denote by H ($H = \text{const}$) the height of the tube above the mercury level in the pan, and the height of the mercury column in the tube by h_i . Under conditions of mechanical equilibrium the hydrogen pressure in the tube is:

$$(2.1) \quad P_{H_2} = P_{air} - \rho g h_i ,$$

where ρ is the density of mercury at temperature t_i :

$$(2.2) \quad \rho = \rho_0 (1 - \beta t)$$

The index i enumerates different stages undergone by the system, ρ_0 is the density of mercury at $t_0 = 0$ °C, or $T_0 = 273$ K, and β its coefficient of expansion. The volume of the hydrogen is given by:

$$(2.3) \quad V_i = S(H - h_i).$$

Now we can write down the equations of state for hydrogen at points 0, 1, 2, and 3 of the PV diagram (see Fig. 2):

$$(2.4) \quad (P_0 - \rho_0 g h_0) S(H - h_0) = \frac{m}{M} R T_0 ;$$

$$(2.5) \quad (P_1 - \rho_0 g h_1) S(H - h_1) = \frac{m}{M} R T_0 ;$$

$$(2.6) \quad (P_2 - \rho_1 g h_2) S(H - h_2) = \frac{m}{M} R T_2 ,$$

where $P_2 = \frac{P_1 T_2}{T_0}$, $\rho_1 = \frac{\rho_0}{1 + \beta(T_2 - T_0)} \approx \rho_0 [1 - \beta(T_2 - T_0)]$ since the process 1–3 is

isochoric, and:

$$(2.7) \quad (P_2 - \rho_2 g h_3) S (H - h_3) = \frac{m}{M} R T_3$$

where $\rho_2 \approx \rho_0 [1 - \beta(T_3 - T_0)]$, $T_3 = T_2 \frac{V_3}{V_2} = T_2 \frac{H - h_3}{H - h_2}$ for the isobaric process 2–3.

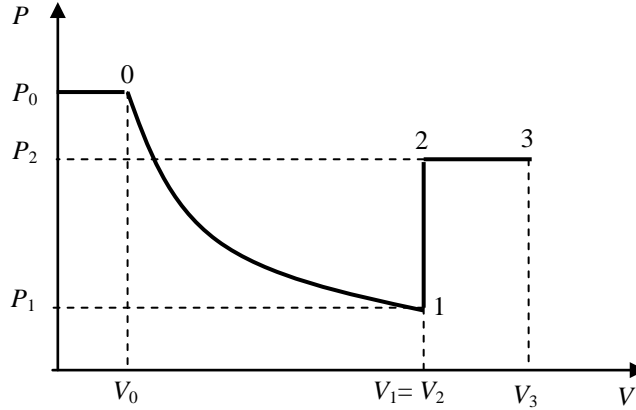

Fig. 2

After a good deal of algebra the above system of equations can be solved for the unknown quantities, an exercise, which is left to the reader. The numerical answers, however, will be given for reference:

$$\begin{aligned} H &\approx 1.3 \text{ m;} \\ m &\approx 2.11 \times 10^{-6} \text{ kg;} \\ T_2 &\approx 364 \text{ K;} \\ P_2 &\approx 1.067 \times 10^5 \text{ Pa;} \\ T_3 &\approx 546 \text{ K;} \\ P_2 &\approx 4.8 \times 10^4 \text{ Pa.} \end{aligned}$$

Question 3.

A circuit equivalent to the given one is shown in Fig. 3. In a steady state (the capacitors are completely charged already) the same current I flows through all the resistors in the closed circuit A B F G H D A. From the Kirchhoff's second rule we obtain:

$$(3.1) \quad I = \frac{E_4 - E_1}{4R}.$$

Next we apply this rule for the circuit ABCDA:

$$(3.2) \quad V_1 + IR = E_2 - E_1,$$

where V_1 is the potential difference across the capacitor C_1 . By using the expression (3.1) for I , and the equation (3.2) we obtain:

$$(3.3) \quad V_1 = E_2 - E_1 - \frac{E_4 - E_1}{4} = 1 \text{ V.}$$

Similarly, we obtain the potential differences V_2 and V_4 across the capacitors C_2 and C_4 by considering circuits BFGCB and FGHEF:

$$(3.4) \quad V_2 = E_4 - E_2 - \frac{E_4 - E_1}{4} = 5 \text{ V,}$$

$$(3.5) \quad V_4 = E_4 - E_3 - \frac{E_4 - E_1}{4} = 1 \text{ V.}$$

Finally, the voltage V_3 across C_3 is found by applying the Kirchoff's rule for the outermost circuit EHDAAH:

$$(3.6) \quad V_3 = E_3 - E_1 - \frac{E_4 - E_1}{4} = 5 \text{ V.}$$

The total energy of the capacitors is expressed by the formula:

$$(3.7) \quad W = \frac{C}{2} (V_1^2 + V_2^2 + V_3^2 + V_4^2) = 26 \mu\text{J.}$$

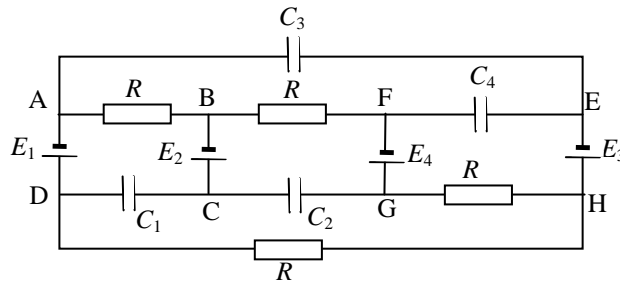

Fig. 3

When points B and H are short connected the same electric current I' flows through the resistors in the BFGH circuit. It can be calculated, again by means of the Kirchoff's rule, that:

$$(3.8) \quad I' = \frac{E_4}{2R}.$$

The new steady-state voltage on C_2 is found by considering the BFGCB circuit:

$$(3.9) \quad V_2' + I'R = E_4 - E_2$$

or finally:

$$(3.10) \quad V_2' = \frac{E_4}{2} - E_2 = 0 \text{ V.}$$

Therefore the charge q_2' on C_2 in the new steady state is zero.

Question 4.

In a small time interval Δt the fish moves upward, from point A to point B, at a small distance $d = v\Delta t$. Since the glass wall is very thin we can assume that the rays leaving the aquarium refract as if there was water – air interface. The divergent rays undergoing one single refraction, as show in Fig. 4.1, form the first, virtual, image of the fish. The corresponding vertical displacement A_1B_1 of that image is equal to the distance d_1 between the optical axis a and the ray b_1 , which leaves the aquarium parallel to a . Since distances d and d_1 are small compared to R we can use the small-angle approximation: $\sin\alpha \approx \tan\alpha \approx \alpha$ (rad). Thus we obtain:

$$(4.1) \quad d_1 \approx R\alpha;$$

$$(4.2) \quad d \approx R\gamma;$$

$$(4.3) \quad \alpha + \gamma = 2\beta;$$

$$(4.4) \quad \alpha \approx n\beta.$$

From equations (4.1) - (4.4) we find the vertical displacement of the first image in terms of d :

$$(4.5) \quad d_1 = \frac{n}{2-n} d,$$

and respectively its velocity v_1 in terms of v :

$$(4.6) \quad v_1 = \frac{n}{2-n} v = 2v.$$

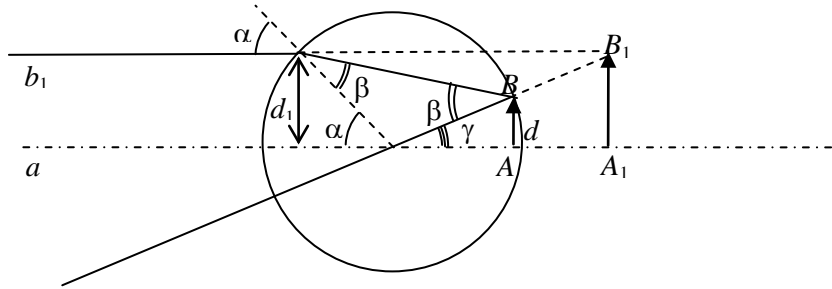

Fig. 4.1

The rays, which are first reflected by the mirror, and then are refracted twice at the walls of the aquarium form the second, real image (see Fig. 4.2). It can be considered as originating from the mirror image of the fish, which move along the line $A'B'$ at exactly the same distance d as the fish do.

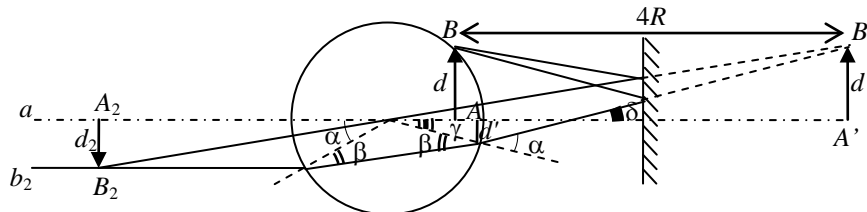

Fig. 4.2

The vertical displacement A_2B_2 of the second image is equal to the distance d_2 between the optical axis a and the ray b_2 , which is parallel to a . Again, using the small-angle approximation we have:

$$(4.7) \quad d' \approx 4R\delta - d,$$

$$(4.8) \quad d_2 \approx R\alpha$$

Following the derivation of equation (4.5) we obtain:

$$(4.9) \quad d_2 = \frac{n}{2-n} d'.$$

Now using the exact geometric relations:

$$(4.10) \quad \delta = 2\alpha - 2\beta$$

and the Snell's law (4.4) in a small-angle limit, we finally express d_2 in terms of d :

$$(4.11) \quad d_2 = \frac{n}{9n-10}d,$$

and the velocity v_2 of the second image in terms of v :

$$(4.12) \quad v_2 = \frac{n}{9n-10}v = \frac{2}{3}v.$$

The relative velocity of the two images is:

$$(4.13) \quad \mathbf{v}_{\text{rel}} = \mathbf{v}_1 - \mathbf{v}_2$$

in a vector form. Since vectors \mathbf{v}_1 and \mathbf{v}_2 are oppositely directed (one of the images moves upward, the other, downward) the magnitude of the relative velocity is:

$$(4.14) \quad v_{\text{rel}} = v_1 + v_2 = \frac{8}{3}v.$$

Experimental problem

The circuit is given in the figure below:

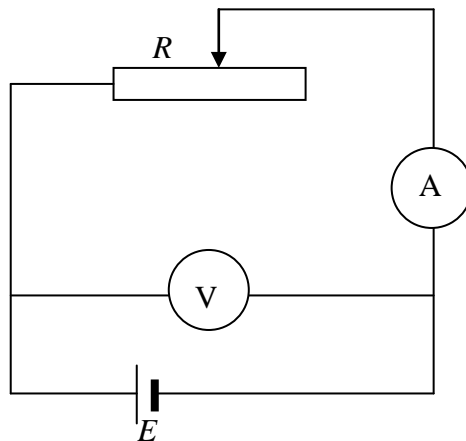

Sliding the contact along the rheostat sets the current I supplied by the source. For each value of I the voltage U across the source terminals is recorded by the voltmeter. The power dissipated in the rheostat is:

$$P = UI$$

provided that the heat losses in the internal resistance of the ammeter are negligible.

1. A typical P - I curve is shown below:

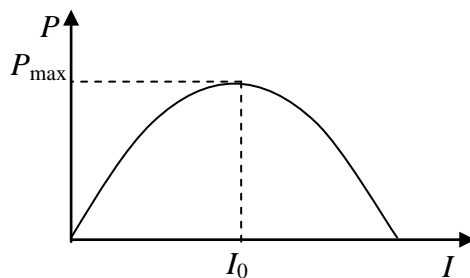

If the current varies in a sufficiently large interval a maximum power P_{\max} can be detected at a certain value, I_0 , of I . Theoretically, the $P(I)$ dependence is given by:

$$(5.1) \quad P = EI - I^2 r,$$

where E and r are the EMF and the internal resistance of the dc source respectively. The maxim value of P therefore is:

$$(5.2) \quad P_{\max} = \frac{E^2}{4r},$$

and corresponds to a current:

$$(5.3) \quad I_0 = \frac{E}{2r}.$$

2. The internal resistance is determined trough (5.2) and (5.3) by recording P_{\max} and I_0 from the experimental plot:

$$r = \frac{P_{\max}}{I_0^2}.$$

3. Similarly, EMF is calculated as:

$$E = \frac{2P_{\max}}{I_0}.$$

4. The current depends on the resistance of the rheostat as:

$$I = \frac{E}{R + r}.$$

Therefore a value of R can be calculated for each value of I :

$$(5.4) \quad R = \frac{E}{I} - r.$$

The power dissipated in the rheostat is given in terms of R respectively by:

$$(5.5) \quad P = \frac{E^2 R}{(R + r)^2}.$$

The P - R plot is given below:

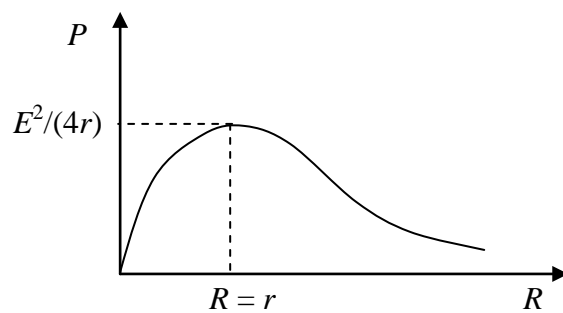

Its maximum is obtained at $R = r$.

5. The total power supplied by the dc source is:

$$(5.6) \quad P_{\text{tot}} = \frac{E^2}{R + r}.$$

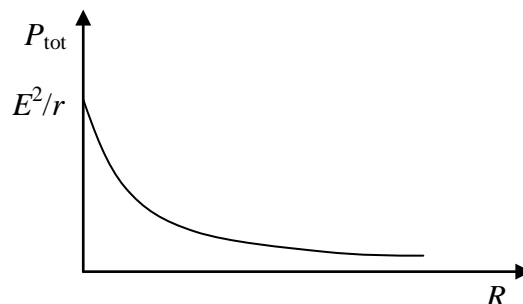

6. The efficiency respectively is:

$$(5.7) \quad \eta = \frac{P}{P_{tot}} = \frac{R}{R+r}.$$

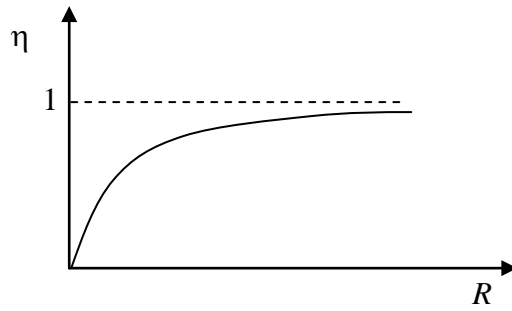

Problems of the 6th International Physics Olympiad (Bucharest, 1972)

Romulus Pop
Civil Engineering University, Physics Department¹
Bucharest, Romania

The sixth IPhO was held in Bucharest and the participants were: Bulgaria, Czechoslovakia, Cuba, France, German Democratic Republic, Hungary, Poland, Romania, and Soviet Union. It was an important event because it was the first time when a non-European country and a western country participated (Cuba), and Sweden sent one observer.

The International Board selected four theoretical problems and an experimental problem. Each theoretical problem was scored from 0 to 10 and the maximum score for the experimental problem was 20. The highest score corresponding to actual marking system was 47,5 points. Each team consisted in six students. Four students obtained the first prize, seven students obtained the second prize, ten students obtained the third prize, thirteen students had got honorable mentions, and two special prizes were awarded too.

The article contains the competition problems given at the 6th International Physics Olympiad (Bucharest, 1972) and their solutions. The problems were translated from the book published in Romania concerning the first nine International Physics Olympiads², because I couldn't find the original English version.

Theoretical problems

Problem 1 (Mechanics)

Three cylinders with the same mass, the same length and the same external radius are initially resting on an inclined plane. The coefficient of sliding friction on the inclined plane, μ , is known and has the same value for all the cylinders. The first cylinder is empty (tube), the second is homogeneous filled, and the third has a cavity exactly like the first, but closed with two negligible mass lids and filled with a liquid with the same density like the cylinder's walls. The friction between the liquid and the cylinder wall is considered negligible. The density of the material of the first cylinder is n times greater than that of the second or of the third cylinder.

Determine:

- The linear acceleration of the cylinders in the non-sliding case. Compare all the accelerations.
- Condition for angle α of the inclined plane so that no cylinders is sliding.
- The reciprocal ratios of the angular accelerations in the case of roll over with sliding of all the three cylinders. Make a comparison between these accelerations.
- The interaction force between the liquid and the walls of the cylinder in the case of sliding of this cylinder, knowing that the liquid mass is m_l .

¹ E-mail: popr@tvet.ro

² Marius Gall and Anatolie Hristev, Probleme date la Olimpiadele de Fizica, Editura Didactica si Pedagogica – Bucuresti, 1978

Solution Problem 1

The inertia moments of the three cylinders are:

$$I_1 = \frac{1}{2} \rho_1 \pi (R^4 - r^4) h, \quad I_2 = \frac{1}{2} \rho_2 \pi R^4 h = \frac{1}{2} m R^2, \quad I_3 = \frac{1}{2} \rho_2 \pi (R^4 - r^4) h, \quad (1)$$

Because the three cylinders have the same mass :

$$m = \rho_1 \pi (R^2 - r^2) h = \rho_2 \pi R^2 h \quad (2)$$

it results:

$$r^2 = R^2 \left(1 - \frac{\rho_2}{\rho_1} \right) = R^2 \left(1 - \frac{1}{n} \right), \quad n = \frac{\rho_1}{\rho_2} \quad (3)$$

The inertia moments can be written:

$$I_1 = I_2 \left(2 - \frac{1}{n} \right), \quad I_3 = I_2 \left(2 - \frac{1}{n} \right) \cdot \frac{1}{n} = \frac{I_1}{n} \quad (4)$$

In the expression of the inertia momentum I_3 the sum of the two factors is constant:

$$\left(2 - \frac{1}{n} \right) + \frac{1}{n} = 2$$

independent of n, so that their products are maximum when these factors are equal:

$2 - \frac{1}{n} = \frac{1}{n}$; it results $n = 1$, and the products $\left(2 - \frac{1}{n} \right) \cdot \frac{1}{n} = 1$. In fact $n > 1$, so that the products is less than 1. It results:

$$I_1 > I_2 > I_3 \quad (5)$$

For a cylinder rolling over freely on the inclined plane (fig. 1.1) we can write the equations:

$$mg \sin \alpha - F_f = ma \quad (6)$$

$$N - mg \cos \alpha = 0$$

$$F_f R = I \varepsilon \quad (7)$$

where ε is the angular acceleration. If the cylinder doesn't slide we have the condition:

$$a = \varepsilon R \quad (8)$$

Solving the equation system (6-8) we find:

$$a = \frac{g \sin \alpha}{1 + \frac{I}{mR^2}}, \quad F_f = \frac{mg \sin \alpha}{1 + \frac{mR^2}{I}} \quad (9)$$

The condition of non-sliding is:

$$F_f < \mu N = \mu mg \sin \alpha$$

$$\operatorname{tg} \alpha < \mu \left(1 + \frac{mR^2}{I_1} \right) \quad (10)$$

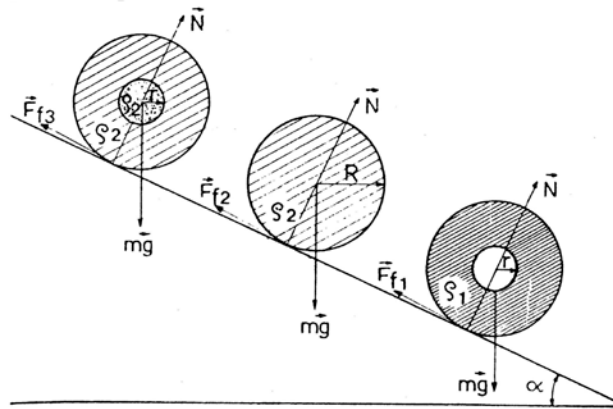

Fig. 1.1

In the case of the cylinders from this problem, the condition necessary so that none of them slides is obtained for maximum I:

$$\operatorname{tg} \alpha < \mu \left(1 + \frac{mR^2}{I_1} \right) = \mu \frac{4n-1}{2n-1} \quad (11)$$

The accelerations of the cylinders are:

$$a_1 = \frac{2g \sin \alpha}{3 + \left(1 - \frac{1}{n}\right)}, \quad a_2 = \frac{2g \sin \alpha}{3}, \quad a_3 = \frac{2g \sin \alpha}{3 - \left(1 - \frac{1}{n}\right)^2}. \quad (12)$$

The relation between accelerations:

$$a_1 < a_2 < a_3 \quad (13)$$

In the case than all the three cylinders slide:

$$F_f = \mu N = \mu mg \cos \alpha \quad (14)$$

and from (7) results:

$$\varepsilon = \frac{R}{I} \mu mg \cos \alpha \quad (15)$$

for the cylinders of the problem:

$$\varepsilon_1 : \varepsilon_2 : \varepsilon_3 = \frac{1}{I_1} : \frac{1}{I_2} : \frac{1}{I_3} = 1 : \left(1 - \frac{1}{n}\right) : n$$

$$\varepsilon_1 < \varepsilon_2 < \varepsilon_3 \quad (16)$$

In the case that one of the cylinders is sliding:

$$mg \sin \alpha - F_f = ma, \quad F_f = \mu mg \cos \alpha, \quad (17)$$

$$a = g(\sin \alpha - \mu \cos \alpha) \quad (18)$$

Let \vec{F} be the total force acting on the liquid mass m_l inside the cylinder (fig.1.2), we can write:

$$F_x + m_l g \sin \alpha = m_l a = m_l g(\sin \alpha - \mu \cos \alpha), \quad F_y - m_l g \cos \alpha = 0 \quad (19)$$

$$F = \sqrt{F_x^2 + F_y^2} = m_l g \cos \alpha \cdot \sqrt{1 + \mu^2} = m_l g \frac{\cos \alpha}{\cos \phi} \quad (20)$$

where ϕ is the friction angle ($\tan \phi = \mu$).

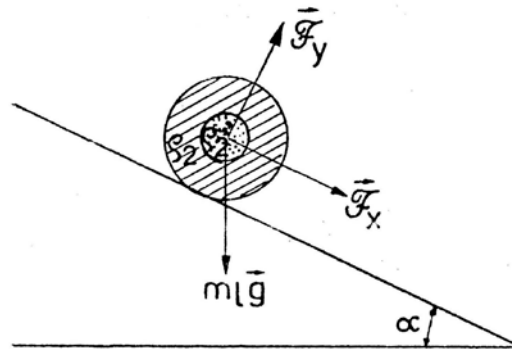

Fig. 1.2

Problem 2 (Molecular Physics)

Two cylinders A and B, with equal diameters have inside two pistons with negligible mass connected by a rigid rod. The pistons can move freely. The rod is a short tube with a valve. The valve is initially closed (fig. 2.1).

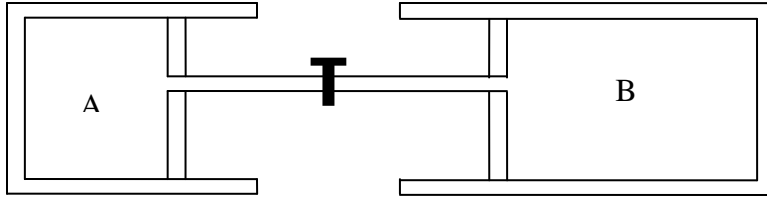

Fig. 2.1

The cylinder A and his piston is adiabatically insulated and the cylinder B is in thermal contact with a thermostat which has the temperature $\theta = 27^\circ\text{C}$.

Initially the piston of the cylinder A is fixed and inside there is a mass $m = 32\text{ kg}$ of argon at a pressure higher than the atmospheric pressure. Inside the cylinder B there is a mass of oxygen at the normal atmospheric pressure.

Liberating the piston of the cylinder A, it moves slowly enough (quasi-static) and at equilibrium the volume of the gas is eight times higher, and in the cylinder B de oxygen's density increased two times. Knowing that the thermostat received the heat $Q' = 747,9 \cdot 10^4\text{ J}$, determine:

- Establish on the base of the kinetic theory of the gases, studying the elastic collisions of the molecules with the piston, that the thermal equation of the process taking place in the cylinder A is $TV^{2/3} = \text{constant}$.
- Calculate the parameters p , V , and T of argon in the initial and final states.
- Opening the valve which separates the two cylinders, calculate the final pressure of the mixture of the gases.

The kilo-molar mass of argon is $\mu = 40\text{ kg/kmol}$.

Solution Problem 2

a) We consider argon an ideal mono-atomic gas and the collisions of the atoms with the piston perfect elastic. In such a collision with a fix wall the speed \vec{v} of the particle changes only the direction so that the speed \vec{v} and the speed \vec{v}' after collision there are in the same plane with the normal and the incident and reflection angle are equal.

$$v'_n = -v_n, v'_t = v_t \quad (1)$$

In the problem the wall moves with the speed \vec{u} perpendicular on the wall. The relative speed of the particle with respect the wall is $\vec{v} - \vec{u}$. Choosing the Oz axis perpendicular on the wall in the sense of \vec{u} , the conditions of the elastic collision give:

$$\begin{aligned} (\vec{v} - \vec{u})_z &= -(\vec{v}' - \vec{u})_z, (\vec{v} - \vec{u})_{x,y} = (\vec{v}' - \vec{u})_{x,y}; \\ v_z - u &= -(v'_z - u), v'_z = 2u - v_z, v'_{x,y} = v_{x,y} \end{aligned} \quad (2)$$

The increase of the kinetic energy of the particle with mass m_o after collision is:

$$\frac{1}{2}m_o v'^2 - \frac{1}{2}m_o v^2 = \frac{1}{2}m_o (v_z'^2 - v_z^2) = 2m_o u(u - v_z) \cong -2m_o u v_z \quad (3)$$

because u is much smaller than v_z .

If n_k is the number of molecules from unit volume with the speed component v_{zk} , then the number of molecules with this component which collide in the time dt the area dS of the piston is:

$$\frac{1}{2} n_k v_{zk} dt dS \quad (4)$$

These molecules will have a change of the kinetic energy:

$$\frac{1}{2} n_k v_{zk} dt dS (-2m_o u v_{zk}) = -m_o n_k v_{zk}^2 dV \quad (5)$$

where $dV = u dt dS$ is the increase of the volume of gas.

The change of the kinetic energy of the gas corresponding to the increase of volume dV is:

$$dE_c = -m_o dV \sum_k n_k v_{zk}^2 = -\frac{1}{3} n m_o \bar{v}^2 dV \quad (6)$$

and:

$$dU = -\frac{2}{3} N \frac{m_o \bar{v}^2}{2} \cdot \frac{dV}{V} = -\frac{2}{3} U \frac{dV}{V} \quad (7)$$

Integrating equation (7) results:

$$UV^{2/3} = const. \quad (8)$$

The internal energy of the ideal mono-atomic gas is proportional with the absolute temperature T and the equation (8) can be written:

$$TV^{2/3} = const. \quad (9)$$

b) The oxygen is in contact with a thermostat and will suffer an isothermal process. The internal energy will be modified only by the adiabatic process suffered by argon gas:

$$\Delta U = \nu C_v \Delta T = m c_v \Delta T \quad (10)$$

where ν is the number of kilomoles. For argon $C_v = \frac{3}{2} R$.

For the entire system $L=0$ and $\Delta U = Q$.

We will use indices 1, respectively 2, for the measures corresponding to argon from cylinder A, respectively oxygen from the cylinder B:

$$\Delta U = \frac{m_1}{\mu_1} \cdot \frac{3}{2} \cdot R (T_1' - T_1) = Q = \frac{m_1}{\mu_1} \cdot \frac{3}{2} R T_1 \left[\left(\frac{V_1}{V_1'} \right)^{2/3} - 1 \right] \quad (11)$$

From equation (11) results:

$$T_1 = \frac{2}{3} \cdot \frac{\mu_1}{m_1} \cdot \frac{Q}{R} \cdot \frac{1}{\left(\frac{V_1}{V_1'} \right)^{2/3} - 1} = 1000K \quad (12)$$

$$T_1' = \frac{T_1}{4} = 250K \quad (13)$$

For the isothermal process suffered by oxygen:

$$\frac{\rho_2}{\rho_2'} = \frac{p_2}{p_2'} \quad (14)$$

$$p_2' = 2,00 atm = 2,026 \cdot 10^5 N/m^2$$

From the equilibrium condition:

$$p_1' = p_2' = 2 \text{ atm} \quad (15)$$

For argon:

$$p_1 = p_1' \cdot \frac{V_1'}{V_1} \cdot \frac{T_1}{T_1'} = 64 \text{ atm} = 64,9 \cdot 10^5 \text{ N/m}^2 \quad (16)$$

$$V_1 = \frac{m_1}{\mu_1} \cdot \frac{RT_1}{p_1} = 1,02 \text{ m}^3, V_1' = 8V_1 = 8,16 \text{ m}^3 \quad (17)$$

c) When the valve is opened the gases intermix and at thermal equilibrium the final pressure will be p' and the temperature T . The total number of kilomoles is constant:

$$v_1 + v_2 = v', \frac{p_1' V_1'}{RT_1'} + \frac{p_2' V_2'}{RT} = \frac{p(V_1' + V_2')}{RT} \quad (18)$$

$$p_1' + p_2' = 2 \text{ atm}, T_2 = T_2' = T = 300 \text{ K}$$

The total volume of the system is constant:

$$V_1 + V_2 = V_1' + V_2', \quad \frac{V_2'}{V_2} = \frac{\rho_2'}{\rho_2}, \quad V_2' = \frac{V_2}{2} = 7,14 \text{ m}^3 \quad (19)$$

From equation (18) results the final pressure:

$$p = p_1' \cdot \frac{1}{V_1' + V_2'} \cdot \left(V_1' \cdot \frac{T}{T_1'} + V_2' \right) = 2,2 \text{ atm} = 2,23 \cdot 10^5 \text{ N/m}^2 \quad (20)$$

Problem 3 (Electricity)

A plane capacitor with rectangular plates is fixed in a vertical position having the lower part in contact with a dielectric liquid (fig. 3.1)

Determine the height, h , of the liquid between the plates and explain the phenomenon.

The capillarity effects are neglected.

It is supposed that the distance between the plates is much smaller than the linear dimensions of the plates.

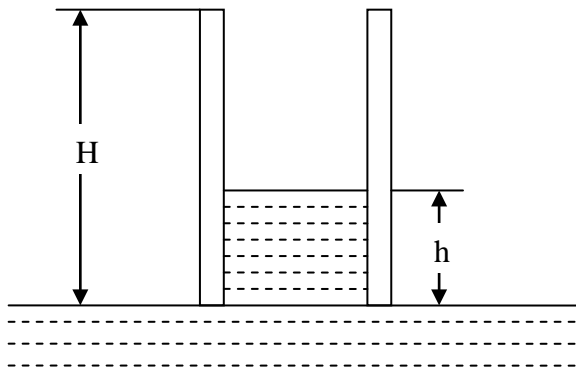

Fig. 3.1

It is known: the initial intensity of the electric field of the charged capacitor, E , the density ρ , the relative electric permittivity ϵ_r of the liquid, and the height H of the plates of the capacitor.

Discussion.

Solution Problem 3

The initial energy on the capacitor is:

$$W_o = \frac{1}{2} \cdot C_o U_o^2 = \frac{1}{2} \cdot \frac{Q_o^2}{C_o}, \text{ where } C_o = \frac{\epsilon_o H l}{d} \quad (1)$$

H is the height of the plates, l is the width of the capacitor's plates, and d is the distance between the plates.

When the plates contact the liquid's surface on the dielectric liquid is exerted a vertical force. The total electric charge remains constant and there is no energy transferred to the system from outside. The increase of the gravitational energy is compensated by the decrease of the electrical energy on the capacitor:

$$W_o = W_1 + W_2 \quad (2)$$

$$W_1 = \frac{1}{2} \cdot \frac{Q_o^2}{C}, \quad W_2 = \frac{1}{2} \rho g h^2 l d \quad (3)$$

$$C = C_1 + C_2 = \frac{\epsilon_o \epsilon_r h l}{d} + \frac{\epsilon_o (H - h) l}{d} \quad (4)$$

Introducing (3) and (4) in equation (2) it results:

$$(\epsilon_r - 1)h^2 + Hh - \frac{E_o^2 \epsilon_o H (\epsilon_r - 1)}{\rho g} = 0$$

The solution is:

$$h_{1,2} = \frac{H}{2(\epsilon_r - 1)} \cdot \left[-1 \pm \sqrt{1 \pm \frac{4E_o^2 \epsilon_o (\epsilon_r - 1)^2}{\rho g H}} \right] \quad (8)$$

Discussion: Only the positive solution has sense. Taking in account that H is much more greater than h we obtain the final result:

$$h \approx \frac{\epsilon_o (\epsilon_r - 1)}{\rho g} \cdot E_o^2$$

Problem 4 (Optics)

A thin lens plane-convex with the diameter 2r, the curvature radius R and the refractive index n_o is positioned so that on its left side is air ($n_1 = 1$), and on its right side there is a transparent medium with the refractive index $n_2 \neq 1$. The convex face of the lens is directed towards air. In the air, at the distance s_1 from the lens, measured on the principal optic ax, there is a punctual source of monochromatic light.

a) Demonstrate, using Gauss approximation, that between the position of the image, given by the distance s_2 from the lens, and the position of the light source, exists the relation:

$$\frac{f_1}{s_1} + \frac{f_2}{s_2} = 1$$

where f_1 and f_2 are the focal distances of the lens, in air, respectively in the medium with the refractive index n_2 .

Observation: All the refractive indexes are absolute indexes.

b) The lens is cut perpendicular on its plane face in two equal parts. These parts are moved away at a distance $\delta \ll r$ (Billet lens). On the symmetry axis of the system obtained is led a punctual source of light at the distance s_1 ($s_1 > f_1$) (fig. 4.1). On the right side of the lens there is a screen E at the distance d . The screen is parallel with the plane face of the lens. On this screen there are N interference fringes, if on the right side of the lens is air.

Determine N function of the wave length.

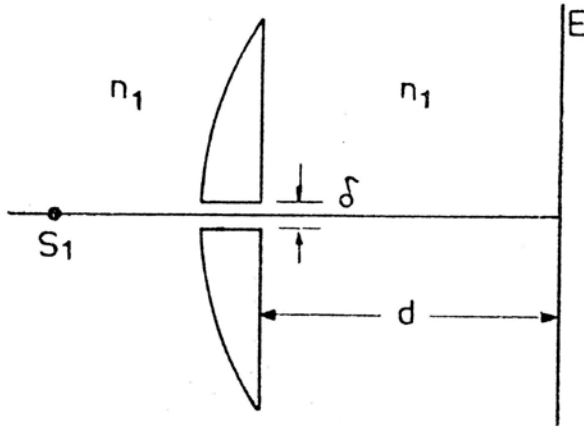

Fig. 4.1

Solution problem 4

a) From the Fermat principle it results that the time the light arrives from P_1 to P_2 is not dependent of the way, in gauss approximation (P_1 and P_2 are conjugated points).

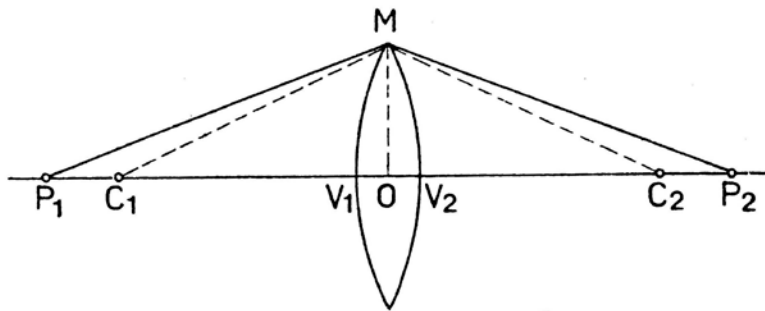

Fig. 4.2

T_1 is the time the light roams the optical way $P_1V_1OV_2P_2$ (fig. 4.2):

$$T_1 = \frac{P_1M}{v_1} + \frac{P_2M}{v_2}, \text{ where } P_1M = \sqrt{P_1O^2 + MO^2} \approx P_1O + \frac{h^2}{2P_1O}, \text{ and } P_2M \approx P_2O + \frac{h^2}{2P_2O}$$

because $h = OM$ is much more smaller than P_1O or P_2O .

$$T_1 = \frac{P_1O}{v_1} + \frac{P_2O}{v_2} + \frac{h^2}{2} \cdot \left(\frac{1}{v_1 P_1O} + \frac{1}{v_2 P_2O} \right); T_2 = \frac{P_1V_1}{v_1} + \frac{V_2P_2}{v_2} + \frac{V_1V_2}{v} \quad (1)$$

$$V_1 V_2 \cong \frac{h^2}{2} \cdot \left(\frac{1}{R_1} + \frac{1}{R_2} \right) \quad (2)$$

From condition $T_1 = T_2$, it results:

$$\frac{1}{v_1 P_1 O} + \frac{1}{v_2 P_2 O} = \frac{1}{v} \left(\frac{1}{R_1} + \frac{1}{R_2} \right) - \frac{1}{v_1 R_1} - \frac{1}{v_2 R_2} \quad (3)$$

Taking in account the relation $v = \frac{c}{n}$, and using $P_1 O = s_1$, $OP_2 = s_2$, the relation (3) can be written:

$$\frac{n_1}{s_1} + \frac{n_2}{s_2} = n_o \left(\frac{1}{R_1} + \frac{1}{R_2} \right) - \frac{1}{v_1 R_1} - \frac{1}{v_2 R_2} \quad (4)$$

If the point P_1 is at infinite, s_2 becomes the focal distance; the same for P_2 .

$$\frac{1}{f_2} = \frac{1}{n_2} \cdot \left(\frac{n_o - n_1}{R_1} + \frac{n_o - n_2}{R_2} \right); \quad \frac{1}{f_1} = \frac{1}{n_1} \cdot \left(\frac{n_o - n_1}{R_1} + \frac{n_o - n_2}{R_2} \right) \quad (5)$$

From the equations (30 and (4) it results:

$$\frac{f_1}{s_1} + \frac{f_2}{s_2} = 1 \quad (6)$$

The lens is plane-convex (fig. 4.3) and its focal distances are:

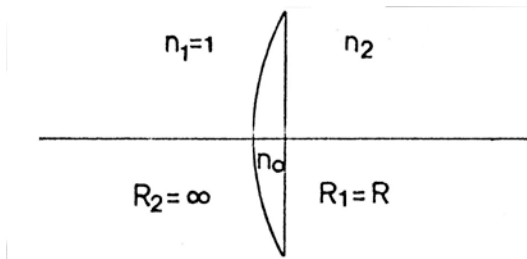

Fig. 4.3

$$f_1 = \frac{n_1 R}{n_o - n_1} = \frac{R}{n_o - 1} \quad ; \quad f_2 = \frac{n_2 R}{n_o - n_2} = \frac{n_2 R}{n_o - 1} \quad (7)$$

b) In the case of Billet lenses, S_1 and S_2 are the real images of the object S and can be considered like coherent light sources (fig. 4.4).

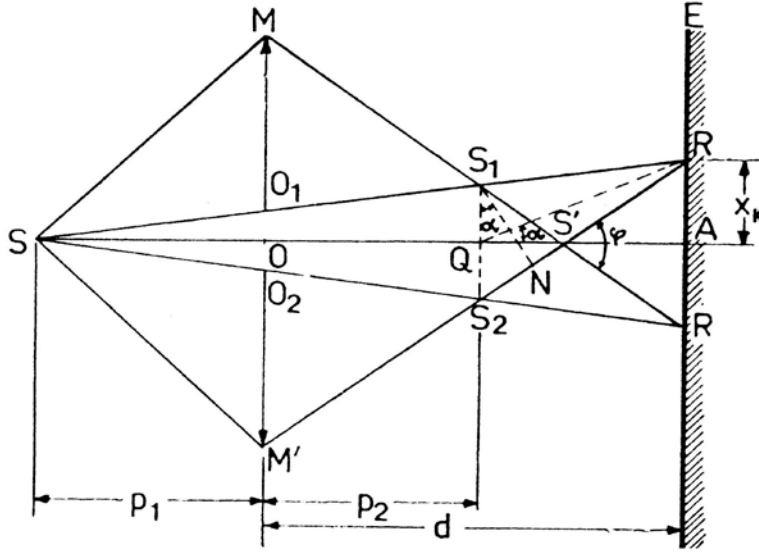

Fig. 4.4

$O_1O_2 = \Delta$ is much more smaller than r :

$$OM = \Delta + r \approx r, \quad SO \approx SO_1 \approx SO_2 = p_1, \quad S_1O_1 = S_2O_2 \approx S'O = p_2, \quad S_1S_2 = \Delta \cdot \left(1 + \frac{p_1}{p_2}\right)$$

We calculate the width of the interference field RR' (fig. 4.4).

$$RR' = 2 \cdot RA = 2 \cdot S'A \cdot \operatorname{tg} \frac{\varphi}{2}, \quad S'A \cong d - p_2, \quad \operatorname{tg} \frac{\varphi}{2} = \frac{r}{p_2}, \quad RR' = 2(d - p_2) \cdot \frac{r}{p_2}$$

Maximum interference condition is:

$$S_2N = k \cdot \lambda$$

The fringe of k order is located at a distance x_k from A :

$$x_k = k \cdot \frac{\lambda(d - p_2)}{\Delta \left(1 + \frac{p_2}{p_1}\right)} \quad (8)$$

The expression of the inter-fringes distance is:

$$i = \frac{\lambda(d - p_2)}{\Delta \left(1 + \frac{p_2}{p_1}\right)} \quad (9)$$

The number of observed fringes on the screen is:

$$N = \frac{RR'}{i} = 2r\Delta \cdot \frac{1 + \frac{p_2}{p_1}}{\lambda p_2} \quad (10)$$

p_2 can be expressed from the lenses' formula:

$$p_2 = \frac{p_1 f}{p_1 - f}$$

Experimental part (Mechanics)

There are given two cylindrical bodies (having identical external shapes and from the same material), two measuring rules, one graduated and other un-graduated, and a vessel with water.

It is known that one of the bodies is homogenous and the other has an internal cavity with the following characteristics:

- the cavity is cylindrical
- has the axis parallel with the axis of the body
- its length is practically equal with that of the body

Determine experimentally and justify theoretically:

- The density of the material the two bodies consist of.
- The radius of the internal cavity.
- The distance between the axis of the cavity and the axis of the cylinder.
- Indicate the sources of errors and appreciate which of them influences more the final results.

Write all the variants you have found.

Solution of the experimental problem

- Determination of the density of the material

The average density of the two bodies was chosen so that the bodies float on the water. Using the mass of the liquid crowded out it is determined the mass of the first body (the homogenous body):

$$m = m_a = V_a \rho_a = S_a H \rho_a \quad (1)$$

where S_a is the area of the base immersed in water, H the length of the cylinder and ρ_a is the density of water.

The mass of the cylinder is:

$$m = V \cdot \rho = \pi R^2 H \rho \quad (2)$$

It results the density of the body:

$$\rho = \rho_a \frac{S_a}{\pi R^2} \quad (3)$$

To calculate the area S_a it is measured the distance h above the water surface (fig. 5.1). Area is composed by the area of the triangle OAB plus the area of the circular sector with the angle $2\pi - 2\theta$.

The triangle area:

$$\frac{1}{2} \cdot 2\sqrt{R^2 - (R-h)^2} \cdot (R-h) = (R-h)\sqrt{h(2R-h)} \quad (4)$$

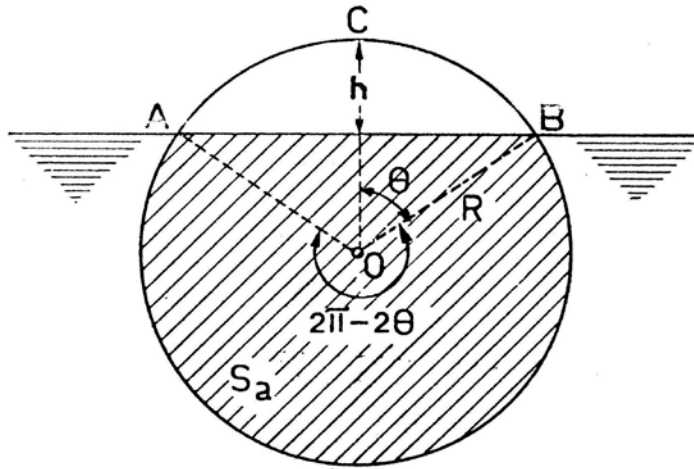

Fig. 5.1

The circular sector area is:

$$\frac{2(\pi - \theta)}{2\pi} \pi R^2 = R^2 \left(\pi - \arccos \frac{R-h}{R} \right) \quad (5)$$

The immersed area is:

$$S_a = (R-h) \sqrt{h(2R-h)} + R^2 \left(\pi - \arccos \frac{R-h}{R} \right) \quad (6)$$

where R and h are measured by the graduated rule.

b) The radius of the cylindrical cavity

The second body (with cavity) is displacing a water mass:

$$m' = m'_a = S'_a H \rho_a \quad (7)$$

where S'_a is area immersed in water.

The mass of the body having the cavity inside is:

$$m' = (V - v) \rho = \pi (R^2 - r^2) H \rho \quad (8)$$

The cavity radius is:

$$r = \sqrt{R^2 - \frac{\rho_a}{\rho} \cdot S'_a} \quad (9)$$

S'_a is determined like S_a .

c) The distance between the cylinder's axis and the cavity axis

We put the second body on the horizontal table (or let it to float in water) and we trace the vertical symmetry axis AB (fig. 5.2).

Using the rule we make an inclined plane. We put the body on this plane and we determine the maximum angle of the inclined plane for the situation the body remains in rest (the body doesn't roll). Taking in account that the weight centre is located on the axis AB on the left side of the cylinder axis (point G in fig. 5.2) and that at equilibrium the weight centre is on the same vertical with the contact point between the cylinder and the inclined plane, we obtain the situation corresponding to the maximum angle of the inclined plane (the diameter AB is horizontal).

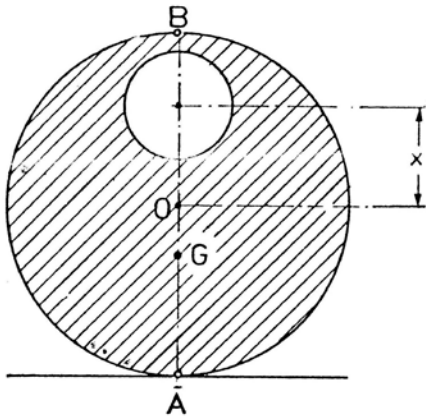

Fig. 5.2

The distance OG is calculated from the equilibrium condition:

$$m' \cdot OG = m_c \cdot x, \text{ (} m_c = \text{the mass dislocated by the cavity)} \quad (10)$$

$$OG = R \sin \alpha \quad (11)$$

$$x = OG \cdot \frac{m'}{m_c} = R \cdot \sin \alpha \cdot \frac{R^2 - r^2}{r^2} \quad (12)$$

d) At every measurement it must be estimated the reading error. Taking in account the expressions for ρ , r and x it is evaluated the maximum error for the determination of these measures.

Problems of the 7th International Physics Olympiad¹ (Warsaw, 1974)

Waldemar Gorzkowski

*Institute of Physics, Polish Academy of Sciences, Warsaw, Poland*²

Abstract

The article contains the competition problems given at the 7th International Physics Olympiad (Warsaw, 1974) and their solutions.

Introduction

The 7th International Physics Olympiad (Warsaw, 1974) was the second one organized in Poland. It took place after a one-year organizational gap, as no country was able to organize the competition in 1973.

The original English version of the problems of the 7th IPhO has not been preserved. We would like to remind that the permanent Secretariat of the IPhOs was established only in 1983; previously the Olympic materials had been collected by individual people in their private archives and, in general, are not complete. English texts of the problems and simplified solutions are available in the book by R. Kunfalvi [1]. Unfortunately, they are somewhat deformed as compared to the originals. Fortunately, we have very precise Polish texts. Also the full solutions in Polish are available. This article is based on the books [2, 3] and article [4].

The competition problems were prepared especially for the 7th IPhO by Andrzej Szymacha (theoretical problems) and Jerzy Langer (experimental problem).

THEORETICAL PROBLEMS

Problem 1

A hydrogen atom in the ground state, moving with velocity v , collides with another hydrogen atom in the ground state at rest. Using the Bohr model find the smallest velocity v_0 of the atom below which the collision must be elastic.

At velocity v_0 the collision may be inelastic and the colliding atoms may emit electromagnetic radiation. Estimate the difference of frequencies of the radiation emitted in the direction of the initial velocity of the hydrogen atom and in the opposite direction as a fraction (expressed in percents) of their arithmetic mean value.

Data:

$$E_i = \frac{me^4}{2\hbar^2} = 13.6 \text{ eV} = 2.18 \cdot 10^{-18} \text{ J}; \text{ (ionization energy of hydrogen atom)}$$

$$m_H = 1.67 \cdot 10^{-27} \text{ kg}; \text{ (mass of hydrogen atom)}$$

¹ This article has been sent for publication in *Physics Competitions* in September 2003

² e-mail: gorzk@ifpan.edu.pl

(m - mass of electron; e - electric charge of electron; \hbar - Planck constant; numerical values of these quantities are not necessary.)

Solution

According to the Bohr model the energy levels of the hydrogen atom are given by the formula:

$$E_n = -\frac{E_i}{n^2},$$

where $n = 1, 2, 3, \dots$. The ground state corresponds to $n=1$, while the lowest excited state corresponds to $n=2$. Thus, the smallest energy necessary for excitation of the hydrogen atom is:

$$\Delta E = E_2 - E_1 = E_i(1 - \frac{1}{4}) = \frac{3}{4} E_i.$$

During an inelastic collision a part of kinetic energy of the colliding particles is converted into their internal energy. The internal energy of the system of two hydrogen atoms considered in the problem cannot be changed by less than ΔE . It means that if the kinetic energy of the colliding atoms with respect to their center of mass is less than ΔE , then the collision must be an elastic one. The value of v_0 can be found by considering the critical case, when the kinetic energy of the colliding atoms is equal to the smallest energy of excitation. With respect to the center of mass the atoms move in opposite direction with velocities $\frac{1}{2}v_0$. Thus

$$\frac{1}{2} m_H \left(\frac{1}{2}v_0\right)^2 + \frac{1}{2} m_H \left(\frac{1}{2}v_0\right)^2 = \frac{3}{4} E_i$$

and

$$v_0 = \sqrt{\frac{3E_i}{m_H}} \quad (\approx 6.26 \cdot 10^4 \text{ m/s}).$$

Consider the case when $v = v_0$. The collision may be elastic or inelastic. When the collision is elastic the atoms remain in their ground states and do not emit radiation. Radiation is possible only when the collision is inelastic. Of course, only the atom excited in the collision can emit the radiation. In principle, the radiation can be emitted in any direction, but according to the text of the problem we have to consider radiation emitted in the direction of the initial velocity and in the opposite direction only. After the inelastic collision both atom are moving (in the laboratory system) with the same velocities equal to $\frac{1}{2}v_0$. Let f denotes the frequency of radiation emitted by the hydrogen atom in the mass center (i.e. at rest). Because of the Doppler effect, in the laboratory system this frequency is observed as (c denotes the velocity of light):

- a) $f_1 = \left(1 + \frac{\frac{1}{2}v_0}{c}\right)f$ - for radiation emitted in the direction of the initial velocity of the hydrogen atom,
- b) $f_2 = \left(1 - \frac{\frac{1}{2}v_0}{c}\right)f$ - for radiation emitted in opposite direction.

The arithmetic mean value of these frequencies is equal to f . Thus the required ratio is

$$\frac{\Delta f}{f} = \frac{f_1 - f_2}{f} = \frac{v_0}{c} \quad (\approx 2 \cdot 10^{-2}\%).$$

In the above solution we took into account that $v_0 \ll c$. Otherwise it would be necessary to use relativistic formulae for the Doppler effect. Also we neglected the recoil of atom(s) in the emission process. One should notice that for the visible radiation or radiation not too far from the visible range the recoil cannot change significantly the numerical results for the critical velocity v_0 and the ratio $\frac{\Delta f}{f}$. The recoil is important for high-energy quanta, but it is not this case.

The solutions were marked according to the following scheme (draft):

- | | |
|--|----------------|
| 1. Energy of excitation | up to 3 points |
| 2. Correct description of the physical processes | up to 4 points |
| 3. Doppler effect | up to 3 points |

Problem 2

Consider a parallel, transparent plate of thickness d – Fig. 1. Its refraction index varies as

$$n = \frac{n_0}{1 - \frac{x}{R}}.$$

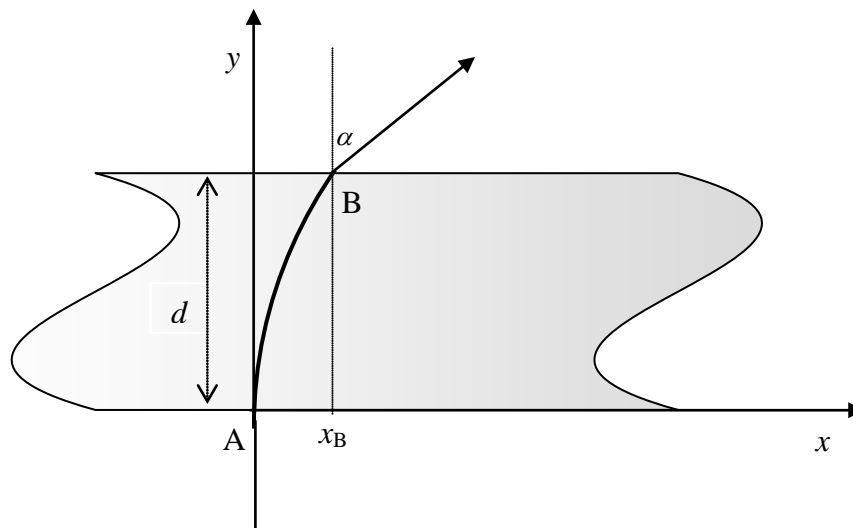

Fig. 1

A light beam enters from the air perpendicularly to the plate at the point A ($x_A = 0$) and emerges from it at the point B at an angle α .

1. Find the refraction index n_B at the point B.
2. Find x_B (i.e. value of x at the point B)
3. Find the thickness d of the plate.

Data:

$$n_0 = 1.2; \quad R = 13 \text{ cm}; \quad \alpha = 30^\circ.$$

Solution

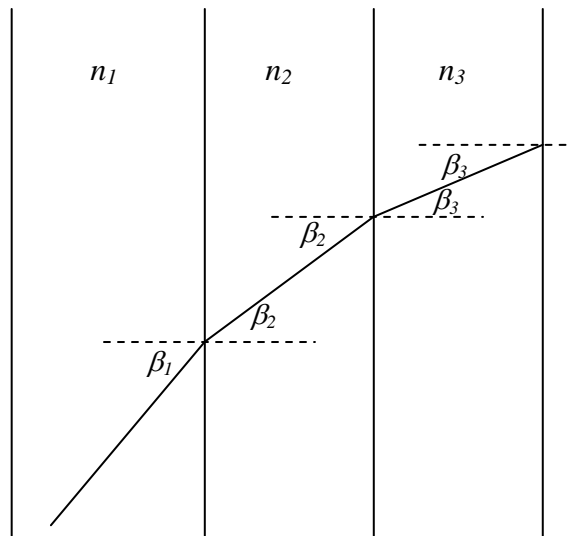

Fig. 2

Consider a light ray passing through a system of parallel plates with different refractive indexes – Fig. 2. From the Snell law we have

$$\frac{\sin \beta_2}{\sin \beta_1} = \frac{n_1}{n_2}$$

i.e.

$$n_2 \sin \beta_2 = n_1 \sin \beta_1.$$

In the same way we get

$$n_3 \sin \beta_3 = n_2 \sin \beta_2, \text{ etc.}$$

Thus, in general:

$$n_i \sin \beta_i = \text{const.}$$

This relation does not involve plates thickness nor their number. So, we may make use of it also in case of continuous dependence of the refractive index in one direction (in our case in the x direction).

Consider the situation shown in Fig. 3.

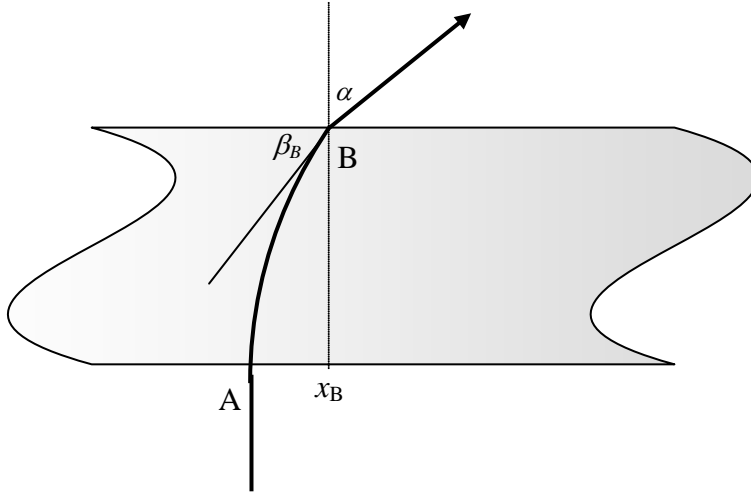

Fig. 3

At the point A the angle $\beta_A = 90^\circ$. The refractive index at this point is n_0 . Thus, we have

$$\begin{aligned} n_A \sin \beta_A &= n_B \sin \beta_B, \\ n_0 &= n_B \sin \beta_B. \end{aligned}$$

Additionally, from the Snell law applied to the refraction at the point B, we have

$$\frac{\sin \alpha}{\sin(90^\circ - \beta_B)} = n_B.$$

Therefore

$$\sin \alpha = n_B \cos \beta_B = n_B \sqrt{1 - \sin^2 \beta_B} = \sqrt{n_B^2 - (n_B \sin \beta_B)^2} = \sqrt{n_B^2 - n_0^2}$$

and finally

$$n_B = \sqrt{n_0^2 + \sin^2 \alpha}.$$

Numerically

$$n_B = \sqrt{\left(\frac{12}{10}\right)^2 + \left(\frac{5}{10}\right)^2} = 1.3$$

The value of x_B can be found from the dependence $n(x)$ given in the text of the problem. We have

$$n_B = n(x_B) = \frac{n_0}{1 - \frac{x_B}{R}},$$

$$x_B = R \left(1 - \frac{n_0}{n_B} \right),$$

Numerically

$$x_B = 1 \text{ cm.}$$

The answer to the third question requires determination of the trajectory of the light ray. According to considerations described at the beginning of the solution we may write (see Fig. 4):

$$n(x) \sin \beta(x) = n_0.$$

Thus

$$\sin \beta(x) = \frac{n_0}{n(x)} = \frac{R-x}{R}.$$

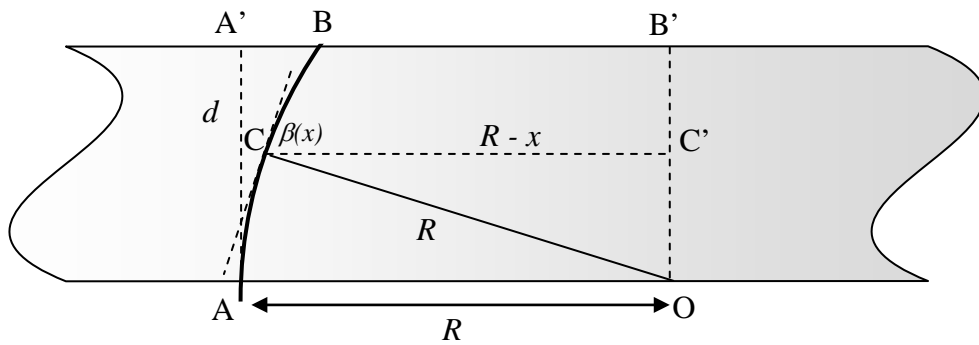

Fig. 4

Consider the direction of the ray crossing a point C on the circle with radius R and center in point O as shown in Fig. 4. We see that

$$\sin \angle COC' = \frac{R-x}{R} = \sin \beta(x).$$

Therefore, the angle $\angle COC'$ must be equal to the angle $\beta(x)$ formed at the point C by the light ray and CC' . It means that at the point C the ray must be tangent to the circle. Moreover, the ray that is tangent to the circle at some point must be tangent also at farther points. Therefore, the ray cannot leave the circle (as long as it is inside the plate)! But at the

beginning the ray (at the point A) is tangent to the circle. Thus, the ray must propagate along the circle shown in Fig. 4 until reaching point B where it leaves the plate.

Already we know that $A'B = 1$ cm. Thus, $B'B = 12$ cm and from the rectangular triangle $BB'O$ we get

$$d = B'O = \sqrt{13^2 - 12^2} \text{ cm} = 5 \text{ cm}.$$

The shape of the trajectory $y(x)$ can be determined also by using more sophisticated calculations. Knowing $\beta(x)$ we find $\text{tg } \beta(x)$:

$$\text{tg } \beta(x) = \frac{R-x}{\sqrt{R^2 - (R-x)^2}}.$$

But $\text{tg } \beta(x)$ is the derivative of $y(x)$. So, we have

$$\frac{dy}{dx} = \frac{R-x}{\sqrt{R^2 - (R-x)^2}} = \frac{d}{dx} \left(\sqrt{R^2 - (R-x)^2} \right).$$

Thus

$$y = \sqrt{R^2 - (R-x)^2} + \text{const}$$

Value of *const* can be found from the condition

$$y(0) = 0.$$

Finally:

$$y = \sqrt{R^2 - (R-x)^2}.$$

It means that the ray moves in the plate along to the circle as found previously.

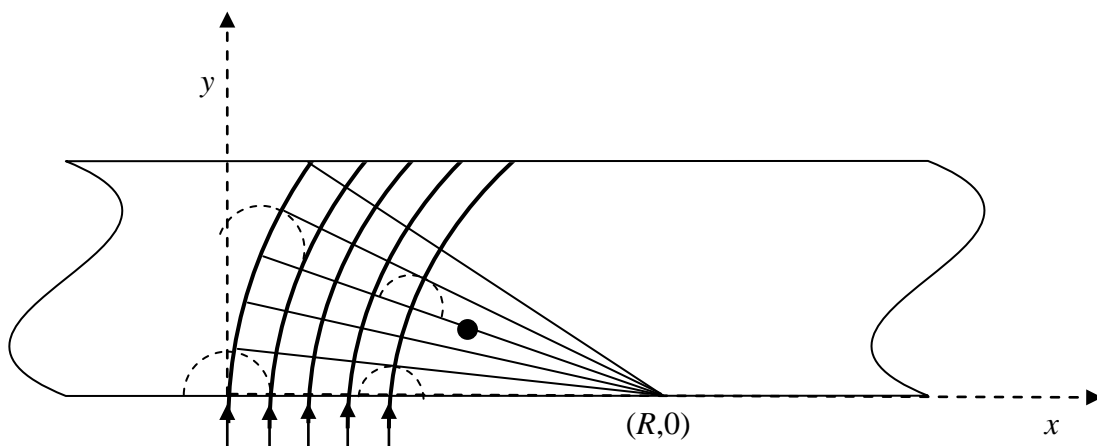

Fig. 5

Now we will present yet another, already the third, method of proving that the light in the plate must move along the circle.

We draw a number of straight lines (inside the plate) close to each other and passing through the point $(R,0)$ - Fig. 5. From the formula given in the text of the problem it follows that the refraction index on each of these lines is inversely proportional to the distance to the point $(R,0)$. Now we draw several arcs with the center at $(R,0)$. It is obvious that the geometric length of each arc between two lines is proportional to the distance to the point $(R,0)$.

It follows from the above that the optical path (a product of geometric length and refractive index) along each arc between the two lines (close to each other) is the same for all the arcs.

Assume that at a certain moment t the wave front reached one of the lines, e.g. the line marked with a black dot in Fig. 5. According to the Huygens principle, the secondary sources on this line emit secondary waves. Their envelope forms the wave front of the real wave at some time $t + \Delta t$. The wave fronts of secondary waves, shown in Fig. 5, have different geometric radii, but - in view of our previous considerations - their optical radii are exactly the same. It means that at the time $t + \Delta t$ the new wave front will correspond to one of the lines passing through $(R,0)$. At the beginning the wave front of the light coincided with the x axis, it means that inside the plate the light will move along the circle with center at the point $(R,0)$.

The solutions were marked according to the following scheme (draft):

- | | |
|--|----------------|
| 1. Proof of the relation $n \sin \beta = \text{const}$ | up to 2 points |
| 2. Correct description of refraction at points A and B | up to 2 points |
| 3. Calculation of x_B | up to 1 point |
| 4. Calculation of d | up to 5 points |

Problem 3

A scientific expedition stayed on an uninhabited island. The members of the expedition had had some sources of energy, but after some time these sources exhausted. Then they decided to construct an alternative energy source. Unfortunately, the island was very quiet: there were no winds, clouds uniformly covered the sky, the air pressure was constant and the temperatures of air and water in the sea were the same during day and night. Fortunately, they found a source of chemically neutral gas outgoing very slowly from a cavity. The pressure and temperature of the gas are exactly the same as the pressure and temperature of the atmosphere.

The expedition had, however, certain membranes in its equipment. One of them was ideally transparent for gas and ideally non-transparent for air. Another one had an opposite property: it was ideally transparent for air and ideally non-transparent for gas. The members of the expedition had materials and tools that allowed them to make different mechanical devices such as cylinders with pistons, valves etc. They decided to construct an engine by using the gas from the cavity.

Show that there is no theoretical limit on the power of an ideal engine that uses the gas and the membranes considered above.

Solution

Let us construct the device shown in Fig. 6. B_1 denotes the membrane transparent for the gas from the cavity, but non-transparent for the air, while B_2 denotes the membrane with opposite property: it is transparent for the air but non-transparent for the gas.

Initially the valve Z_1 is open and the valve Z_2 is closed. In the initial situation, when we keep the piston at rest, the pressure under the piston is equal to $p_0 + p_0$ due to the Dalton law. Let V_0 denotes an initial volume of the gas (at pressure p_0).

Now we close the valve Z_1 and allow the gas in the cylinder to expand. During movement of the piston in the downwards direction we obtain certain work performed by excess pressure inside the cylinder with respect to the atmospheric pressure p_0 . The partial pressure of the gas in the cylinder will be reduced according to the formula $p = p_0 V_0 / V$, where V denotes volume closed by the piston (isothermal process). Due to the membrane B_2 the partial pressure of the air in the cylinder all the time is p_0 and balances the air pressure outside the cylinder. It means that only the gas from the cavity effectively performs the work.

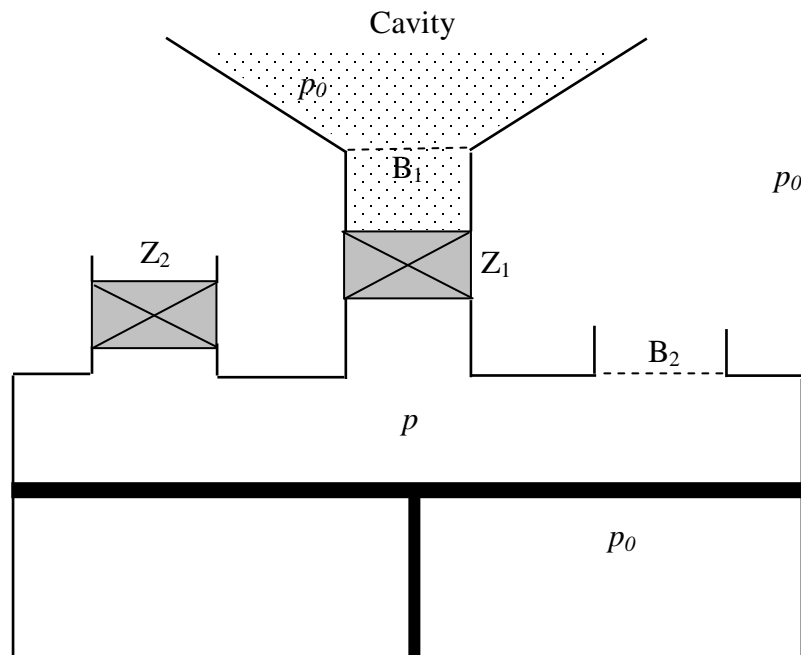

Fig. 6

Consider the problem of limits for the work that can be performed during isothermal expansion of an initial portion of the gas. Let us analyze the graph of the function $p_0 V_0 / V$ versus V shown in Fig. 7.

It is obvious that the amount of work performed by the gas during isothermal expansion from V_0 to V_k is represented by the area under the curve (shown in the graph) from V_0 to V_k . Of course, the work is proportional to V_0 . We shall prove that for large enough V_k the work can be arbitrarily large.

Consider $V = V_0, 2V_0, 4V_0, 8V_0, 16V_0, \dots$ It is clear that the rectangles I, II, III, ... (see Fig. 7) have the same area and that one may draw arbitrarily large number of such rectangles

under the considered curve. It means that during isothermal expansion of a given portion of the gas we may obtain arbitrarily large work (at the cost of the heat taken from the surrounding) – it is enough to take V_k large enough.

After reaching V_k we open the valve Z_2 and move the piston to its initial position without performing any work. The cycle can be repeated as many times as we want.

In the above considerations we focused our attention on the work obtained during one cycle only. We entirely neglected dynamics of the process, while each cycle lasts some time. One may think that - in principle - the length of the cycle increases very rapidly with the effective work we obtain. This would limit the power of the device we consider.

Take, however, into account that, by proper choice of various parameters of the device, the time taken by one cycle can be made small and the initial volume of the gas V_0 can be made arbitrarily large (we consider only theoretical possibilities – we neglect practical difficulties entirely). E.g. by taking large size of the membrane B_1 and large size of the piston we may minimize the time of taking the initial portion of the gas V_0 from the cavity and make this portion very great.

In our analysis we neglected all losses, friction, etc. One should remark that there are no theoretical limits for them. These losses, friction etc. can be made negligibly small.

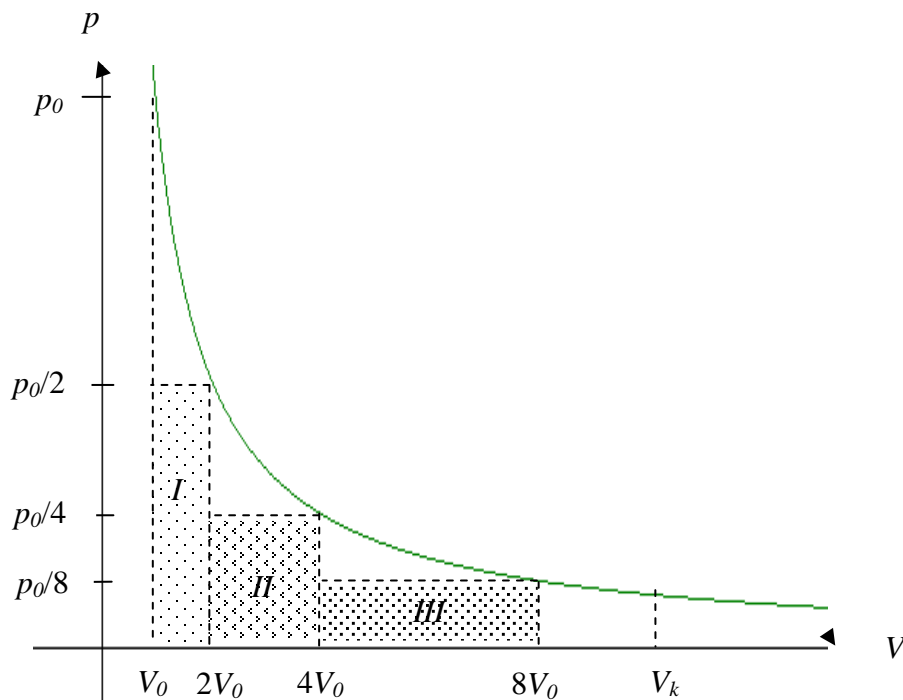

Fig. 7

The device we analyzed is very interesting: it produces work at cost of heat taken from surrounding without any difference in temperatures. Does this contradict the second law of thermodynamics? No! It is true that there is no temperature difference in the system, but the work of the device makes irreversible changes in the system (mixing of the gas from the cavity and the air).

The solutions were marked according to the following scheme (draft):

- | | |
|---|----------------|
| 1. Model of an engine and its description | up to 4 points |
| 2. Proof that there is no theoretical limit for power | up to 4 points |
| 3. Remark on II law of thermodynamics | up to 2 points |

EXPERIMENTAL PROBLEM

In a "black box" there are two identical semiconducting diodes and one resistor connected in some unknown way. By using instruments provided by the organizers find the resistance of the resistor.

Remark: One may assume that the diode conducts current in one direction only.

List of instruments: two universal volt-ammeters (without ohmmeters), battery, wires with endings, graph paper, resistor with regulated resistance.

Solution

At the beginning we perform preliminary measurements by using the circuit shown in Fig. 8. For two values of voltage U_1 and U_2 , applied to the black box in both directions, we measure four values of current: $I(U_1)$, $I(U_2)$, $I(-U_1)$ and $I(-U_2)$. In this way we find that:

1. The black box conducts current in both directions;
2. There is an asymmetry with respect to the sign of the voltage;
3. In both directions current is a nonlinear function of voltage.

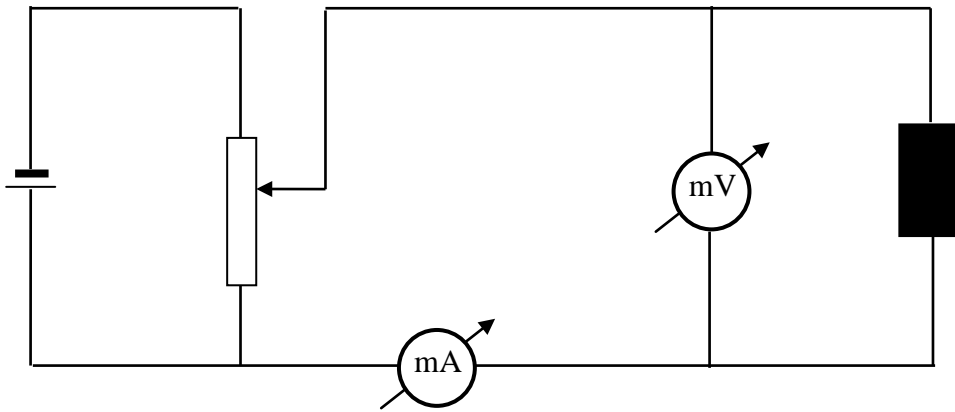
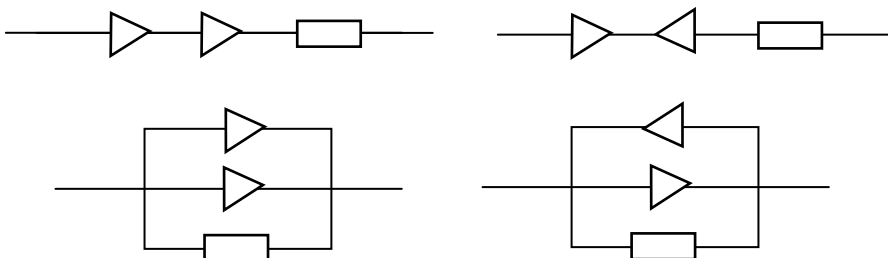

Fig. 8

The diodes and resistor can be connected in a limited number of ways shown in Fig. 9 (connections that differ from each other in a trivial way have been omitted).



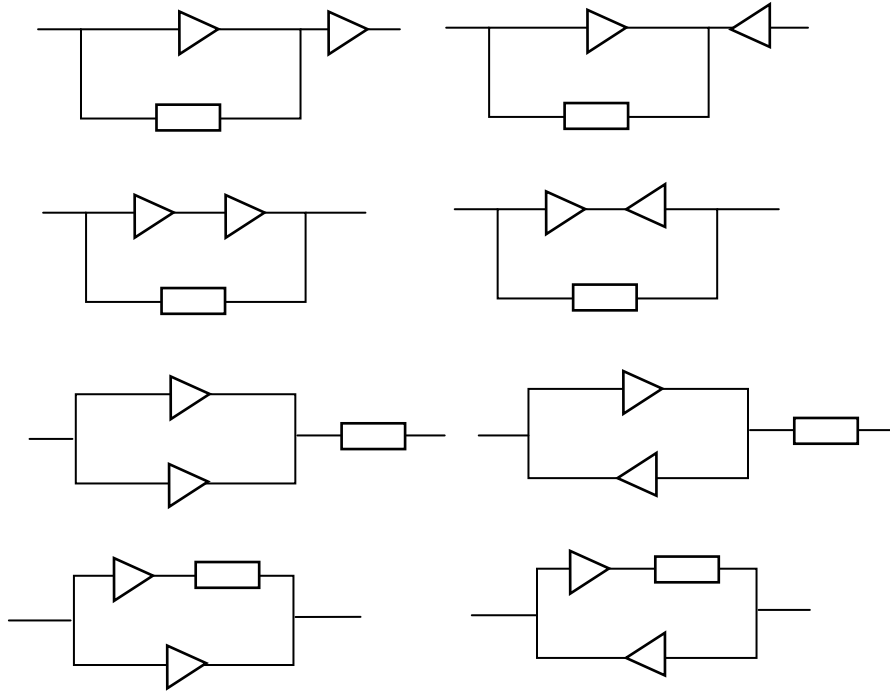

Fig. 9

Only one of these connections has the properties mentioned at the beginning. It is:

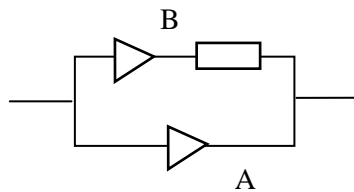

Fig. 10

For absolute values of voltages we have

$$U_R = U_B - U_A = \Delta U,$$

where U_R denotes voltage on the resistor when a current I flows through the branch B, U_A - voltage on the black box when the current I flows through the branch A, and U_B - voltage on the black box when the current I flows through the branch B.

Therefore

$$R = \frac{U_R(I)}{I} = \frac{U_B(I) - U_A(I)}{I} = \frac{\Delta U}{I}.$$

It follows from the above that it is enough to take characteristics of the black box in both directions: by subtraction of the corresponding points (graphically) we obtain a straight line (example is shown in Fig. 11) whose slope allows to determine the value of R .

The solutions were marked according to the following scheme (draft):

Theoretical part:

1. Proper circuit and method allowing determination of connections the elements in the black box up to 6 points
2. Determination of R (principle) up to 2 points
3. Remark that measurements at the same voltage in both directions make the error smaller up to 1 point
4. Role of number of measurements (affect on errors) up to 1 point

Experimental part:

1. Proper use of regulated resistor as potentiometer up to 2 points
2. Practical determination of R (including error) up to 4 points
3. Proper use of measuring instruments up to 2 points
4. Taking into account that temperature of diodes increases during measurements up to 1 point
5. Taking class of measuring instruments into account up to 1 point

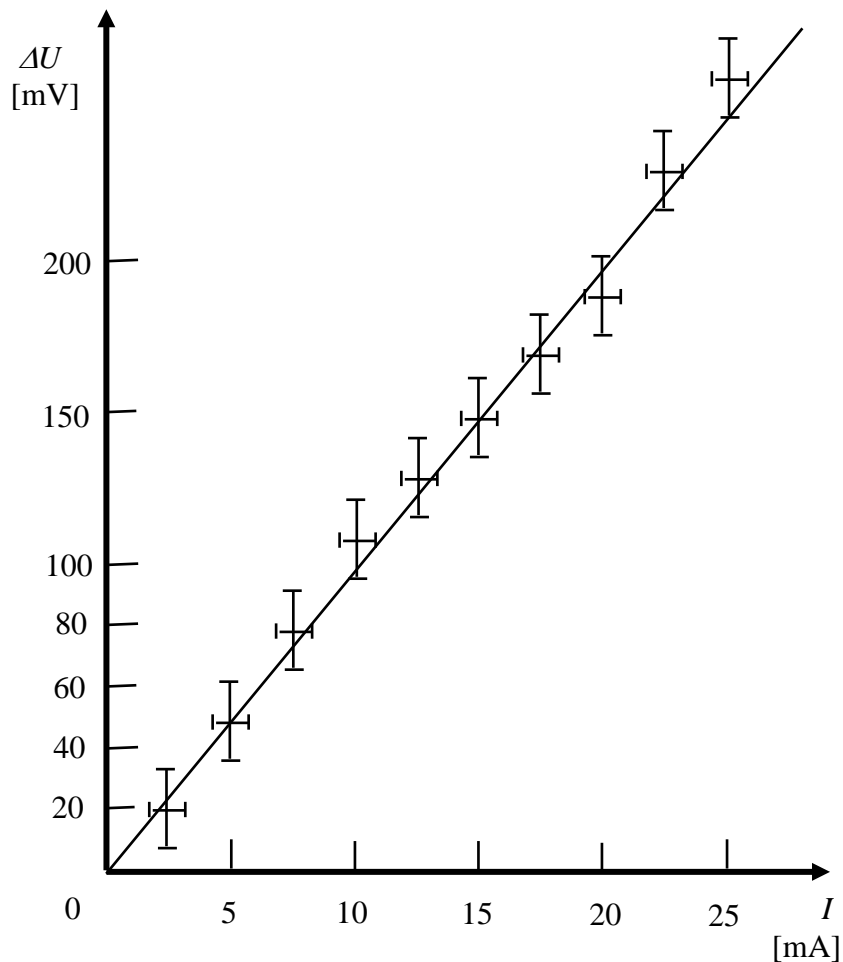

Fig. 11

Acknowledgement

Author wishes to express many thanks to Prof. Jan Mostowski for reading the text and for many valuable comments and remarks that allowed improving the final version.

Literature

- [1] **R. Kurfalvi**, *Collection of Competition Tasks from the Ist trough XVth International Physics Olympiads, 1967 – 1984*, Roland Eotvos Physical Society and UNESCO, Budapest 1985
- [2] **W. Gorzkowski**, *Olimpiady Fizyczne – XXIII I XXIV*, WSiP, Warszawa 1977
- [3] **W. Gorzkowski**, *Zadania z fizyki z całego świata (z rozwiązaniami) - 20 lat Międzynarodowych Olimpiad Fizycznych*, WNT, Warszawa 1994 [ISBN 83-204-1698-1]
- [4] **W. Gorzkowski**, *VII Międzynarodowa Olimpiada Fizyczna*, *Fizyka w Szkole*, nr **3/75**, pp. 23 – 28

Problems of the 8th International Physics Olympiad (Güstrow, 1975)

Gunnar Friege¹ & Gunter Lind

Introduction

The 8th International Physics Olympiad took place from the 7.7. to the 12.7. 1975 in Güstrow, in the German Democratic Republic (GDR). Altogether, 9 countries with 45 pupils participated. The teams came from Bulgaria, the German Democratic Republic, the Federal Republic of Germany (FRG), France, Poland, Rumania, Tchechoslowakia, Hungary and the USSR. The entire event took place in the pedagogic academy of Güstrow. Pupils and leaders were accommodated inside the university academy complex. On the schedule there was the competition and receptions as well as excursions to Schwerin, Rostock, and Berlin were offered. The delegation of the FRG reported of a very good organisation of the olympiad.

The problems and solutions of the 8th International Physics Olympiad were created by a commission of university physics professors and lecturers. The same commission set marking schemes and conducted the correction of the tests. The correction was carried out very quickly and was considered as righteous and, in cases of doubt, as very generous.

The main competition consisted of a 5 hour test in theory and a 4.5 hour experimental test. The time for the theoretical part was rather short and for the experimental part rather long. The problems originated from central areas of classical physics. The theoretical problems were relatively difficult, although solvable with good physics knowledge taught at school. The level of difficulty of the experimental problem was adequate. There were no additional devices necessary for the solution of the problems. Only basic formula knowledge was requested, and could be demanded from all pupils. Critics were only uttered concerning the second theoretical problem (thick lens). This problem requested relatively little physical understanding, but tested the mathematical skills and the routine in approaching problems (e.g. correct distinction of cases). However, it is also difficult to find substantial physics problems in the area of geometrical optics.

¹ Remark: This article was written due to the special request to us by Dr. W. Gorzkowski, in order to close one of the last few gaps in the IPhO-report collection.

Contact: Dr. Gunnar Friege, Leibniz-Institute for Science Education (IPN) at the University of Kiel, Olshausenstr. 62, 24098 Kiel, Germany, friege@ipn.uni-kiel.de

Altogether 50 points were the maximum to achieve; 30 in the theoretical test and 20 in the experimental test. The best contestant came from the USSR and had 43 points. The first prize (gold medal) was awarded with 39 points, the second prize (silver medal) with 34 points, the third prize (bronze medal) with 28 points and the fourth prize (honourable mention) with 22 points. Among the 45 contestants, 7 I. prizes, 9 II. prizes, 12 III. prizes and 8 IV. prizes were awarded, meaning that 80 % of all contestants were awarded.

The following problem descriptions and solution are based mainly on a translation of the original German version from 1975. Because the original drafts are not well preserved, some new sketches were drawn. We also gave the problems headlines and the solutions are in more detail.

Theoretical problem 1: “Rotating rod”

A rod revolves with a constant angular velocity ω around a vertical axis A. The rod includes a fixed angle of $\pi/2 - \alpha$ with the axis. A body of mass m can glide along the rod. The coefficient of friction is $\mu = \tan\beta$. The angle β is called „friction angle“.

- a) Determine the angles α under which the body remains at rest and under which the body is in motion if the rod is not rotating (i.e. $\omega = 0$).
- b) The rod rotates with constant angular velocity $\omega > 0$. The angle α does not change during rotation. Find the condition for the body to remain at rest relative to the rod.

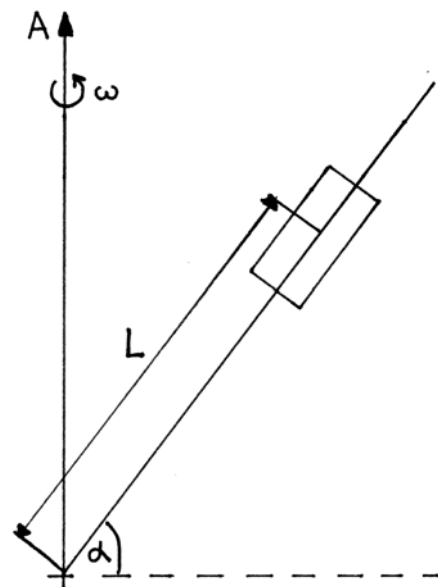

You can use the following relations:

$$\sin(\alpha \pm \beta) = \sin \alpha \cdot \cos \beta \pm \cos \alpha \cdot \sin \beta$$

$$\cos(\alpha \pm \beta) = \cos \alpha \cdot \cos \beta \mp \sin \alpha \cdot \sin \beta$$

Solution of problem 1:

a) $\omega = 0$:

The forces in this case are (see figure):

$$\vec{G} = \vec{Z} + \vec{N} = m \cdot \vec{g} \quad (1),$$

$$|\vec{Z}| = m \cdot g \cdot \sin \alpha = Z \quad (2),$$

$$|\vec{N}| = m \cdot g \cdot \cos \alpha = N \quad (3),$$

$$|\vec{R}| = \mu \cdot N = \mu \cdot m \cdot g \cdot \cos \alpha = R \quad (4).$$

[\vec{R} : force of friction]

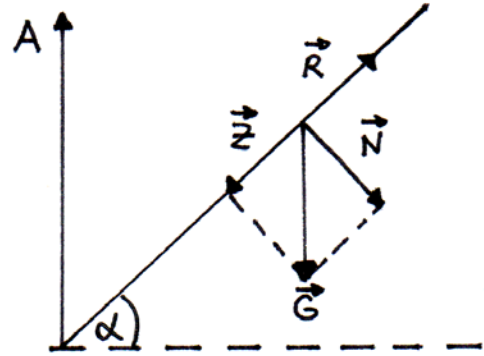

The body is at rest relative to the rod, if $Z \leq R$. According to equations (2) and (4) this is equivalent to $\tan \alpha \leq \tan \beta$. That means, the body is at rest relative to the rod for $\alpha \leq \beta$ and the body moves along the rod for $\alpha > \beta$.

b) $\omega > 0$:

Two different situations have to be considered: 1. $\alpha > \beta$ and 2. $\alpha \leq \beta$.

If the rod is moving ($\omega \neq 0$) the forces are $\vec{G} = m \cdot \vec{g}$ and $|\vec{F}_r| = m \cdot r \cdot \omega^2$.

From the parallelogram of forces (see figure):

$$\vec{Z} + \vec{N} = \vec{G} + \vec{F}_r \quad (5).$$

The condition of equilibrium is:

$$|\vec{Z}| = \mu |\vec{N}| \quad (6).$$

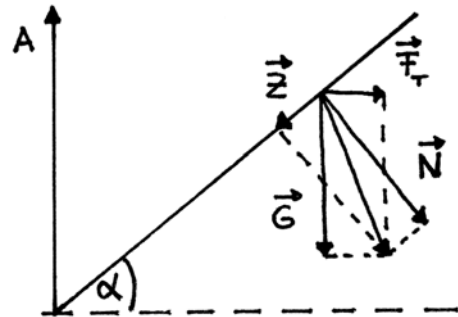

Case 1: \vec{Z} is oriented downwards, i.e. $g \cdot \sin \alpha > r \cdot \omega^2 \cdot \cos \alpha$.

$$|\vec{Z}| = m \cdot g \cdot \sin \alpha - m \cdot r \cdot \omega^2 \cdot \cos \alpha \quad \text{and} \quad |\vec{N}| = m \cdot g \cdot \cos \alpha + m \cdot r \cdot \omega^2 \cdot \sin \alpha$$

Case 2: \vec{Z} is oriented upwards, i.e. $g \cdot \sin \alpha < r \cdot \omega^2 \cdot \cos \alpha$.

$$|\vec{Z}| = -m \cdot g \cdot \sin \alpha + m \cdot r \cdot \omega^2 \cdot \cos \alpha \quad \text{and} \quad |\vec{N}| = m \cdot g \cdot \cos \alpha + m \cdot r \cdot \omega^2 \cdot \sin \alpha$$

It follows from the condition of equilibrium equation (6) that

$$\pm (g \cdot \sin \alpha - r \cdot \omega^2 \cdot \cos \alpha) = \tan \beta \cdot (g \cdot \cos \alpha + r \cdot \omega^2 \cdot \sin \alpha) \quad (7).$$

Algebraic manipulation of equation (7) leads to:

$$g \cdot \sin(\alpha - \beta) = r \cdot \omega^2 \cdot \cos(\alpha - \beta) \quad (8),$$

$$g \cdot \sin(\alpha + \beta) = r \cdot \omega^2 \cdot \cos(\alpha + \beta) \quad (9).$$

That means,

$$r_{1,2} = \frac{g}{\omega^2} \cdot \tan(\alpha \mp \beta) \quad (10).$$

The body is at rest relative to the rotating rod in the case $\alpha > \beta$ if the following inequalities hold:

$$r_1 \leq r \leq r_2 \quad \text{with } r_1, r_2 > 0 \quad (11)$$

or

$$L_1 \leq L \leq L_2 \quad \text{with } L_1 = r_1 / \cos \alpha \text{ and } L_2 = r_2 / \cos \alpha \quad (12).$$

The body is at rest relative to the rotating rod in the case $\alpha \leq \beta$ if the following inequalities hold:

$$0 \leq r \leq r_2 \quad \text{with } r_1 = 0 \text{ (since } r_1 < 0 \text{ is not a physical solution), } r_2 > 0 \quad (13).$$

Inequality (13) is equivalent to

$$0 \leq L \leq L_2 \quad \text{with } L_2 = r_2 / \cos \alpha > 0 \quad (14).$$

Theoretical problem 2: "Thick lens"

The focal length f of a thick glass lens in air with refractive index n , radius curvatures r_1, r_2 and vertex distance d (see figure) is given by:

$$f = \frac{n r_1 r_2}{(n-1)[n(r_2 - r_1) + d(n-1)]}$$

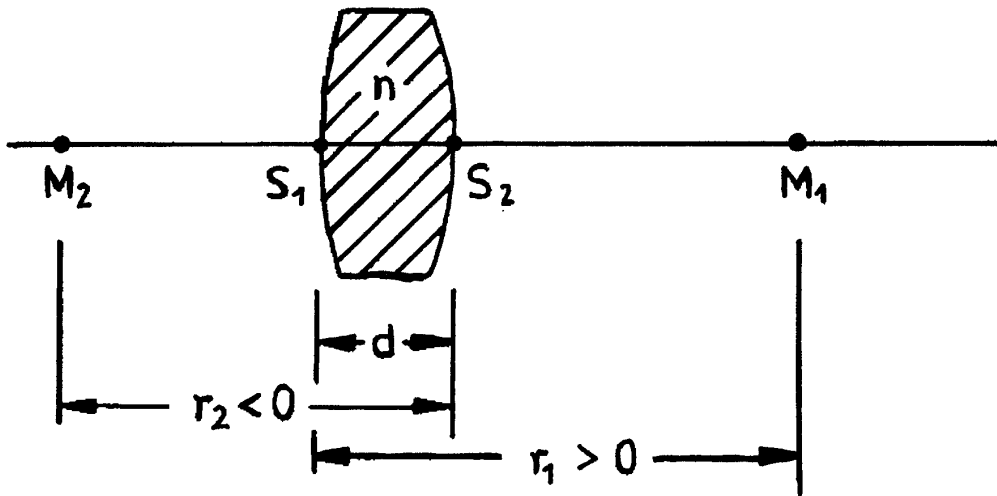

Remark: $r_i > 0$ means that the central curvature point M_i is on the right side of the aerial vertex S_i , $r_i < 0$ means that the central curvature point M_i is on the left side of the aerial vertex S_i ($i = 1, 2$).

For some special applications it is required, that the focal length is independent from the wavelength.

- For how many different wavelengths can the same focal length be achieved?
- Describe a relation between r_i ($i = 1, 2$), d and the refractive index n for which the required wavelength independence can be fulfilled and discuss this relation.

Sketch possible shapes of lenses and mark the central curvature points M_1 and M_2 .

- Prove that for a given planconvex lens a specific focal length can be achieved by only one wavelength.
- State possible parameters of the thick lens for two further cases in which a certain focal length can be realized for one wavelength only. Take into account the physical and the geometrical circumstances.

Solution of problem 2:

- The refractive index n is a function of the wavelength λ , i.e. $n = n(\lambda)$. According to the given formula for the focal length f (see above) which for a given f yields to an equation quadratic in n there are at most two different wavelengths (indices of refraction) for the same focal length.

- If the focal length is the same for two different wavelengths, then the equation

$$f(\lambda_1) = f(\lambda_2) \quad \text{or} \quad f(n_1) = f(n_2) \quad (1)$$

holds. Using the given equation for the focal length it follows from equation (1):

$$\frac{n_1 r_1 r_2}{(n_1 - 1)[n_1(r_2 - r_1) + d(n_1 - 1)]} = \frac{n_2 r_1 r_2}{(n_2 - 1)[n_2(r_2 - r_1) + d(n_2 - 1)]}$$

Algebraic calculations lead to:

$$r_1 - r_2 = d \cdot \left(1 - \frac{1}{n_1 n_2} \right) \quad (2).$$

If the values of the radii r_1, r_2 and the thickness satisfy this condition the focal length will be the same for two wavelengths (indices of refraction). The parameters in this equation are subject to some physical restrictions: The indices of refraction are greater than 1 and the thickness of the lens is greater than 0 m. Therefore, from equation (2) the relation

$$d > r_1 - r_2 > 0 \quad (3)$$

is obtained.

The following table shows a discussion of different cases:

r_1	r_2	condition	shape of the lens	centre of curvature
$r_1 > 0$	$r_2 > 0$	$0 < r_1 - r_2 < d$ or $r_2 < r_1 < d + r_2$		M_2 is always right of M_1 . $\overline{M_1 M_2} < \overline{S_1 S_2}$
$r_1 > 0$	$r_2 < 0$	$r_1 + r_2 < d$		Order of points: $S_1 M_1 M_2 S_2$
$r_1 < 0$	$r_2 > 0$	never fulfilled		
$r_1 < 0$	$r_2 < 0$	$0 < r_2 - r_1 < d$ or $ r_1 < r_2 < d + r_1 $		M_2 is always right of M_1 . $\overline{M_1 M_2} < \overline{S_1 S_2}$

- c) The radius r_1 or the radius r_2 is infinite in the case of the planconvex lens. In the following it is assumed that r_1 is infinite and r_2 is finite.

$$\lim_{r_1 \rightarrow \infty} f = \lim_{r_1 \rightarrow \infty} \frac{n r_2}{(n-1) \left[n \left(\frac{r_2}{r_1} - 1 \right) + (n-1) \frac{d}{r_1} \right]} = \frac{r_2}{1-n} \quad (4)$$

Equation (4) means, that for each wavelength (refractive index) there exists a different value of the focal length.

- d) From the given formula for the focal length (see problem formulation) one obtains the following quadratic equation in n :

$$A \cdot n^2 + B \cdot n + C = 0 \quad (5)$$

with $A = (r_2 - r_1 + d) \cdot f$, $B = -[f \cdot (r_2 - r_1) + 2 \cdot f \cdot d + r_1 \cdot r_2]$ and $C = f \cdot d$.

Solutions of equation (5) are:

$$n_{1,2} = -\frac{B}{2 \cdot A} \pm \sqrt{\frac{B^2}{4 \cdot A^2} - \frac{C}{A}} \quad (6).$$

Equation (5) has only one physical correct solution, if...

- I) $A = 0$ (i.e., the coefficient of n^2 in equation (5) vanishes)

In this case the following relationships exists:

$$r_1 - r_2 = d \quad (7),$$

$$n = \frac{f \cdot d}{f \cdot d + r_1 \cdot r_2} > 1 \quad (8).$$

- II) $B = 0$ (i.e. the coefficient of n in equation (5) vanishes)

In this case the equation has a positive and a negative solution. Only the positive solution makes sense from the physical point of view. It is:

$$f \cdot (r_2 - r_1) + 2 \cdot f \cdot d + r_1 \cdot r_2 = 0 \quad (9),$$

$$n^2 = -\frac{C}{A} = -\frac{d}{(r_2 - r_1 + d)} > 1 \quad (10),$$

- III) $B^2 = 4 AC$

In this case two identical real solutions exist. It is:

$$\left[f \cdot (r_2 - r_1) + 2 \cdot f \cdot d + r_1 \cdot r_2 \right]^2 = 4 \cdot (r_2 - r_1 + d) \cdot f^2 \cdot d \quad (11),$$

$$n = -\frac{B}{2 \cdot A} = \frac{f \cdot (r_2 - r_1) + 2 \cdot f \cdot d + r_1 \cdot r_2}{2 \cdot f \cdot (r_2 - r_1 + d)} > 1 \quad (12).$$

Theoretical problem 3: “Ions in a magnetic field”

A beam of positive ions (charge $+e$) of the same and constant mass m spread from point Q in different directions in the plane of paper (see figure²). The ions were accelerated by a voltage U . They are deflected in a uniform magnetic field B that is perpendicular to the plane of paper. The boundaries of the magnetic field are made in a way that the initially diverging ions are focussed in point A

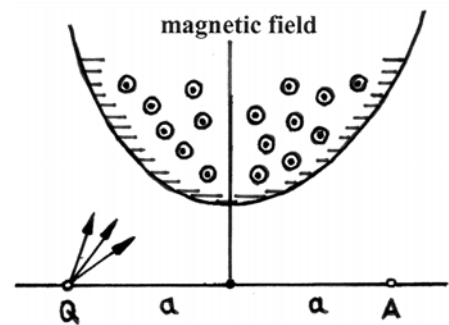

($\overline{QA} = 2 \cdot a$). The trajectories of the ions are symmetric to the middle perpendicular on \overline{QA} .

² Remark: This illustrative figure was not part of the original problem formulation.

Among different possible boundaries of magnetic fields a specific type shall be considered in which a contiguous magnetic field acts around the middle perpendicular and in which the points Q and A are in the field free area.

- Describe the radius curvature R of the particle path in the magnetic field as a function of the voltage U and the induction B .
- Describe the characteristic properties of the particle paths in the setup mentioned above.
- Obtain the boundaries of the magnetic field boundaries by geometrical constructions for the cases $R < a$, $R = a$ and $R > 0$.
- Describe the general equation for the boundaries of the magnetic field.

Solution of problem 3:

- The kinetic energy of the ion after acceleration by a voltage U is:

$$\frac{1}{2} mv^2 = eU \tag{1}$$

From equation (1) the velocity of the ions is calculated:

$$v = \sqrt{\frac{2 \cdot e \cdot U}{m}} \tag{2}$$

On a moving ion (charge e and velocity v) in a homogenous magnetic field B acts a Lorentz force F . Under the given conditions the velocity is always perpendicular to the magnetic field. Therefore, the paths of the ions are circular with Radius R . Lorentz force and centrifugal force are of the same amount:

$$e \cdot v \cdot B = \frac{m \cdot v^2}{R} \tag{3}$$

From equation (3) the radius of the ion path is calculated:

$$R = \frac{1}{B} \sqrt{\frac{2 \cdot m \cdot U}{e}} \tag{4}$$

- All ions of mass m travel on circular paths of radius $R = v \cdot m / e \cdot B$ inside the magnetic field. Leaving the magnetic field they fly in a straight line along the last tangent. The centres of curvature of the ion paths lie on the middle perpendicular on \overline{QA} since the magnetic field is assumed to be symmetric to the middle perpendicular on \overline{QA} . The paths of the focussed ions are above \overline{QA} due to the direction of the magnetic field.

$R < a$

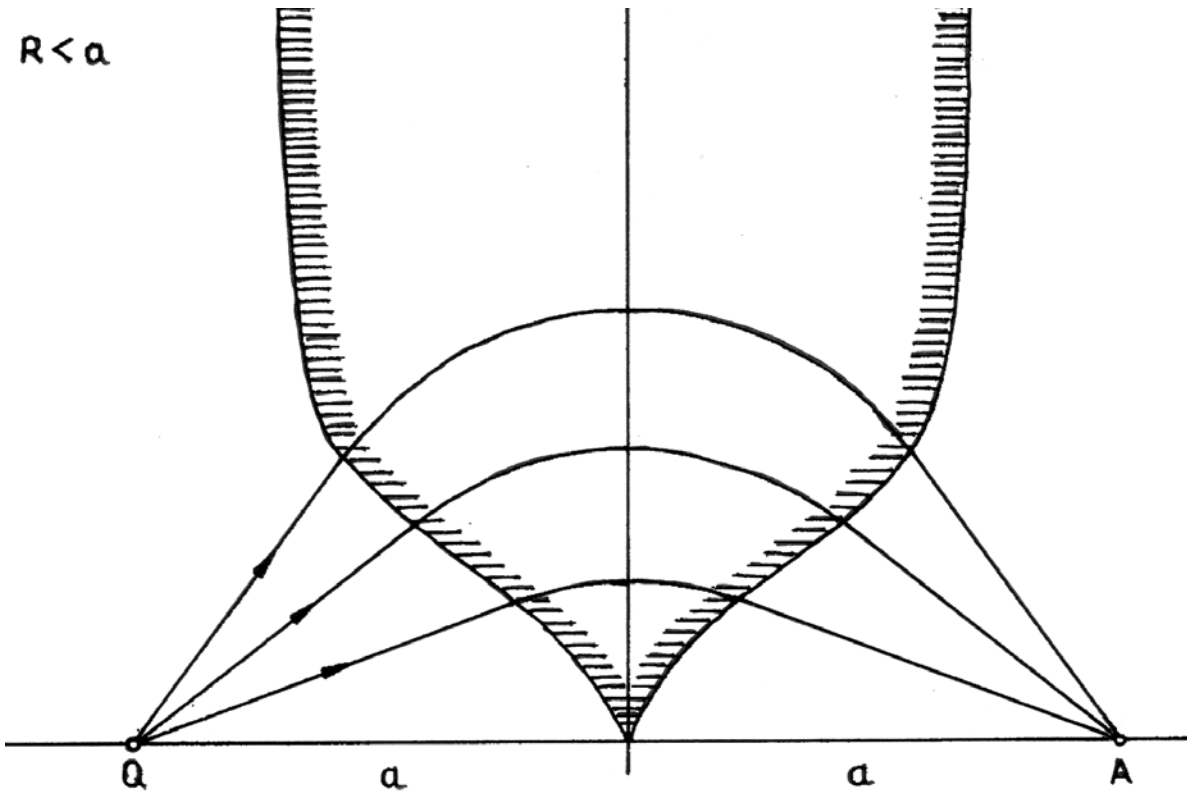

$R = a$

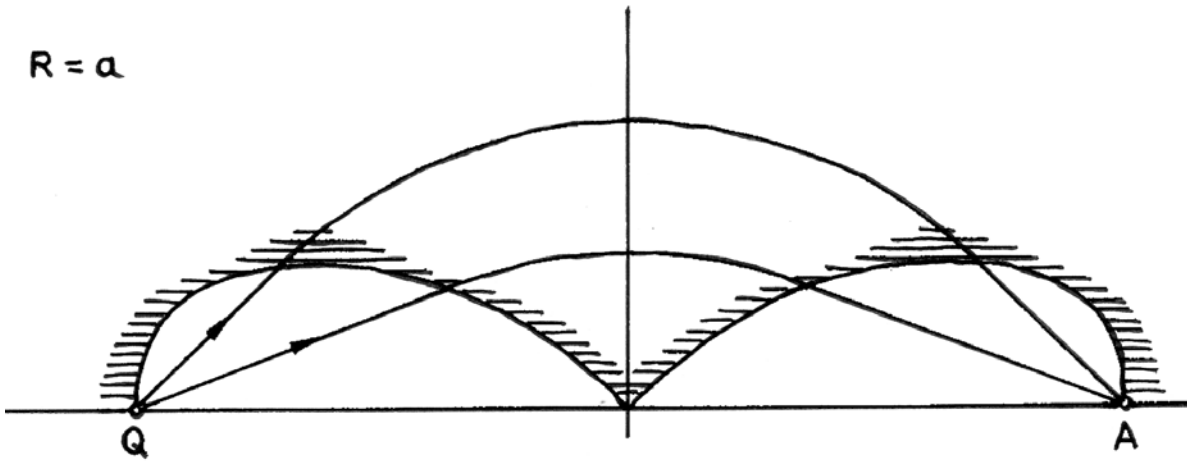

$R > a$

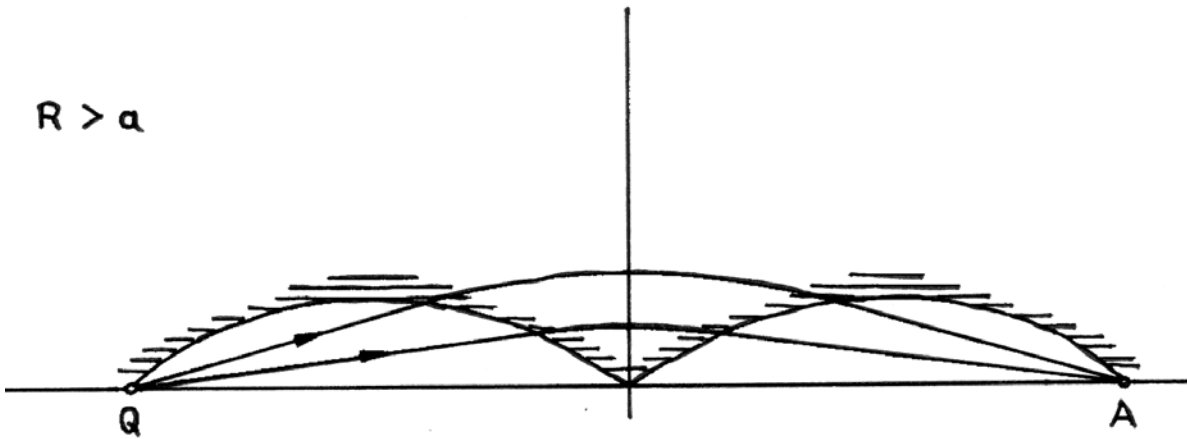

c) The construction method of the boundaries of the magnetic fields is based on the considerations in part b:

- Sketch circles of radius R and different centres of curvature on the middle perpendicular on \overline{QA} .
- Sketch tangents on the circle with either point Q or point A on these straight lines.
- The points of tangency make up the boundaries of the magnetic field. If $R > a$ then not all ions will reach point A. Ions starting at an angle steeper than the tangent at Q, do not arrive in A. The figure on the last page shows the boundaries of the magnetic field for the three cases $R < a$, $R = a$ and $R > a$.

d) It is convenient to deduce a general equation for the boundaries of the magnetic field in polar coordinates (r, φ) instead of using cartesian coordinates (x, y) .

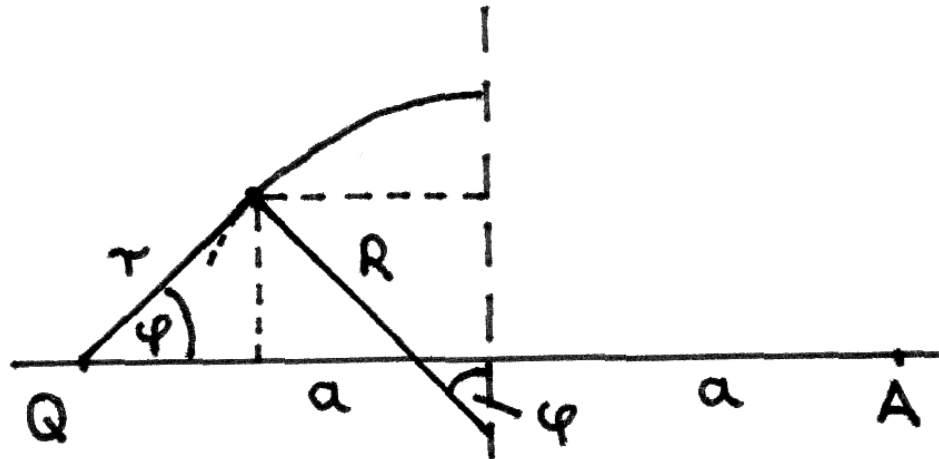

The following relation is obtained from the figure:

$$r \cdot \cos \varphi + R \sin \varphi = a \tag{7}$$

The boundaries of the magnetic field are given by:

$$r = \frac{a}{\cos \varphi} \left(1 - \frac{R}{a} \sin \varphi \right) \tag{8}$$

Experimental problem: “Semiconductor element”

In this experiment a semiconductor element (——), an adjustable resistor (up to 140 Ω), a fixed resistor (300 Ω), a 9-V-direct voltage source, cables and two multimeters are at disposal. It is not allowed to use the multimeters as ohmmeters.

- a) Determine the current-voltage-characteristics of the semiconductor element taking into account the fact that the maximum load permitted is 250 mW. Write down your data in tabular form and plot your data. Before your measurements consider how an overload of the semiconductor element can surely be avoided and note down your thoughts. Sketch the circuit diagram of the chosen setup and discuss the systematic errors of the circuit.
- b) Calculate the resistance (dynamic resistance) of the semiconductor element for a current of 25 mA.
- c) Determine the dependence of output voltage U_2 from the input voltage U_1 by using the circuit described below. Write down your data in tabular form and plot your data.

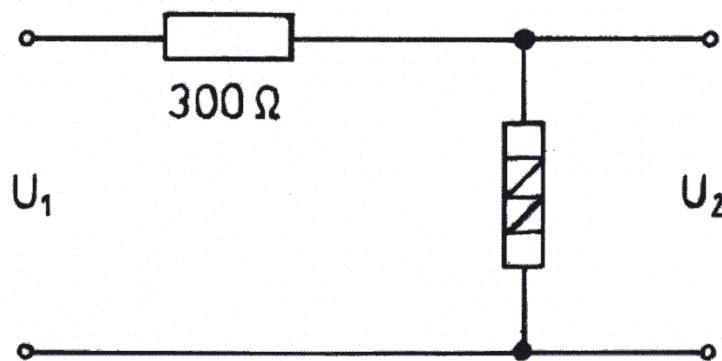

The input voltage U_1 varies between 0 V and 9 V. The semiconductor element is to be placed in the circuit in such a manner, that U_2 is as high as possible. Describe the entire circuit diagram in the protocol and discuss the results of the measurements.

- d) How does the output voltage U_2 change, when the input voltage is raised from 7 V to 9 V? Explain qualitatively the ratio $\Delta U_1 / \Delta U_2$.
- e) What type of semiconductor element is used in the experiment? What is a practical application of the circuit shown above?

Hints: The multimeters can be used as voltmeter or as ammeter. The precision class of these instruments is 2.5% and they have the following features:

measuring range	50 μA	300 μA	3 mA	30 mA	300 mA	0,3 V	1 V	3 V	10 V
internal resistance	2 kΩ	1 kΩ	100 Ω	10 Ω	1 Ω	6 kΩ	20 kΩ	60 kΩ	200 kΩ

Solution of the experimental problem:

- a) Some considerations: the product of the voltage across the semiconductor element U and current I through this element is not allowed to be larger than the maximum permitted load of 250 mW. Therefore the measurements have to be processed in a way, that the product $U \cdot I$ is always smaller than 250 mW.

The figure shows two different circuit diagram that can be used in this experiment:

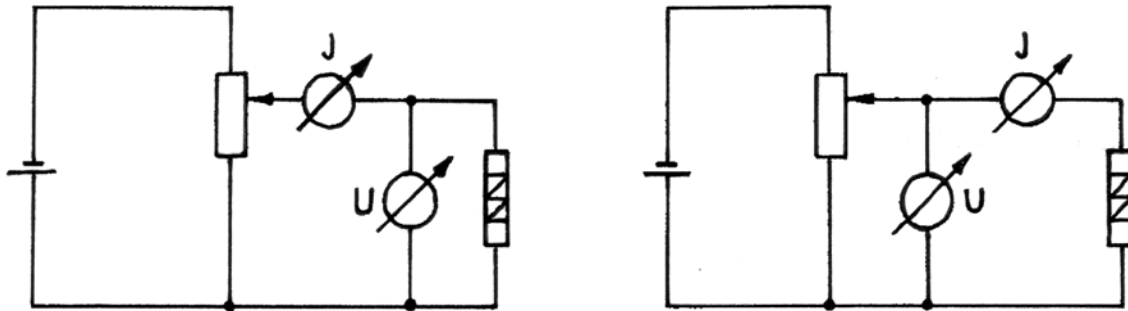

The complete current-voltage-characteristics look like this:

The systematic error is produced by the measuring instruments. Concerning the circuit diagram on the left (“Stromfehlerschaltung”), the ammeter also measures the

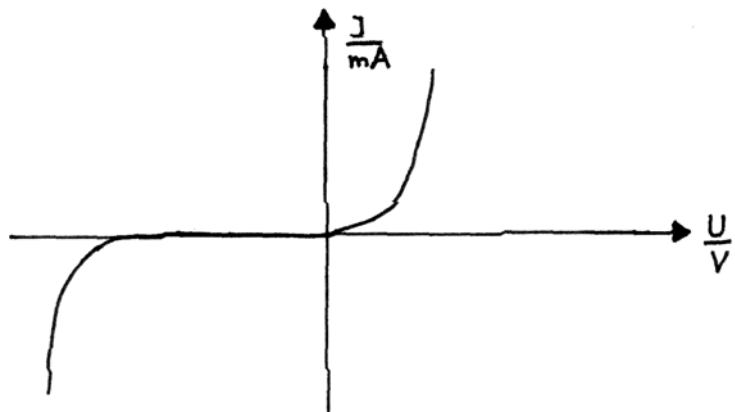

current running through the voltmeter. The current must therefore be corrected. Concerning the circuit diagram on the right (“Spannungsfehlerschaltung”) the voltmeter also measures the voltage across the ammeter. This error must also be corrected. To this end, the given internal resistances of the measuring instruments can be used. Another systematic error is produced by the uncontrolled temperature increase of the semiconductor element, whereby the electric conductivity rises.

- b) The dynamic resistance is obtained as ratio of small differences by

$$R_i = \frac{\Delta U}{\Delta I} \tag{1}$$

The dynamic resistance is different for the two directions of the current. The order of magnitude in one direction (backward direction) is $10 \Omega \pm 50\%$ and the order of magnitude in the other direction (flux direction) is $1 \Omega \pm 50\%$.

c) The complete circuit diagram contains a potentiometer and two voltmeters.

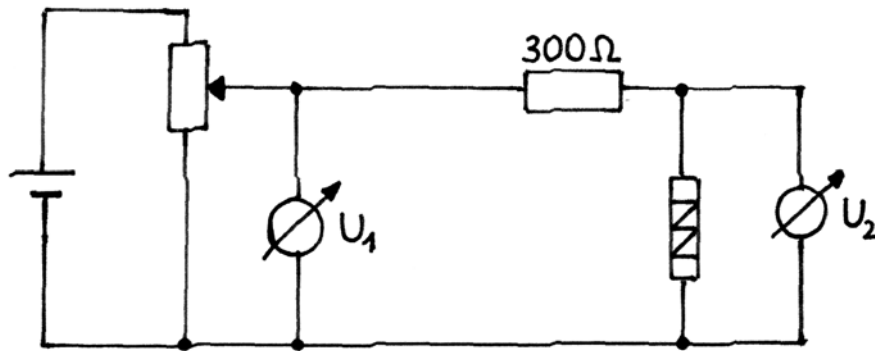

The graph of the function $U_2 = f(U_1)$ has generally the same form for both directions of the current, but the absolute values are different. By requesting that the semiconductor element has to be placed in such a way, that the output voltage U_2 is as high as possible, a backward direction should be used.

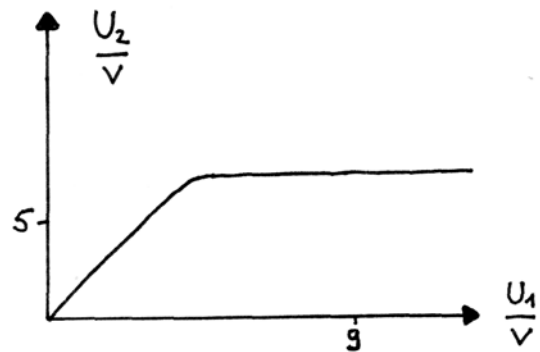

Comment: After exceeding a specific input voltage U_1 the output voltage increases only a little, because with the alteration of U_1 the current I increases (breakdown of the diode) and therefore also the voltage drop at the resistance.

d) The output voltages belonging to $U_1 = 7\text{ V}$ and $U_1 = 9\text{ V}$ are measured and their difference ΔU_2 is calculated:

$$\Delta U_2 = 0.1\text{ V} \pm 50\% \quad (2).$$

Comment: The circuit is a voltage divider circuit. Its special behaviour results from the different resistances. The resistance of the semiconductor element is much smaller than the resistance. It changes nonlinear with the voltage across the element. From $R_i \ll R_V$ follows $\Delta U_2 < \Delta U_1$ in the case of $U_1 > U_2$.

e) The semiconductor element is a Z-diode (Zener diode); also correct: diode and rectifier. The circuit diagram can be used for stabilisation of voltages.

Marking scheme

Problem 1: “Rotating rod” (10 points)

Part a	1 point
Part b – cases 1. and 2.	1 point
– forces and condition of equilibrium	1 point
– case Z downwards	2 points
– case Z upwards	2 points
– calculation of $r_{1,2}$	1 point
– case $\alpha > \beta$	1 point
– case $\alpha \leq \beta$	1 point

Problem 2: “Thick lens” (10 points)

Part a	1 point
Part b – equation (1), equation (2)	2 points
– physical restrictions, equation (3)	1 point
– discussion of different cases	2 points
– shapes of lenses	1 point
Part c – discussion and equation (4)	1 point
Part d	2 point

Problem 3: “Ions in a magnetic field” (10 points)

Part a – derivation of equations (1) and (2)	1 point
– derivation of equation (4)	1 point
Part b – characteristics properties of the particle paths	3 points
Part c – boundaries of the magnetic field for the three cases	3 points
Part d	2 points

Experimental problem: “Semiconductor element” (20 points)

Part a – considerations concerning overload, circuit diagram, experiment and measurements, complete current-voltage- -characteristics discussion of the systematic errors	6 points
Part b – equation (1) dynamic resistance for both directions correct results within $\pm 50\%$	3 points
Part c – complete circuit diagram, measurements, graph of the function $U_2 = f(U_1)$, correct comment	5 points
Part d – correct ΔU_2 within $\pm 50\%$, correct comment	3 points
Part e – Zener-diode (diode, rectifier) and stabilisation of voltages	3 points

Remarks: If the diode is destroyed two points are deducted.
 If a multimeter is destroyed five points are deducted.

Problems of the 9th International Physics Olympiads (Budapest, Hungary, 1976)

Theoretical problems

Problem 1

A hollow sphere of radius $R = 0.5$ m rotates about a vertical axis through its centre with an angular velocity of $\omega = 5$ s⁻¹. Inside the sphere a small block is moving together with the sphere at the height of $R/2$ (Fig. 6). ($g = 10$ m/s².)

- a) What should be at least the coefficient of friction to fulfill this condition?
- b) Find the minimal coefficient of friction also for the case of $\omega = 8$ s⁻¹.
- c) Investigate the problem of stability in both cases,
 - α) for a small change of the position of the block,
 - β) for a small change of the angular velocity of the sphere.

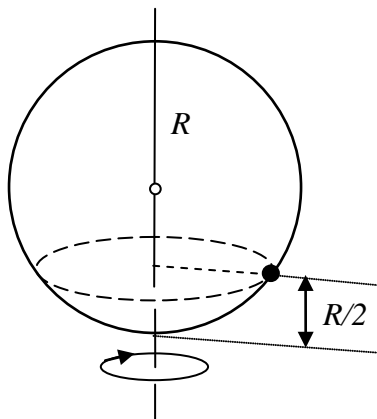

Figure 6

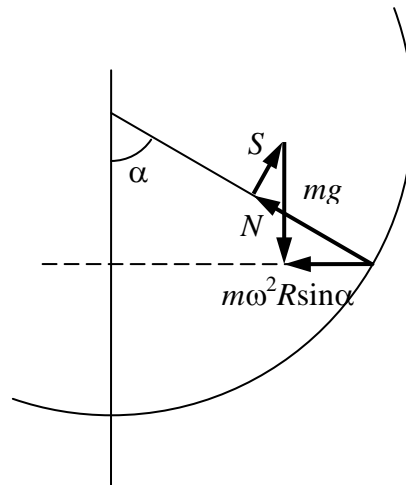

Figure 7

Solution

a) The block moves along a horizontal circle of radius $R \sin \alpha$. The net force acting on the block is pointed to the centre of this circle (Fig. 7). The vector sum of the normal force exerted by the wall N , the frictional force S and the weight mg is equal to the resultant: $m\omega^2 R \sin \alpha$.

The connections between the horizontal and vertical components:

$$m\omega^2 R \sin \alpha = N \sin \alpha - S \cos \alpha ,$$

$$mg = N \cos \alpha + S \sin \alpha .$$

The solution of the system of equations:

$$S = mg \sin \alpha \left(1 - \frac{\omega^2 R \cos \alpha}{g} \right),$$

$$N = mg \left(\cos \alpha + \frac{\omega^2 R \sin^2 \alpha}{g} \right).$$

The block does not slip down if

$$\mu_a \geq \frac{S}{N} = \sin \alpha \cdot \frac{1 - \frac{\omega^2 R \cos \alpha}{g}}{\cos \alpha + \frac{\omega^2 R \sin^2 \alpha}{g}} = \frac{3\sqrt{3}}{23} = \mathbf{0.2259}.$$

In this case there must be at least this friction to prevent slipping, i.e. sliding down.

b) If on the other hand $\frac{\omega^2 R \cos \alpha}{g} > 1$ some friction is necessary to prevent the block to slip upwards. $m\omega^2 R \sin \alpha$ must be equal to the resultant of forces S , N and mg . Condition for the minimal coefficient of friction is (Fig. 8):

$$\begin{aligned} \mu_b \geq \frac{S}{N} &= \sin \alpha \cdot \frac{\frac{\omega^2 R \cos \alpha}{g} - 1}{\cos \alpha + \frac{\omega^2 R \sin^2 \alpha}{g}} = \\ &= \frac{3\sqrt{3}}{29} = \mathbf{0.1792}. \end{aligned}$$

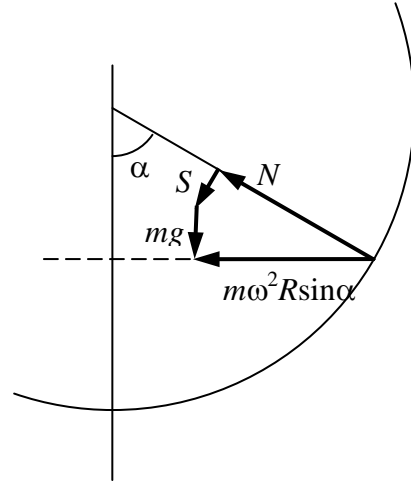
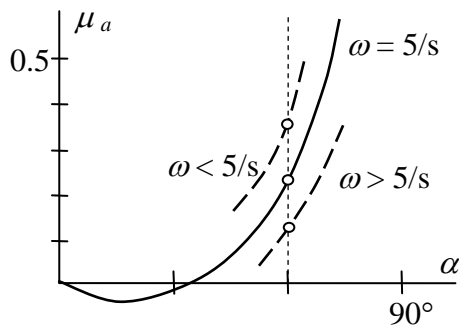
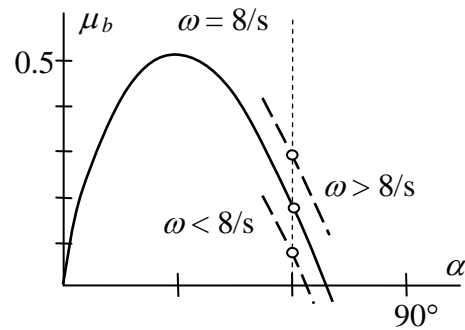

Figure 8

c) We have to investigate μ_a and μ_b as functions of α and ω in the cases a) and b) (see Fig. 9/a and 9/b):



Figure



Figure

In case a): if the block slips upwards, it comes back; if it slips down it does not return. If ω increases, the block remains in equilibrium, if ω decreases it slips downwards.

In case b): if the block slips upwards it stays there; if the block slips downwards it returns. If ω increases the block climbs upwards, if ω decreases the block remains in equilibrium.

Problem 2

The walls of a cylinder of base 1 dm^2 , the piston and the inner dividing wall are

perfect heat insulators (*Fig. 10*). The valve in the dividing wall opens if the pressure on the right side is greater than on the left side. Initially there is 12 g helium in the left side and 2 g helium in the right side. The lengths of both sides are 11.2 dm each and the temperature is 0°C. Outside we have a pressure of 100 kPa. The specific heat at constant volume is $c_v = 3.15 \text{ J/gK}$, at constant pressure it is $c_p = 5.25 \text{ J/gK}$. The piston is pushed slowly towards the dividing wall. When the valve opens we stop then continue pushing slowly until the wall is reached. Find the work done on the piston by us.

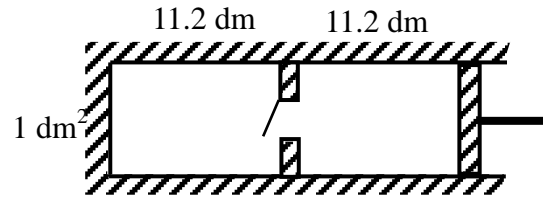

Figure 10

Solution

The volume of 4 g helium at 0°C temperature and a pressure of 100 kPa is 22.4 dm^3 (molar volume). It follows that initially the pressure on the left hand side is 600 kPa, on the right hand side 100 kPa. Therefore the valve is closed.

An adiabatic compression happens until the pressure in the right side reaches 600 kPa ($\kappa = 5/3$).

$$100 \cdot 11.2^{5/3} = 600 \cdot V^{5/3},$$

hence the volume on the right side (when the valve opens):

$$V = 3.82 \text{ dm}^3.$$

From the ideal gas equation the temperature is on the right side at this point

$$T_1 = \frac{pV}{nR} = 552 \text{ K}.$$

During this phase the whole work performed increases the internal energy of the gas:

$$W_1 = (3.15 \text{ J/gK}) \cdot (2 \text{ g}) \cdot (552 \text{ K} - 273 \text{ K}) = 1760 \text{ J}.$$

Next the valve opens, the piston is arrested. The temperature after the mixing has been completed:

$$T_2 = \frac{12 \cdot 273 + 2 \cdot 552}{14} = 313 \text{ K}.$$

During this phase there is no change in the energy, no work done on the piston.

An adiabatic compression follows from $11.2 + 3.82 = 15.02 \text{ dm}^3$ to 11.2 dm^3 :

$$313 \cdot 15.02^{2/3} = T_3 \cdot 11.2^{2/3},$$

hence

$$T_3 = 381 \text{ K}.$$

The whole work done increases the energy of the gas:

$$W_3 = (3.15 \text{ J/gK}) \cdot (14 \text{ g}) \cdot (381 \text{ K} - 313 \text{ K}) = 3000 \text{ J}.$$

The total work done:

$$W_{\text{total}} = W_1 + W_3 = 4760 \text{ J}.$$

The work done by the outside atmospheric pressure should be subtracted:

$$W_{\text{atm}} = 100 \text{ kPa} \cdot 11.2 \text{ dm}^3 = 1120 \text{ J}.$$

The work done on the piston by us:

$$W = W_{\text{total}} - W_{\text{atm}} = 3640 \text{ J.}$$

Problem 3

Somewhere in a glass sphere there is an air bubble. Describe methods how to determine the diameter of the bubble without damaging the sphere.

Solution

We can not rely on any value about the density of the glass. It is quite uncertain. The index of refraction can be determined using a light beam which does not touch the bubble. Another method consists of immersing the sphere into a liquid of same refraction index: its surface becomes invisible.

A great number of methods can be found.

We can start by determining the axis, the line which joins the centers of the sphere and the bubble. The easiest way is to use the “tumbler-over” method. If the sphere is placed on a horizontal plane the axis takes up a vertical position. The image of the bubble, seen from both directions along the axis, is a circle.

If the sphere is immersed in a liquid of same index of refraction the spherical bubble is practically inside a parallel plate (Fig. 11). Its boundaries can be determined either by a micrometer or using parallel light beams.

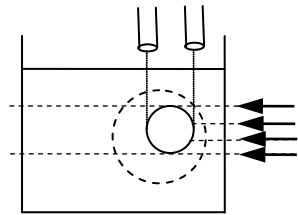

Figure 11

Along the axis we have a lens system consisting of two thick negative lenses. The diameter of the bubble can be determined by several measurements and complicated calculations.

If the index of refraction of the glass is known we can fit a plano-concave lens of same index of refraction to the sphere at the end of the axis (Fig. 12). As ABCD forms a parallel plate the diameter of the bubble can be measured using parallel light beams.

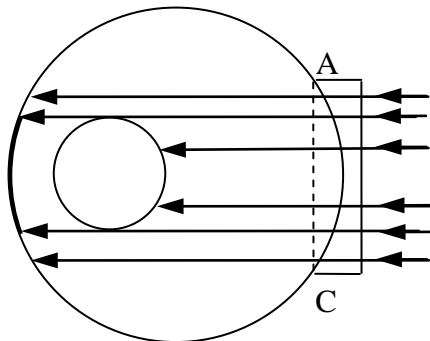

Figure 12

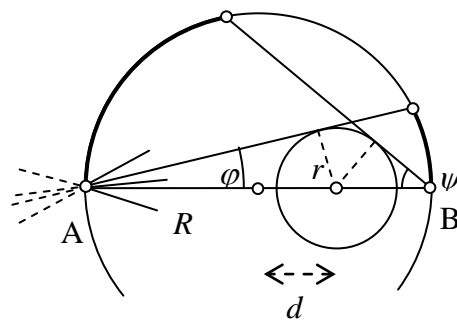

Figure 13

Focusing a light beam on point A of the surface of the sphere (Fig. 13) we get a diverging beam from point A inside the sphere. The rays strike the surface at the other side and illuminate a cap. Measuring the spherical cap we get angle φ . Angle ψ can be obtained in a similar way at point B. From

$$\sin \varphi = \frac{r}{R+d} \quad \text{and} \quad \sin \psi = \frac{r}{R-d}$$

we have

$$r = 2R \cdot \frac{\sin \psi \sin \varphi}{\sin \psi + \sin \varphi}, \quad d = R \cdot \frac{\sin \psi - \sin \varphi}{\sin \psi + \sin \varphi}.$$

The diameter of the bubble can be determined also by the help of X-rays. X-rays are not refracted by glass. They will cast shadows indicating the structure of the body, in our case the position and diameter of the bubble.

We can also determine the moment of inertia with respect to the axis and thus the diameter of the bubble.

Experimental problem

The whole text given to the students:

At the workplace there are beyond other devices a test tube with 12 V electrical heating, a liquid with known specific heat ($c_0 = 2.1 \text{ J/g}^\circ\text{C}$) and an X material with unknown thermal properties. The X material is insoluble in the liquid.

Examine the thermal properties of the X crystal material between room temperature and 70°C . Determine the thermal data of the X material. Tabulate and plot the measured data.

(You can use only the devices and materials prepared on the table. The damaged devices and the used up materials are not replaceable.)

Solution

Heating first the liquid then the liquid and the crystalline substance together two time-temperature graphs can be plotted. From the graphs specific heat, melting point and heat of fusion can be easily obtained.

Literature

- [1] W. Gorzkowski: Problems of the 1st International Physics Olympiad
Physics Competitions **5**, no2 pp6-17, 2003

- [2] R. Kunfalvi: Collection of Competition Tasks from the 1st through XVth International

Physics Olympiads 1967-1984

Roland Eötvös Physical Society in cooperation with UNESCO, Budapest, 1985

[3] A Nemzetközi Fizikai Diákolimpiák feladatai I.-XV.

Eötvös Loránd Fizikai Társulat, Középiskolai Matematikai Lapok, 1985

10th International Physics Olympiad
1977, Hradec Králové, Czechoslovakia

Problem 1. The compression ratio of a four-stroke internal combustion engine is $\varepsilon = 9.5$. The engine draws in air and gaseous fuel at a temperature 27°C at a pressure $1\text{ atm} = 100\text{ kPa}$. Compression follows an adiabatic process from point 1 to point 2, see Fig. 1. The pressure in the cylinder is doubled during the mixture ignition (2–3). The hot exhaust gas expands adiabatically to the volume V_2 pushing the piston downwards (3–4). Then the exhaust valve opens and the pressure gets back to the initial value of 1 atm . All processes in the cylinder are supposed to be ideal. The Poisson constant (i.e. the ratio of specific heats C_p/C_V) for the mixture and exhaust gas is $\kappa = 1.40$. (The compression ratio is the ratio of the volume of the cylinder when the piston is at the bottom to the volume when the piston is at the top.)

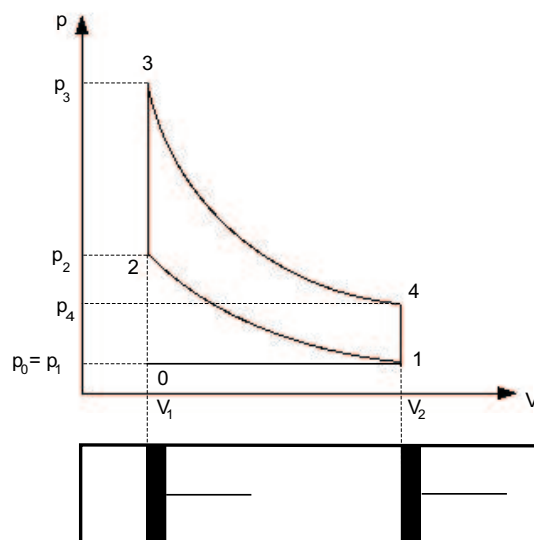

Figure 1:

- Which processes run between the points 0–1, 2–3, 4–1, 1–0?
- Determine the pressure and the temperature in the states 1, 2, 3 and 4.
- Find the thermal efficiency of the cycle.
- Discuss obtained results. Are they realistic?

Solution: a) The description of the processes between particular points is the following:

0–1 :	intake stroke	isobaric and isothermal process
1–2 :	compression of the mixture	adiabatic process
2–3 :	mixture ignition	isochoric process
3–4 :	expansion of the exhaust gas	adiabatic process
4–1 :	exhaust	isochoric process
1–0 :	exhaust	isobaric process

Let us denote the initial volume of the cylinder before induction at the point 0 by V_1 , after induction at the point 1 by V_2 and the temperatures at the particular points by T_0 , T_1 , T_2 , T_3 and T_4 .

b) The equations for particular processes are as follows.

0–1 : The fuel-air mixture is drawn into the cylinder at the temperature of $T_0 = T_1 = 300$ K and a pressure of $p_0 = p_1 = 0.10$ MPa.

1–2 : Since the compression is very fast, one can suppose the process to be adiabatic. Hence:

$$p_1 V_2^\kappa = p_2 V_1^\kappa \quad \text{and} \quad \frac{p_1 V_2}{T_1} = \frac{p_2 V_1}{T_2}.$$

From the first equation one obtains

$$p_2 = p_1 \left(\frac{V_2}{V_1} \right)^\kappa = p_1 \varepsilon^\kappa$$

and by the dividing of both equations we arrive after a straightforward calculation at

$$T_1 V_2^{\kappa-1} = T_2 V_1^{\kappa-1}, \quad T_2 = T_1 \left(\frac{V_2}{V_1} \right)^{\kappa-1} = T_1 \varepsilon^{\kappa-1}.$$

For given values $\kappa = 1.40$, $\varepsilon = 9.5$, $p_1 = 0.10$ MPa, $T_1 = 300$ K we have $p_2 = 2.34$ MPa and $T_2 = 738$ K ($t_2 = 465$ °C).

2–3 : Because the process is isochoric and $p_3 = 2p_2$ holds true, we can write

$$\frac{p_3}{p_2} = \frac{T_3}{T_2}, \quad \text{which implies} \quad T_3 = T_2 \frac{p_3}{p_2} = 2T_2.$$

Numerically, $p_3 = 4.68$ MPa, $T_3 = 1476$ K ($t_3 = 1203$ °C).

3–4 : The expansion is adiabatic, therefore

$$p_3 V_1^\kappa = p_4 V_2^\kappa, \quad \frac{p_3 V_1}{T_3} = \frac{p_4 V_2}{T_4}.$$

The first equation gives

$$p_4 = p_3 \left(\frac{V_1}{V_2} \right)^\kappa = 2p_2 \varepsilon^{-\kappa} = 2p_1$$

and by dividing we get

$$T_3 V_1^{\kappa-1} = T_4 V_2^{\kappa-1}.$$

Consequently,

$$T_4 = T_3 \varepsilon^{1-\kappa} = 2T_2 \varepsilon^{1-\kappa} = 2T_1.$$

Numerical results: $p_4 = 0.20$ MPa, $T_3 = 600$ K ($t_3 = 327$ °C).

4–1 : The process is isochoric. Denoting the temperature by T'_1 we can write

$$\frac{p_4}{p_1} = \frac{T_4}{T'_1},$$

which yields

$$T'_1 = T_4 \frac{p_1}{p_4} = \frac{T_4}{2} = T_1.$$

We have thus obtained the correct result $T'_1 = T_1$. Numerically, $p_1 = 0.10$ MPa, $T'_1 = 300$ K.

c) Thermal efficiency of the engine is defined as the proportion of the heat supplied that is converted to net work. The exhaust gas does work on the piston during the expansion 3–4, on the other hand, the work is done on the mixture during the compression 1–2. No work is done by/on the gas during the processes 2–3 and 4–1. The heat is supplied to the gas during the process 2–3.

The net work done by 1 mol of the gas is

$$W = \frac{R}{\kappa - 1}(T_1 - T_2) + \frac{R}{\kappa - 1}(T_3 - T_4) = \frac{R}{\kappa - 1}(T_1 - T_2 + T_3 - T_4)$$

and the heat supplied to the gas is

$$Q_{23} = C_V(T_3 - T_2).$$

Hence, we have for thermal efficiency

$$\eta = \frac{W}{Q_{23}} = \frac{R}{(\kappa - 1)C_V} \frac{T_1 - T_2 + T_3 - T_4}{T_3 - T_2}.$$

Since

$$\frac{R}{(\kappa - 1)C_V} = \frac{C_p - C_V}{(\kappa - 1)C_V} = \frac{\kappa - 1}{\kappa - 1} = 1,$$

we obtain

$$\eta = 1 - \frac{T_4 - T_1}{T_3 - T_2} = 1 - \frac{T_1}{T_2} = 1 - \varepsilon^{1-\kappa}.$$

Numerically, $\eta = 1 - 300/738 = 1 - 0.407$, $\eta = 59,3\%$.

d) Actually, the real pV -diagram of the cycle is smooth, without the sharp angles. Since the gas is not ideal, the real efficiency would be lower than the calculated one.

Problem 2. Dipping the frame in a soap solution, the soap forms a rectangle film of length b and height h . White light falls on the film at an angle α (measured with respect to the normal direction). The reflected light displays a green color of wavelength λ_0 .

- a) Find out if it is possible to determine the mass of the soap film using the laboratory scales which has calibration accuracy of 0.1 mg.
- b) What color does the thinnest possible soap film display being seen from the perpendicular direction? Derive the related equations.

Constants and given data: relative refractive index $n = 1.33$, the wavelength of the reflected green light $\lambda_0 = 500$ nm, $\alpha = 30^\circ$, $b = 0.020$ m, $h = 0.030$ m, density $\varrho = 1000$ kg m⁻³.

Solution: The thin layer reflects the monochromatic light of the wavelength λ in the best way, if the following equation holds true

$$2nd \cos \beta = (2k + 1) \frac{\lambda}{2}, \quad k = 0, 1, 2, \dots, \quad (1)$$

where k denotes an integer and β is the angle of refraction satisfying

$$\frac{\sin \alpha}{\sin \beta} = n.$$

Hence,

$$\cos \beta = \sqrt{1 - \sin^2 \beta} = \frac{1}{n} \sqrt{n^2 - \sin^2 \alpha}.$$

Substituting to (1) we obtain

$$2d \sqrt{n^2 - \sin^2 \alpha} = (2k + 1) \frac{\lambda}{2}. \quad (2)$$

If the white light falls on a layer, the colors of wavelengths obeying (2) are reinforced in the reflected light. If the wavelength of the reflected light is λ_0 , the thickness of the layer satisfies for the k th order interference

$$d_k = \frac{(2k + 1)\lambda_0}{4\sqrt{n^2 - \sin^2 \alpha}} = (2k + 1)d_0.$$

For given values and $k = 0$ we obtain $d_0 = 1.01 \cdot 10^{-7}$ m.

a) The mass of the soap film is $m_k = \rho_k b h d_k$. Substituting the given values, we get $m_0 = 6.06 \cdot 10^{-2}$ mg, $m_1 = 18.2 \cdot 10^{-2}$ mg, $m_2 = 30.3 \cdot 10^{-8}$ mg, etc. The mass of the thinnest film thus cannot be determined by given laboratory scales.

b) If the light falls at the angle of 30° then the film seen from the perpendicular direction cannot be colored. It would appear dark.

Problem 3. An electron gun T emits electrons accelerated by a potential difference U in a vacuum in the direction of the line a as shown in Fig. 2. The target M is placed at a distance d from the electron gun in such a way that the line segment connecting the points T and M and the line a subtend the angle α as shown in Fig. 2. Find the magnetic induction B of the uniform magnetic field

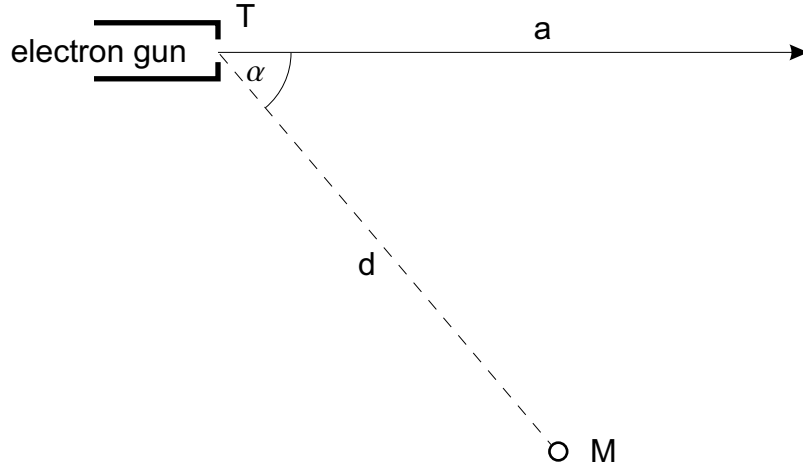

Figure 2:

- a) perpendicular to the plane determined by the line a and the point M
- b) parallel to the segment TM

in order that the electrons hit the target M . Find first the general solution and then substitute the following values: $U = 1000$ V, $e = 1.60 \cdot 10^{-19}$ C, $m_e = 9.11 \cdot 10^{-31}$ kg, $\alpha = 60^\circ$, $d = 5.0$ cm, $B < 0.030$ T.

Solution: a) If a uniform magnetic field is perpendicular to the initial direction of motion of an electron beam, the electrons will be deflected by a force that is always perpendicular to their velocity and to the magnetic field. Consequently, the beam will be deflected into a circular trajectory. The origin of the centripetal force is the Lorentz force, so

$$Bev = \frac{m_e v^2}{r}. \quad (3)$$

Geometrical considerations yield that the radius of the trajectory obeys (cf. Fig. 3).

$$r = \frac{d}{2 \sin \alpha}. \quad (4)$$

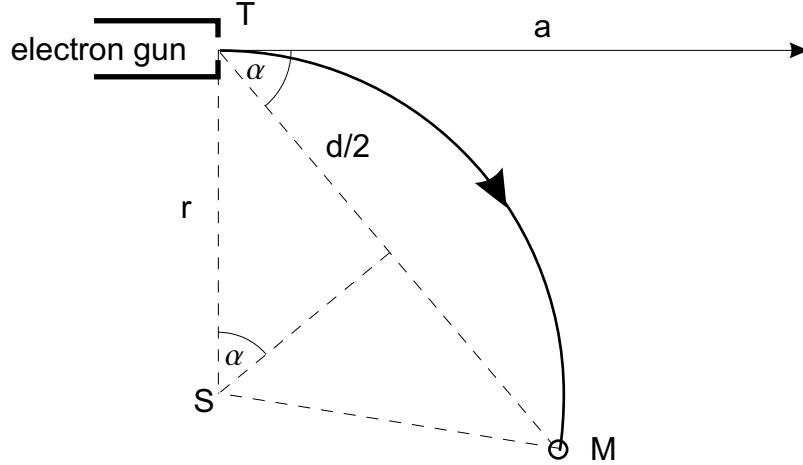

Figure 3:

The velocity of electrons can be determined from the relation between the kinetic energy of an electron and the work done on this electron by the electric field of the voltage U inside the gun,

$$\frac{1}{2}m_e v^2 = eU. \quad (5)$$

Using (3), (4) and (5) one obtains

$$B = m_e \sqrt{\frac{2eU}{m_e} \frac{2 \sin \alpha}{ed}} = 2 \sqrt{\frac{2Um_e \sin \alpha}{e} \frac{1}{d}}.$$

Substituting the given values we have $B = 3.70 \cdot 10^{-3}$ T.

b) If a uniform magnetic field is neither perpendicular nor parallel to the initial direction of motion of an electron beam, the electrons will be deflected into a helical trajectory. Namely, the motion of electrons will be composed of an uniform motion on a circle in the plane perpendicular to the magnetic field and of an uniform rectilinear motion in the direction of the magnetic field. The component \vec{v}_1 of the initial velocity \vec{v} , which is perpendicular to the magnetic field (see Fig. 4), will manifest itself at the Lorentz force and during the motion will rotate uniformly around the line parallel to the magnetic field. The component \vec{v}_2 parallel to the magnetic field will remain

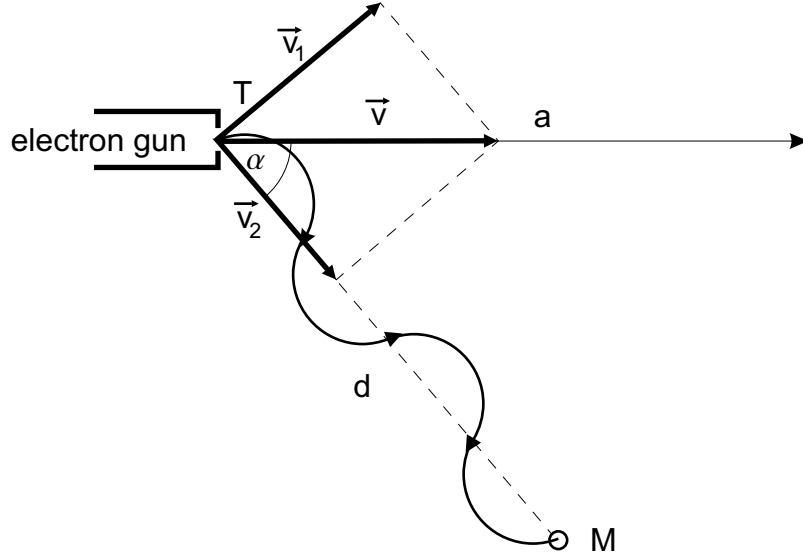

Figure 4:

constant during the motion, it will be the velocity of the uniform rectilinear motion. Magnitudes of the components of the velocity can be expressed as

$$v_1 = v \sin \alpha \quad v_2 = v \cos \alpha .$$

Denoting by N the number of screws of the helix we can write for the time of motion of the electron

$$t = \frac{d}{v_2} = \frac{d}{v \cos \alpha} = \frac{2\pi r N}{v_1} = \frac{2\pi r N}{v \sin \alpha} .$$

Hence we can calculate the radius of the circular trajectory

$$r = \frac{d \sin \alpha}{2\pi N \cos \alpha} .$$

However, the Lorentz force must be equated to the centripetal force

$$Bev \sin \alpha = \frac{m_e v^2 \sin^2 \alpha}{r} = \frac{m_e v^2 \sin^2 \alpha}{\frac{d \sin \alpha}{2\pi N \cos \alpha}} . \quad (6)$$

Consequently,

$$B = \frac{m_e v^2 \sin^2 \alpha \cdot 2\pi N \cos \alpha}{d \sin \alpha \cdot e v \sin \alpha} = \frac{2\pi N m_e v \cos \alpha}{de}.$$

The magnitude of velocity v again satisfies (5), so

$$v = \sqrt{\frac{2Ue}{m_e}}.$$

Substituting into (6) one obtains

$$B = \frac{2\pi N \cos \alpha}{d} \sqrt{\frac{2Um_e}{e}}.$$

Numerically we get $B = N \cdot 6.70 \cdot 10^{-3}$ T. If $B < 0.030$ T should hold true, we have four possibilities ($N \leq 4$). Namely,

$$B_1 = 6.70 \cdot 10^{-3} \text{ T},$$

$$B_2 = 13.4 \cdot 10^{-3} \text{ T},$$

$$B_3 = 20.1 \cdot 10^{-3} \text{ T},$$

$$B_4 = 26.8 \cdot 10^{-3} \text{ T}.$$

Problems of the XI International Olympiad, Moscow, 1979

The publication has been prepared by Prof. S. Kozel and Prof. V.Orlov

(Moscow Institute of Physics and Technology)

The XI International Olympiad in Physics for students took place in Moscow, USSR, in July 1979 on the basis of Moscow Institute of Physics and Technology (MIPT). Teams from 11 countries participated in the competition, namely Bulgaria, Finland, Germany, Hungary, Poland, Romania, Sweden, Czechoslovakia, the DDR, the SFR Yugoslavia, the USSR. The problems for the theoretical competition have been prepared by professors of MIPT (V.Belonuchkin, I.Slobodetsky, S.Kozel). The problem for the experimental competition has been worked out by O.Kabardin from the Academy of Pedagogical Sciences.

It is pity that marking schemes were not preserved.

Theoretical Problems

Problem 1.

A space rocket with mass $M=12t$ is moving around the Moon along the circular orbit at the height of $h =100$ km. The engine is activated for a short time to pass at the lunar landing orbit. The velocity of the ejected gases $u = 10^4$ m/s. The Moon radius $R_M = 1,7 \cdot 10^3$ km, the acceleration of gravity near the Moon surface $g_M = 1.7$ m/s²

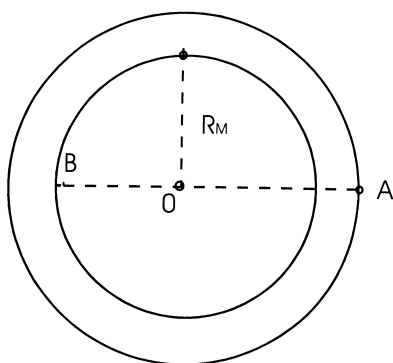

Fig.1

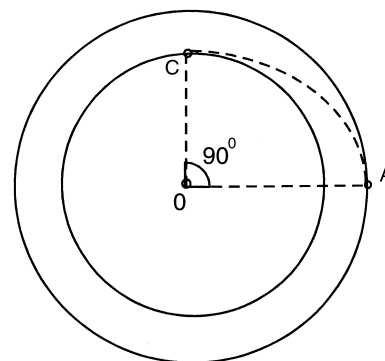

Fig.2

- 1). What amount of fuel should be spent so that when activating the braking engine at point A of the trajectory, the rocket would land on the Moon at point B (Fig.1)?
- 2). In the second scenario of landing, at point A the rocket is given an impulse directed towards the center of the Moon, to put the rocket to the orbit meeting the Moon surface at point C (Fig.2). What amount of fuel is needed in this case?

Problem 2.

Brass weights are used to weigh an aluminum-made sample on an analytical balance. The weighing is done in dry air and another time in humid air with the water vapor pressure $P_h = 2 \cdot 10^3$ Pa. The total atmospheric pressure ($P = 10^5$ Pa) and the temperature ($t = 20^\circ$ C) are the same in both cases.

What should the mass of the sample be to be able to tell the difference in the balance readings provided their sensitivity is $m_0 = 0.1$ mg ?

Aluminum density $\rho_1 = 2700$ kg/m³, brass density $\rho_2 = 8500$ kg/m³.

Problem 3

.During the Soviet-French experiment on the optical location of the Moon the light pulse of a ruby laser ($\lambda = 0,69 \mu\text{m}$) was directed to the Moon's surface by the telescope with a diameter of the mirror $D = 2,6$ m. The reflector on the Moon's surface reflected the light backward as an ideal mirror with the diameter $d = 20$ cm. The reflected light was then collected by the same telescope and focused at the photodetector.

- 1) What must the accuracy to direct the telescope optical axis be in this experiment?
- 2) What part of emitted laser energy can be detected after reflection on the Moon, if we neglect the light losses in the Earth's atmosphere?
- 3) Can we see a reflected light pulse with naked eye if the energy of single laser pulse $E = 1$ J and the threshold sensitivity of eye is equal $n = 100$ light quantum?
- 4) Suppose the Moon's surface reflects $\alpha = 10\%$ of the incident light in the spatial angle 2π steradian, estimate the advantage of a using reflector.

The distance from the Earth to the Moon is $L = 380000$ km. The diameter of pupil of the eye is $d_p = 5$ mm. Plank constant is $h = 6.6 \cdot 10^{-34}$ J·s.

Experimental Problem

Define the electrical circuit scheme in a "black box" and determine the parameters of its elements.
List of instruments: A DC source with tension 4.5 V, an AC source with 50 Hz frequency and output voltage up to 30 V, two multimeters for measuring AC/DC current and voltage, variable resistor, connection wires.

Solution of Problems of the XI International Olympiad, Moscow, 1979
Solution of Theoretical Problems

Problem 1.

- 1) During the rocket moving along the circular orbit its centripetal acceleration is created by moon gravity force:

$$G \frac{MM_M}{R^2} = \frac{Mv_0^2}{R},$$

where $R = R_M + h$ is the primary orbit radius, v_0 -the rocket velocity on the circular orbit:

$$v_0 = \sqrt{G \frac{M_M}{R}}$$

Since $g_M = G \frac{M_M}{R_M^2}$ it yields

$$v_0 = \sqrt{\frac{g_M R_M^2}{R}} = R_M \sqrt{\frac{g_M}{R_M + h}} \quad (1)$$

The rocket velocity will remain perpendicular to the radius-vector OA after the braking engine sends tangential momentum to the rocket (Fig.1). The rocket should then move along the elliptical trajectory with the focus in the Moon's center.

Denoting the rocket velocity at points A and B as v_A and v_B we can write the equations for energy and momentum conservation as follows:

$$\frac{Mv_A^2}{2} - G \frac{MM_M}{R} = \frac{Mv_B^2}{2} - G \frac{MM_M}{R_M} \quad (2)$$

$$Mv_A R = Mv_B R_M \quad (3)$$

Solving equations (2) and (3) jointly we find

$$v_A = \sqrt{2G \frac{M_M R_M}{R(R + R_M)}}$$

Taking (1) into account, we get

$$v_A = v_0 \sqrt{\frac{2R_M}{R + R_M}}.$$

Thus the rocket velocity change Δv at point A must be

$$\Delta v = v_0 - v_A = v_0 \left(1 - \sqrt{\frac{2R_M}{R + R_M}} \right) = v_0 \left(1 - \sqrt{\frac{2R_M}{2R_M + h}} \right) = 24 \text{ m/s}.$$

Since the engine switches on for a short time the momentum conservation law in the system “rocket-fuel” can be written in the form

$$(M - m_1)\Delta v = m_1 u$$

where m_1 is the burnt fuel mass.

This yields

$$m_1 = \frac{\Delta v}{u + \Delta v}$$

Allow for $\Delta v \ll u$ we find

$$m_1 \approx \frac{\Delta v}{u} M = 29 \text{ kg}$$

2) In the second case the vector \vec{v}_2 is directed perpendicular to the vector \vec{v}_0 thus giving

$$\vec{v}_A = \vec{v}_0 + \Delta \vec{v}_2, \quad v_A = \sqrt{v_0^2 + \Delta v_2^2}.$$

Based on the energy conservation law in this case the equation can be written as

$$\frac{M(v_0^2 + \Delta v_2^2)}{2} - \frac{GMM_M}{R} = \frac{Mv_C^2}{2} - \frac{GMM_M}{R_M} \quad (4)$$

and from the momentum conservation law

$$Mv_0 R = Mv_C R_M. \quad (5)$$

Solving equations (4) and (5) jointly and taking into account (1) we find

$$\Delta v_2 = \sqrt{g_M \frac{(R - R_M)^2}{R}} = h \sqrt{\frac{g_M}{R_M + h}} \approx 97 \text{ m/s}.$$

Using the momentum conservation law we obtain

$$m_2 = \frac{\Delta v_2}{u} M \approx 116 \text{ kg}.$$

Problem 2.

A sample and weights are affected by the Archimede's buoyancy force of either dry or humid air in the first and second cases, respectively. The difference in the scale indication ΔF is determined by the change of difference of these forces.

The difference of Archimede's buoyancy forces in dry air:

$$\Delta F_1 = \Delta V \rho_a' g$$

Whereas in humid air it is:

$$\Delta F_2 = \Delta V \rho_a'' g$$

where ΔV - the difference in volumes between the sample and the weights, and ρ_a' and ρ_a'' - densities of dry and humid air, respectively.

Then the difference in the scale indications ΔF could be written as follows:

$$\Delta F = \Delta F_1 - \Delta F_2 = \Delta V g (\rho_a' - \rho_a'') \quad (1)$$

According to the problem conditions this difference should be distinguished, i.e. $\Delta F \geq m_0 g$ or $\Delta V g (\rho_a' - \rho_a'') \geq m_0$, wherefrom

$$\Delta V \geq \frac{m_0}{\rho_a' - \rho_a''} . \quad (2)$$

The difference in volumes between the aluminum sample and brass weights can be found from the equation

$$\Delta V = \frac{m}{\rho_1} - \frac{m}{\rho_2} = m \left(\frac{\rho_2 - \rho_1}{\rho_1 \rho_2} \right) , \quad (3)$$

where m is the sought mass of the sample. From expressions (2) and (3) we obtain

$$m = \Delta V \left(\frac{\rho_1 \rho_2}{\rho_2 - \rho_1} \right) \geq \frac{m_0}{\rho_a' - \rho_a''} \left(\frac{\rho_1 \rho_2}{\rho_2 - \rho_1} \right) . \quad (4)$$

To find the mass m of the sample one has to determine the difference $(\rho_a' - \rho_a'')$.

With the general pressure being equal, in the second case, some part of dry air is replaced by vapor:

$$\rho_a' - \rho_a'' = \frac{\Delta m_a}{V} - \frac{\Delta m_v}{V} .$$

Changes of mass of air Δm_a and vapor Δm_v can be found from the ideal-gas equation of state

$$\Delta m_a = \frac{P_a V M_a}{RT} , \quad \Delta m_v = \frac{P_v V M_v}{RT} ,$$

wherefrom we obtain

$$\rho_a' - \rho_a'' = \frac{P_a (M_a - M_v)}{RT} . \quad (5)$$

From equations (4) and (5) we obtain

$$m \geq \frac{m_0 RT}{P_a (M_a - M_v)} \left(\frac{\rho_1 \rho_2}{\rho_2 - \rho_1} \right) . \quad (6)$$

The substitution of numerical values gives the answer: $m \geq 0.0432 \text{ kg} \approx 43 \text{ g}$.

Note. When we wrote down expression (3), we considered the sample mass be equal to the weights' mass, at the same time allowing for a small error.

One may choose another way of solving this problem. Let us calculate the change of Archimede's force by the change of the air average molar mass.

In dry air the condition of the balance between the sample and weights could be written down in the form of

$$\left(\rho_1 - \frac{M_a P}{RT} \right) V_1 = \left(\rho_2 - \frac{M_a P}{RT} \right) V_2 . \quad (7)$$

In humid air its molar mass is equal to

$$M = M_a \frac{P_a}{P} + M_v \frac{P - P_a}{P}, \quad (8)$$

whereas the condition of finding the scale error could be written in the form

$$\left(\rho_1 - \frac{M_a P}{RT} \right) V_1 - \left(\rho_2 - \frac{M_a P}{RT} \right) V_2 \geq m_0 . \quad (9)$$

From expressions (7)–(9) one can get a more precise answer

$$m \geq \frac{m_0 RT \rho_1 \rho_2 - M_a P_a}{(M_a - M_v)(\rho_2 - \rho_1) P_a} . \quad (10)$$

Since $M_a P_a \ll m_0 \rho_1 \rho_2 RT$, then both expressions (6) and (10) lead practically to the same quantitative result, i.e. $m \geq 43 \text{ g}$.

Problem 3.

1) The beam divergence angle $\delta\varphi$ caused by diffraction defines the accuracy of the telescope optical axis installation:

$$\delta\varphi \approx \lambda/D \approx 2.6 \cdot 10^{-7} \text{ rad.} \approx 0.05'' .$$

2) The part K_1 of the light energy of a laser, directed to a reflector, may be found by the ratio of the area of S_1 reflector ($S_1 = \pi d^2/4$) versus the area S_2 of the light spot on the Moon ($S_2 = \pi r^2$, where $r = L \delta\varphi \approx L\lambda/D$, L – the distance from the Earth to the Moon)

$$K_1 = \frac{S_1}{S_2} = \frac{d^2}{(2r)^2} = \frac{d^2 D^2}{4\lambda^2 L^2}$$

The reflected light beam diverges as well and forms a light spot with the radius R on the Earth's surface:

$$R = \lambda L/d, \quad \text{as} \quad r \ll R$$

That's why the part K_2 of the reflected energy, which got into the telescope, makes

$$K_2 = \frac{D^2}{(2R)^2} = \frac{D^2 d^2}{4\lambda^2 L^2}$$

The part K_0 of the laser energy, that got into the telescope after having been reflected by the reflector on the Moon, equals

$$K_0 = K_1 K_2 = \left(\frac{dD}{2\lambda L} \right)^4 \approx 10^{-12}$$

3) The pupil of a naked eye receives as less a part of the light flux compared to a telescope, as the area of the pupil S_e is less than the area of the telescope mirror S_t :

$$K_e = K_0 \frac{S_e}{S_t} = K_0 \frac{d_e^2}{D^2} \approx 3.7 \cdot 10^{-18}.$$

So the number of photons N getting into the pupil of the eye is equal

$$N = \frac{E}{h\nu} K_e = 12.$$

Since $N < n$, one can not perceive the reflected pulse with a naked eye.

4) In the absence of a reflector $\alpha = 10\%$ of the laser energy, that got onto the Moon, are dispersed by the lunar surface within a solid angle $\Omega_1 = 2\pi$ steradian.

The solid angle in which one can see the telescope mirror from the Moon, constitutes

$$\Omega_2 = S_t / L^2 = \pi D^2 / 4L^2$$

That is why the part K of the energy gets into the telescope and it is equal

$$K = \alpha \frac{\Omega_2}{\Omega_1} = \alpha \frac{D^2}{8L^2} \approx 0.5 \cdot 10^{-18}$$

Thus, the gain β , which is obtained through the use of the reflector is equal

$$\beta = K_0 / K \approx 2 \cdot 10^6$$

Note. The result obtained is only evaluative as the light flux is unevenly distributed inside the angle of diffraction.

Solution of Experimental Problem.

A transformer is built-in in a “black box”. The black box has 4 terminals. To be able to determine the equivalent circuit and the parameters of its elements one may first carry out measurements of the direct current. The most expedient is to mount the circuit according to the layout in Fig.3 and to build volt-ampere characteristics for various terminals of the “box”. This enables one to make sure rightway that there were no e.m.f. sources in the “box” (the plot $I=f(U)$ goes through the origin of the coordinates), no diodes (the current strength does not depend on the polarity of the current’s external source), by the inclination angle of the plot one may define the resistances between different terminals of the “box”. The tests allowed for some estimations of values R_{1-2} and R_{3-4} . The ammeter did not register any current between the other terminals. This means that between these terminals there might be some other resistors with resistances larger than R_L :

$$R_L = \frac{U_{\max}}{I_{\min}} = \frac{4,5\text{V}}{2 \cdot 10^{-6}\text{A}} = 2.25 \cdot 10^6 \text{ ohm}$$

where I_{\min}
of the
which the
have

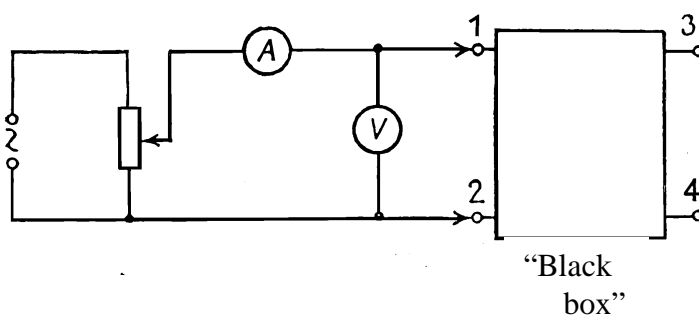

- the minimum value
strength of the current
instrument would

Fig.3

registered. Probably there might be some capacitors between terminals 1-3, 1-4, 2-3, 2-4 (Fig.4).

Then, one can carry out analogous measurements of an alternative current. The taken volt-ampere characteristics enabled one to find full resistances on the alternative current of sections 1-2 and 3-4: Z_1 and Z_2 and to compare them to the values R_1 and R_2 . It turned out, that $Z_1 > R_1$ and $Z_2 > R_2$.

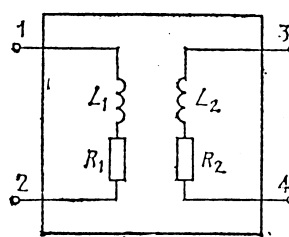
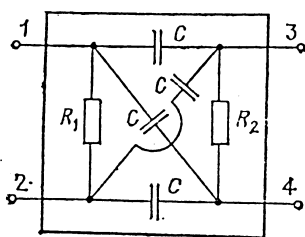

Fig.4

Fig.5

This fact allows one to conclude that in the “black box” the coils are connected to terminals 1-2 and 3-4 (Fig.5). Inductances of coils L_1 and L_2 can be determined by the formulas

$$L_1 = \frac{\sqrt{Z_1^2 - R_1^2}}{2\pi\nu}, \quad L_2 = \frac{\sqrt{Z_2^2 - R_2^2}}{2\pi\nu}.$$

After that the dependences $Z = f(I)$, $L = f(I)$ are to be investigated. The character of the found dependences enabled one to draw a conclusion about the presence of ferromagnetic cores in the coils. Judging by the results of the measurements on the alternative current one could identify the upper limit of capacitance of the capacitors which could be placed between terminals 1-3, 1-4, 2-3, 2-4:

$$C_{\max} = \frac{I_{\min}}{2\pi\nu U_{\max}} = \frac{5 \cdot 10^{-6} \text{ A}}{2 \cdot 3.14 \cdot 50 \text{ s}^{-1} \cdot 3 \text{ V}} = 5 \cdot 10^{-9} \text{ F} = 5 \text{ nF}$$

Then one could check the availability of inductive coupling between circuits 1-2 and 3-4. The plot of dependence of voltage U_{3-4} versus voltage U_{1-2} (Fig. 6) allows one to find both the transformation coefficient

$$K = \frac{U_{1-2}}{U_{3-4}} = \frac{1}{2}$$

and the maximum operational voltages on coils L_1 and L_2 , when the transformation

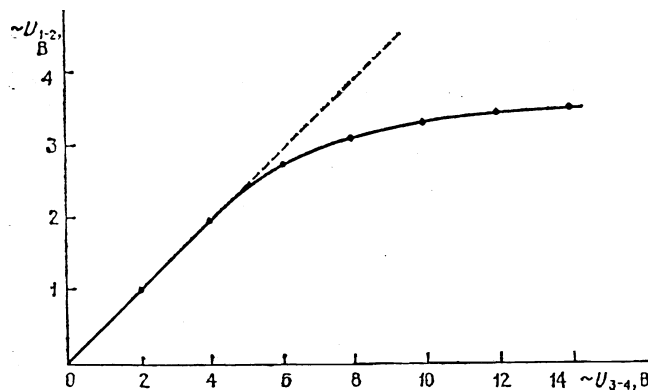

Fig.6

coefficient has not changed yet, i.e. before saturation of the core.

$$U_{1-2(\max)} = 2.5 \text{ V}, \quad U_{3-4(\max)} = 5 \text{ V}.$$

One could build either plot $K(U_{1-2})$ or $K(U_{3-4})$ (Fig. 7).

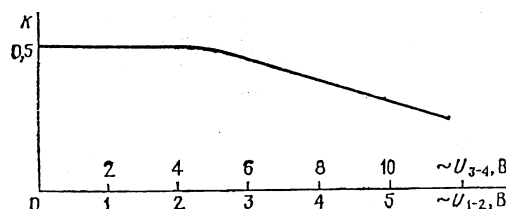

Fig.7

Note: It was also possible to define the “box” circuit after tests of the direct current. To do that one had to find the presence of induction coupling between terminals 1-2 and 3-4, that is the appearance of e.m.f. of induction in circuit 3-4, when closing and breaking circuits 1-2 and vice-versa. When comparing the direction of the pointer’s rejection of the voltmeters connected to terminals 1-2 and 3-4 one could identify directions of the transformer’s windings.

Acknowledgement

The authors would like to express their thanks and gratitude to Professor Waldemar Gorzkowski and Professor Ivo Volf for supplying the materials for the XI IphO in the Polish, Hungarian and Czech languages that have been of great help to the authors in their work at the problems of the Olympiad.

References:

1. O.Kabardin, V.Orlov, International Physics Olympiads for Pupuls, Nauka, Moskva 1985.
2. W.Gorzkowski, A.Kotlicki, Olimpiady Fizyczne XXVII i XXVIII, WsiP, Warszawa 1983
3. R.Kunfalvi, Collection of Competition Tasks from the 1 trough XV International Physics Olympiads, 1867-1984, Roland Eotvos Physical Society an UNESCO, Budapest 1985
4. V.Urumov, Megjunadodni Olimpijadi po Fisika, Prosvento Delo, Skopje 1999
5. D.Klvanec, I.Volf, Mezinarodni Fysikalni Olympiady, MaFy, Hradec Kralowe 1993

XII International Physics Olympiad

Varna, Bulgaria, July 1981

*The problems and the solutions are adapted by Miroslav Abrashev
University of Sofia, Faculty of Physics, 5 James Bourchier Blvd., 1164 Sofia, Bulgaria*

Reference: O. F. Kabardin, V. A. Orlov, in “International Physics Olympiads for High School Students”, ed. V. G. Razumovski, Moscow, Nauka, 1985. (In Russian).

Theoretical Problem 1

A static container of mass M and cylindrical shape is placed in vacuum. One of its ends is closed. A fixed piston of mass m and negligible width separates the volume of the container into two equal parts. The closed part contains n moles of monoatomic perfect gas with molar mass M_0 and temperature T . After releasing of the piston, it leaves the container without friction. After that the gas also leaves the container. What is the final velocity of the container?

The gas constant is R . The momentum of the gas up to the leaving of the piston can be neglected. There is no heat exchange between the gas, container and the piston. The change of the temperature of the gas, when it leaves the container, can be neglected. Do not account for the gravitation of the Earth.

Theoretical Problem 2

An electric lamp of resistance $R_0 = 2 \Omega$ working at nominal voltage $U_0 = 4.5 \text{ V}$ is connected to accumulator of electromotive force $E = 6 \text{ V}$ and negligible internal resistance.

1. The nominal voltage of the lamp is ensured as the lamp is connected potentiometrically to the accumulator using a rheostat with resistance R . What should be the resistance R and what is the maximal electric current I_{max} , flowing in the rheostat, if the efficiency of the system must not be smaller than $\eta_0 = 0.6$?

2. What is the maximal possible efficiency η of the system and how the lamp can be connected to the rheostat in this case?

Theoretical Problem 3

A detector of radiowaves in a radioastronomical observatory is placed on the sea beach at height $h = 2 \text{ m}$ above the sea level. After the rise of a star, radiating electromagnetic waves of wavelength $\lambda = 21 \text{ cm}$, above the horizon the detector registers series of alternating maxima and minima. The registered signal is proportional to the intensity of the detected waves. The detector registers waves with electric vector, vibrating in a direction parallel to the sea surface.

1. Determine the angle between the star and the horizon in the moment when the detector registers maxima and minima (in general form).

2. Does the signal decrease or increase just after the rise of the star?

3. Determine the signal ratio of the first maximum to the next minimum. At reflection of the electromagnetic wave on the water surface, the ratio of the intensities of the electric field of the reflected (E_r) and incident (E_i) wave follows the low:

$$\frac{E_r}{E_i} = \frac{n - \cos \varphi}{n + \cos \varphi},$$

where n is the refraction index and φ is the incident angle of the wave. For the surface “air-water” for $\lambda = 21$ cm, the refraction index $n = 9$.

4. Does the ratio of the intensities of consecutive maxima and minima increase or decrease with rising of the star?

Assume that the sea surface is flat.

Solution of the Theoretical Problem 1

Up to the moment when the piston leaves the container, the system can be considered as a closed one. It follows from the laws of the conservation of the momentum and the energy:

$$(M + nM_0)v_1 - mu = 0 \quad (1)$$

$$\frac{(M + nM_0)v_1^2}{2} + \frac{mu^2}{2} = \Delta U, \quad (2)$$

where v_1 – velocity of the container when the piston leaves it, u – velocity of the piston in the same moment, ΔU – the change of the internal energy of the gas. The gas is perfect and monoatomic, therefore

$$\Delta U = \frac{3}{2}nR\Delta T = \frac{3}{2}nR(T - T_f); \quad (3)$$

T_f - the temperature of the gas in the moment when the piston leaves the container. This temperature can be determined by the law of the adiabatic process:

$$pV^\gamma = \text{const.}$$

Using the perfect gas equation $pV = nRT$, one obtains

$$TV^{\gamma-1} = \text{const.}, \quad TV^{\gamma-1} = T_f V_f^{\gamma-1}$$

Using the relation $V_f = 2V$, and the fact that the adiabatic coefficient for one-atomic gas is

$\gamma = \frac{c_p}{c_v} = \frac{\frac{5}{2}R}{\frac{3}{2}R} = \frac{5}{3}$, the result for final temperature is:

$$T_f = T \left(\frac{V}{V_f} \right)^{\gamma-1} = \frac{T}{2^{\frac{2}{3}}} = T 2^{-\frac{2}{3}} \quad (4)$$

Solving the equations (1) – (4) we obtain

$$v_1 = \sqrt{3(1 - 2^{-\frac{2}{3}}) \frac{mnRT}{(nM_0 + M)(m + nM_0 + M)}} \quad (5)$$

If the gas mass nM_0 is much smaller than the masses of the container M and the piston m , then the equation (5) is simplified to:

$$v_1 = \sqrt{3(1 - 2^{-\frac{2}{3}}) \frac{mnRT}{M(m + M)}} \quad (5')$$

When the piston leaves the container, the velocity of the container additionally increases to value v_2 due to the hits of the atoms in the bottom of the container. Each atom gives the container momentum:

$$p = 2m_A \overline{\Delta v_x},$$

where m_A – mass of the atom; $m_A = \frac{M_0}{N_A}$, and $\overline{v_x}$ can be obtained by the averaged quadratic velocity of the atoms $\overline{v^2}$ as follows:

$\overline{v_x^2} + \overline{v_y^2} + \overline{v_z^2} = \overline{v^2}$, and $\overline{v_x^2} = \overline{v_y^2} = \overline{v_z^2}$, therefore $\overline{v_x} = \sqrt{\frac{\overline{v^2}}{3}}$. It appears that due to the elastic impact of one atom the container receives averaged momentum

$$p = 2 \frac{M_0}{N_A} \sqrt{\frac{\overline{v^2}}{3}}$$

All calculations are done assuming that the thermal velocities of the atoms are much larger than the velocity of the container and that the movement is described using system connected with the container.

Have in mind that only half of the atoms hit the bottom of the container, the total momentum received by the container is

$$p_t = \frac{1}{2} n N_A p = n M_0 \sqrt{\frac{\overline{v^2}}{3}} \quad (6)$$

and additional increase of the velocity of the container is

$$v_2 = \frac{p_t}{M} = n \frac{M_0}{M} \sqrt{\frac{\overline{v^2}}{3}}. \quad (7)$$

Using the formula for the averaged quadratic velocity

$$\sqrt{\overline{v^2}} = \sqrt{\frac{3RT_f}{M_0}}$$

as well eq. (4) for the temperature T_f , the final result for v_2 is

$$v_2 = 2^{-1/3} \frac{n \sqrt{M_0 RT}}{M}. \quad (8)$$

Therefore the final velocity of the container is

$$\begin{aligned} v = v_1 + v_2 &= \sqrt{3(1 - 2^{-2/3})} \frac{mnRT}{(nM_0 + M)(m + nM_0 + M)} + 2^{-1/3} \frac{n \sqrt{M_0 RT}}{M} \approx \\ &\approx \sqrt{3(1 - 2^{-2/3})} \frac{mnRT}{M(m + M)} + 2^{-1/3} \frac{n \sqrt{M_0 RT}}{M}. \end{aligned} \quad (9)$$

Solution of the Theoretical Problem 2

1) The voltage U_0 of the lamp of resistance R_0 is adjusted using the rheostat of resistance R . Using the Kirchhoff laws one obtains:

$$I = \frac{U_0}{R} + \frac{U_0}{R - R_x}, \quad (1)$$

where $R - R_x$ is the resistance of the part of the rheostat, parallel connected to the lamp, R_x is the resistance of the rest part,

$$U_0 = E - IR_x \quad (2)$$

The efficiency η of such a circuit is

$$\eta = \frac{P_{lamp}}{P_{accum.}} = \frac{U_0^2 / r}{IE} = \frac{U_0^2}{RIE}. \quad (3)$$

From eq. (3) it is seen that the maximal current, flowing in the rheostat, is determined by the minimal value of the efficiency:

$$I_{max} = \frac{U_0^2}{RE\eta_{min}} = \frac{U_0^2}{RE\eta_0}. \quad (4)$$

The dependence of the resistance of the rheostat R on the efficiency η can be determined replacing the value for the current I , obtained by the eq. (3), $I = \frac{U_0^2}{RE\eta}$, in the eqs. (1) and (2):

$$\frac{U_0}{RE\eta} = \frac{1}{R_0} + \frac{1}{R - R_x}, \quad (5)$$

$$R_x = (E - U_0) \frac{RE\eta}{U_0^2}. \quad (6)$$

Then

$$R = R_0 \eta \frac{E^2}{U_0^2} \frac{1 + \eta(1 - \frac{E}{U_0})}{1 - \frac{E}{U_0} \eta}. \quad (7)$$

To answer the questions, the dependence $R(\eta)$ must be investigated. By this reason we find the first derivative R'_η :

$$R'_\eta \propto \left(\frac{\eta + \eta^2(1 - \frac{E}{U_0})}{1 - \frac{E}{U_0} \eta} \right)'$$

$$\propto 1 + 2\eta(1 - \frac{E}{U_0})(1 - \frac{E}{U_0} \eta) + \left[\eta + \eta^2(1 - \frac{E}{U_0}) \right] \frac{E}{U_0} = \eta(2 - \frac{E}{U_0} \eta)(1 - \frac{E}{U_0}) + 1.$$

$\eta < 1$, therefore the above obtained derivative is positive and the function $R(\eta)$ is increasing. It means that the efficiency will be minimal when the rheostat resistance is minimal. Then

$$R \geq R_{min} = R_0 \eta_0 \frac{E^2}{U_0^2} \frac{1 + \eta_0(1 - \frac{E}{U_0})}{1 - \frac{E}{U_0} \eta_0} \approx 8.53 \Omega.$$

The maximal current I_{max} can be calculated using eq. (4). The result is: $I_{max} \approx 660$ mA.

2) As the function $R(\eta)$ is increasing one, $\eta \rightarrow \eta_{\max}$, when $R \rightarrow \infty$. In this case the total current I will be minimal and equal to $\frac{U_0}{R}$. Therefore the maximal efficiency is

$$\eta_{\max} = \frac{U_0}{E} = 0.75$$

This case can be realized connecting the rheostat in the circuit using only two of its three plugs. The used part of the rheostat is R_1 :

$$R_1 = \frac{E - U_0}{I_0} = \frac{E - U_0}{U_0} R_0 \approx 0.67 \Omega.$$

Solution of the Theoretical Problem 3

1) The signal, registered by the detector A, is result of the interference of two rays: the ray 1, incident directly from the star and the ray 2, reflected from the sea surface (see the figure).

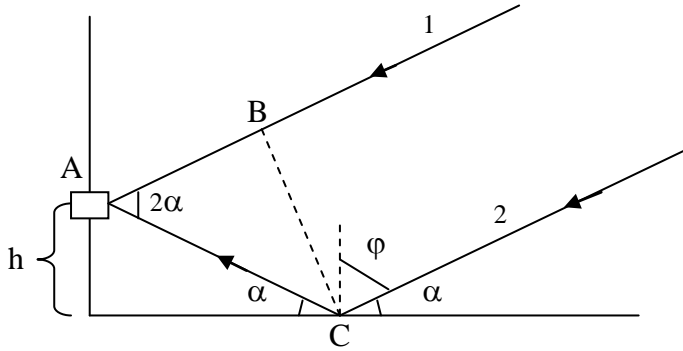

The phase of the second ray is shifted by π due to the reflection by a medium of larger refractive index. Therefore, the phase difference between the two rays is:

$$\begin{aligned} \Delta &= AC + \frac{\lambda}{2} - AB = \frac{h}{\sin \alpha} + \frac{\lambda}{2} - \left(\frac{h}{\sin \alpha} \right) \cos(2\alpha) = \\ &= \frac{\lambda}{2} + \frac{h}{\sin \alpha} [1 - \cos(2\alpha)] = \frac{\lambda}{2} + 2h \sin \alpha \end{aligned} \quad (1)$$

The condition for an interference maximum is:

$$\begin{aligned} \frac{\lambda}{2} + 2h \sin \alpha_{\max} &= k\lambda, \text{ or} \\ \sin \alpha_{\max} &= \left(k - \frac{1}{2} \right) \frac{\lambda}{2h} = (2k - 1) \frac{\lambda}{4h}, \end{aligned} \quad (2)$$

where $k = 1, 2, 3, \dots, 19$. (the difference of the optical paths cannot exceed $2h$, therefore k cannot exceed 19).

The condition for an interference minimum is:

$$\begin{aligned} \frac{\lambda}{2} + 2h \sin \alpha_{\max} &= (2k + 1) \frac{\lambda}{2}, \text{ or} \\ \sin \alpha_{\min} &= \frac{k\lambda}{2h} \end{aligned} \quad (3)$$

where $k = 1, 2, 3, \dots, 19$.

2) Just after the rise of the star the angular height α is zero, therefore the condition for an interference minimum is satisfied. By this reason just after the rise of the star, the signal will increase.

3) If the condition for an interference maximum is satisfied, the intensity of the electric field is a sum of the intensities of the direct ray E_i and the reflected ray E_r , respectively: $E_{\max} = E_i + E_r$.

$$\text{Because } E_r = E_i \frac{n - \cos \varphi}{n + \cos \varphi}, \text{ then } E_{\max} = E_i \left(1 + \frac{n - \cos \varphi_{\max}}{n + \cos \varphi_{\max}} \right).$$

From the figure it is seen that $\varphi_{\max} = \frac{\pi}{2} - \alpha_{\max}$, we obtain

$$E_{\max} = E_i \left(1 + \frac{n - \sin \alpha_{\max}}{n + \sin \alpha_{\max}} \right) = E_i \frac{2n}{n + \sin(2\alpha_{\max})}. \quad (4)$$

At the interference minimum, the resulting intensity is:

$$E_{\min} = E_i - E_r = E_i \frac{2 \sin \alpha_{\min}}{n + \sin \alpha_{\min}}. \quad (5)$$

The intensity I of the signal is proportional to the square of the intensity of the electric field E , therefore the ratio of the intensities of the consecutive maxima and minima is:

$$\frac{I_{\max}}{I_{\min}} = \left(\frac{E_{\max}}{E_{\min}} \right)^2 = \frac{n^2}{\sin^2 \alpha_{\min}} \frac{(n + \sin \alpha_{\min})^2}{(n + \sin \alpha_{\max})^2}. \quad (6)$$

Using the eqs. (2) and (3), the eq. (6) can be transformed into the following form:

$$\frac{I_{\max}}{I_{\min}} = \frac{4n^2 h^2}{k^2 \lambda^2} \left[\frac{n + k \frac{\lambda}{2h}}{n + (2k-1) \frac{\lambda}{4h}} \right]^2. \quad (7)$$

Using this general formula, we can determine the ratio for the first maximum ($k=1$) and the next minimum:

$$\frac{I_{\max}}{I_{\min}} = \frac{4n^2 h^2}{\lambda^2} \left(\frac{n + \frac{\lambda}{2h}}{n + \frac{\lambda}{4h}} \right)^2 = 3.10^4$$

4) Using that $n \gg \frac{\lambda}{2h}$, from the eq. (7) follows :

$$\frac{I_{\max}}{I_{\min}} \approx \frac{4n^2 h^2}{k^2 \lambda^2}.$$

So, with the rising of the star the ratio of the intensities of the consecutive maxima and minima decreases.

XII International Physics Olympiad

Varna, Bulgaria, July 1981

*The problems and the solutions are adapted by Miroslav Abrashev
University of Sofia, Faculty of Physics, 5 James Bourchier Blvd., 1164 Sofia, Bulgaria*

Reference: O. F. Kabardin, V. A. Orlov, in "International Physics Olympiads for High School Students", ed. V. G. Razumovski, Moscow, Nauka, 1985. (In Russian).

The Experimental Problem

Materials and Instruments: elastic rubber cord (the length of free cord is $l_0 = 150$ mm), vertically hanged up to a stand, set of weights from 10 g to 100 g, pan for the weights with mass 5 g, chronometer, ruler, millimeter (scaled) paper.

Note: The Earth Acceleration is $g = 10 \text{ m/s}^2$. The mass of the rubber cord can be neglected.

Make the following study:

1. Load the rubber cord with weights in the range 15 g to 105 g. Put the data obtained into a table. Make a graph (using suitable scale) with the experimentally obtained dependence of the prolongation of the cord on the stress force F .

2. Using the experimental results, obtained in p.1, calculate and put into a table the volume of the cord as a function of the loading in the range 35 g to 95 g. Do the calculations consequently for each two adjacent values of the loading in this range. Write down the formulas you have used for the calculations. Make an analytical proposition about the dependence of the volume on the loading.

Assume that Young's modulus is constant: $E = 2 \cdot 10^6$ Pa. Take in mind that the Hooke's law is only approximately valid and the deviations from it can be up to 10%.

3. Determine the volume of the rubber cord, using the chronometer, at mass of the weight equal to 60 g. Write the formulas used.

Solution of the Experimental Problem

1. The measurements of the cord length l_n at different loadings m_n must be at least 10. The results are shown in Table I.

Table 1.

m_n , kg	$F_n = m_n \cdot g$, N	l_n , mm	$\Delta l_n = l_n - l_0$, mm
0.005	0.05	153	3
0.015	0.15	158	8
0.025	0.25	164	14
0.035	0.35	172	22
0.045	0.45	181	31
0.055	0.55	191	41
0.065	0.65	202	53
0.075	0.75	215	65
0.085	0.85	228	78
0.095	0.95	243	93

0.105	10.5	261	111
-------	------	-----	-----

The obtained dependence of the prolongation of the cord on the stress force F can be drawn on graph. It is shown in Fig. 1.

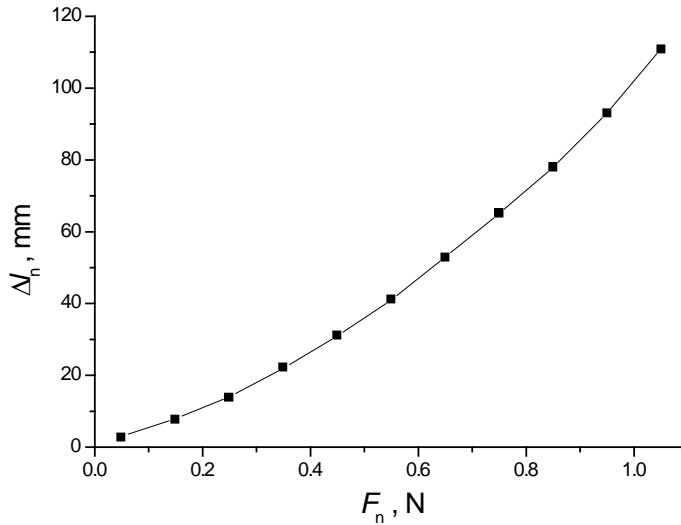

Fig.1

2. For the calculations of the volume the Hooke's law can be used for each measurement:

$$\frac{\Delta l'_n}{l_n} = \frac{1}{E} \frac{\Delta F_n}{S_n},$$

therefore

$$S_n = \frac{l_n \Delta F_n}{E \Delta l'_n},$$

where $\Delta l'_n = l_n - l_{n-1}$, $\Delta F_n = \Delta m g$. (Using the Hooke's law in the form $\frac{\Delta l_n}{l_n} = \frac{1}{E} \frac{F_n}{S_n}$ leads to larger error, because the value of the Δl_n is of the same order as l_n).

As the value of the S_n is determined, it is easy to calculate the volume V_n at each value of F_n :

$$V_n = S_n l_n = \frac{l_n^2 \Delta F_n}{E \Delta l'_n}.$$

Using the data from Table 1, all calculations can be presented in Table 2:

$\Delta m_n = m_n - m_{n-1}, \text{kg}$	$\Delta F_n = \Delta m_n g, \text{N}$	l_n, m	$\Delta l_n = l_n - l_{n-1}, \text{m}$	$S_n = \frac{l_n \Delta F_n}{E \Delta l'_n}, \text{m}^2$	$V_n = l_n S_n, \text{m}^3$
0.035 – 0.025	0.1	0.172	0.008	$1,07 \cdot 10^{-6}$	$184 \cdot 10^{-9}$
0.045 – 0.035	0.1	0.181	0.009	$1,01 \cdot 10^{-6}$	$183 \cdot 10^{-9}$
0.055 – 0.045	0.1	0.191	0.010	$0,95 \cdot 10^{-6}$	$182 \cdot 10^{-9}$
0.065 – 0.055	0.1	0.203	0.012	$0,92 \cdot 10^{-6}$	$187 \cdot 10^{-9}$
0.075 – 0.065	0.1	0.215	0.012	$0,89 \cdot 10^{-6}$	$191 \cdot 10^{-9}$
0.085 – 0.075	0.1	0.228	0.013	$0,88 \cdot 10^{-6}$	$200 \cdot 10^{-9}$

0.095 – 0.085	0.1	0.243	0.015	$0,81 \cdot 10^{-6}$	$196 \cdot 10^{-9}$
0.105 – 0.095	0.1	0.261	0.018	$0,72 \cdot 10^{-6}$	$188 \cdot 10^{-9}$

The results show that the relative deviation from the averaged value of the calculated values of the volume is:

$$\varepsilon = \frac{\Delta V_{n,aver.} \cdot 100\%}{V_{aver.}} \approx \frac{5,3 \cdot 10^{-9}}{189 \cdot 10^{-9}} \cdot 100\% \approx 2.8\%$$

Therefore, the conclusion is that the volume of the rubber cord upon stretching is constant:

$$V_n = const.$$

3. The volume of the rubber cord at fixed loading can be determined investigating the small vibrations of the cord. The reason for these vibrations is the elastic force:

$$F = ES \frac{\Delta l}{l}$$

Using the second law of Newton:

$$-ES \frac{\Delta l}{l} = m \frac{d^2(\Delta l)}{dt^2},$$

the period of the vibrations can be determined:

$$T = 2\pi \sqrt{\frac{ml}{ES}}.$$

Then

$$S = \frac{(2\pi)^2 ml}{ET^2},$$

and the volume of the cord is equal to:

$$V = Sl = \frac{4\pi^2 ml^2}{ET^2}$$

The measurement of the period gives: $T = t/n = 5.25s / 10 = 0.52$ s at used mass $m = 0.065$ kg. The result for the volume $V \approx 195 \cdot 10^{-9} \text{ m}^3$, in agreement with the results obtained in part 2.

Problems of the 13th International Physics Olympiad

(Malente, 1982)

Gunter Lind & Gunnar Friege ¹

Leibniz-Institute for Science Education (IPN) at the University of Kiel, Germany

Abstract

The 13th International Physics Olympiad took place in 1982 in the Federal Republic of Germany. This article contains the competition problems, their solutions and a grading scheme.

Introduction

In 1982 the Federal Republic of Germany was the first host of the Physics Olympiad outside the so-called Eastern bloc. The 13th International Physics Olympiad took place in Malente, Schleswig-Holstein. The competition was funded by the German Federal Ministry of Science and Education. The organisational guidelines were laid down by the work group “Olympiads for pupils” of the conference of ministers of education of the German federal states. The Institute for Science Education (IPN) at the University of Kiel was responsible for the realisation of the event. A commission of professors, whose chairman was appointed by the German Physical Society, were concerned with the formulation of the competition problems. All other members of the commission came from physics department of the university of Kiel or from the college of education at Kiel.

The problems as usual covered different fields of classical physics. In 1982 the pupils had to deal with three theoretical and two experimental problems, whereas at the previous Olympiads only one experimental task was given. However, it seemed to be reasonable to put more stress on experimental work. The degree of difficulty was well balanced. One of the theoretical problems could be considered as quite simple (problem 3: “hot-air balloon”). Another theoretical problem (problem 1: “fluorescent lamp”) had a mean degree of difficulty and the distribution of the points was a normal distribution with only a few

¹ Contact: Leibniz-Institute for Science Education (IPN) at the University of Kiel
Olshausenstrasse 62, 24098 Kiel, Germany
ipho@ipn.uni-kiel.de

excellent and only a few unsatisfying solutions. The third problem (problem 2: “oscillation coat hanger”) turned out to be the most difficult problem. This problem was generally considered as quite interesting because different ways of solving were possible. About one third of the pupils did not find an adequate start to the problem, but nearly one third of the pupils was able to solve the substantial part of the problem. That means, this problem polarized between the pupils. The two experimental tasks were quite different in respect of the input for the experimental setup and the time required for dealing with the problems, whereas they were quite similar in the degree of difficulty. Both required demandingly theoretical considerations and experimental skills. Both experimental problems turned out to be rather difficult. The tasks were composed in a way that on the one hand almost every pupil had the possibility to come to certain partial results and that there were some difficulties on the other hand which could only be solved by very few pupils. The difficulty in the second experimental problem (problem5: “motion of a rolling cylinder”) was the explanation of the experimental results, which were initially quite surprising. The difficulty in the other task (problem 4: “lens experiment”) was the revealing of an observation method with a high accuracy (parallax). The five hours provided for solving the two experimental problems were slightly too short. According to that, in both experiments only a few pupils came up with excellent solutions. In problem 5 nobody got the full points.

The problems presented here are based on the original German and English versions of the competition problems. The solutions are complete but in some parts condensed to the essentials. Almost all of the original hand-made figures are published here.

Theoretical Problems

Problem 1: Fluorescent lamp

An alternating voltage of 50 Hz frequency is applied to the fluorescent lamp shown in the accompanying circuit diagram.

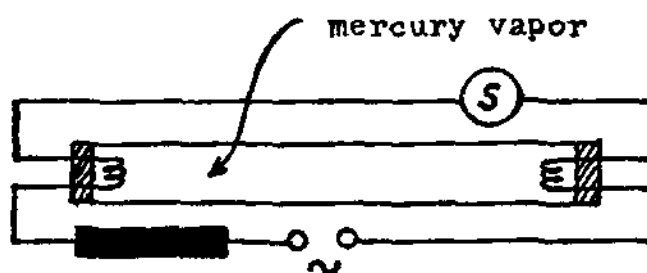

The following quantities are measured:

overall voltage (main voltage)	$U = 228.5 \text{ V}$
electric current	$I = 0.6 \text{ A}$
partial voltage across the fluorescent lamp	$U' = 84 \text{ V}$
ohmic resistance of the series reactor	$R_d = 26.3 \Omega$

The fluorescent lamp itself may be considered as an ohmic resistor in the calculations.

- What is the inductance L of the series reactor?
- What is the phase shift φ between voltage and current?
- What is the active power P_w transformed by the apparatus?
- Apart from limiting the current the series reactor has another important function. Name and explain this function!

Hint: The starter  includes a contact which closes shortly after switching on the lamp, opens up again and stays open.

- In a diagram with a quantitative time scale sketch the time sequence of the luminous flux emitted by the lamp.
- Why has the lamp to be ignited only once although the applied alternating voltage goes through zero in regular intervals?
- According to the statement of the manufacturer, for a fluorescent lamp of the described type a capacitor of about $4.7 \mu\text{F}$ can be switched in series with the series reactor. How does this affect the operation of the lamp and to what intent is this possibility provided for?
- Examine both halves of the displayed demonstrator lamp with the added spectroscope. Explain the differences between the two spectra. You may walk up to the lamp and you may keep the spectroscope as a souvenir.

Solution of problem 1:

a) The total resistance of the apparatus is $Z = \frac{228.5 \text{ V}}{0.6 \text{ A}} = 380.8 \Omega$,

the ohmic resistance of the tube is $R_R = \frac{84 \text{ V}}{0.6 \text{ A}} = 140 \Omega$.

Hence the total ohmic resistance is $R = 140 \Omega + 26.3 \Omega = 166.3 \Omega$.

Therefore the inductance of the series reactor is: $\omega \cdot L = \sqrt{Z^2 - R^2} = 342.6 \Omega$.

This yields $L = \frac{342.6 \Omega}{100 \pi \text{ s}^{-1}} = 1.09 \text{ H}$.

b) The impedance angle is obtained from $\tan \varphi = \frac{\omega \cdot L}{R} = \frac{342.6 \Omega}{166.3 \Omega} = 2.06$.

Thus $\varphi = 64.1^\circ$.

c) The active power can be calculated in different ways:

1) $P_w = U \cdot I \cdot \cos \varphi = 228.5 \text{ V} \cdot 0.6 \text{ A} \cdot \cos 64.1^\circ = 59.88 \text{ W}$

2) $P_w = R \cdot I^2 = 166.3 \Omega \cdot (0.6 \text{ A})^2 = 59.87 \text{ W}$

d) By opening the contact in the starter a high induction voltage is produced across the series reactor (provided the contact does not open exactly the same moment, when the current goes through zero). This voltage is sufficient to ignite the lamp. The main voltage itself, however, is smaller than the ignition voltage of the fluorescent tube.

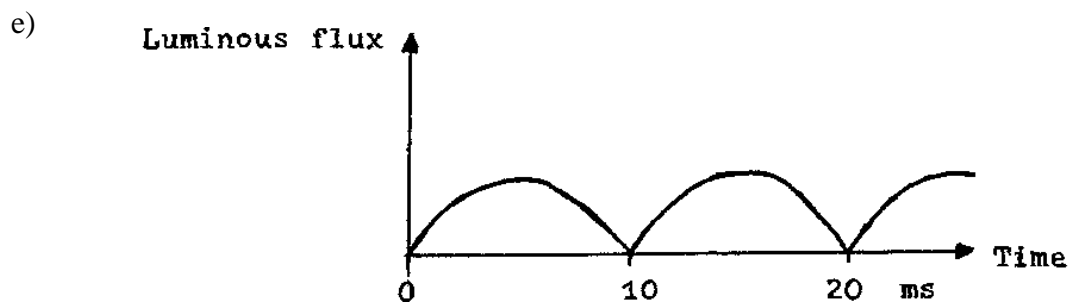

f) The recombination time of the ions and electrons in the gaseous discharge is sufficiently large.

g) The capacitive resistance of a capacitor of 4.7 μF is

$$\frac{1}{\omega \cdot C} = (100 \cdot \pi \cdot 4.7 \cdot 10^{-6})^{-1} \Omega = 677.3 \Omega.$$

The two reactances subtract and there remains a reactance of 334.7 Ω acting as a capacitor.

The total resistance of the arrangement is now

$$Z' = \sqrt{(334.7)^2 + (166.3)^2} \Omega = 373.7 \Omega,$$

which is very close to the total resistance without capacitor, if you assume the capacitor to be loss-free (cf. a)). Thus the lamp has the same operating qualities, ignites the same way, and a difference is found only in the impedance angle φ' , which is opposite to the angle φ calculated in b):

$$\tan \varphi' = \frac{\omega \cdot L - (\omega \cdot C)^{-1}}{R} = -\frac{334.7}{166.3} = -2.01$$

$$\varphi' = -63.6^\circ.$$

Such additional capacitors are used for compensation of reactive currents in buildings with a high number of fluorescent lamps, frequently they are prescribed by the electricity supply companies. That is, a high portion of reactive current is unwelcome, because the power generators have to be laid out much bigger than would be really necessary and transport losses also have to be added which are not paid for by the customer, if pure active current meters are used.

h) The uncoated part of the demonstrator lamp reveals the line spectrum of mercury, the coated part shows the same line spectrum over a continuous background. The continuous spectrum results from the ultraviolet part of the mercury light, which is absorbed by the fluorescence and re-emitted with smaller frequency (energy loss of the photons) or larger wavelength respectively.

Problem 2: Oscillating coat hanger

A (suitably made) wire coat hanger can perform small amplitude oscillations in the plane of the figure around the equilibrium positions shown. In positions a) and b) the long side is

horizontal. The other two sides have equal length. The period of oscillation is the same in all cases.

What is the location of the center of mass, and how long is the period?

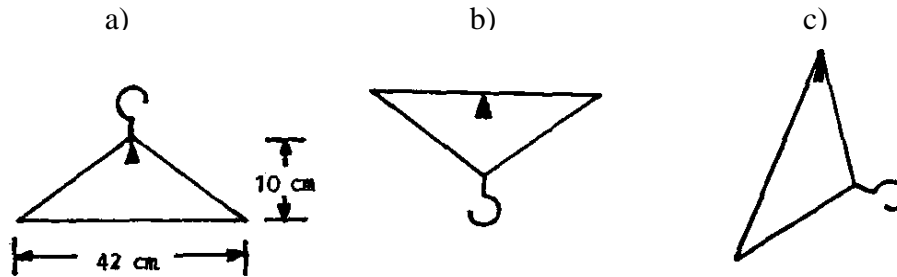

The figure does not contain any information beyond the dimensions given. Nothing is known, e.g., concerning the detailed distribution of mass.

Solution of problem 2

First method:

The motions of a rigid body in a plane correspond to the motion of two equal point masses connected by a rigid massless rod. The moment of inertia then determines their distance.

Because of the equilibrium position a) the center of mass is on the perpendicular bisector of the long side of the coat hanger. If one imagines the equivalent masses and the supporting point P being arranged in a straight line in each case, only two positions of P yield the same period of oscillation (see sketch). One can understand this by considering the limiting cases: 1. both supporting points

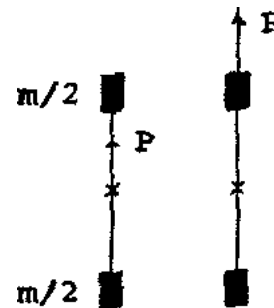

in the upper mass and 2. one point in the center of mass and the other infinitely high above. Between these extremes the period of oscillation grows continuously. The supporting point placed in the corner of the long side c) has the largest distance from the center of mass, and therefore this point lies outside the two point masses. The two other supporting points a), b) then have to be placed symmetrically to the center of mass between the two point masses, i.e., the center of mass bisects the perpendicular bisector. One knows of the reversible pendulum that for every supporting point of the physical pendulum it generally has a second supporting point of the pendulum rotated by 180° , with the same period of oscillation but at a different distance from the center of mass. The

section between the two supporting points equals the length of the corresponding mathematical pendulum. Therefore the period of oscillation is obtained through the corresponding length of the pendulum $s_b + s_c$, where $s_b = 5 \text{ cm}$ and $s_c = \sqrt{5^2 + 21^2} \text{ cm}$, to be $T = 1.03 \text{ s}$.

Second method:

Let s denote the distance between the supporting point and the center of mass, m the mass itself and θ the moment of inertia referring to the supporting point. Then we have the period of oscillation T :

$$T = 2\pi \sqrt{\frac{\theta}{m \cdot g \cdot s}}, \quad (1)$$

where g is the acceleration of gravity, $g = 9.81 \text{ m/s}^2$. Here θ can be obtained from the moment of inertia θ_0 related to the center of mass:

$$\theta = \theta_0 + m \cdot s^2 \quad (2)$$

Because of the symmetrical position in case a) the center of mass is to be found on the perpendicular bisection above the long side. Now (1) and (2) yield

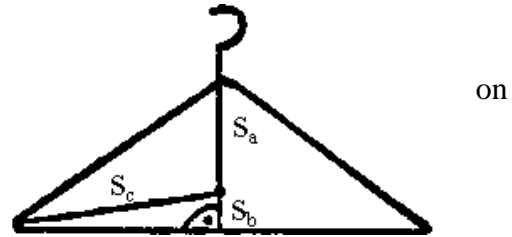

$$\theta_0 + m \cdot s^2 = \left(\frac{T}{2 \cdot \pi}\right)^2 \cdot m \cdot g \cdot s \quad \text{for } s = s_a, s_b \text{ and } s_c. \quad (3)$$

because all periods of oscillation are the same. This quadratic equation has only two different solutions at most. Therefore at least two of the three distances are equal. Because of $s_c > 21 \text{ cm} > s_a + s_b$, only s_a and s_b can equal each other. Thus we have

$$s_a = 5 \text{ cm} \quad (4)$$

The moment of inertia θ_0 is eliminated through (3):

$$m \cdot (s_c^2 - s_a^2) = \left(\frac{T}{2 \cdot \pi}\right)^2 \cdot m \cdot g \cdot (s_c - s_a)$$

and we have
$$T = 2 \cdot \pi \sqrt{\frac{s_c + s_a}{g}} \quad (5)$$

with the numerical value $T = 1.03 \text{ s}$,

which has been rounded off after two decimals because of the accuracy of g .

Third method:

This solution is identical to the previous one up to equation (2).

From (1) and (2) we generally have for equal periods of oscillation $T_1 = T_2$:

$$\frac{\theta_0 + m \cdot s_1^2}{m \cdot g \cdot s_1} = \frac{\theta_0 + m \cdot s_2^2}{m \cdot g \cdot s_2}$$

and therefore $s_2 \cdot (\theta_0 + m \cdot s_1^2) = s_1 \cdot (\theta_0 + m \cdot s_2^2)$

$$\text{or} \quad (s_2 - s_1) \cdot (\theta_0 - m \cdot s_1 \cdot s_2) = 0 \quad (6)$$

The solution of (6) includes two possibilities: $s_1 = s_2$ or $s_1 \cdot s_2 = \frac{\theta_0}{m}$

Let $2 \cdot a$ be the length of the long side and b the height of the coat hanger. Because of

$T_b = T_c$ we then have either $s_b = s_c$ or $s_b \cdot s_c = \frac{\theta_0}{m}$, where $s_c = \sqrt{s_b^2 + a^2}$,

$$\text{which excludes the first possibility. Thus} \quad s_b \cdot s_c = \frac{\theta_0}{m}. \quad (7)$$

For $T_a = T_b$ the case $s_a \cdot s_b = \frac{\theta_0}{m}$ is excluded because of eq. (7), for we have

$$s_a \cdot s_b < s_c \cdot s_b = \frac{\theta_0}{m}.$$

Hence $s_a = s_b = \frac{1}{2}b$, $s_c = \sqrt{\frac{1}{4}b^2 + a^2}$

$$\text{and} \quad T = 2 \cdot \pi \sqrt{\frac{\frac{\theta_0}{m} + s_b^2}{g \cdot s_b}} = 2\pi \sqrt{\frac{s_b \cdot s_c + s_b^2}{g \cdot s_b}}$$

The numerical calculation yields the value $T = 1.03 \text{ s}$.

Problem 3: Hot-air-balloon

Consider a hot-air balloon with fixed volume $V_B = 1.1 \text{ m}^3$. The mass of the balloon-envelope, whose volume is to be neglected in comparison to V_B , is $m_H = 0.187 \text{ kg}$.

The balloon shall be started, where the external air temperature is $\vartheta_1 = 20 \text{ }^\circ\text{C}$ and the normal external air pressure is $p_0 = 1.013 \cdot 10^5 \text{ Pa}$. Under these conditions the density of air is $\rho_1 = 1.2 \text{ kg/m}^3$.

- a) What temperature ϑ_2 must the warmed air inside the balloon have to make the balloon just float?
- b) First the balloon is held fast to the ground and the internal air is heated to a steady-state temperature of $\vartheta_3 = 110 \text{ }^\circ\text{C}$. The balloon is fastened with a rope.

Calculate the force on the rope.

- c) Consider the balloon being tied up at the bottom (the density of the internal air stays constant). With a steady-state temperature $\vartheta_3 = 110 \text{ }^\circ\text{C}$ of the internal air the balloon rises in an isothermal atmosphere of $20 \text{ }^\circ\text{C}$ and a ground pressure of $p_0 = 1.013 \cdot 10^5 \text{ Pa}$. Which height h can be gained by the balloon under these conditions?
- d) At the height h the balloon (question c)) is pulled out of its equilibrium position by 10 m and then is released again.

Find out by qualitative reasoning what kind of motion it is going to perform!

Solution of problem 3:

- a) Floating condition:

The total mass of the balloon, consisting of the mass of the envelope m_H and the mass of the air quantity of temperature ϑ_2 must equal the mass of the displaced air quantity with temperature $\vartheta_1 = 20 \text{ }^\circ\text{C}$.

$$V_B \cdot \rho_2 + m_H = V_B \cdot \rho_1$$

$$\rho_2 = \rho_1 - \frac{m_H}{V_B} \tag{1}$$

Then the temperature may be obtained from

$$\frac{\rho_1}{\rho_2} = \frac{T_2}{T_1},$$

$$T_2 = \frac{\rho_1}{\rho_2} \cdot T_1 = 341.53 \text{ K} = 68.38 \text{ }^\circ\text{C} \quad (2)$$

- b) The force F_B acting on the rope is the difference between the buoyant force F_A and the weight force F_G :

$$F_B = V_B \cdot \rho_1 \cdot g - (V_B \cdot \rho_3 + m_H) \cdot g \quad (3)$$

It follows with $\rho_3 \cdot T_3 = \rho_1 \cdot T_1$

$$F_B = V_B \cdot \rho_1 \cdot g \cdot \left(1 - \frac{T_1}{T_3}\right) - m_H \cdot g = 1,21 \text{ N} \quad (4)$$

- c) The balloon rises to the height h , where the density of the external air ρ_h has the same value as the effective density ρ_{eff} , which is evaluated from the mass of the air of temperature $\vartheta_3 = 110 \text{ }^\circ\text{C}$ (inside the balloon) and the mass of the envelope m_H :

$$\rho_{\text{eff}} = \frac{m_2}{V_B} = \frac{\rho_3 \cdot V_B + m_H}{V_B} = \rho_h = \rho_1 \cdot e^{-\frac{\rho_1 \cdot g \cdot h}{\rho_0}} \quad (5)$$

Resolving eq. (5) for h gives: $h = \frac{p_0}{\rho_1 \cdot g} \cdot \ln \frac{\rho_1}{\rho_{\text{eff}}} = 843 \text{ m} \quad (6).$

- d) For *small* height differences (10 m in comparison to 843 m) the exponential pressure drop (or density drop respectively) with height can be approximated by a linear function of height. Therefore the driving force is proportional to the elongation out of the equilibrium position.

This is the condition in which harmonic oscillations result, which of course are damped by the air resistance.

Experimental Problems

Problem 4: Lens experiment

The apparatus consists of a symmetric biconvex lens, a plane mirror, water, a meter stick, an optical object (pencil), a supporting base and a right angle clamp. Only these parts may be used in the experiment.

- Determine the focal length of the lens with a maximum error of $\pm 1\%$.
- Determine the index of refraction of the glass from which the lens is made.

The index of refraction of water is $n_w = 1.33$. The focal length of a thin lens is given by

$$\frac{1}{f} = (n-1) \cdot \left(\frac{1}{r_1} - \frac{1}{r_2} \right),$$

where n is the index of refraction of the lens material and r_1 and r_2 are the curvature radii of the refracting surfaces. For a symmetric biconvex lens we have $r_1 = -r_2 = r$, for a symmetric biconcave lens $r_1 = -r_2 = -r$.

Solution of problem 4:

- For the determination of f_L , place the lens on the mirror and with the clamp fix the pencil to the supporting base. Lens and mirror are then moved around until the vertically downward looking eye sees the pencil and its image side by side.

In order to have object and image in focus at the same time, they must be placed at an equal distance to the eye.

In this case object distance and image distance are the same and the magnification factor is 1.

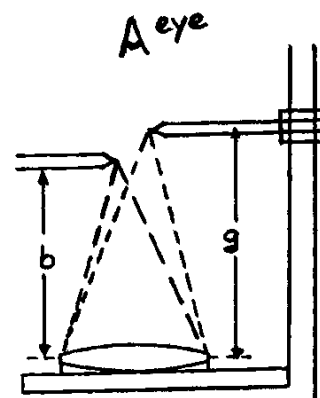

It may be proved quite accurately, whether magnification 1 has in fact been obtained, if one concentrates on parallax shifts between object and image when moving the eye: only when the distances are equal do the pencil-tips point at each other all the time.

The light rays pass the lens twice because they are reflected by the mirror. Therefore the optical mapping under consideration corresponds to a mapping with two lenses placed directly one after another:

$$\frac{1}{g} + \frac{1}{b} = \frac{1}{f}, \quad \text{where} \quad \frac{1}{f} = \frac{1}{f_L} + \frac{1}{f_L}$$

i.e. the effective focal length f is just half the focal length of the lens. Thus we find for magnification 1:

$$g = b \quad \text{and} \quad \frac{2}{g} = \frac{2}{f_L} \quad \text{i.e.} \quad f_L = g.$$

A different derivation of $f_L = g = b$: For a mapping of magnification 1 the light rays emerging from a point on the optical axis are reflected into themselves. Therefore these rays have to hit the mirror at right angle and so the object distance g equals the focal length f_L of the lens in this case.

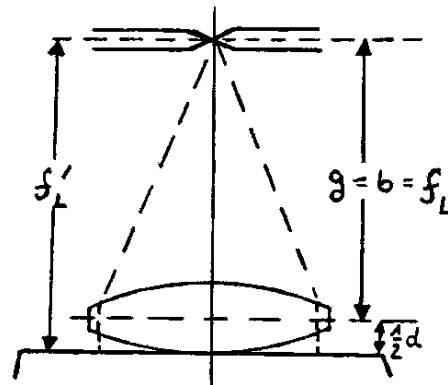

The distance between pencil point and mirror has to be determined with an accuracy, which enables one to state f_L with a maximum error of $\pm 1\%$. This is accomplished either by averaging several measurements or by stating an uncertainty interval, which is found through the appearance of parallax.

Half the thickness of the lens has to be subtracted from the distance between pencil-point and mirror.

$$f_L = f_L' - \frac{1}{2}d, \quad d = 3.0 \pm 0.5 \text{ mm}$$

The nominal value of the focal length of the lens is $f_L = 30 \text{ cm}$. However, the actual focal length of the single lenses spread considerably. Each lens was measured separately, so the individual result of the student can be compared with the exact value.

b) The refractive index n of the lens material can be evaluated from the equation

$$\frac{1}{f_L} = (n-1) \cdot \frac{2}{r}$$

if the focal length f_L and the curvature radius r of the symmetric biconvex lens are known. f_L was determined in part a) of this problem.

The still unknown curvature radius r of the symmetric biconvex lens is found in the following way: If one pours some water onto the mirror and places the lens in the water,

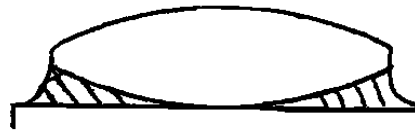

one gets a plane-concave water lens, which has one curvature radius equalling the glass lens' radius and the other radius is ∞ .

Because the refractive index of water is known in this case, one can evaluate the curvature radius through the formula above, where $r_1 = -r$ and $r_2 = \infty$:

$$-\frac{1}{f_w} = (n_w - 1) \cdot \frac{1}{r}.$$

Only the focal length f' of the combination of lenses is directly measured, for which we have

$$\frac{1}{f'} = \frac{1}{f_L} + \frac{1}{f_w}.$$

This focal length is to be determined by a mapping of magnification 1 as above.

Then the focal length of the water lens is $\frac{1}{f_w} = \frac{1}{f'} - \frac{1}{f_L}$

and one has the curvature radius $r = -(n_w - 1) \cdot f_w$.

Now the refractive index of the lens is determined by $n = \frac{r}{2 \cdot f_L} + 1$

with the known values of f_L and r , or, if one wants to express n explicitly through

the measured quantities: $n = \frac{f' \cdot (n_w - 1)}{2 \cdot (f' - f_L)} + 1$.

The nominal values are: $f' = 43.9$ cm, $f_w = -94.5$ cm, $r = 31.2$ cm, $n = 1.52$.

Problem 5: Motion of a rolling cylinder

The rolling motion of a cylinder may be decomposed into rotation about its axis and horizontal translation of the center of gravity. In the present experiment only the translatory acceleration and the forces causing it are determined directly.

Given a cylinder of mass M , radius R , which is placed on a horizontal plane board. At a distance r_i ($i = 1 \dots 6$) from the cylinder axis a force acts on it (see sketch). After letting the cylinder go, it rolls with constant acceleration.

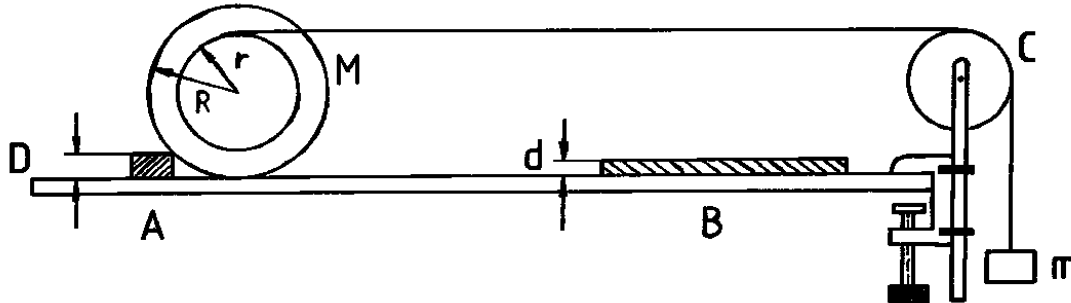

- Determine the linear accelerations a_i ($i = 1 \dots 6$) of the cylinder axis experimentally for several distances r_i ($i = 1 \dots 6$).
- From the accelerations a_i and given quantities, compute the forces F_i which act in horizontal direction between cylinder and plane board.
- Plot the experimental values F_i as functions of r_i . Discuss the results.

Before starting the measurements, adjust the plane board horizontally. For present purposes it suffices to realize the horizontal position with an uncertainty of ± 1 mm of height difference on 1 m of length; this corresponds to the distance between adjacent markings on the level. What would be the result of a not horizontal position of the plane board?

Describe the determination of auxiliary quantities and possible further adjustments; indicate the extent to which misadjustments would influence the results.

The following quantities are given:

R	$=$	5 cm	r_1	$=$	0.75 cm
M	$=$	3.275 kg	r_2	$=$	1.50 cm
m	$=$	2 x 50 g	r_3	$=$	2.25 cm
D	$=$	1.50 cm	r_4	$=$	3.00 cm
d	$=$	0.1 mm	r_5	$=$	3.75 cm
			r_6	$=$	4.50 cm

Mass and friction of the pulleys c may be neglected in the evaluation of the data.

By means of knots, the strings are put into slots at the cylinder. They should be inserted as deeply as possible. You may use the attached paper clip to help in this job.

The stop watch should be connected, as shown in the sketch, with electrical contacts at A and B via an electronic circuit box. The stop watch starts running as soon as the contact at A is opened, and it stops when the contact at B is closed.

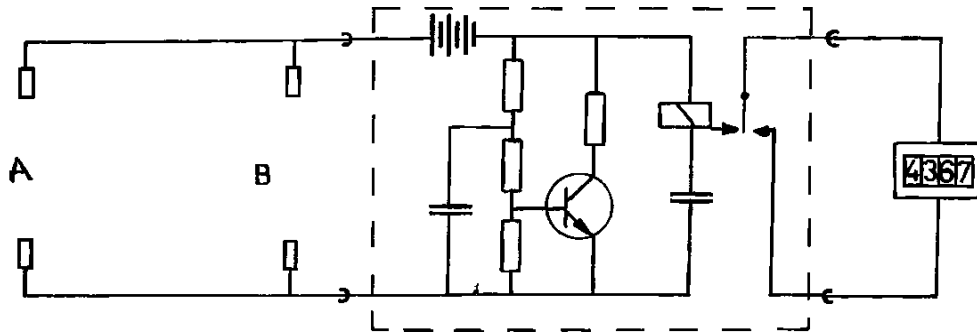

The purpose of the transistor circuit is to keep the relay position after closing of the contact at B, even if this contact is opened afterwards for a few milliseconds by a jump or chatter of the cylinder.

Solution of problem 5:

Theoretical considerations:

a) The acceleration of the center of mass of the cylinder is $a = \frac{2 \cdot s}{t^2}$ (1)

b) Let a_m be the acceleration of the masses m and T the sum of the tensions in the two strings, then

$$T = m \cdot g - m \cdot a_m \quad (2)$$

The acceleration a of the center of mass of the cylinder is determined by the resultant force of the string-tension T and the force of interaction F between cylinder and the horizontal plane.

$$M \cdot a = T - F \quad (3)$$

If the cylinder rotates through an angle θ the mass m moves a distance x_m .

It holds

$$x_m = (R + r) \cdot \theta$$

$$a_m = (R + r) \cdot \frac{a}{R} \quad (4)$$

From (2), (3) and (4) follows $F = mg - \left[M + m \cdot \left(1 + \frac{r}{R} \right) \right] \cdot a$. (5)

- c) From the experimental data we see that for small r_1 the forces $M \cdot a$ and T are in opposite direction and that they are in the same direction for large r_1 .

For small values of r the torque produced by the string-tensions is not large enough to provide the angular acceleration required to prevent slipping. The interaction force between cylinder and plane acts into the direction opposite to the motion of the center of mass and thereby delivers an additional torque.

For large values of r the torque produced by string-tension is too large and the interaction force has such a direction that an opposed torque is produced.

From the rotary-impulse theorem we find

$$T \cdot r + F \cdot R = I \cdot \ddot{\theta} = I \cdot \frac{a}{R},$$

where I is the moment of inertia of the cylinder.

With (3) and (5) you may eliminate T and a from this equation. If the moment of inertia of the cylinder is taken as $I = \frac{1}{2} \cdot M \cdot R^2$ (neglecting the step-up cones) we find after some arithmetical transformations

$$F = mg \cdot \frac{1 - 2 \cdot \frac{r}{R}}{3 + 2 \cdot \frac{m}{M} \cdot \left(1 + \frac{r}{R} \right)^2}.$$

For $r = 0 \rightarrow F = \frac{m \cdot g}{3 + 2 \cdot \frac{m}{M}} > 0$.

For $r = R \Rightarrow F = \frac{-m \cdot g}{3 + 8 \cdot \frac{m}{M}} < 0$.

Because $\frac{m}{M} \ll 1$ it is approximately $F = \frac{1}{3} m \cdot g - \frac{2}{3} \cdot \frac{r}{R}$.

That means: the dependence of F from r is approximately linear. F will be zero if

$$\frac{r}{R} = \frac{m \cdot g}{2}$$

Experimental results:

$$s = L - (2 \cdot R \cdot D + D^2)^{\frac{1}{2}} - (2 \cdot R \cdot d - d^2)^{\frac{1}{2}}$$

$$s = L - 4.5 \text{ cm} = 39.2 \text{ cm} - 4.5 \text{ cm} = 34.7 \text{ cm}$$

r [cm]	t [s]			\bar{t} [s]	a [m/s ²]	F [N]
0.75	1.81	1.82	1.82	1.816	0.211	0.266
1.50	1.71	1.72	1.73	1.720	0.235	0.181
2.25	1.63	1.63	1.64	1.633	0.261	0.090
3.00	1.56	1.56	1.57	1.563	0.284	0.004
3.75	1.51	1.51	1.52	1.513	0.304	-0.066
4.50	1.46	1.46	1.46	1.456	0.328	-0.154

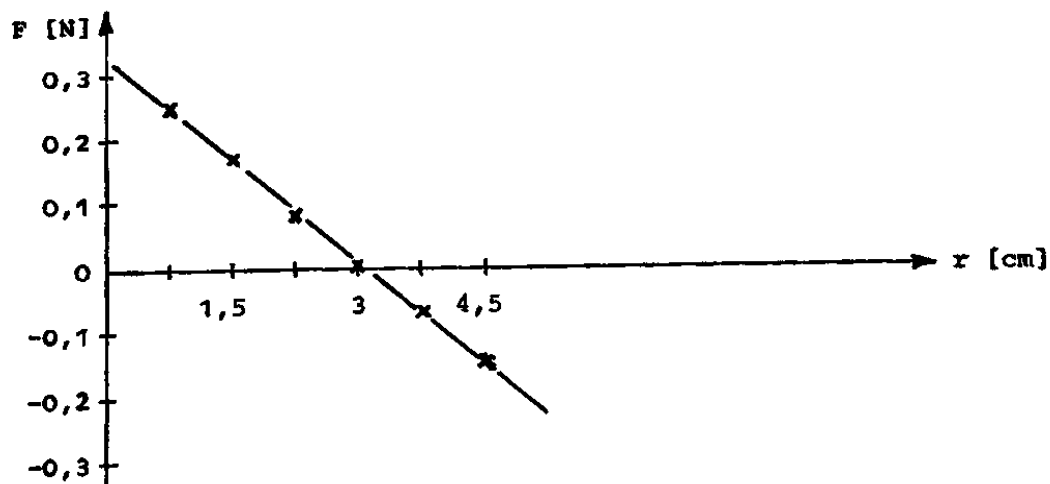

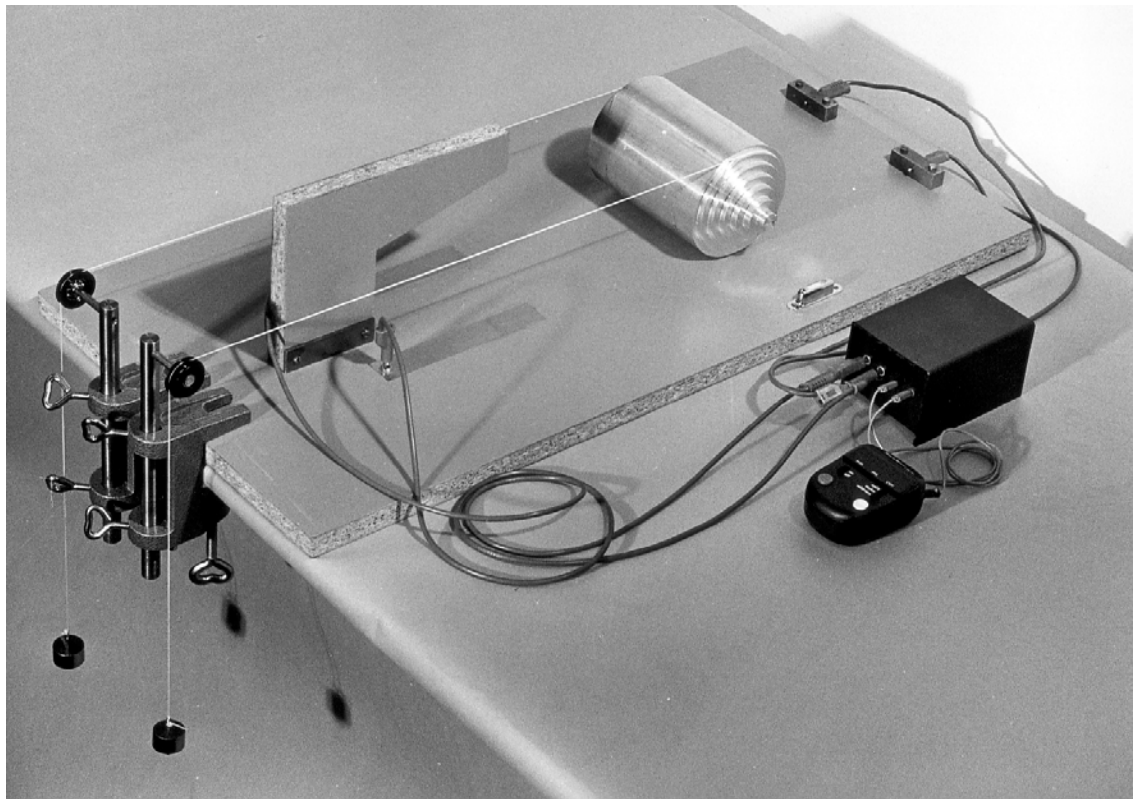

Grading schemes

Theoretical problems

Problem 1: Fluorescent lamp	pts.
Part a	2
Part b	1
Part c	1
Part d	1
Part e	1
Part f	1
Part g	2
Part h	1
	10

Problem 2: Oscillating coat hanger	pts.
equation (1)	1,5
equation (2)	1,5
equation (4)	3
equation (5)	2
numerical value for T	1
	10

Problem 3: Hot-air-balloon	pts.
Part a	3
Part b	2
Part c	3
Part d	2
	10

Experimental problems

Problem 4: Lens experiment	pts.
correct description of experimental procedure	1
selection of magnification one	0.5
parallaxe for verifying his magnification	1
$f_L = g = b$ with derivation	1
several measurements with suitable averaging or other determination of error interval	1
taking into account the lens thickness and computing f_L , including the error	0.5
idea of water lens	0.5
theory of lens combination	1
measurements of f'	0.5
calculation of n and correct result	1
	8

Problem 5: Motion of a rolling cylinder	pts.
Adjustment mentioned of strings a) horizontally and b) in direction of motion	0.5
Indication that angle offset of strings enters the formula for the acting force only quadratically, i.e. by its cosine	0.5
Explanation that with non-horizontal position, the force $m \cdot g$ is to be replaced by $m \cdot g \pm M \cdot g \cdot \sin \alpha$	1.0
Determination of the running length according for formula $s = L - (2 \cdot R \cdot D + D^2)^{1/2} - (2 \cdot R \cdot d + d^2)^{1/2}$ including correct numerical result	1.0
Reliable data for rolling time	1.0
accompanied by reasonable error estimate	0.5
Numerical evaluation of the F_i	0.5
Correct plot of F_i (v_i)	0.5
Qualitative interpretation of the result by intuitive consideration of the limiting cases $r = 0$ and $r = R$	1.0
Indication of a quantitative, theoretical interpretation using the concept of moment of inertia	1.0
Knowledge and application of the formula $a = 2 s / t^2$	0.5
Force equation for small mass and tension of the string $m \cdot (g - a_m) = T$	1.0
Connection of tension, acceleration of cylinder and reaction force $T - F = M \cdot a$	1.0
Connection between rotary and translatory motion $x_m = (R + r) \cdot \theta$	0.5
$a_m = (1 + r/R) \cdot a$	0.5
Final formula for the reaction force $F = m \cdot g - (M + m \cdot (1 + r/R)) \cdot a$	1.0
If final formulae are given correctly, the knowledge for preceding equations must be assumed and is graded accordingly.	
	12

Mechanics – Problem I (8 points)

Jumping particle

A particle moves along the positive axis Ox (one-dimensional situation) under a force that's projection on Ox is $F_x = F_0$ as represented in the figure below (as function of x). At the origin of Ox axis is placed a perfectly reflecting wall.

A friction force of constant modulus $F_f = 1,00\text{ N}$ acts anywhere the particle is situated.

The particle starts from the point $x = x_0 = 1,00\text{ m}$ having the kinetic energy $E_c = 10,0\text{ J}$.

- Find the length of the path of the particle before it comes to a final stop
- Sketch the potential energy $U(x)$ of the particle in the force field F_x .
- Draw qualitatively the dependence of the particle speed as function of his coordinate x .

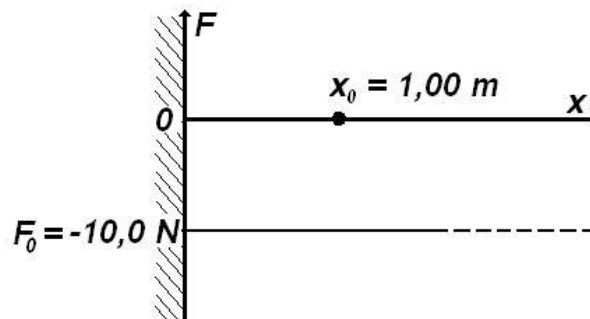

Electricity – Problem II (8 points)

Different kind of oscillation

Let's consider the electric circuit in the figure, for which $L_1 = 10\text{ mH}$, $L_2 = 20\text{ mH}$, $C_1 = 10\text{ nF}$, $C_2 = 5\text{ nF}$ and $R = 100\text{ k}\Omega$. The switch K being closed the circuit is coupled with a source of alternating current. The current furnished by the source has constant intensity while the frequency of the current may be varied.

- Find the ratio of frequency f_m for which the active power in circuit has the maximum value P_m and the frequency difference $\Delta f = f_+ - f_-$ of the frequencies f_+ and f_- for which the active power in the circuit is half of the maximum power P_m .

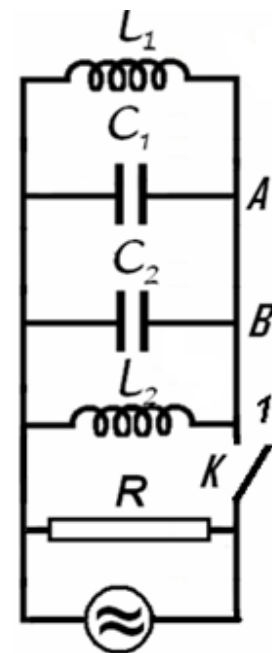

The switch K is now open. In the moment t_0 immediately after the switch is open the intensities of the currents in the coils L_1 and $i_{01} = 0,1\text{ A}$ and



$i_{02} = 0,2 \text{ A}$ L_1 (the currents flow as in the figure); at the same moment, the potential difference on the capacitor with capacity C_1 is $u_0 = 40 \text{ V}$:

- Calculate the frequency of electromagnetic oscillation in $L_1 C_1 C_2 L_2$ circuit;
- Determine the intensity of the electric current in the AB conductor;
- Calculate the amplitude of the oscillation of the intensity of electric current in the coil L_1 .

Neglect the mutual induction of the coils, and the electric resistance of the conductors. Neglect the fast transition phenomena occurring when the switch is closed or opened.

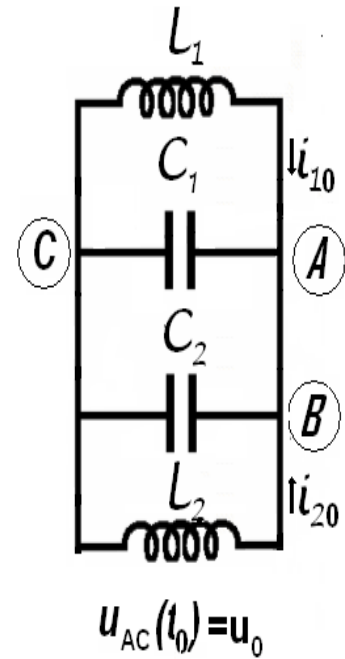

Optics – Problem III (7points)

Prisms

Two dispersive prisms having apex angles $\hat{A}_1 = 60^\circ$ and $\hat{A}_2 = 30^\circ$ are glued as in the figure below ($\hat{C} = 90^\circ$). The dependences of refraction indexes of the prisms on the wavelength are given by the relations

$$n_1(\lambda) = a_1 + \frac{b_1}{\lambda^2};$$

$$n_2(\lambda) = a_2 + \frac{b_2}{\lambda^2}$$

were

$$a_1 = 1,1, \quad b_1 = 1 \cdot 10^5 \text{ nm}^2, \quad a_2 = 1,3, \quad b_2 = 5 \cdot 10^4 \text{ nm}^2.$$

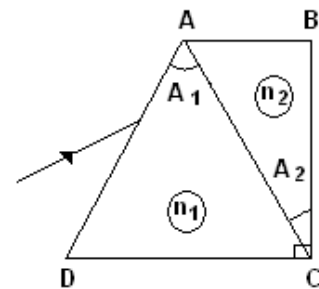

- Determine the wavelength λ_0 of the incident radiation that pass through the prisms without refraction on AC face at any incident angle; determine the corresponding refraction indexes of the prisms.
- Draw the ray path in the system of prisms for three different radiations λ_{red} , λ_0 , λ_{violet} incident on the system at the same angle.
- Determine the minimum deviation angle in the system for a ray having the wavelength λ_0 .
- Calculate the wavelength of the ray that penetrates and exits the system along directions parallel to DC .



Atoms - Problem IV (7 points)

Compton scattering

A photon of wavelength λ_i is scattered by a moving, free electron. As a result the electron stops and the resulting photon of wavelength λ_0 scattered at an angle $\theta = 60^\circ$ with respect to the direction of the incident photon, is again scattered by a second free electron at rest. In this second scattering process a photon with wavelength of $\lambda_f = 1,25 \times 10^{-10} \text{ m}$ emerges at an angle $\theta = 60^\circ$ with respect to the direction of the photon of wavelength λ_0 . Find the de Broglie wavelength for the first electron before the interaction. The following constants are known:

$h = 6,6 \times 10^{-34} \text{ J} \cdot \text{s}$ - Planck's constant

$m = 9,1 \times 10^{-31} \text{ kg}$ - mass of the electron

$c = 3,0 \times 10^8 \text{ m/s}$ - speed of light in vacuum

The purpose of the problem is to calculate the values of the speed, momentum and wavelength of the first electron.

To characterize the photons the following notation are used:

Table 4.1

	initial photon	photon – after the first scattering	final photon
momentum	\vec{p}_i	\vec{p}_0	\vec{p}_f
energy	E_i	E_0	E_f
wavelength	λ_i	λ_0	λ_f

To characterize the electrons one uses

Table 4.2

	first electron before collision	first electron after collision	second electron before collision	Second electron after collision
momentum	\vec{p}_{1e}	0	0	\vec{p}_{2e}
energy	E_{1e}	E_{0e}	E_{0e}	E_{2e}
speed	\vec{v}_{1e}	0	0	\vec{v}_{2e}



IPhO's LOGO – Problem V

The Logo of the International Physics Olympiad is represented in the figure below.

The figure presents the phenomenon of the curving of the trajectory of a jet of fluid around the shape of a cylindrical surface. The trajectory of fluid is not like the expected dashed line but as the circular solid line.

Qualitatively explain this phenomenon (first observed by Romanian engineer Henry Coanda in 1936).

This problem will be not considered in the general score of the Olympiad. The best solution will be awarded a special prize.



Mechanics – Problem I (8 points)

A particle moves along the positive axis Ox (one-dimensional situation) under a force having a projection $F_x = F_0$ on Ox , as represented, as function of x , in the figure 1.1. In the origin of the Ox axis is placed a perfectly reflecting wall.

A friction force, with a constant modulus $F_f = 1,00\text{ N}$, acts everywhere on the particle.

The particle starts from the point $x = x_0 = 1,00\text{ m}$ having the kinetic energy $E_c = 10,0\text{ J}$.

- Find the length of the path of the particle until its' final stop
- Plot the potential energy $U(x)$ of the particle in the force field F_x .
- Qualitatively plot the dependence of the particle's speed as function of its' x coordinate.

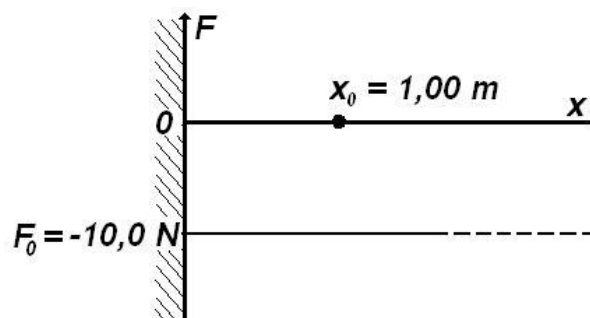

Figure 1.1

Problem I – Solution

a. It is possible to make a model of the situation in the problem, considering the Ox axis vertically oriented having the wall in its' lower part. The conservative force F_x could be the weight of the particle. One may present the motion of the particle as the vertical motion of a small elastic ball elastically colliding with the ground and moving with constant friction through the medium. The friction force is smaller than the weight.

The potential energy of the particle can be represented in analogy to the gravitational potential energy of the ball, $m \cdot g \cdot h$, considering $m \cdot g = |F_x|$; $h = x$. As is very well known, in the field of a conservative force, the variation of the potential energy depends only on the initial and final positions of the particle, being independent of the path between those positions.

For the situation in the problem, when the particle moves towards the wall, the force acting on it is directed towards the wall and has the modulus l

$$F_{\leftarrow} = |F_x| - F_f \quad (1.1)$$

$$F_{\leftarrow} = 9\text{ N} \quad (1.2)$$

As a consequence, the motion of the particle towards the wall is a motion with a constant acceleration having the modulus

$$a_{\leftarrow} = \frac{F_{\leftarrow}}{m} = \frac{|F_x| - F_f}{m} \quad (1.3)$$

During the motion, the speed of the particle increases.



Hitting the wall, the particle starts moving in opposite direction with a speed equal in modulus with the one it had before the collision.

When the particle moves away from the wall, in the positive direction of the Ox axis, the acting force is again directed towards to the wall and has the magnitude

$$F_{\rightarrow} = |F_x| + F_f \quad (1.4)$$

$$F_{\rightarrow} = 11N \quad (1.5)$$

Correspondingly, the motion of the particle from the wall is slowed down and the magnitude of the acceleration is

$$a_{\rightarrow} = \frac{F_{\rightarrow}}{m} = \frac{|F_x| + F_f}{m} \quad (1.6)$$

During this motion, the speed of the particle diminishes to zero.

Because during the motion a force acts on the particle, the body cannot have an equilibrium position in any point on axis – the origin making an exception as the potential energy vanishes there. The particle can definitively stop only in this point.

The work of a conservative force from the point having the coordinate $x_0 = 0$ to the point x , $L_{0 \rightarrow x}$ is correlated with the variation of the potential energy of the particle $U(x) - U(0)$ as follows

$$\begin{cases} U(x) - U(0) = -L_{0 \rightarrow x} \\ U(x) - U(0) = -\int_0^x \vec{F}_x \cdot d\vec{x} = \int_0^x |F_x| \cdot dx = |F_x| \cdot x \end{cases} \quad (1.7)$$

Admitting that the potential energy of the particle vanishes for $x = 0$, the initial potential energy of the particle $U(x_0)$ in the field of conservative force

$$F_x(x) = F_0 \quad (1.8)$$

can be written

$$U(x_0) = |F_0| \cdot x_0 \quad (1.9)$$

The initial kinetic energy $E(x_0)$ of the particle is – as given

$$E(x_0) = E_c \quad (1.10)$$

and, consequently the total energy of the particle $W(x_0)$ is

$$W(x_0) = U(x_0) + E_c \quad (1.11)$$

The draw up of the particle occurs when the total energy of the particle is entirely exhausted by the work of the friction force. The distance covered by the particle before it stops, D , obeys

$$\begin{cases} W(x_0) = D \cdot F_f \\ U(x_0) + E_c = D \cdot F_f \\ |F_x| \cdot x_0 + E_c = D \cdot F_f \end{cases} \quad (1.12)$$

so that ,



$$D = \frac{|F_x| \cdot x_0 + E_c}{F_f} \tag{1.13}^*$$

and

$$D = 20m \tag{1.14}^*$$

The relations (1.13) and (1.14) represent the answer to the question I.a.

b. The relation (1.7) written as

$$U(x) = |F_x| \cdot x \tag{1.15}$$

gives the linear dependence of the potential energy to the position .

If the motion occurs without friction, the particle can reach a point A situated at the distance δ apart from the origin in which the kinetic energy vanishes. In the point A the energy of the particles is entirely potential.

The energy conservation law for the starting point and point A gives

$$\begin{cases} E_c + |F_x| \cdot x_0 = |F_x| \cdot \delta \\ \delta = x_0 + \frac{E_c}{|F_x|} \end{cases} \tag{1.16}$$

The numerical value of the position of point A , furthest away from the origin, is

$$\delta = 2m$$

if the motion occurs without friction.

The representation of the dependence of the potential energy on the position in the domain $(0, \delta)$ is represented in the figure 1.2.

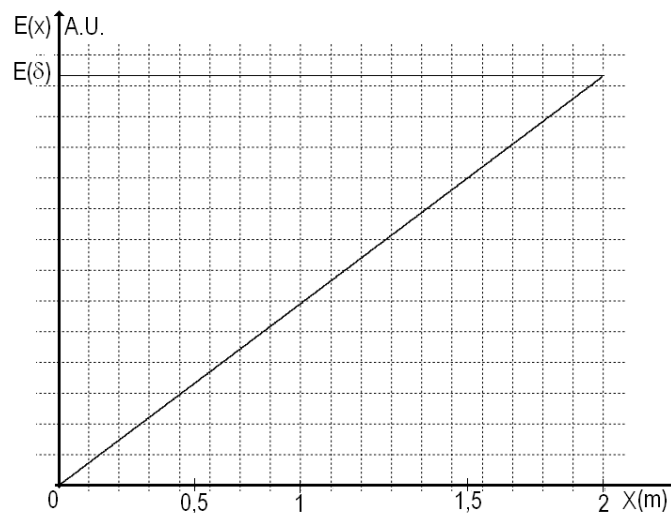

Figure 1.2

During the real motion of the particle (with friction) the extreme positions reached by the particle are smaller than δ (because of the leak of energy due to friction).

The graph in the figure 1.2 is the answer to the question I.b.



c. During the motion of the particle its energy decrease because of the dissipation work of the friction force. The speed of the particle has a local maximum near the wall. Denoting v_k the speed of the particle just before its' k^{th} collision with the wall and v_{k+1} the speed just before its' next collision,

$$v_k > v_{k+1}$$

Among two successive collisions, the particle reaches its' x_k positions in which its' speed vanishes and the energy of the particle is purely potential. These positions are closer and closer to the wall because a part of the energy of the particle is dissipated through friction.

$$x_{k+1} < x_k \quad (1.17)$$

Case 1

When the particle moves towards the wall, both its' speed and its' kinetic energy increases. The potential energy of the particle decreases. During the motion – independent of its' direction- energy is dissipated through the friction force.

The potential energy of the particle, $U(x)$, the kinetic energy $E(x)$ and the total energy of the particle during this part of the motion $W(x)$ obey the relation

$$W(x_0) - W(x) = F_f \cdot (x_0 - x) \quad (1.18)$$

the position x lying in the domain

$$x \in (0, x_0) \quad (1.19)$$

covered from x_0 towards origin. The relation (1.18) can be written as

$$[E_c + |F_x| \cdot x_0] - \left[\frac{m \cdot v^2}{2} + |F_x| \cdot x \right] = F_f \cdot (x_0 - x) \quad (1.20)$$

so that

$$\begin{cases} v^2 = \frac{2}{m} [E_c + |F_x| \cdot x_0 - |F_x| \cdot x - F_f \cdot (x_0 - x)] \\ v^2 = \frac{2}{m} [E_c + x_0(|F_x| - F_f) - x(|F_x| - F_f)] \end{cases} \quad (1.21)$$

and by consequence

$$v = -\sqrt{\frac{2}{m} [E_c + x_0(|F_x| - F_f) - x(|F_x| - F_f)]} \quad (1.22)$$

The minus sign in front of the magnitude of the speed indicates that the motion of the particle occurs into the negative direction of the coordinate axis.

Using the problem data

$$\begin{cases} v^2 = \frac{2}{m} (19 - 9 \cdot x) \\ v = -\sqrt{\frac{2}{m} (19 - 9 \cdot x)} \end{cases} \quad (1.23)$$

The speed of the particle at the first collision with the wall $v_{1\leftarrow}$ can be written as



$$v_{1\leftarrow} = -\sqrt{\frac{2}{m} [E_c + x_0 (|F_x| - F_f)]} \tag{1.24}$$

and has the value

$$v_{1\leftarrow} = -\sqrt{\frac{2}{m} 19} \tag{1.25}$$

The total energy near the wall, purely kinetic $E_{1\leftarrow}$, has the expression

$$E_{1\leftarrow} = E_c + x_0 (|F_x| - F_f) \tag{1.26}$$

The numerical value of this energy is

$$E_{1\leftarrow} = 19 J \tag{1.27}$$

The graph in the figure (1.3) gives the dependence on position of the square of the speed for the first part of the particle's motion.

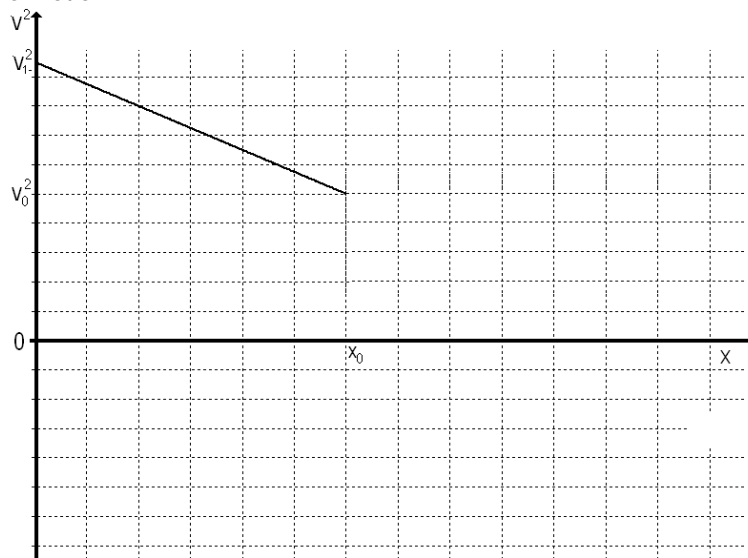

Figure 1.3

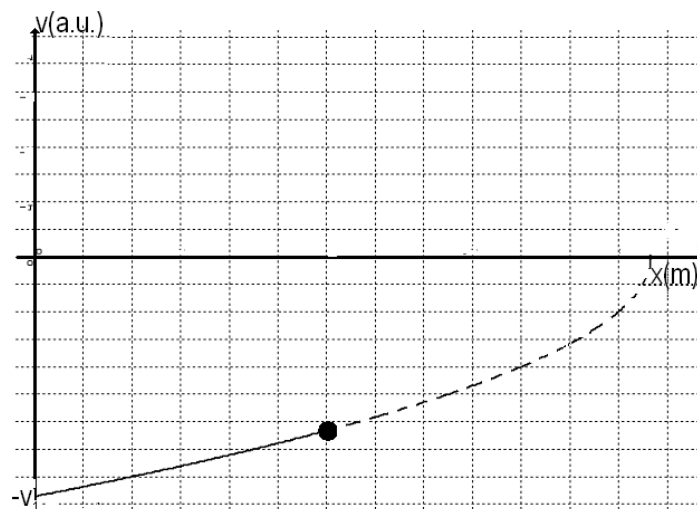

Figure 1.4



The graph in the figure (1.4) presents the speed's dependence on the position in this first part of the particle's motion (towards the wall).

After the collision with the wall, the speed of the particle, $v_{1\rightarrow}$, has the same magnitude as the speed just before the collision but it is directed in the opposite way. In the graphical representation of the speed as a function of position, the collision with the wall is represented as a jump of the speed from a point lying on negative side of the speed axis to a point lying on positive side of the speed axis. The absolute value of the speed just before and immediately after the collision is the same as represented in the figure 1.5.

$$v_{1\rightarrow} = \sqrt{\frac{2}{m} [E_c + x_0 (|F_x| - F_f)]} \quad (1.28)$$

After the first collision, the motion of the particle is slowed down with a constant deceleration a_{\rightarrow} and an initial speed $v_{1\rightarrow}$.

This motion continues to the position x_1 where the speed vanishes.

From Galileo law it can be inferred that

$$\begin{cases} 0 = v_{1\rightarrow}^2 - 2 \cdot a_{\rightarrow} \cdot x_1 \\ x_1 = \frac{v_{1\rightarrow}^2}{2 \cdot a_{\rightarrow}} = \frac{\frac{2}{m} [E_c + x_0 (|F_x| - F_f)]}{2 \cdot \frac{|F_x| + F_f}{m}} = \frac{[E_c + x_0 (|F_x| - F_f)]}{|F_x| + F_f} \end{cases} \quad (1.29)$$

The numerical value of the position x_1 is

$$x_1 = \frac{19}{11} m \quad (1.30)$$

For the positions

$$x \in (0, x_1) \quad (1.31)$$

covered from the origin towards x_1 the total energy $W(x)$ has the expression

$$W(x) = \frac{m \cdot v^2}{2} + |F_x| \cdot x \quad (1.32)$$

From the wall, the energy of the particle diminishes because of the friction – that is

$$\begin{cases} E_{1\leftarrow} - W(x) = F_f \cdot x \\ E_c + x_0 (|F_x| - F_f) - \frac{m \cdot v^2}{2} - |F_x| \cdot x = F_f \cdot x \end{cases} \quad (1.33)$$

The square of the magnitude of the speed is

$$\begin{cases} v^2 = \frac{2}{m} [E_c + x_0 (|F_x| - F_f) - (|F_x| + F_f) \cdot x] \\ v^2 = \frac{2}{m} (|F_x| + F_f) \cdot (x_1 - x) \end{cases} \quad (1.34)$$

and the speed is

$$v = \sqrt{\frac{2}{m} [E_c + x_0 (|F_x| - F_f) - (|F_x| + F_f) \cdot x]} \quad (1.35)$$

Using the furnished data results

$$v^2 = \frac{2}{m} [19 - 11 \cdot x] \tag{1.36}$$

and respectively

$$v = \sqrt{\frac{2}{m} [19 - 11 \cdot x]} \tag{1.37}$$

For the positions lying in the domain $x \in (0, x_1)$ - (which correspond to a second part of the motion of particle) the figure 1.5 gives the dependence of the speed on the position.

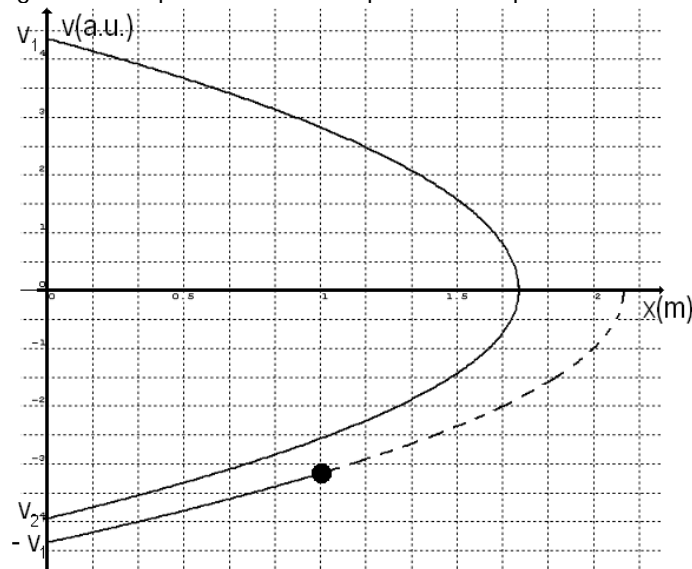

Figure 1.5

As can be observed in the figure, after reaching the furthest away position, x_1 , the particle moves towards the origin, without an initial speed, in an accelerated motion having an acceleration with the magnitude of $a_{\leftarrow} = (|F_x| - F_f)/m$. After the collision with the wall, the particle has a velocity equal in magnitude but opposite in direction with the one it had just before the collision.

When the particle reaches a point in the domain $(0, x_1)$ moving from x_1 towards the origin its' total energy $W(x)$ has the expression (1.32).

Starting from x_1 , because of the dissipation determined by the friction force, the energy changes to the value corresponding to the position with coordinate x .

$$\begin{cases} |F_x| \cdot x_1 - W(x) = F_f \cdot (x_1 - x) \\ |F_x| \cdot x_1 - \frac{m \cdot v^2}{2} - |F_x| \cdot x = F_f \cdot (x_1 - x) \end{cases} \tag{1.38}$$

The square of the speed has the expression

$$\begin{cases} v^2 = \frac{2}{m} [(|F_x| - F_f) \cdot (x_1 - x)] \\ v^2 = \frac{2}{m} \left[\frac{[E_c + x_0 (|F_x| - F_f)]}{|F_x| + F_f} - x \right] \cdot (|F_x| - F_f) \end{cases} \tag{1.39}$$



and the speed is

$$v = \sqrt{\frac{2}{m} \left[\frac{[E_c + x_0(|F_x| - F_f)]}{|F_x| + F_f} - x \right] \cdot (|F_x| - F_f)} \quad (1.40)$$

Using the given data, for a position in the domain $(0, x_1)$

$$v^2 = \frac{2}{m} \left[\frac{19}{11} - x \right] \cdot 9 \quad (1.41)$$

respectively

$$v = -\sqrt{\frac{2}{m} \left[\frac{19}{11} - x \right] \cdot 9} \quad (1.42)$$

The speed of the particle when it reaches for the second time the wall has - using (1.39) - the expression

$$v_{2\leftarrow} = -\sqrt{\frac{2}{m} \left\{ \frac{[E_c + x_0(|F_x| - F_f)]}{|F_x| + F_f} \cdot (|F_x| - F_f) \right\}} \quad (1.43)$$

The resulting numerical value is

$$v_{2\leftarrow} = -\sqrt{\frac{2 \cdot 171}{m \cdot 11}} \quad (1.44)$$

Concluding, after the first collision and first recoil, the particle moves away from the wall, reaches again a position where the speed vanishes and then comes back to the wall. The speed of the particle hitting again the wall is smaller than before – as in the figure 1.5.

As it was denoted before v_k is the speed of the particle just before its' k^{th} run and x_k is the coordinate of the furthest away point reached during the k^{th} run.

The energy of the particle starting from the wall is

$$E_k = \frac{v_k^2 \cdot m}{2} = W_k(0) \quad (1.45)$$

In the point x_k , the furthest away from the origin after k^{th} collision, the energy verifies the relation

$$U_k = x_k \cdot |F_x| = W_k(x_k) \quad (1.46)$$

The variation of the energy between starting point and point x_k is

$$\frac{v_k^2 \cdot m}{2} - x_k \cdot |F_x| = F_f \cdot x_k \quad (1.47)$$

so that

$$x_k = \frac{v_k^2 \cdot m}{2 \cdot (|F_x| + F_f)} \quad (1.48)$$

After the particle reaches point x_k the direction of the speed changes and, when the particle reaches again the wall



$$\frac{v_{k+1}^2 \cdot m}{2} = E_{k+1} = W_{k+1}(0) \quad (1.49)$$

The energy conservation law for the x_k point and the state when the particle reaches again the wall gives

$$x_k \cdot |F_x| - \frac{v_{k+1}^2 \cdot m}{2} = F_f \cdot x_k \quad (1.50)$$

so that

$$v_{k+1}^2 = \frac{2}{m} x_k (|F_x| - F_f) \quad (1.51)$$

Considering (1.48), the relation (1.51) becomes

$$v_{k+1}^2 = v_k^2 \cdot \frac{|F_x| - F_f}{|F_x| + F_f} \quad (1.52)$$

Between two consequent collisions the speed diminishes in a geometrical progression having the ratio q . This ratio has the expression

$$q = \sqrt{\frac{|F_x| - F_f}{|F_x| + F_f}} \quad (1.53)$$

and the value

$$q = \sqrt{\frac{9}{11}} \quad (1.54)$$

For the $k+1$ collision the relation (1.48) becomes

$$x_{k+1} = \frac{v_{k+1}^2 \cdot m}{2 \cdot (|F_x| + F_f)} \quad (1.55)$$

Taking into account (1.52), the ratio of the successive extreme positions can be written as

$$\begin{cases} \frac{x_{k+1}}{x_k} = \frac{|F_x| - F_f}{|F_x| + F_f} = q^2 \\ x_{k+1} = q^2 \cdot x_k \end{cases} \quad (1.56)$$

From the k run towards origin, (analogous to (1.39)), the dependence of the square of the speed on position can be written as $v_{(k,\leftarrow)}^2$

$$\begin{cases} v_{(k,\leftarrow)}^2 = \frac{2}{m} [(|F_x| - F_f) \cdot (x_k - x)] \\ v_{(k,\leftarrow)}^2 = \frac{2}{m} [(|F_x| - F_f) \cdot (x_1 \cdot q^{2k} - x)] \end{cases} \quad (1.57)$$

or, using the data



$$v_{(k,\leftarrow)}^2 = \frac{2}{m} \left[9 \cdot \left(\frac{19}{11} \cdot \left(\frac{9}{11} \right)^k - x \right) \right] \tag{1.58}$$

For the k^{th} run from the origin (analogous with (1.34)), the dependence on the position of the square of the magnitude of the speed $v_{(k,\rightarrow)}^2$ can be written as

$$\begin{cases} v_{(k,\rightarrow)}^2 = \frac{2}{m} [(|F_x| + F_f) \cdot (x_k - x)] \\ v_{(k,\rightarrow)}^2 = \frac{2}{m} [(|F_x| + F_f) \cdot (x_1 \cdot q^{2k} - x)] \end{cases} \tag{1.59}$$

Using given data

$$v_{(k,\rightarrow)}^2 = \frac{2}{m} \left[11 \cdot \left(\frac{19}{11} \cdot \left(\frac{9}{11} \right)^k - x \right) \right] \tag{1.60}$$

The evolution of the square of the speed as function of position is represented in the figure 1.6.

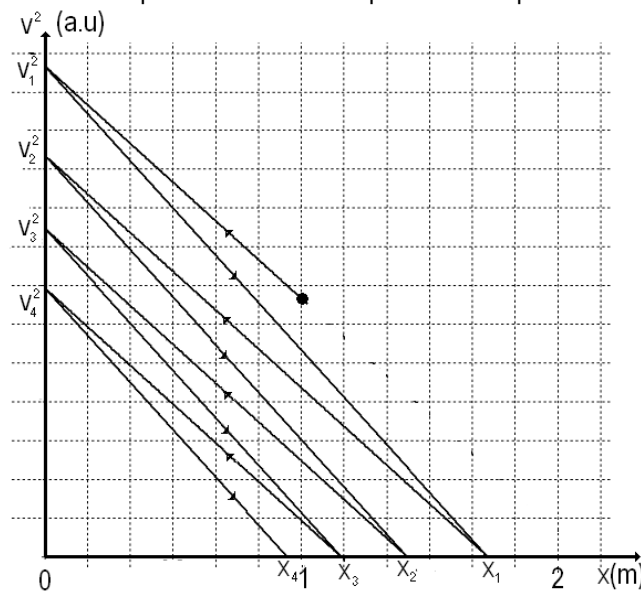

Figure 1.6

And the evolution of the speed as function of position is represented in the figure 1.7.

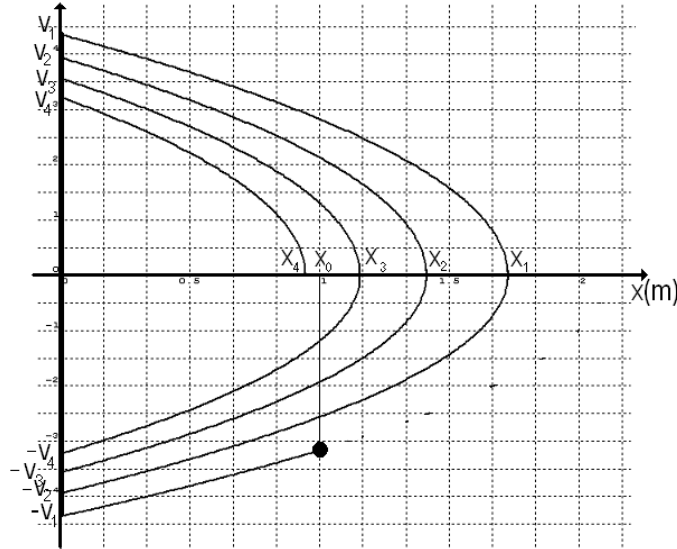

Figure 1.7

The sum of the progression given in (1.56) gives half of the distance covered by the particle after the first collision.

$$\sum_{k=1}^{\infty} x_k = x_1 \frac{1}{1-q^2} \tag{1.61}$$

Considering (1.53) and (1.29)

$$\sum_{k=1}^{\infty} x_k = \frac{E_c + x_0 \cdot (|F_x| - F_f)}{2 \cdot F_f} \tag{1.62}$$

Numerically,

$$\sum_{k=1}^{\infty} x_k = \frac{19}{2} m \tag{1.63}$$

The total covered distance is

$$\begin{cases} D = 2 \cdot \sum_{k=1}^{\infty} x_k + x_0 \\ D = 20 m \end{cases} \tag{1.64}$$

which is the same with (1.14).

Case 2

If the particle starts from the x_0 position moving in the positive direction of the coordinate axis Ox its' speed diminishes and its' kinetic energy also diminishes while its' potential energy increases to a maximum in the x_1 ' position where the speed vanishes. During this motion the energy is dissipated due to the friction.

The total energy $W(x)$, for the positions x between x_0 and x_1 ' verify the relation

$$W(x_0) - W(x) = F_f \cdot (x - x_0) \tag{1.65}$$

the position x lying in the domain



$$x \in (x_0, x_1) \tag{1.66}$$

when the particle moves from x_0 in the positive direction of the axis. The relation (1.65) becomes

$$[E_c + |F_x| \cdot x_0] - \left[\frac{m \cdot v^2}{2} + |F_x| \cdot x \right] = F_f \cdot (x - x_0) \tag{1.67}$$

so that

$$\begin{cases} v^2 = \frac{2}{m} [E_c + |F_x| \cdot x_0 - |F_x| \cdot x - F_f \cdot (x - x_0)] \\ v^2 = \frac{2}{m} [E_c + x_0(|F_x| + F_f) - x(|F_x| + F_f)] \end{cases} \tag{1.68}$$

and

$$v = \sqrt{\frac{2}{m} [E_c + x_0(|F_x| + F_f) - x(|F_x| + F_f)]} \tag{1.69}$$

Using provided data

$$\begin{cases} v^2 = \frac{2}{m} (21 - 11 \cdot x) \\ v = \sqrt{\frac{2}{m} (21 - 11 \cdot x)} \end{cases} \tag{1.70}$$

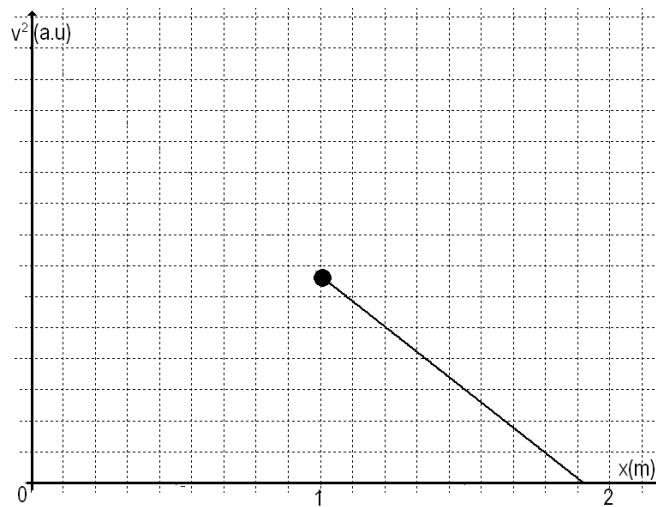

Figure 1.8

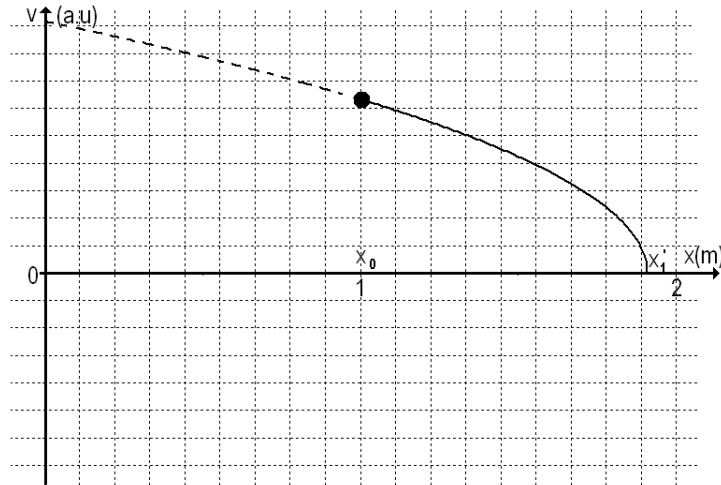

Figure 1.9

The graph in the figure (1.8) presents the dependence of the square speed on the position for the motion in the domain $x \in (x_0, x_1')$. The particle moves in the positive direction of the coordinate axis Ox . This motion occurs until the position x_1' - when the speed vanishes - is reached. From the relation (1.68), in which we take the modulus of the speed zero, results

$$x_1' = x_0 + \frac{E_c}{|F_x| + F_f} \tag{1.71}$$

the numerical value for x_1' is

$$x_1' = \frac{21}{11} m \tag{1.72}$$

After furthest away position x_1' is reached, the particle moves again towards the origin, without initial speed, in a speeded up motion having an acceleration of magnitude $a_{\leftarrow} = (|F_x| - F_f)/m$. After the collision with the wall, the particle has a velocity $v_{1\rightarrow}'$ equal in magnitude but opposite direction with the one it had before the collision $v_{1\leftarrow}'$.

When the particle is at a point lying in the domain $(0, x_1')$ running from x_1' to the origin, its' total energy $W(x)$ has the expression

$$W(x) = \frac{m \cdot v^2}{2} + |F_x| \cdot x \tag{1.73}$$

Because of friction, the value of the energy decreases from the one it had at x_1' to the corresponding to the x position

$$\begin{cases} |F_x| \cdot x_1' - W(x) = F_f \cdot (x_1' - x) \\ |F_x| \cdot x_1' - \frac{m \cdot v^2}{2} - |F_x| \cdot x = F_f \cdot (x_1' - x) \end{cases} \tag{1.74}$$

The square of the speed has the expression

$$v^2 = \frac{2}{m} [(|F_x| - F_f) \cdot (x_1' - x)] \tag{1.75}$$

and the speed is



$$v = -\sqrt{\frac{2}{m} [(|F_x| - F_f) \cdot (x_1' - x)]} \quad (1.76)$$

For the given data, in the domain, $(0, x_1')$

$$v^2 = \frac{2}{m} \left[\frac{21}{11} - x \right] \cdot 9 \quad (1.77)$$

respectively

$$v = -\sqrt{\frac{2}{m} \left[\frac{21}{11} - x \right] \cdot 9} \quad (1.78)$$

The speed of the particle hitting a second time the wall is – according to (1.78)-

$$v_{1\leftarrow}' = -\sqrt{\frac{2}{m} [(|F_x| - F_f) \cdot x_1']} \quad (1.79)$$

and has the value

$$v_{1\leftarrow}' = -\sqrt{\frac{2 \cdot 189}{m \cdot 11}} \quad (1.80)$$

Concluding, after the first collision and first recoil, the particle moves away from the wall, reaches again a position where the speed vanishes and then comes back to the wall. The speed of the particle hitting again the wall is smaller than before – as in the figure 1.11.

Denoting v_k' the speed at the beginning of the k^{th} run and x_k' the coordinate of the furthest away point during the k^{th} run, the energy of the particle leaving the wall is

$$E_k' = \frac{v_k'^2 \cdot m}{2} = W_k'(0) \quad (1.81)$$

In the position x_k' after the k departure from the wall, the energy is

$$U_k' = x_k' \cdot |F_x| = W_k'(x_k') \quad (1.82)$$

The variation of the total energy has the expression

$$\frac{v_k'^2 \cdot m}{2} - x_k' \cdot |F_x| = F_f \cdot x_k' \quad (1.83)$$

so that

$$x_k' = \frac{v_k'^2 \cdot m}{2 \cdot (|F_x| + F_f)} \quad (1.84)$$

After the particle reaches the position x_k' the direction of the speed changes and, when the particle hits the wall,

$$\frac{v_{k+1}'^2 \cdot m}{2} = E_{k+1}' = W_{k+1}'(0) \quad (1.85)$$

The energy conservation law for the x_k' position and the point in which the particle hits the wall gives



$$x_k' \cdot |F_x| - \frac{v_{k+1}^2 \cdot m}{2} = F_f \cdot x_k' \quad (1.86)$$

so that

$$v_{k+1}^2 = \frac{2}{m} x_k' (|F_x| - F_f) \quad (1.87)$$

Considering (1.84), the relation (1.87) becomes

$$v_{k+1}^2 = v_k^2 \cdot \frac{|F_x| - F}{|F_x| + F} \quad (1.88)$$

Between two successive collisions the speed diminishes in a geometrical progression with the ratio q

$$q = \sqrt{\frac{|F_x| - F}{|F_x| + F}} \quad (1.89)$$

Using the data provided

$$q = \sqrt{\frac{9}{11}} \quad (1.90)$$

From $(k+1)^{\text{th}}$, collision the relation (1.84) is written as

$$x_{k+1}' = \frac{v_{k+1}^2 \cdot m}{2 \cdot (|F_x| + F_f)} \quad (1.91)$$

Considering (1.84) and (1.91), the ratio of the extreme positions in two successive runs is

$$\begin{cases} \frac{x_{k+1}'}{x_k'} = \frac{|F_x| - F_f}{|F_x| + F_f} = q^2 \\ x_{k+1}' = q^2 \cdot x_k' \end{cases} \quad (1.92)$$

For the k^{th} run towards the origin, analogous to (1.57), one may write the dependence of the square speed $v_{(k,\leftarrow)}^2$ as function of the position as

$$\begin{cases} v_{(k,\leftarrow)}^2 = \frac{2}{m} [(|F_x| - F_f) \cdot (x_k' - x)] \\ v_{(k,\leftarrow)}^2 = \frac{2}{m} [(|F_x| - F_f) \cdot (x_1' \cdot q^{2k} - x)] \end{cases} \quad (1.93)$$

Or, using the data

$$v_{(k,\leftarrow)}^2 = \frac{2}{m} \left[9 \cdot \left(\frac{21}{11} \cdot \left(\frac{9}{11} \right)^k - x \right) \right] \quad (1.94)$$

From the k^{th} run from the origin, analogous to (1.59), the dependence on the position of the square speed $v_{(k,\rightarrow)}^2$ can be written as

$$\begin{cases} v_{(k,\rightarrow)}^2 = \frac{2}{m} [(F_x + F_f) \cdot (x_k' - x)] \\ v_{(k,\rightarrow)}^2 = \frac{2}{m} [(F_x + F_f) \cdot (x_1' \cdot q^{2k} - x)] \end{cases} \quad (1.95)$$

Using given data

$$v_{(k,\rightarrow)}^2 = \frac{2}{m} \left[11 \cdot \left(\frac{21}{11} \cdot \left(\frac{9}{11} \right)^k - x \right) \right] \quad (1.96)$$

The evolution of the square of the speed as function on position is presented in the figure 1.10.

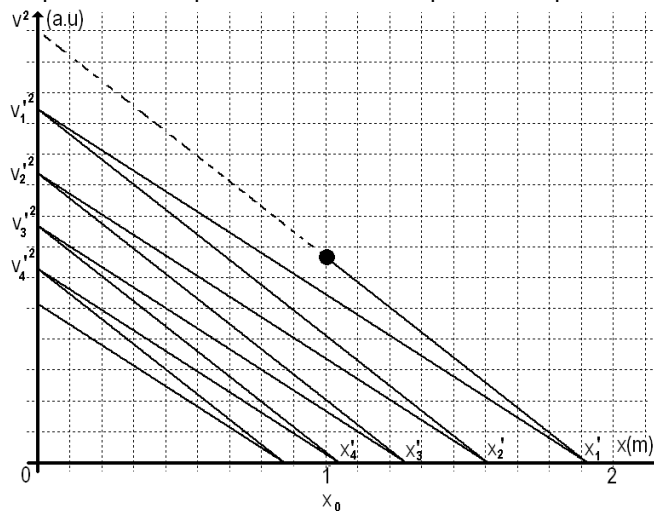

Figure 1.10

And the evolution of the speed as function of the position is presented in the figure 1.11.

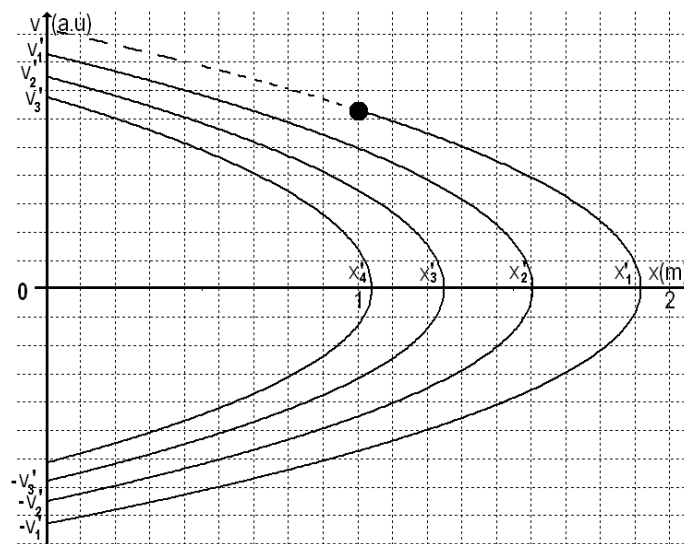

Figure 1.11

The sum of the geometrical progression (1.92) gives (after the doubling and then subtracting of the x_0) the total distance covered by the particle.



$$\sum_{k=1}^{\infty} x_k' = x_1' \frac{1}{1-q^2} \quad (1.97)$$

Considering (1.97), (1.71) and (1.72) it results

$$\sum_{k=1}^{\infty} x_k' = \frac{21}{2} m \quad (1.98)$$

The total distance covered by the particle is

$$\begin{cases} D = 2 \cdot \sum_{k=1}^{\infty} x_k' - x_0 \\ D = 20m \end{cases} \quad (1.99)$$

which allows us to find again the result (1.14).

Professor Delia DAVIDESCU, National Department of Evaluation and Examination–Ministry of Education and Research- Bucharest, Romania

Professor Adrian S.DAFINEI, PhD, Faculty of Physics – University of Bucharest, Romania

Electricity – Problem II (8 points)

Different kind of oscillation

Let's consider the electric circuit in the figure, for which $L_1 = 10 \text{ mH}$, $L_2 = 20 \text{ mH}$, $C_1 = 10 \text{ nF}$, $C_2 = 5 \text{ nF}$ and $R = 100 \text{ k}\Omega$. The switch K being closed the circuit is coupled with a source of alternating current. The current furnished by the source has constant intensity while the frequency of the current may be varied.

- Find the ratio of frequency f_m for which the active power in circuit has the maximum value P_m and the frequency difference $\Delta f = f_+ - f_-$ of the frequencies f_+ and f_- for which the active power in the circuit is half of the maximum power P_m .

The switch K is now open. In the moment t_0 immediately after the switch is open the intensities of the currents in the coils L_1 and L_2 are $i_{01} = 0,1 \text{ A}$ and $i_{02} = 0,2 \text{ A}$ (L_1 and L_2 the currents flow as in the figure); at the same moment, the potential difference on the capacitor with capacity C_1 is $u_0 = 40 \text{ V}$:

- Calculate the frequency of electromagnetic oscillation in $L_1 C_1 C_2 L_2$ circuit;
- Determine the intensity of the electric current in the AB conductor;
- Calculate the amplitude of the oscillation of the intensity of electric current in the coil L_1 .

Neglect the mutual induction of the coils, and the electric resistance of the conductors. Neglect the fast transition phenomena occurring when the switch is closed or opened.

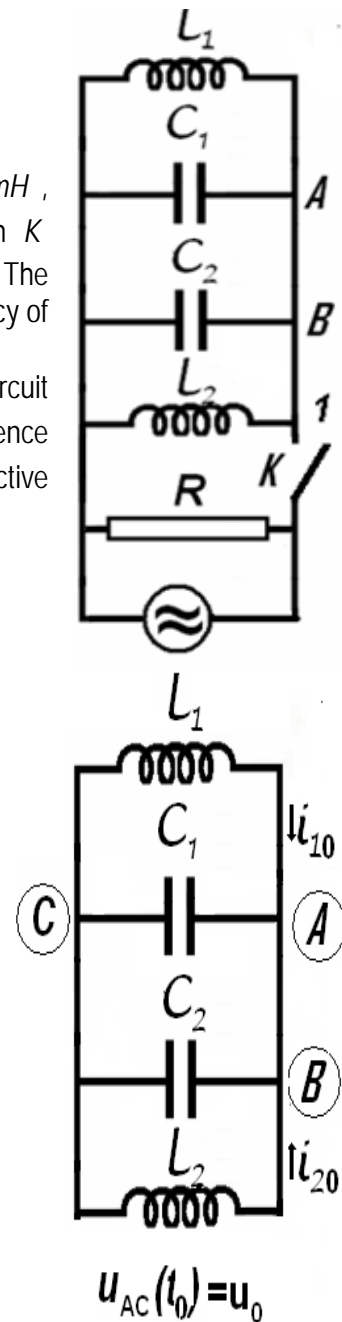

Problem II - Solution

a. As is very well known in the study of AC circuits using the formalism of complex numbers, a complex inductive reactance $\overline{X}_L = L \cdot \omega \cdot j$, ($j = \sqrt{-1}$) is attached to the inductance L - part of a circuit supplied with an alternative current having the pulsation ω .

Similar, a complex capacitive reactance $\overline{X}_C = -\frac{j}{C \cdot \omega}$ is attached to the capacity C .

A parallel circuit will be characterized by his complex admittance \overline{Y} . The admittance of the AC circuit represented in the figure is



$$\begin{cases} \bar{Y} = \frac{1}{R} + \frac{1}{L_1 \cdot \omega \cdot j} + \frac{1}{L_2 \cdot \omega \cdot j} - \frac{C_1 \cdot \omega}{j} - \frac{C_2 \cdot \omega}{j} \\ \bar{Y} = \frac{1}{R} + j \cdot \left[(C_1 + C_2) - \left(\frac{1}{L_1} + \frac{1}{L_2} \right) \right] \end{cases} \quad (2.1)$$

The circuit behave as if has a parallel equivalent capacity C

$$C = C_1 + C_2 \quad (2.2)$$

and a parallel equivalent inductance L

$$\begin{cases} \frac{1}{L} = \frac{1}{L_1} + \frac{1}{L_2} \\ L = \frac{L_1 L_2}{L_1 + L_2} \end{cases} \quad (2.3)$$

The complex admittance of the circuit may be written as

$$\bar{Y} = \frac{1}{R} + j \cdot \left(C \cdot \omega - \frac{1}{L \cdot \omega} \right) \quad (2.4)$$

and the complex impedance of the circuit will be

$$\begin{cases} \bar{Z} = \frac{1}{\bar{Y}} \\ \bar{Z} = \frac{\frac{1}{R} + j \cdot \left(\frac{1}{L \cdot \omega} - C \cdot \omega \right)}{\sqrt{\left(\frac{1}{R} \right)^2 + \left(C \cdot \omega - \frac{1}{L \cdot \omega} \right)^2}} \end{cases} \quad (2.5)$$

The impedance Z of the circuit, the inverse of the admittance of the circuit Y is the modulus of the complex impedance \bar{Z}

$$Z = |\bar{Z}| = \frac{1}{\sqrt{\left(\frac{1}{R} \right)^2 + \left(C \cdot \omega - \frac{1}{L \cdot \omega} \right)^2}} = \frac{1}{Y} \quad (2.6)$$

The constant current source supplying the circuit furnish a current having a momentary value $i(t)$

$$i(t) = I \cdot \sqrt{2} \cdot \sin(\omega \cdot t), \quad (2.7)$$

where I is the effective intensity (constant), of the current and ω is the current pulsation (that can vary) . The potential difference at the jacks of the circuit has the momentary value $u(t)$

$$u(t) = U \cdot \sqrt{2} \cdot \sin(\omega \cdot t + \varphi) \quad (2.8)$$

where U is the effective value of the tension and φ is the phase difference between tension and current.

The effective values of the current and tension obey the relation



$$U = I \cdot Z \quad (2.9)$$

The active power in the circuit is

$$P = \frac{U^2}{R} = \frac{Z^2 \cdot I^2}{R} \quad (2.10)$$

Because as in the enounce,

$$\begin{cases} I = \text{constant} \\ R = \text{constant} \end{cases} \quad (2.11)$$

the maximal active power is realized for the maximum value of the impedance that is the minimal value of the admittance .

The admittance

$$Y = \sqrt{\left(\frac{1}{R}\right)^2 + \left(C \cdot \omega - \frac{1}{L \cdot \omega}\right)^2} \quad (2.12)$$

has- as function of the pulsation ω - an „the smallest value”

$$Y_{\min} = \frac{1}{R} \quad (2.13)$$

for the pulsation

$$\omega_m = \frac{1}{\sqrt{L \cdot C}} \quad (2.14)$$

In this case

$$\left(C \cdot \omega - \frac{1}{L \cdot \omega}\right) = 0. \quad (2.15)$$

So, the minimal active power in the circuit has the value

$$P_m = R \cdot I^2 \quad (2.16)$$

and occurs in the situation of alternative current furnished by the source at the frequency f_m

$$f_m = \frac{1}{2\pi} \omega_m = \frac{1}{2\pi \cdot \sqrt{C \cdot L}} \quad (2.17)$$

To ensure that the active power is half of the maximum power it is necessary that

$$\begin{cases} P = \frac{1}{2} P_m \\ \frac{Z^2 \cdot I^2}{R} = \frac{1}{2} R \cdot I^2 \\ \frac{2}{R^2} = \frac{1}{Z^2} = Y^2 \end{cases} \quad (2.18)$$

That is



$$\begin{cases} \frac{2}{R^2} = \frac{1}{R^2} + \left(C \cdot \omega - \frac{1}{L \cdot \omega} \right)^2 \\ \pm \frac{1}{R} = C \cdot \omega - \frac{1}{L \cdot \omega} \end{cases} \quad (2.19)$$

The pulsation of the current ensuring an active power at half of the maximum power must satisfy one of the equations

$$\omega^2 \pm \frac{1}{R \cdot C} \omega - \frac{1}{L \cdot C} = 0 \quad (2.20)$$

The two second degree equation may furnish the four solutions

$$\omega = \pm \frac{1}{2R \cdot C} \pm \frac{1}{2} \sqrt{\left(\frac{1}{R \cdot C} \right)^2 + \frac{4}{L \cdot C}} \quad (2.21)$$

Because the pulsation is every time positive, and because

$$\sqrt{\left(\frac{1}{R \cdot C} \right)^2 + \frac{4}{L \cdot C}} > \frac{1}{R \cdot C} \quad (2.22)$$

the only two valid solutions are

$$\omega_{\pm} = \frac{1}{2} \sqrt{\left(\frac{1}{R \cdot C} \right)^2 + \frac{4}{L \cdot C}} \pm \frac{1}{2R \cdot C} \quad (2.23)$$

It exist two frequencies $f_{\pm} = \frac{1}{2\pi} \omega_{\pm}$ allowing to obtain in the circuit an active power representing half of the maximum power.

$$\begin{cases} f_{+} = \frac{1}{2\pi} \left(\frac{1}{2} \sqrt{\left(\frac{1}{R \cdot C} \right)^2 + \frac{4}{L \cdot C}} + \frac{1}{2R \cdot C} \right) \\ f_{-} = \frac{1}{2\pi} \left(\frac{1}{2} \sqrt{\left(\frac{1}{R \cdot C} \right)^2 + \frac{4}{L \cdot C}} - \frac{1}{2R \cdot C} \right) \end{cases} \quad (2.24)$$

The difference of these frequencies is

$$\Delta f = f_{+} - f_{-} = \frac{1}{2\pi} \frac{1}{R \cdot C} \quad (2.25)$$

the bandwidth of the circuit – the frequency interval around the resonance frequency having at the ends a signal representing $1/\sqrt{2}$ from the resonance signal. At the ends of the bandwidth the active power reduces at the half of his value at the resonance.

The asked ratio is

$$\begin{cases} \frac{f_m}{\Delta f} = \frac{R \cdot C}{\sqrt{L \cdot C}} = R \sqrt{\frac{C}{L}} \\ \frac{f_m}{\Delta f} = R \sqrt{\frac{(C_1 + C_2) \cdot (L_1 + L_2)}{L_1 \cdot L_2}} \end{cases} \quad (2.26)^*$$

Because

$$\begin{cases} C = 15 \text{ nF} \\ L = \frac{20}{3} \text{ mH} \end{cases}$$

it results that

$$\omega_m = 10^5 \text{ rad} \cdot \text{s}^{-1}$$

and

$$\frac{f_m}{\Delta f} = R \sqrt{\frac{C}{L}} = 100 \times 10^3 \cdot \sqrt{\frac{3 \cdot 15 \times 10^{-9}}{20 \times 10^{-3}}} = 150 \quad (2.27)$$

The (2.26) relation is the answer at the question a.

b. The fact that immediately after the source is detached it is a current in the coils, allow as to admit that currents depends on time will continue to flow through the coils.

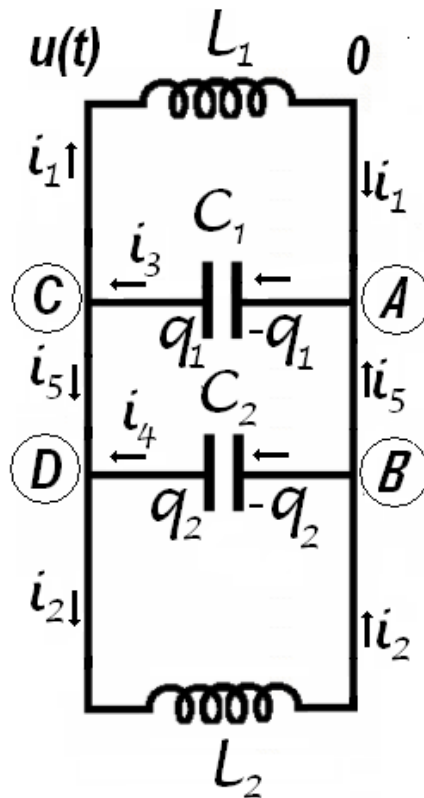

Figure 2.1

The capacitors will be charged with charges variable in time. The variation of the charges of the capacitors will results in currents flowing through the conductors linking the capacitors in the circuit. The momentary tension on the jacks of the coils and capacitors – identical for all elements in circuit – is also dependent on time. Let's admit that the electrical potential of the points C and D is $u(t)$ and the



potential of the points A and B is zero. If through the inductance L_1 passes the variable current having the momentary value $i_1(t)$, the relation between the current and potentials is

$$u(t) - L_1 \frac{di_1}{dt} = 0 \quad (2.28)$$

The current passing through the second inductance $i_2(t)$ has the expression,

$$u(t) - L_2 \frac{di_2}{dt} = 0 \quad (2.29)$$

If on the positive plate of the capacitor having the capacity C_1 is stocked the charge $q_1(t)$, then at the jacks of the capacitor the electrical tension is $u(t)$ and

$$q_1 = C_1 \cdot u \quad (2.30)$$

Deriving this relation it results

$$\frac{dq_1}{dt} = C_1 \cdot \frac{du}{dt} \quad (2.31)$$

But

$$\frac{dq_1}{dt} = -i_3 \quad (2.32)$$

because the electrical current appears because of the diminishing of the electrical charge on capacitor plate. Consequently

$$i_3 = -C_1 \cdot \frac{du}{dt} \quad (2.33)$$

Analogous, for the other capacitor,

$$i_4 = -C_4 \cdot \frac{du}{dt} \quad (2.34)$$

Considering all obtained results

$$\begin{cases} \frac{di_1}{dt} = \frac{u}{L_1} \\ \frac{di_2}{dt} = \frac{u}{L_2} \end{cases} \quad (2.35)$$

respectively

$$\begin{cases} \frac{di_3}{dt} = -C_1 \frac{d^2u}{dt^2} \\ \frac{di_4}{dt} = C_2 \frac{d^2u}{dt^2} \end{cases} \quad (2.36)$$

Denoting $i_5(t)$ the momentary intensity of the current flowing from point B to the point A , then the same momentary intensity has the current through the points C and D . For the point A the Kirchhoff rule of the currents gives



$$i_1 + i_5 = i_3 \quad (2.37)$$

For B point the same rule produces

$$i_4 + i_5 = i_2 \quad (2.38)$$

Considering (2.37) and (2.38) results

$$i_1 - i_3 = i_4 - i_2 \quad (2.39)$$

and deriving

$$\frac{di_1}{dt} - \frac{di_3}{dt} = \frac{di_4}{dt} - \frac{di_2}{dt} \quad (2.40)$$

that is

$$\begin{cases} -\frac{u}{L_1} - \frac{u}{L_2} = C_1 \frac{d^2 u}{dt^2} + C_2 \frac{d^2 u}{dt^2} \\ -u \cdot \left(\frac{1}{L_1} + \frac{1}{L_2} \right) = \frac{d^2 u}{dt^2} \cdot (C_1 + C_2) \end{cases} \quad (2.41)$$

Using the symbols defined above

$$\begin{cases} -\frac{u}{L} = \frac{d^2 u}{dt^2} \cdot C \\ \ddot{u} + \frac{1}{LC} u = 0 \end{cases} \quad (2.42)$$

Because the tension obeys the relation above, it must have a harmonic dependence on time

$$u(t) = A \cdot \sin(\omega \cdot t + \delta) \quad (2.43)$$

The pulsation of the tension is

$$\omega = \frac{1}{\sqrt{L \cdot C}} \quad (2.44)$$

Taking into account the relations (2.43) and (2.36) it results that

$$\begin{cases} i_3 = -C_1 \frac{d}{dt} (A \cdot \sin(\omega \cdot t + \delta)) = -C_1 \cdot A \cdot \omega \cdot \cos(\omega \cdot t + \delta) \\ i_4 = -C_2 \frac{d}{dt} (A \cdot \sin(\omega \cdot t + \delta)) = -C_2 \cdot A \cdot \omega \cdot \cos(\omega \cdot t + \delta) \end{cases} \quad (2.45)$$

and

$$\begin{cases} \frac{di_1}{dt} = \frac{u}{L_1} = \frac{1}{L_1} \cdot A \cdot \sin(\omega \cdot t + \delta) \\ \frac{di_2}{dt} = \frac{u}{L_2} = \frac{1}{L_2} \cdot A \cdot \sin(\omega \cdot t + \delta) \end{cases} \quad (2.46)$$

It results that



$$\begin{cases} i_1 = \frac{1}{L_1 \cdot \omega} \cdot A \cdot \cos(\omega \cdot t + \delta) + M \\ i_2 = \frac{1}{L_2 \cdot \omega} \cdot A \cdot \cos(\omega \cdot t + \delta) + N \end{cases} \quad (2.47)$$

In the expression above, A , M , N and δ are constants that must be determined using initially conditions. It is remarkable that the currents through capacitors are sinusoidal but the currents through the coils are the sum of sinusoidal and constant currents.

In the first moment

$$\begin{cases} u(0) = u_0 = 40V \\ i_1(0) = i_{01} = 0,1A \\ i_2(0) = i_{02} = 0,2A \end{cases} \quad (2.48)$$

Because the values of the inductances and capacities are

$$\begin{cases} L_1 = 0,01H \\ L_2 = 0,02H \\ C_1 = 10nF \\ C_2 = 5nF \end{cases} \quad (2.49)$$

the equivalent inductance and capacity is

$$\begin{cases} \frac{1}{L} = \frac{1}{L_1} + \frac{1}{L_2} \\ L = \frac{L_1 \cdot L_2}{L_1 + L_2} \\ L = \frac{2 \times 10^{-4}}{3 \times 10^{-2}} H = \frac{1}{150} H \end{cases} \quad (2.50)$$

respectively

$$\begin{cases} C = C_1 + C_2 \\ C = 15nF \end{cases} \quad (2.51)$$

From (2.44) results

$$\omega = \frac{1}{\sqrt{\frac{1}{150} \cdot 15 \times 10^{-9}}} = 10^5 \text{ rad} \cdot \text{s}^{-1} \quad (2.52)^*$$

The value of the pulsation allows calculating the value of the requested frequency **b**. This frequency has the value f

$$f = \frac{\omega}{2\pi} = \frac{10^5}{2\pi} \text{ Hz} \quad (2.53)^*$$

c. If the momentary tension on circuit is like in (2.43), one may write



$$\begin{cases} u(0) = A \cdot \sin(\delta) = u_0 \\ \sin(\delta) = \frac{u_0}{A} \end{cases} \quad (2.54)$$

From the currents (2.47) is possible to write

$$\begin{cases} i_{01} = \frac{1}{L_1 \cdot \omega} \cdot A \cdot \cos(\delta) + M \\ i_{02} = \frac{1}{L_2 \cdot \omega} \cdot A \cdot \cos(\delta) + N \end{cases} \quad (2.55)$$

On the other side is possible to express (2.39) as

$$\begin{cases} i_1 - i_3 = i_4 - i_2 \\ \frac{1}{L_1 \cdot \omega} \cdot A \cdot \cos(\omega \cdot t + \delta) + M + C_1 \cdot A \cdot \omega \cdot \cos(\omega \cdot t + \delta) = \\ -C_2 \cdot A \cdot \omega \cdot \cos(\omega \cdot t + \delta) - \frac{1}{L_2 \cdot \omega} \cdot A \cdot \cos(\omega \cdot t + \delta) - N \end{cases} \quad (2.56)$$

An identity as

$$A \cdot \cos \alpha + B \equiv C \cdot \cos \alpha + D \quad (2.57)$$

is valuable for any value of the argument α only if

$$\begin{cases} A = C \\ B = D \end{cases} \quad (2.58)$$

Considering (2.58), from (2.56) it results

$$\begin{cases} M + N = 0 \\ A \cdot \omega \cdot (C_1 + C_2) = -\frac{A}{\omega} \cdot \left(\frac{1}{L_1} + \frac{1}{L_2} \right) \end{cases} \quad (2.59)$$

For the last equation it results that the circuit oscillate with the pulsation in the relation (2.44)

Adding relations (2.55) and considering (2.54) and (2.59) results that

$$\begin{cases} i_{01} + i_{02} = A \cdot \cos(\delta) \cdot \frac{1}{\omega} \cdot \left(\frac{1}{L_1} + \frac{1}{L_1} \right) \\ A = \frac{i_{01} + i_{02}}{\cos(\delta) \cdot \frac{1}{\omega} \cdot \left(\frac{1}{L_1} + \frac{1}{L_1} \right)} \\ \cos \delta = \frac{i_{01} + i_{02}}{A \cdot \frac{1}{\omega} \cdot \left(\frac{1}{L_1} + \frac{1}{L_1} \right)} \\ \cos \delta = \frac{(i_{01} + i_{02}) \cdot L \cdot \omega}{A} \end{cases} \quad (2.60)$$



The numerical value of the amplitude of the electrical tension results by summing the last relations from (2.54) and (2.60)

$$\begin{cases} \sin(\delta) = \frac{u_0}{A} \\ \cos \delta = \frac{(i_{01} + i_{02}) \cdot L \cdot \omega}{A} \\ (\cos(\delta))^2 + (\sin(\delta))^2 = 1 \\ \left(\frac{u_0}{A}\right)^2 + \left(\frac{(i_{01} + i_{02}) \cdot L \cdot \omega}{A}\right)^2 = 1 \\ A = \sqrt{(u_0)^2 + ((i_{01} + i_{02}) \cdot L \cdot \omega)^2} \end{cases} \quad (2.61)$$

The numerical value of the electrical tension on the jacks of the circuit is

$$\begin{cases} A = \sqrt{(40)^2 + \left((0,3) \cdot \frac{1}{150} \cdot 10^5 \right)^2} \\ A = \sqrt{(40)^2 + (200)^2} = 40\sqrt{26} \text{ V} \end{cases} \quad (2.62)$$

And consequently from (2.54) results

$$\begin{cases} \sin(\delta) = \frac{u_0}{A} \\ \sin(\delta) = \frac{40}{40\sqrt{26}} = \frac{1}{\sqrt{26}} \end{cases} \quad (2.63)$$

and

$$\cos(\delta) = \frac{5}{\sqrt{26}} \quad (2.64)$$

Also

$$\begin{cases} \operatorname{tg}(\delta) = \frac{1}{5} \\ \delta = \operatorname{arctg}(1/5) \end{cases} \quad (2.65)$$

From (2.55)

$$\begin{cases} M = i_{01} - \frac{1}{L_1 \cdot \omega} \cdot A \cdot \cos(\delta) \\ N = i_{02} - \frac{1}{L_2 \cdot \omega} \cdot A \cdot \cos(\delta) \end{cases} \quad (2.66)$$

the corresponding numerical values are

$$\begin{cases} M = \left(0,1 - \frac{1}{0,01 \cdot 10^5} \cdot 40\sqrt{26} \cdot \frac{5}{\sqrt{26}} \right) A = -0,1 A \\ N = \left(0,2 - \frac{1}{0,02 \cdot 10^5} \cdot 40\sqrt{26} \cdot \frac{5}{\sqrt{26}} \right) A = 0,1 A \end{cases} \quad (2.67)^*$$

The relations (2.47) becomes

$$\begin{cases} i_1 = \left(\frac{4\sqrt{26}}{100} \cdot \cos(10^5 \cdot t + \arctg(1/5)) - 0,1 \right) A = \tilde{i}_1 - I_0 \\ i_2 = \left(\frac{2\sqrt{26}}{100} \cdot \cos(10^5 \cdot t + \arctg(1/5)) + 0,1 \right) A = \tilde{i}_2 + I_0 \end{cases} \quad (2.68)$$

The currents through the coils are the superposition of sinusoidal currents having different amplitudes and a direct current passing only through the coils. This direct current has the constant value

$$I_0 = 0,1 A \quad (2.69)^*$$

as in the figure 2.2.

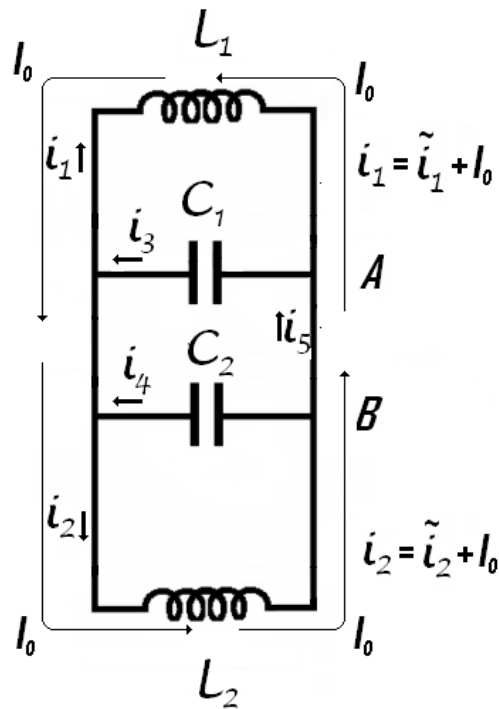

Figure 2.2

The alternative currents through the coils has the expressions

$$\begin{cases} \tilde{i}_1 = \left(\frac{4\sqrt{26}}{100} \cdot \cos(10^5 \cdot t + \arctg(1/5)) \right) A \\ \tilde{i}_2 = \left(\frac{2\sqrt{26}}{100} \cdot \cos(10^5 \cdot t + \arctg(1/5)) \right) A \end{cases} \quad (2.70)$$



The currents through the capacitors has the forms

$$\begin{cases} i_3 = (-10 \times 10^{-4} \cdot 40\sqrt{26} \cdot \cos(10^5 \cdot t + \arctg(1/5)))A \\ i_3 = \left(-\frac{4\sqrt{26}}{100} \cos(10^5 \cdot t + \arctg(1/5))\right)A \\ i_4 = (-5 \times 10^{-4} \cdot 40\sqrt{26} \cdot \cos(10^5 \cdot t + \arctg(1/5)))A \\ i_4 = \left(-\frac{2\sqrt{26}}{100} \cos(10^5 \cdot t + \arctg(1/5))\right)A \end{cases} \quad (2.71)$$

The current i_5 has the expression

$$\begin{cases} i_5 = i_3 - i_1 \\ i_5 = \left(-\frac{8\sqrt{26}}{100} \cos(10^5 \cdot t + \arctg(1/5)) + 0,1\right)A \end{cases} \quad (2.72)$$

The value of the intensity of i_5 current is the answer from the question c.

The initial value of this current is

$$i_5 = \left(-\frac{8\sqrt{26}}{100} \frac{5}{\sqrt{26}} + 0,1\right)A = -0,3A \quad (2.73)^*$$

d. The amplitude of the current through the inductance L_1 is

$$\max(\tilde{i}_1) = \max\left(\frac{4\sqrt{26}}{100} \cdot \cos(10^5 \cdot t + \arctg(1/5))A\right) = \frac{4\sqrt{26}}{100}A \approx 0,2A \quad (2.74)^*$$

representing the answer at the question d.

Professor Delia DAVIDESCU, National Department of Evaluation and Examination—Ministry of Education and Research— Bucharest, Romania
Professor Adrian S.DAFINEI, PhD, Faculty of Physics – University of Bucharest, Romania

Optics – Problem III (7points)

Prisms

Two dispersive prisms having apex angles $\hat{A}_1 = 60^\circ$ and $\hat{A}_2 = 30^\circ$ are glued as in the figure ($\hat{C} = 90^\circ$). The dependences of refraction indexes of the prisms on the wavelength are given by the relations

$$n_1(\lambda) = a_1 + \frac{b_1}{\lambda^2};$$

$$n_2(\lambda) = a_2 + \frac{b_2}{\lambda^2}$$

were

$$a_1 = 1,1, \quad b_1 = 1 \cdot 10^5 \text{ nm}^2, \quad a_2 = 1,3, \quad b_2 = 5 \cdot 10^4 \text{ nm}^2.$$

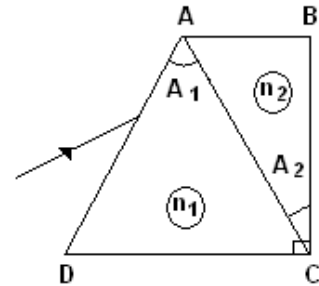

- Determine the wavelength λ_0 of the incident radiation that pass through the prisms without refraction on AC face at any incident angle; determine the corresponding refraction indexes of the prisms.
- Draw the ray path in the system of prisms for three different radiations λ_{red} , λ_0 , λ_{violet} incident on the system at the same angle.
- Determine the minimum deviation angle in the system for a ray having the wavelength λ_0 .
- Calculate the wavelength of the ray that penetrates and exits the system along directions parallel to DC .

Problem III - Solution

- The ray with the wavelength λ_0 pass trough the prisms system without refraction on AC face at any angle of incidence if :

$$n_1(\lambda_0) = n_2(\lambda_0)$$

Because the dependence of refraction indexes of prisms on wavelength has the form :

$$n_1(\lambda) = a_1 + \frac{b_1}{\lambda^2} \quad (3.1)$$

$$n_2(\lambda) = a_2 + \frac{b_2}{\lambda^2} \quad (3.2)$$

The relation (3.1) becomes:

$$a_1 + \frac{b_1}{\lambda_0^2} = a_2 + \frac{b_2}{\lambda_0^2} \quad (3.3)$$

The wavelength λ_0 has correspondingly the form:

$$\lambda_0 = \sqrt{\frac{b_1 - b_2}{a_2 - a_1}} \quad (3.4)$$

Substituting the furnished numerical values

$$\lambda_0 = 500 \text{ nm} \quad (3.5)$$

The corresponding common value of indexes of refraction of prisms for the radiation with the wavelength λ_0 is:

$$n_1(\lambda_0) = n_2(\lambda_0) = 1,5 \tag{3.6}$$

The relations (3.6) and (3.7) represent the answers of question a.

b. For the rays with different wavelength (λ_{red} , λ_0 , λ_{violet}) having the same incidence angle on first prism, the paths are illustrated in the figure 1.1.

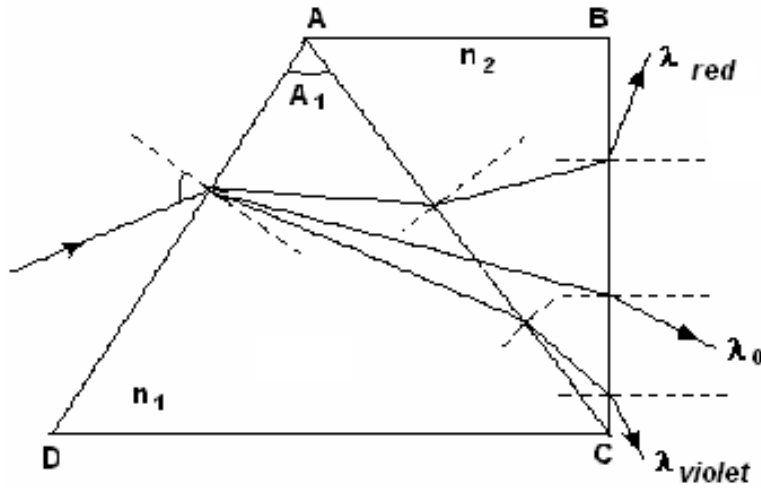

Figure 3.1

The draw illustrated in the figure 1.1 represents the answer of question b.

c. In the figure 1.2 is presented the path of ray with wavelength λ_0 at minimum deviation (the angle between the direction of incidence of ray and the direction of emerging ray is minimal).

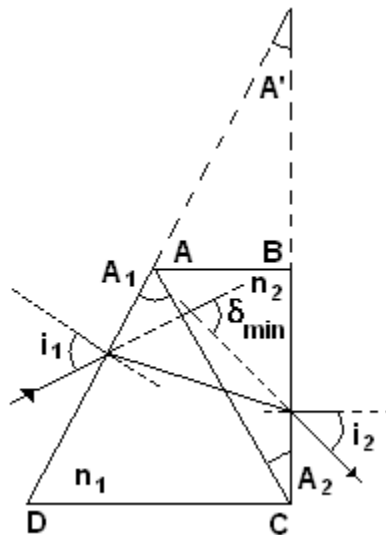

Figure 3.2

In this situation

$$n_1(\lambda_0) = n_2(\lambda_0) = \frac{\sin \frac{\delta_{\min} + A'}{2}}{\sin \frac{A'}{2}} \quad (3.7)$$

where

$$m(\hat{A}') = 30^\circ,$$

as in the figure 1.1

Substituting in (3.8) the values of refraction indexes the result is

$$\sin \frac{\delta_{\min} + A'}{2} = \frac{3}{2} \cdot \sin \frac{A'}{2} \quad (3.8)$$

or

$$\delta_{\min} = 2 \arcsin \left(\frac{3}{2} \cdot \sin \frac{A'}{2} \right) - \frac{A'}{2} \quad (3.9)$$

Numerically

$$\delta_{\min} \cong 30,7^\circ \quad (3.10)$$

The relation (3.11) represents the answer of question c.

d. Using the figure 1.3 the refraction law on the AD face is

$$\sin i_1 = n_1 \cdot \sin r_1 \quad (3.11)$$

The refraction law on the AC face is

$$n_1 \cdot \sin r_1' = n_2 \cdot \sin r_2 \quad (3.12)$$

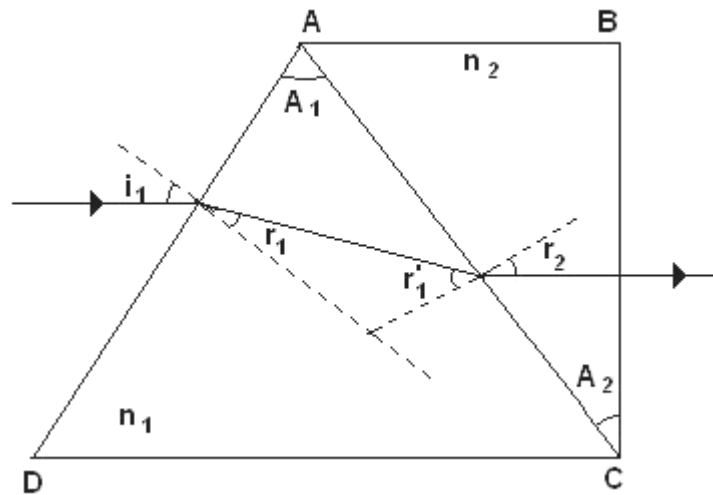

Figure 3.3

As it can be seen in the figure 1.3

$$r_2 = A_2 \quad (3.13)$$

and

$$i_1 = 30^\circ \quad (3.14)$$

Also,

$$r_1 + r_1' = A_1 \quad (3.15)$$

Substituting (3.16) and (3.14) in (3.13) it results



$$n_1 \cdot \sin(A_1 - r_1) = n_2 \cdot \sin A_2 \quad (3.16)$$

or

$$n_1 \cdot (\sin A_1 \cdot \cos r_1 - \sin r_1 \cdot \cos A_1) = n_2 \cdot \sin A_2 \quad (3.17)$$

Because of (3.12) and (3.15) it results that

$$\sin r_1 = \frac{1}{2n_1} \quad (3.18)$$

and

$$\cos r_1 = \frac{1}{2n_1} \sqrt{4n_1^2 - 1} \quad (3.19)$$

Putting together the last three relations it results

$$\sqrt{4n_1^2 - 1} = \frac{2n_2 \cdot \sin A_2 + \cos A_1}{\sin A_1} \quad (3.20)$$

Because

$$\hat{A}_1 = 60^\circ$$

and

$$\hat{A}_2 = 30^\circ$$

relation (3.21) can be written as

$$\sqrt{4n_1^2 - 1} = \frac{2n_2 + 1}{\sqrt{3}} \quad (3.21)$$

or

$$3 \cdot n_1^2 = 1 + n_2 + n_2^2 \quad (3.22)$$

Considering the relations (3.1), (3.2) and (3.23) and operating all calculus it results:

$$\lambda^4 \cdot (3a_1^2 - a_2^2 - a_2 - 1) + (6a_1b_1 - b_2 - 2a_2b_2) \cdot \lambda^2 + 3b_1^2 - b_2^2 = 0 \quad (3.23)$$

Solving the equation (3.24) one determine the wavelength λ of the ray that enter the prisms system having the direction parallel with DC and emerges the prism system having the direction again parallel with DC . That is

$$\lambda = 1194 \text{ nm} \quad (3.24)$$

or

$$\lambda \cong 1,2 \mu\text{m} \quad (3.25)$$

The relation (3.26) represents the answer of question d.

Professor Delia DAVIȚESCU, National Department of Evaluation and Examination—Ministry of Education and Research- Bucharest, Romania

Professor Adrian S. DAFINEI, PhD, Faculty of Physics – University of Bucharest, Romania

Atoms - Problem IV (7 points)

Compton scattering

A photon of wavelength λ_i is scattered by a moving, free electron. As a result the electron stops and the resulting photon of wavelength λ_0 scattered at an angle $\theta = 60^\circ$ with respect to the direction of the incident photon, is again scattered by a second free electron at rest. In this second scattering process a photon with wavelength of $\lambda_f = 1,25 \times 10^{-10} \text{ m}$ emerges at an angle $\theta = 60^\circ$ with respect to the direction of the photon of wavelength λ_0 . Find the de Broglie wavelength for the first electron before the interaction. The following constants are known:

$h = 6,6 \times 10^{-34} \text{ J} \cdot \text{s}$ - Planck's constant

$m = 9,1 \times 10^{-31} \text{ kg}$ - mass of the electron

$c = 3,0 \times 10^8 \text{ m/s}$ - speed of light in vacuum

Problem III - Solution

The purpose of the problem is to calculate the values of the speed, momentum and wavelength of the first electron.

To characterize the photons the following notation are used:

Table 4.1

	initial photon	photon – after the first scattering	final photon
momentum	\vec{p}_i	\vec{p}_0	\vec{p}_f
energy	E_i	E_0	E_f
wavelength	λ_i	λ_0	λ_f

To characterize the electrons one uses

Table 4.2

	first electron before collision	first electron after collision	second electron before collision	Second electron after collision
momentum	\vec{p}_{1e}	0	0	\vec{p}_{2e}
energy	E_{1e}	E_{0e}	E_{0e}	E_{2e}
speed	\vec{v}_{1e}	0	0	\vec{v}_{2e}

The image in figure 4.1 presents the situation before the first scattering of photon.

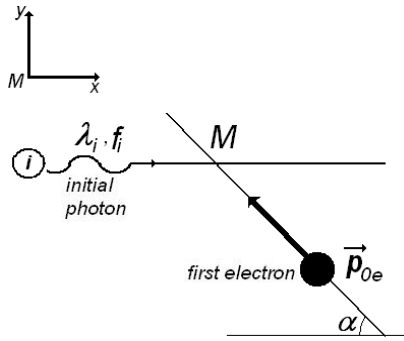

Figure 4.1

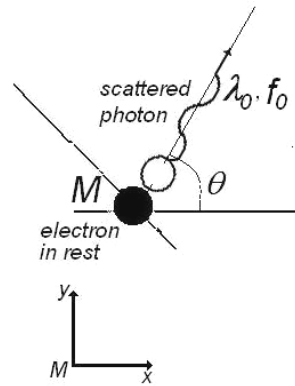

Figure 4.2

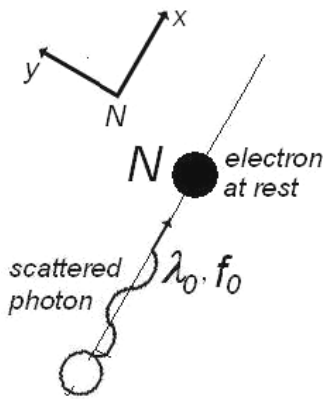

Figure 4.3

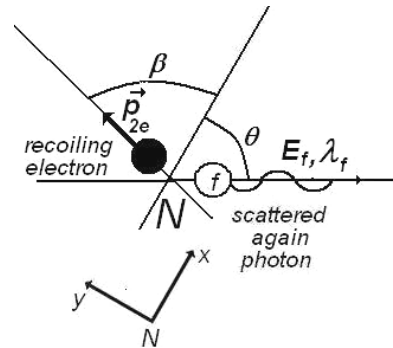

Figure 4.4

To characterize the initial photon we will use his momentum \vec{p}_i and his energy E_i

$$\begin{cases} \vec{p}_i = \frac{h}{\lambda_i} = \frac{h \cdot f_i}{c} \\ E_i = h \cdot f_i \end{cases} \quad (4.1)$$

$$f_i = \frac{c}{\lambda_i} \quad (4.2)$$

is the frequency of initial photon.

For initial, free electron in motion the momentum \vec{p}_{oe} and the energy E_{oe} are

$$\begin{cases} \vec{P}_{oe} = m \cdot \vec{v}_{1e} = \frac{m_0 \cdot \vec{v}_{1e}}{\sqrt{1-\beta^2}} \\ E_{oe} = m \cdot c^2 = \frac{m_0 \cdot c^2}{\sqrt{1-\beta^2}} \end{cases} \quad (4.3)$$

where m_0 is the rest mass of electron and m is the mass of moving electron. As usual, $\beta = \frac{v_{1e}}{c}$.

De Broglie wavelength of the first electron is



$$\lambda_{oe} = \frac{h}{p_{0e}} = \frac{h \cdot \sqrt{1 - \beta^2}}{m_0 \cdot v_{1e}}$$

The situation after the scattering of photon is described in the figure 4.2.

To characterize the scattered photon we will use his momentum \vec{p}_0 and his energy E_0

$$\begin{cases} \vec{p}_0 = \frac{h}{\lambda_0} = \frac{h \cdot f_0}{c} \\ E_0 = h \cdot f_0 \end{cases} \quad (4.4)$$

where

$$f_0 = \frac{c}{\lambda_0} \quad (4.5)$$

is the frequency of scattered photon.

The magnitude of momentum of the electron (that remains in rest) after the scattering is zero; his energy is E_{1e} . The mass of electron after collision is m_0 - the rest mass of electron at rest.

So,

$$E_{1e} = m_0 \cdot c^2$$

To determine the moment of the first moving electron, one can write the principles of conservation of moments and energy. That is

$$\vec{p}_i + \vec{p}_{0e} = \vec{p}_0 \quad (4.6)$$

and

$$E_i + E_{0e} = E_0 + E_{1e} \quad (4.7)$$

The conservation of moment on Ox direction is written as

$$\frac{h \cdot f_i}{c} + m \cdot v_{1e} \cdot \cos \alpha = \frac{h \cdot f_0}{c} \cos \theta \quad (4.8)$$

and the conservation of moment on Oy is

$$m \cdot v_{1e} \cdot \sin \alpha = \frac{h \cdot f_0}{c} \sin \theta \quad (4.9)$$

To eliminate α , the last two equation must be written again as

$$\begin{cases} (m \cdot v_{1e} \cdot \cos \alpha)^2 = \frac{h^2}{c^2} (f_0 \cdot \cos \theta - f_i)^2 \\ (m \cdot v_{1e} \cdot \sin \alpha)^2 = \left(\frac{h \cdot f_0}{c} \sin \theta \right)^2 \end{cases} \quad (4.10)$$

and then added.

The result is

$$m^2 \cdot v_{1e}^2 = \frac{h^2}{c^2} (f_0^2 + f_i^2 - 2f_0 \cdot f_i \cdot \cos \theta) \quad (4.11)$$

or



$$\frac{m_0^2 \cdot c^2}{1 - \left(\frac{v_{1e}}{c}\right)^2} \cdot v_{1e}^2 = h^2 \cdot (f_0^2 + f_1^2 - 2f_0 \cdot f_1 \cdot \cos\theta) \quad (4.12)$$

The conservation of energy (4.7) can be written again as

$$m \cdot c^2 + h \cdot f_1 = m_0 \cdot c^2 + h \cdot f_0 \quad (4.13)$$

or

$$\frac{m_0 \cdot c^2}{\sqrt{1 - \left(\frac{v_{1e}}{c}\right)^2}} = m_0 \cdot c^2 + h \cdot (f_0 - f_1) \quad (4.14)$$

Squaring the last relation results

$$\frac{m_0^2 \cdot c^4}{1 - \left(\frac{v_{1e}}{c}\right)^2} = m_0^2 \cdot c^4 + h^2 \cdot (f_0 - f_1)^2 + m_0 \cdot h \cdot c^2 \cdot (f_0 - f_1) \quad (4.15)$$

Subtracting (4.12) from (4.15) the result is

$$2m_0 \cdot c^2 \cdot h \cdot (f_0 - f_1) + 2h^2 \cdot f_1 \cdot f_0 \cdot \cos\theta - 2h^2 \cdot f_1 \cdot f_0 = 0 \quad (4.16)$$

or

$$\frac{h}{m_0 \cdot c} (1 - \cos\theta) = \frac{c}{f_1} - \frac{c}{f_0} \quad (4.17)$$

Using

$$\Lambda = \frac{h}{m_0 \cdot c} \quad (4.18)$$

the relation (4.17) becomes

$$\Lambda \cdot (1 - \cos\theta) = \lambda_i - \lambda_0 \quad (4.19)$$

The wavelength of scattered photon is

$$\lambda_0 = \lambda_i - \Lambda \cdot (1 - \cos\theta) \quad (4.20)$$

shorter than the wavelength of initial photon and consequently the energy of scattered photon is greater than the energy of initial photon.

$$\begin{cases} \lambda_i < \lambda_0 \\ E_i > E_0 \end{cases} \quad (4.21)$$

Let's analyze now the second collision process that occurs in point N . To study that, let's consider a new referential having Ox direction on the direction of the photon scattered after the first collision.

The figure 4.3 presents the situation before the second collision and the figure 4.4 presents the situation after this scattering process. The conservation principle for moment in the scattering process gives

$$\begin{cases} \frac{h}{\lambda_0} = \frac{h}{\lambda_f} \cos \theta + m \cdot v_{2e} \cdot \cos \beta \\ \frac{h}{\lambda_f} \sin \theta - m \cdot v_{2e} \cdot \sin \beta = 0 \end{cases} \quad (4.22)$$

To eliminate the unknown angle β must square and then add the equations (4.22)

That is

$$\begin{cases} \left(\frac{h}{\lambda_0} - \frac{h}{\lambda_f} \cos \theta \right)^2 = (m \cdot v_{2e} \cdot \cos \beta)^2 \\ \left(\frac{h}{\lambda_f} \sin \theta \right)^2 = (m \cdot v_{2e} \cdot \sin \beta)^2 \end{cases} \quad (4.23)$$

or

$$\left(\frac{h}{\lambda_f} \right)^2 + \left(\frac{h}{\lambda_0} \right)^2 - \frac{2 \cdot h^2}{\lambda_0 \cdot \lambda_f} \cos \theta = (m \cdot v_{2e})^2 \quad (4.24)$$

The conservation principle of energy in the second scattering process gives

$$\frac{h \cdot c}{\lambda_0} + m_0 \cdot c^2 = \frac{h \cdot c}{\lambda_f} + m \cdot c^2 \quad (4.25)$$

(4.24) and (4.25) gives

$$\frac{h^2 \cdot c^2}{\lambda_f^2} + \frac{h^2 \cdot c^2}{\lambda_0^2} - \frac{2 \cdot h^2 \cdot c^2}{\lambda_0 \cdot \lambda_f} \cos \theta = m^2 \cdot c^2 \cdot v_{2e}^2 \quad (4.26)$$

and

$$h^2 \cdot c^2 \cdot \left(\frac{1}{\lambda_f} - \frac{1}{\lambda_0} \right)^2 + m_0^2 \cdot c^4 + 2h \cdot c^3 \cdot m_0 \cdot \left(\frac{1}{\lambda_f} - \frac{1}{\lambda_0} \right) = m^2 \cdot c^4 \quad (4.27)$$

Subtracting (4.26) from (1.27), one obtain

$$\begin{cases} \frac{h}{m_0 \cdot c} \cdot (1 - \cos \theta) = \lambda_f - \lambda_0 \\ \lambda_f - \lambda_0 = \Lambda \cdot (1 - \cos \theta) \end{cases} \quad (4.28)$$

That is

$$\begin{cases} \lambda_f > \lambda_0 \\ E_f < E_0 \end{cases} \quad (4.29)$$

Because the value of λ_f is known and Λ can be calculated as

$$\begin{cases} \lambda_f = 1,25 \times 10^{-10} \text{ m} \\ \Lambda = \frac{6,6 \times 10^{-34}}{9,1 \times 10^{-31} \cdot 3 \times 10^8} \text{ m} = 2,41 \times 10^{-12} \text{ m} = 0,02 \times 10^{-10} \text{ m} \end{cases} \quad (4.30)$$

the value of wavelength of photon before the second scattering is

$$\lambda_0 = 1,23 \times 10^{-10} \text{ m} \quad (4.31)$$

Comparing (4.28) written as:

$$\lambda_f = \lambda_0 + \Lambda \cdot (1 - \cos \theta) \quad (4.32)$$

and (4.20) written as

$$\lambda_i = \lambda_0 + \Lambda \cdot (1 - \cos \theta) \quad (4.33)$$

clearly results

$$\lambda_i = \lambda_f \quad (4.34)$$

The energy of the double scattered photon is the same as the energy of initial photon. The direction of "final photon" is the same as the direction of "initial" photon. Concluding, the final photon is identical with the initial photon. The result is expected because of the symmetry of the processes.

Extending the symmetry analyze on electrons, the first moving electron that collides the initial photon and after that remains at rest, must have the same momentum and energy as the second electron after the collision – because this second electron is at rest before the collision.

That is

$$\begin{cases} \vec{p}_{1e} = \vec{p}_{2e} \\ E_{1e} = E_{2e} \end{cases} \quad (4.35)$$

Taking into account (4.24), the moment of final electron is

$$p_{2e} = h \sqrt{\frac{1}{\lambda_f^2} + \frac{1}{(\lambda_f - \Lambda(1 - \cos \theta))^2} - \frac{2 \cdot \cos \theta}{\lambda_f \cdot (\lambda_f - \Lambda(1 - \cos \theta))}} \quad (4.36)$$

The de Broglie wavelength of second electron after scattering (and of first electron before scattering) is

$$\lambda_{1e} = \lambda_{2e} = 1 / \left(\sqrt{\frac{1}{\lambda_f^2} + \frac{1}{(\lambda_f - \Lambda(1 - \cos \theta))^2} - \frac{2 \cdot \cos \theta}{\lambda_f \cdot (\lambda_f - \Lambda(1 - \cos \theta))}} \right) \quad (4.37)$$

Numerical value of this wavelength is

$$\lambda_{1e} = \lambda_{2e} = 1,24 \times 10^{-10} \text{ m} \quad (4.38)$$

Professor Delia DĂVIȚEȘCU, National Department of Evaluation and Examination – Ministry of Education and Research – Bucharest, Romania

Professor Adrian S. DĂFINEI, PhD, Faculty of Physics – University of Bucharest, Romania



IPhO's LOGO – Problem V

The Logo of the International Physics Olympiad is represented in the figure below.

The figure presents the phenomenon of the curving of the trajectory of a jet of fluid around the shape of a cylindrical surface. The trajectory of fluid is not like the expected dashed line but as the circular solid line.

Qualitatively explain this phenomenon (first observed by Romanian engineer Henry Coanda in 1936).

This problem will be not considered in the general score of the Olympiad. The best solution will be awarded a special prize.



Figure 5.1

Problem V - Solution

Suppose a fluid is in a recipient at a constant pressure. If a thin jet of fluid (gas or liquid) having a small circular or rectangular cross section leaves the recipient through a nozzle entering the medium, the particles belonging to the medium will be carried out by the jet. Other particles belonging to the medium will be attracted to the jet.

If the jet flows over a large surface, the particles belonging to the medium over the jet and the particles leaving between the jet and the surface will be carried out by the jet. The density of particles over the jet remains constant because of newly arriving particles, but the particles between the surface and the jet cannot be replaced. A pressure difference appears between the upper and lower side of the jet, pushing the jet to the surface. If the surface is curved, the jet will follow its shape.

The left image in the figure below presents the normal flow of a fluid jet leaving through a nozzle of a recipient with a high, constant pressure. The final pressure of the fluid is of medium pressure.

The right image in the figure below presents the flow of a fluid over the large surface. The jet is "stuck"

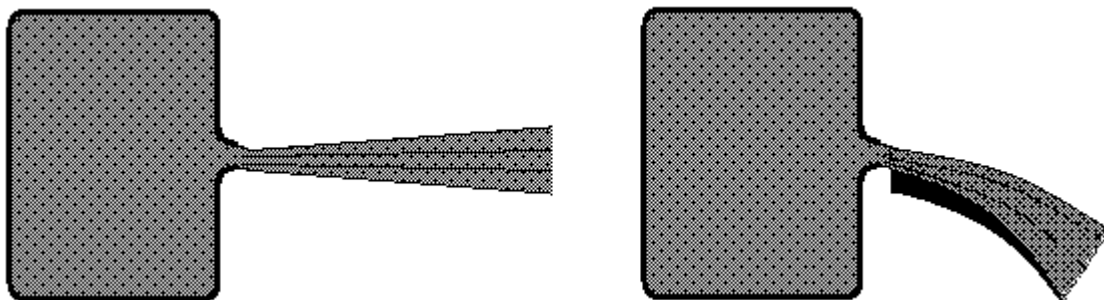

against the surface.



The process of deflection of the jet increases the speed of the jet without any variation of the pressure and temperature of the jet.

During the tests of the first jet plane in Paris, December 1936, the Romanian engineer Henry Coanda was the first to observe this phenomenon, occurring when the flames of the engine passed through a flap.

The logo of the Olympiad illustrates the Coanda flow of a fluid.

Professor Delia DAVIȚESCU, National Department of Evaluation and Examination—Ministry of Education and Research- Bucharest, Romania

Professor Adrian S.DAFINEI, PhD, Faculty of Physics – University of Bucharest, Romania

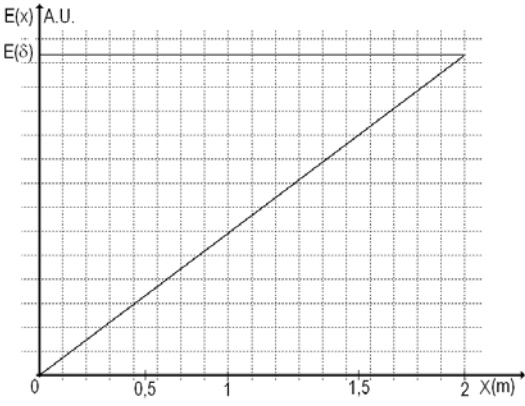
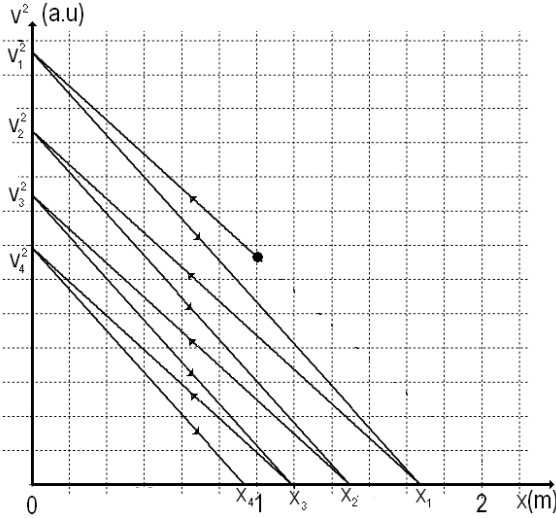

MARKING SCHEME FOR ANSWERS TO THE THEORETICAL QUESTION I

Part	MARKING SCHEME - THE THEORETICAL QUESTION I- JUMPING PARTICLE	Total Scores
I.a.	<p>For: the distance D covered by the particle to the stop</p> $\begin{cases} W(x_0) = D \cdot F_f \\ U(x_0) + E_c = D \cdot F_f \\ F_x \cdot x_0 + E_c = D \cdot F_f \end{cases}$ $D = \frac{ F_x \cdot x_0 + E_c}{F_f}$ <p>final result $D = 20\text{ m}$</p>	<p>2.00 points</p> <p>1.00 p</p> <p>0.50 p</p> <p>0.50 p</p>
I.b.	<p>For: $U(x) = F_x \cdot x$</p> 	<p>2.00 points</p> <p>1.00 p</p> <p>1.00 p</p>
I.c.	<p>For: the evolution of the square of the speed as function of the position</p> 	<p>4.00 points</p> <p>1.00 p</p>

the evolution of the speed as function of the position

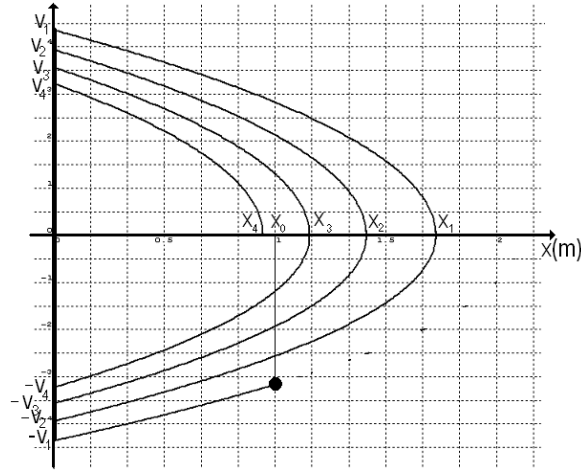

1.00 p

or
the evolution of the square of the speed as function of the position

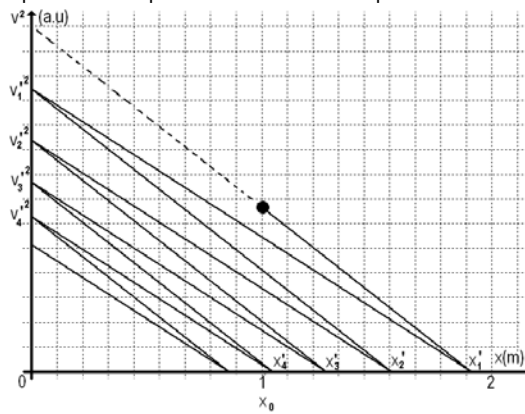

1.00 p

the evolution of the speed as function of the position

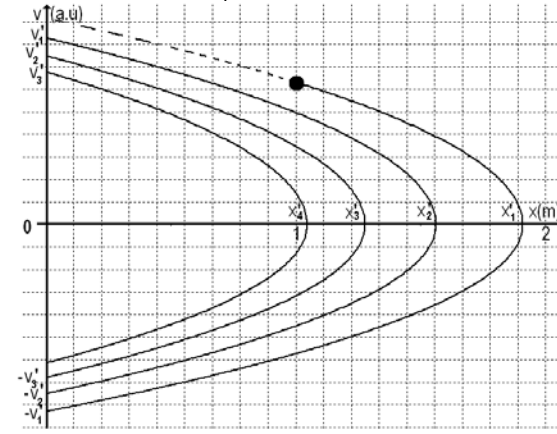

1.00 p

Total score - theoretical question I

8.00 points

Professor Delia DAVIDESCU, National Department of Evaluation and Examination—Ministry of Education and Research- Bucharest, Romania

Professor Adrian S.DAFINEI, PhD, Faculty of Physics – University of Bucharest, Romania



MARKING SCHEME FOR ANSWERS TO THE THEORETICAL QUESTION II

Part	MARKING SCHEME - THE THEORETICAL QUESTION II - DIFFERENT KIND OF OSCILLATION	Total Scores
II.a.	<p>For:</p> $\begin{cases} C = C_1 + C_2 \\ L = \frac{L_1 L_2}{L_1 + L_2} \end{cases}$ <p>the impedance Z of the circuit $Z = \bar{Z} = \frac{1}{\sqrt{\left(\frac{1}{R}\right)^2 + \left(C \cdot \omega - \frac{1}{L \cdot \omega}\right)^2}} = \frac{1}{Y}$</p> <p>$i(t) = I \cdot \sqrt{2} \cdot \sin(\omega \cdot t)$</p> <p>$u(t) = U \cdot \sqrt{2} \cdot \sin(\omega \cdot t + \varphi)$</p> <p>$P = \frac{U^2}{R} = \frac{Z^2 \cdot I^2}{R}$</p> <p>the maximal active power is realized for the maximum value of the impedance that is the minimal value of the admittance $Y_{\min} = \frac{1}{R}$.</p> <p>$P_m = R \cdot I^2$</p> <p>$f_m = \frac{1}{2\pi \cdot \sqrt{C \cdot L}}$</p> <p>$P = \frac{1}{2} P_m$</p> <p>$\frac{Z^2 \cdot I^2}{R} = \frac{1}{2} R \cdot I^2$</p> <p>$\omega^2 \pm \frac{1}{R \cdot C} \omega - \frac{1}{L \cdot C} = 0$</p> <p>the pulsation of the current ensuring an active power at half of the maximum power</p> $\begin{cases} f_+ = \frac{1}{2\pi} \left(\frac{1}{2} \sqrt{\left(\frac{1}{R \cdot C}\right)^2 + \frac{4}{L \cdot C}} + \frac{1}{2R \cdot C} \right) \\ f_- = \frac{1}{2\pi} \left(\frac{1}{2} \sqrt{\left(\frac{1}{R \cdot C}\right)^2 + \frac{4}{L \cdot C}} - \frac{1}{2R \cdot C} \right) \end{cases}$ <p>the bandwidth of the circuit $\Delta f = f_+ - f_- = \frac{1}{2\pi} \frac{1}{R \cdot C}$</p> $\begin{cases} \frac{f_m}{\Delta f} = R \sqrt{\frac{C}{L}} \\ \frac{f_m}{\Delta f} = R \sqrt{\frac{(C_1 + C_2) \cdot (L_1 + L_2)}{L_1 \cdot L_2}} \end{cases}$ <p>final result: $\frac{f_m}{\Delta f} = 150$</p>	<p>2.5 points</p> <p>0.2p</p> <p>0.2p</p> <p>0.2p</p> <p>0.2p</p> <p>0.1p</p> <p>0.2p</p> <p>0.2p</p> <p>0.1p</p> <p>0.1p</p> <p>0.2p</p> <p>0.2p</p> <p>0.1p</p> <p>0.2p</p> <p>0.1p</p> <p>0.2p</p> <p>0.1p</p>

II.b.		2.2 points
	<p>For:</p> $u(t) - L_1 \frac{di_1}{dt} = 0 \quad 0.1p$ $u(t) - L_2 \frac{di_2}{dt} = 0 \quad 0.1p$ $q_1 = C_1 \cdot u \quad 0.1p$ $\frac{dq_1}{dt} = -i_3 \quad 0.1p$ $\frac{dq_1}{dt} = C_1 \cdot \frac{du}{dt} \quad 0.1p$ $i_3 = -C_1 \cdot \frac{du}{dt} \quad 0.1p$ $i_4 = -C_2 \cdot \frac{du}{dt} \quad 0.1p$ $\left\{ \begin{aligned} \frac{di_1}{dt} &= \frac{u}{L_1} \\ \frac{di_2}{dt} &= \frac{u}{L_2} \end{aligned} \right. \quad 0.2p$ $\left\{ \begin{aligned} \frac{di_3}{dt} &= -C_1 \frac{d^2u}{dt^2} \\ \frac{di_4}{dt} &= -C_2 \frac{d^2u}{dt^2} \end{aligned} \right. \quad 0.2p$ <p>the Kirchhoff rule of the currents for the point A $i_1 + i_5 = i_3$ 0.1p</p> <p>the Kirchhoff rule of the currents for the point B $i_4 + i_5 = i_2$ 0.1p</p> $i_1 - i_3 = i_4 - i_2 \quad 0.1p$ $\frac{di_1}{dt} - \frac{di_3}{dt} = \frac{di_4}{dt} - \frac{di_2}{dt} \quad 0.1p$ $\left\{ \begin{aligned} -\frac{u}{L_1} - \frac{u}{L_2} &= C_1 \frac{d^2u}{dt^2} + C_2 \frac{d^2u}{dt^2} \\ -u \cdot \left(\frac{1}{L_1} + \frac{1}{L_2} \right) &= \frac{d^2u}{dt^2} \cdot (C_1 + C_2) \end{aligned} \right. \quad 0.2p$ $\left\{ \begin{aligned} -\frac{u}{L} &= \frac{d^2u}{dt^2} \cdot C \\ \ddot{u} + \frac{1}{LC} u &= 0 \end{aligned} \right. \quad 0.2p$ $\omega = \frac{1}{\sqrt{L \cdot C}} \quad 0.2p$	

	final result: $\omega = 10^5 \text{ rad} \cdot \text{s}^{-1}; f = \frac{10^5}{2\pi} \text{ Hz}$	0.1p	
II.c.	For: $u(t) = A \cdot \sin(\omega \cdot t + \delta)$	0.1p	3.0 points
	$i_3 = -C_1 \frac{d}{dt}(A \cdot \sin(\omega \cdot t + \delta)) = -C_1 \cdot A \cdot \omega \cdot \cos(\omega \cdot t + \delta)$	0.2p	
	$i_4 = -C_2 \frac{d}{dt}(A \cdot \sin(\omega \cdot t + \delta)) = -C_2 \cdot A \cdot \omega \cdot \cos(\omega \cdot t + \delta)$		
	$\left\{ \begin{aligned} \frac{di_1}{dt} &= \frac{u}{L_1} = \frac{1}{L_1} \cdot A \cdot \sin(\omega \cdot t + \delta) \\ \frac{di_2}{dt} &= \frac{u}{L_2} = \frac{1}{L_2} \cdot A \cdot \sin(\omega \cdot t + \delta) \end{aligned} \right.$	0.2p	
	$\left\{ \begin{aligned} i_1 &= \frac{1}{L_1 \cdot \omega} \cdot A \cdot \cos(\omega \cdot t + \delta) + M \\ i_2 &= \frac{1}{L_2 \cdot \omega} \cdot A \cdot \cos(\omega \cdot t + \delta) + N \end{aligned} \right.$	0.2p	
	Observation: in the expression above, A , M , N and δ are constants that must be determined using initially conditions ($u_0 = 40\text{V}$, $i_{01} = 0,1\text{A}$, $i_{02} = 0,2\text{A}$)		
	$\left\{ \begin{aligned} u(0) &= A \cdot \sin(\delta) = u_0 \\ \sin(\delta) &= \frac{u_0}{A} \end{aligned} \right.$	0.1p	
	$\left\{ \begin{aligned} i_{01} &= \frac{1}{L_1 \cdot \omega} \cdot A \cdot \cos(\delta) + M \\ i_{02} &= \frac{1}{L_2 \cdot \omega} \cdot A \cdot \cos(\delta) + N \end{aligned} \right.$	0.2p	
	$\left\{ \begin{aligned} i_1 - i_3 &= i_4 - i_2 \\ \frac{1}{L_1 \cdot \omega} \cdot A \cdot \cos(\omega \cdot t + \delta) + M + C_1 \cdot A \cdot \omega \cdot \cos(\omega \cdot t + \delta) &= \\ -C_2 \cdot A \cdot \omega \cdot \cos(\omega \cdot t + \delta) - \frac{1}{L_2 \cdot \omega} \cdot A \cdot \cos(\omega \cdot t + \delta) - N & \end{aligned} \right.$	0.2p	
	Observation: an identity as $A \cdot \cos \alpha + B \equiv C \cdot \cos \alpha + D$ is valuable for any value of the argument α only if $A = C$ and $B = D$		
	$\left\{ \begin{aligned} M + N &= 0 \\ A \cdot \omega \cdot (C_1 + C_2) &= -\frac{A}{\omega} \cdot \left(\frac{1}{L_1} + \frac{1}{L_2} \right) \end{aligned} \right.$	0.1p	
	$\left\{ \begin{aligned} i_{01} + i_{02} &= A \cdot \cos(\delta) \cdot \frac{1}{\omega} \cdot \left(\frac{1}{L_1} + \frac{1}{L_1} \right) \\ \cos \delta &= \frac{i_{01} + i_{02}}{A \cdot \frac{1}{\omega} \cdot \left(\frac{1}{L_1} + \frac{1}{L_1} \right)} \\ \cos \delta &= \frac{(i_{01} + i_{02}) \cdot L \cdot \omega}{A} \end{aligned} \right.$	0.2p	

	$\begin{cases} (\cos(\delta))^2 + (\sin(\delta))^2 = 1 \\ \left(\frac{u_0}{A}\right)^2 + \left(\frac{(i_{01} + i_{02}) \cdot L \cdot \omega}{A}\right)^2 = 1 \\ A = \sqrt{(u_0)^2 + ((i_{01} + i_{02}) \cdot L \cdot \omega)^2} \end{cases}$	0.1p
	the numerical value of the electrical tension on the jacks of the circuit $A = 40\sqrt{26} V$	0.1p
	$\begin{cases} \sin(\delta) = \frac{u_0}{A} \\ \sin(\delta) = \frac{1}{\sqrt{26}} \end{cases}$	0.1p
	$\begin{cases} M = i_{01} - \frac{1}{L_1 \cdot \omega} \cdot A \cdot \cos(\delta) \\ N = i_{02} - \frac{1}{L_2 \cdot \omega} \cdot A \cdot \cos(\delta) \end{cases}$	0.1p
	$\begin{cases} M = -0,1 A \\ N = 0,1 A \end{cases}$	0.1p
	$\begin{cases} i_1 = \left(\frac{4\sqrt{26}}{100} \cdot \cos(10^5 \cdot t + \arctg(1/5)) - 0,1\right) A = \tilde{i}_1 - I_0 \\ i_2 = \left(\frac{2\sqrt{26}}{100} \cdot \cos(10^5 \cdot t + \arctg(1/5)) + 0,1\right) A = \tilde{i}_2 + I_0 \end{cases}$	0.2p
	<p>Observation: the currents through the coils are the superposition of sinusoidal currents having different amplitudes and a direct current passing only through the coils.</p> <p>the direct current $I_0 = 0,1 A$</p>	0.1p
	<p>the alternative currents through the coils</p> $\begin{cases} \tilde{i}_1 = \left(\frac{4\sqrt{26}}{100} \cdot \cos(10^5 \cdot t + \arctg(1/5))\right) A \\ \tilde{i}_2 = \left(\frac{2\sqrt{26}}{100} \cdot \cos(10^5 \cdot t + \arctg(1/5))\right) A \end{cases}$	0.2p
	<p>the currents through the capacitors</p> $\begin{cases} i_3 = \left(-\frac{4\sqrt{26}}{100} \cos(10^5 \cdot t + \arctg(1/5))\right) A \\ i_4 = \left(-\frac{2\sqrt{26}}{100} \cos(10^5 \cdot t + \arctg(1/5))\right) A \end{cases}$	0.2p
	$i_5 = i_3 - i_1$	0.1p
	<p>final result: $i_5 = \left[-\frac{8\sqrt{26}}{100} \cos\left(10^5 t + \arctg \frac{1}{5}\right) + 0,1\right] A$</p>	0.2p
II.d.	<p>For:</p> <p>the amplitude of the current through the inductance L_1</p> $\max(\tilde{i}_1) = \max\left(\frac{4\sqrt{26}}{100} \cdot \cos(10^5 \cdot t + \arctg(1/5)) A\right)$	0.2p
	<p>final result: $\max(\tilde{i}_1) \approx 0,2 A$</p>	0.1p
<p>Total score theoretical question III</p>		<p>8.0 points</p>

Professor Delia DAVIDESCU, National Department of Evaluation and Examination—Ministry of Education and Research- Bucharest, Romania
 Professor Adrian S.DAFINEI, PhD, Faculty of Physics – University of Bucharest, Romania

MARKING SCHEME FOR ANSWERS TO THE THEORETICAL QUESTION III - OPTICS

Part	MARKING SCHEME - THE THEORETICAL QUESTION III - PRISMS	Total Scores
<p>III. a.</p>	<p>For:</p> $n_1(\lambda_0) = n_2(\lambda_0)$ $\lambda_0 = \sqrt{\frac{b_1 - b_2}{a_2 - a_1}}$ <p>final result: $\lambda_0 = 500\text{nm}$</p> $n_1(\lambda_0) = n_2(\lambda_0) = 1,5$	<p>1.25 points</p> <p>0.50p</p> <p>0.25p</p> <p>0.25p</p> <p>0.25p</p>
<p>III. b.</p>	<p>For the rays with different wavelength (λ_{red}, λ_0, λ_{violet}) having the same incidence angle on first prism, the paths are illustrated in the figure III.1</p> <p style="text-align: center;">Figure III.1</p>	<p>2.00 points</p>
<p>III. c.</p>	<p>For:</p> $n_1(\lambda_0) = n_2(\lambda_0) = \frac{\sin \frac{\delta_{min} + A'}{2}}{\sin \frac{A'}{2}}$ $m(\hat{A}') = 30^\circ$ $\delta_{min} = 2 \arcsin\left(\frac{3}{2} \cdot \sin \frac{A'}{2}\right) - \frac{A'}{2}$ <p>final result: $\delta_{min} \cong 30,7^\circ$</p>	<p>1.00 point</p> <p>0.25p</p> <p>0.25p</p> <p>0.25p</p> <p>0.25p</p>

<p>III. d.</p>	<p>For: the refraction law on the AD face $\sin i_1 = n_1 \cdot \sin r_1$</p> <p style="text-align: right;">0.25p</p>	<p>2.75 points</p>
<p>Figure III.2</p>		
<p>the refraction law on the AC face $n_1 \cdot \sin r_1' = n_2 \cdot \sin r_2$</p> <p style="text-align: right;">0.25p</p>		<p>0.25p</p>
<p>$r_1 + r_1' = A_1$</p> <p style="text-align: right;">0.25p</p>		<p>0.25p</p>
<p>$r_2 = A_2$</p> <p style="text-align: right;">0.25p</p>		<p>0.25p</p>
<p>$i_1 = 30^\circ$</p> <p style="text-align: right;">0.25p</p>		<p>0.25p</p>
$\sqrt{4n_1^2 - 1} = \frac{2n_2 \cdot \sin A_2 + \cos A_1}{\sin A_1}$ <p style="text-align: right;">0.50p</p>		<p>0.50p</p>
$3 \cdot n_1^2 = 1 + n_2 + n_2^2$ <p style="text-align: right;">0.25p</p>		<p>0.25p</p>
$\lambda^4 \cdot (3a_1^2 - a_2^2 - a_2 - 1) + (6a_1b_1 - b_2 - 2a_2b_2) \cdot \lambda^2 + 3b_1^2 - b_2^2 = 0$ <p style="text-align: right;">0.50p</p>		<p>0.50p</p>
<p>final result: $\lambda \cong 1,2 \mu m$</p> <p style="text-align: right;">0.25p</p>		<p>0.25p</p>
<p>Total score theoretical question III</p>		<p>7.00 points</p>

Professor Delia DAVIDESCU, National Department of Evaluation and Examination—Ministry of Education and Research- Bucharest, Romania
 Professor Adrian S. DAFINEI, PhD, Faculty of Physics – University of Bucharest, Romania

MARKING SCHEME FOR ANSWERS TO THE THEORETICAL QUESTION IV

Part	MARKING SCHEME - THE THEORETICAL QUESTION IV- COMPTON SCATTERING	Total Scores
IV.	<p>For: the situation before the first scattering of photon</p> <p>the momentum \vec{p}_i and the energy E_i of the initial photon $\begin{cases} \vec{p}_i = \frac{h}{\lambda_i} = \frac{h \cdot f_i}{c} \\ E_i = h \cdot f_i \end{cases}$ 0.3p</p> <p>the frequency of initial photon $f_i = \frac{c}{\lambda_i}$ 0.1p</p> <p>the momentum \vec{p}_{oe} and the energy E_{oe} of initial, free electron in motion $\begin{cases} \vec{p}_{oe} = m \cdot \vec{v}_{1e} = \frac{m_0 \cdot \vec{v}_{1e}}{\sqrt{1-\beta^2}} \\ E_{oe} = m \cdot c^2 = \frac{m_0 \cdot c^2}{\sqrt{1-\beta^2}} \end{cases}$ 0.3p</p> <p>De Broglie wavelength of the first electron $\lambda_{oe} = \frac{h}{p_{oe}} = \frac{h}{m_0 \cdot v_{1e}} \sqrt{1-\beta^2}$ 0.2p</p> <p>the situation after the scattering of photon</p> <p>the momentum \vec{p}_o and the energy E_o of the scattered photon $\begin{cases} \vec{p}_o = \frac{h}{\lambda_o} = \frac{h \cdot f_o}{c} \\ E_o = h \cdot f_o \end{cases}$ 0.3p</p> <p>the frequency of scattered photon $f_o = \frac{c}{\lambda_o}$ 0.1p</p>	7.0 points

the principles of conservation of moments and energy $\begin{cases} \vec{P}_i + \vec{p}_{oe} = \vec{p}_0 \\ E_i + E_{oe} = E_0 + E_{1e} \end{cases}$ 0.3p

the conservation of moment on Ox direction $\frac{h \cdot f_i}{c} + m \cdot v_{1e} \cdot \cos \alpha = \frac{h \cdot f_0}{c} \cos \theta$ 0.3p

the conservation of moment on Oy $m \cdot v_{1e} \cdot \sin \alpha = \frac{h \cdot f_0}{c} \sin \theta$ 0.3p

$$\frac{m_0^2 \cdot c^2}{1 - \left(\frac{v_{1e}}{c}\right)^2} \cdot v_{1e}^2 = h^2 \cdot (f_0^2 + f_1^2 - 2f_0 \cdot f_1 \cdot \cos \theta)$$
 0.4p

The conservation of energy $m \cdot c^2 + h \cdot f_1 = m_0 \cdot c^2 + h \cdot f_0$ 0.3p

or $\frac{m_0 \cdot c^2}{\sqrt{1 - \left(\frac{v_{1e}}{c}\right)^2}} = m_0 \cdot c^2 + h \cdot (f_0 - f_1)$ 0.2p

$$\frac{m_0^2 \cdot c^4}{1 - \left(\frac{v_{1e}}{c}\right)^2} = m_0^2 \cdot c^4 + h^2 \cdot (f_0 - f_1)^2 + m_0 \cdot h \cdot c^2 \cdot (f_0 - f_1)$$
 0.2p

$$\frac{h}{m_0 \cdot c} (1 - \cos \theta) = \frac{c}{f_1} - \frac{c}{f_0}$$
 0.2p

$$\Lambda = \frac{h}{m_0 \cdot c}$$
 0.2p

the wavelength of scattered photon $\lambda_0 = \lambda_i - \Lambda \cdot (1 - \cos \theta)$ 0.3p

$$\begin{cases} \lambda_i < \lambda_0 \\ E_i > E_0 \end{cases}$$
 0.1p

the situation before the second collision

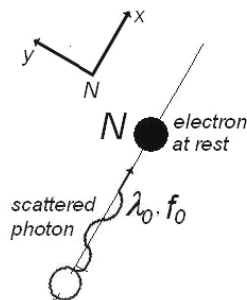

the situation after this scattering process

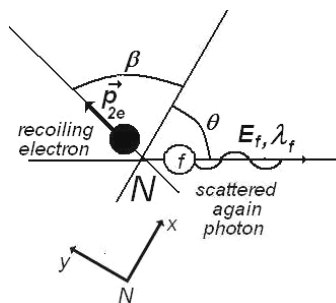

	<p>The conservation principle for moment in the scattering process</p> $\begin{cases} \frac{h}{\lambda_0} = \frac{h}{\lambda_f} \cos \theta + m \cdot v_{2e} \cdot \cos \beta \\ \frac{h}{\lambda_f} \sin \theta - m \cdot v_{2e} \cdot \sin \beta = 0 \end{cases}$	0.3p
	$\left(\frac{h}{\lambda_f}\right)^2 + \left(\frac{h}{\lambda_0}\right)^2 - \frac{2 \cdot h^2}{\lambda_0 \cdot \lambda_f} \cos \theta = (m \cdot v_{2e})^2$	0.3p
	$\begin{cases} \frac{h}{m_0 \cdot c} \cdot (1 - \cos \theta) = \lambda_f - \lambda_0 \\ \lambda_f - \lambda_0 = \Lambda \cdot (1 - \cos \theta) \end{cases}$	0.5p
	$\begin{cases} \lambda_f > \lambda_0 \\ E_f < E_0 \end{cases}$	0.1p
	$\begin{cases} \lambda_f = 1,25 \times 10^{-10} \text{ m} \\ \Lambda = \frac{6,6 \times 10^{-34}}{9,1 \times 10^{-31} \cdot 3 \times 10^8} \text{ m} = 2,41 \times 10^{-12} \text{ m} = 0,02 \times 10^{-10} \text{ m} \end{cases}$	0.2p
	the value of wavelength of photon before the second scattering $\lambda_0 = 1,23 \times 10^{-10} \text{ m}$	0.1p
	$\lambda_i = \lambda_f$	0.3p
	$\begin{cases} \vec{p}_{1e} = \vec{p}_{2e} \\ E_{1e} = E_{2e} \end{cases}$	0.2p
	the moment of final electron	
	$p_{2e} = h \sqrt{\frac{1}{\lambda_f^2} + \frac{1}{(\lambda_f - \Lambda(1 - \cos \theta))^2} - \frac{2 \cdot \cos \theta}{\lambda_f \cdot (\lambda_f - \Lambda(1 - \cos \theta))}}$	0.4p
	The de Broglie wavelength of second electron after scattering (and of first electron before scattering)	
	$\lambda_{1e} = \lambda_{2e} = 1 / \left(\sqrt{\frac{1}{\lambda_f^2} + \frac{1}{(\lambda_f - \Lambda(1 - \cos \theta))^2} - \frac{2 \cdot \cos \theta}{\lambda_f \cdot (\lambda_f - \Lambda(1 - \cos \theta))}} \right)$	0.3p
	final result: $\lambda_{1e} = \lambda_{2e} = 1,24 \times 10^{-10} \text{ m}$	0.2p
Total score theoretical question IV		7.0 points

Professor Delia DAVIDESCU, National Department of Evaluation and Examination—Ministry of Education and Research- Bucharest, Romania
 Professor Adrian S.DAFINEI, PhD, Faculty of Physics – University of Bucharest, Romania

Problems of the XV International Physics Olympiad (Sigtuna, 1984)

Lars Gislén
Department of Theoretical Physics, University of Lund, Sweden

Theoretical problems

Problem 1

a) Consider a plane-parallel transparent plate, where the refractive index, n , varies with distance, z , from the lower surface (see figure). Show that $n_A \sin \alpha = n_B \sin \beta$. The notation is that of the figure.

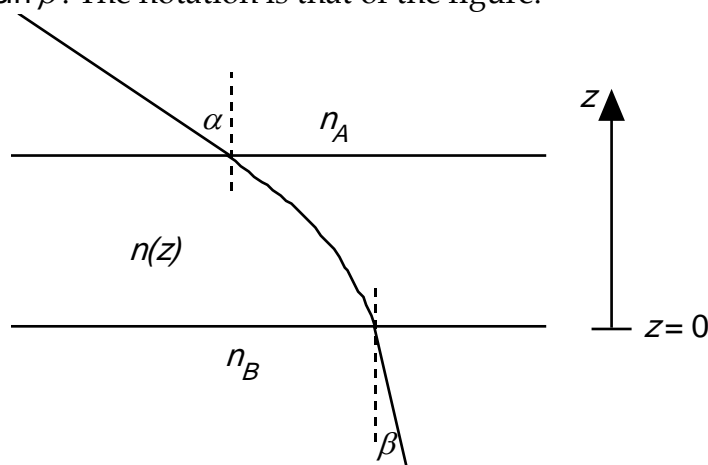

b) Assume that you are standing in a large flat desert. At some distance you see what appears to be a water surface. When you approach the "water" it seems to move away such that the distance to the "water" is always constant. Explain the phenomenon.

c) Compute the temperature of the air close to the ground in b) assuming that your eyes are located 1.60 m above the ground and that the distance to the "water" is 250 m. The refractive index of the air at 15 °C and at normal air pressure (101.3 kPa) is 1.000276. The temperature of the air more than 1 m above the ground is assumed to be constant and equal to 30 °C. The atmospheric pressure is assumed to be normal. The refractive index, n , is such that $n - 1$ is proportional to the density of the air. Discuss the accuracy of your result.

Solution:

a) From the figure we get

$$n_A \sin \alpha = n_1 \sin \alpha_1 = n_2 \sin \alpha_2 = \dots = n_B \sin \beta$$

b) The phenomenon is due to total reflexion in a warm layer of air when $\beta = 90^\circ$. This gives

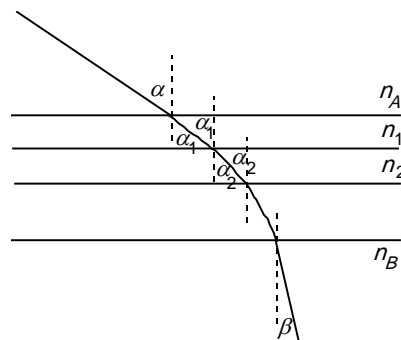

$$n_A \sin \alpha = n_B$$

c) As the density, ρ , of the air is inversely proportional to the absolute temperature, T , for fixed pressure we have

$$n(T) = 1 + k \cdot \rho = 1 + k/T$$

The value given at 15 °C determines the value of $k = 0.0795$.

In order to have total reflexion we have $n_{30} \sin \alpha = n_T$ or

$$\left(1 + \frac{k}{303}\right) \cdot \frac{L}{\sqrt{h^2 + L^2}} = \left(1 + \frac{k}{T}\right) \text{ with } h = 1.6 \text{ m and } L = 250 \text{ m}$$

As $h \ll L$ we can use a power expansion in h/L :

$$T = \frac{303}{\left(\frac{303}{k} + 1\right) \frac{1}{\sqrt{1 + h^2/L^2}} - \frac{303}{k}} \approx 303 \left(1 + \frac{303h^2}{2kL^2}\right) = 328\text{K} = 56^\circ\text{C}$$

Problem 2

In certain lakes there is a strange phenomenon called “seiching” which is an oscillation of the water. Lakes in which you can see this phenomenon are normally long compared with the depth and also narrow. It is natural to see waves in a lake but not something like the seiching, where the entire water volume oscillates, like the coffee in a cup that you carry to a waiting guest.

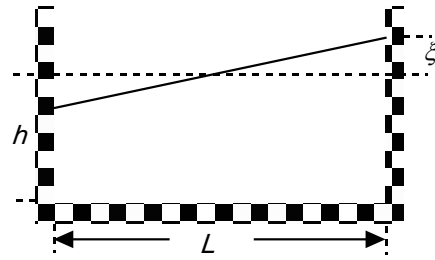

In order to create a model of the seiching we look at water in a rectangular container. The length of the container is L and the depth of the water is h . Assume that the surface of the water to begin with makes a small angle with the horizontal. The seiching will then start, and we assume that the water surface continues to be plane but oscillates around an axis in the horizontal plane and located in the middle of the container.

Create a model of the movement of the water and derive a formula for the oscillation period T . The starting conditions are given in figure above. Assume that $\xi \ll h$. The table below shows experimental oscillation periods for different water depths in two containers of different lengths. Check in some reasonable way how well the formula that you have derived agrees with the experimental data. Give your opinion on the quality of your model.

Table 1. $L = 479$ mm

h mm	30	50	69	88	107	124	142
T s	1.78	1.40	1.18	1.08	1.00	0.91	0.82

Table 2. $L = 143$ mm

h mm	31	38	58	67	124
T s	0.52	0.52	0.43	0.35	0.28

The graph below shows results from measurements in lake Vättern in Sweden. This lake has a length of 123 km and a mean depth of 50 m. What is the time scale in the graph?

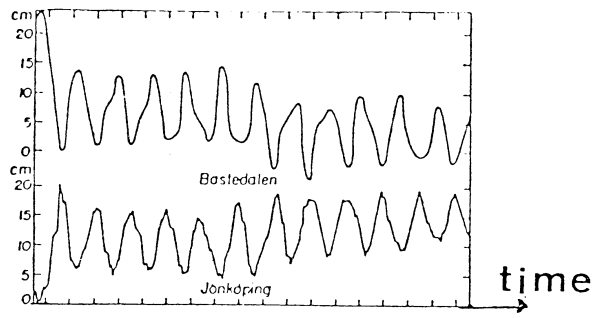

The water surface level in Bastudalen (northern end of lake Vättern) and Jönköping (southern end).

Solution:

In the coordinate system of the figure, we have for the centre of mass coordinates of the two triangular parts of the water

$$(x_1, y_1) = (L/3, h/2 + \xi/3) \quad (x_2, y_2) = (-L/3, h/2 - \xi/3).$$

For the entire water mass the centre of mass coordinates will then be

$$(x_{CoM}, y_{CoM}) = \left(\frac{\xi L}{6h}, \frac{\xi^2}{6h} \right)$$

Due to that the y component is quadratic in ξ will be much much smaller than the x component.

The velocities of the water mass are

$$(v_x, v_y) = \left(\frac{\partial x}{\partial \xi}, \frac{\partial y}{\partial \xi} \right),$$

and again the vertical component is much smaller than the horizontal one.

We now in our model neglect the vertical components. The total energy (kinetic + potential) will then be

$$W = W_k + W_p = \frac{1}{2} M \frac{\xi^2 L^2}{36h^2} + Mg \frac{\xi^2}{6h}$$

For a harmonic oscillator we have

$$W = W_k + W_p = \frac{1}{2} m \dot{x}^2 + \frac{1}{2} m \omega^2 x^2$$

Identifying gives

$$\omega = \sqrt{\frac{12gh}{L}} \quad \text{or} \quad T_{model} = \frac{\pi L}{\sqrt{3h}}.$$

Comparing with the experimental data we find $T_{experiment} \approx 1.1 \cdot T_{model}$, our model gives a slight underestimation of the oscillation period.

Applying our corrected model on the Vättern data we have that the oscillation period of the seiching is about 3 hours.

Many other models are possible and give equivalent results.

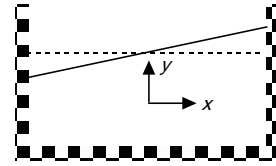

Problem 3

An electronic frequency filter consists of four components coupled as in the upper figure. The impedance of the source can be neglected and the impedance of the load can be taken as infinite. The filter should be such that the voltage ratio U_{out}/U_{in} has a frequency dependence shown in the lower where U_{in} is the input voltage and U_{out} is the output voltage. At frequency f_0 the phase lag between the two voltages is zero.

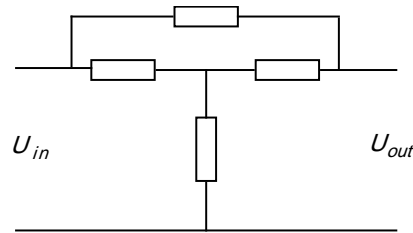

In order to build the filter you can choose from the following components:

- 2 resistors, 10 k Ω
- 2 capacitors, 10 nF
- 2 solenoids, 160 mH (iron-free and with negligible resistance)

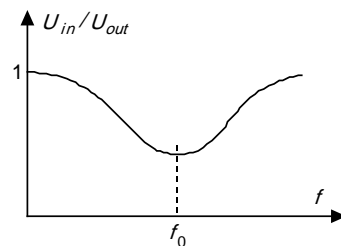

Construct, by combining four of these components, a filter that fulfils the stated conditions. Determine the frequency f_0 and the ratio U_{out}/U_{in} at this frequency for as many component combinations as possible.

Solution:

The conditions at very high and very low frequencies can be satisfied with for example the following circuit

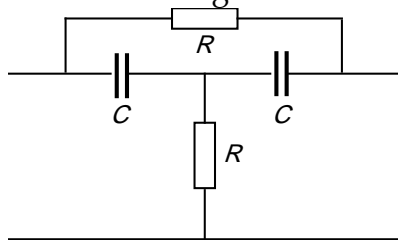

Using either the graphic vector method or the analytic $j\omega$ method we can show that the minimum occurs for a frequency $f_0 = \frac{1}{2\pi RC}$ when the ratio between the output and input voltages is $2/3$. Switching the resistors and the capacitors gives a new circuit with the same frequency f_0 . Another two possibilities is to exchange the capacitors for solenoids where we get $f_0 = \frac{R}{2\pi L}$. There are further eight solutions with unsymmetric patterns of the electronic components.

Experimental problems

Problem 1

You have at your disposal the following material:

- (1) A sine wave voltage generator set to a frequency of 0,20 kHz.
- (2) A dual ray oscilloscope.
- (3) Millimeter graph paper.
- (4) A diod.
- (5) A capacitor of $0.10 \mu\text{F}$ (square and black).
- (6) An unknown resistor R (red).
- (7) A coupling plate.
- (8) Coupling wires.

Build the circuit shown in the figure.

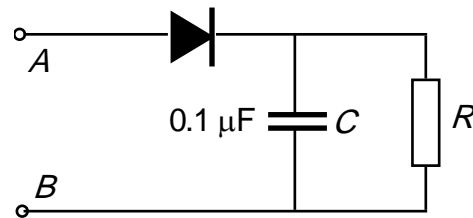

Connect the terminals A and B to the sine wave generator set to a frequency of 0.20 kHz. Determine experimentally the mean power developed in the resistor R when the amplitude of the generator voltage is 2.0 V (that is the peak-to-peak voltage is 4.0 V).

Solution:

The picture to the right shows the oscilloscope voltage over the resistor. The period of the sine wave is 5 ms and this gives the relation 1 horizontal division = 1.5 ms. The actual vertical scale was 0.85 V / division. The first rising part of the curve is a section of a

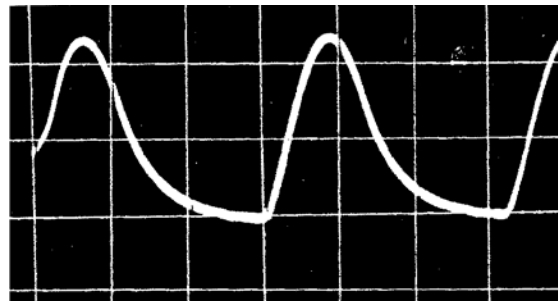

sine wave, the second falling part is an exponential decay determined by the time constant of the resistor and capacitor. Reading from the display the "half-life" $t_{1/2} = RC \cdot \ln 2$ turns out to be 0.5 ms. This gives $R = 7.2 \text{ k}\Omega$. The mean power developed in the resistor is

$$\langle P \rangle = \frac{1}{T} \int_0^T \frac{U^2(t)}{R} dt. \text{ Numerical integration (counting squares) gives}$$

$$\int_0^T U^2(t) dt = 4,5 \cdot 10^{-3} \text{ V}^2\text{s from which } \langle P \rangle \approx 0.1 \text{ mW.}$$

Problem 2

Material:

- (1) A glow discharge lamp connected to 220 V, alternating current.
- (2) A laser producing light of unknown wavelength.
- (3) A grating.
- (4) A transparent "micro-ruler", 1 mm long with 100 subdivisions, the ruler is situated exactly in the centre of the circle.
- (5) A 1 m long ruler
- (6) Writing material.

The spectrum of the glow discharge lamp has a number of spectral lines in the region yellow-orange-red. One of the yellow lines in the short wavelength part of this spectrum is very strong. Determine the wavelength of this spectral line. Estimate the accuracy of your measurement.

Note: If you happen to know the wavelength of the laser light beforehand you are not allowed to use that value in your computation.

Warning. Do not look into the laser beam. Do not touch the surface of the grating or the surface of the transparent micro-ruler.

Solution:

Using the micro-ruler with we can determine the wavelength of the laser light. Knowing this wavelength we can calibrate the grating and then use it to determine the unknown wavelength from the glow discharge lamp. We cannot use the micro-ruler to determine this wavelength because the intensity of the light from the lamp is too weak.

Problems and solutions of the 16th IPhO* Portorož, Slovenia, (Former Yugoslavia), 1985

Contents

1 Problems	2
1.1 Theoretical competition	2
1.2 Experimental competition	5
2 Solutions	9
2.1 Theoretical competition	9
2.2 Experimental competition	16

1 Problems

1.1 Theoretical competition

Problem 1

A young radio amateur maintains a radio link with two girls living in two towns. He positions an aerial array such that when the girl living in town A receives a maximum signal, the girl living in town B receives no signal and vice versa. The array is built from two vertical rod aerials transmitting with equal intensities uniformly in all directions in the horizontal plane.

*Edited by B. Golli, Faculty of Education, University of Ljubljana, and J. Stefan Institute, Ljubljana, Slovenia, e-mail:bojan.golli@ijs.si

- a) Find the parameters of the array, i. e. the distance between the rods, its orientation and the phase shift between the electrical signals supplied to the rods, such that the distance between the rods is minimum.
- b) Find the numerical solution if the boy has a radio station transmitting at 27 MHz and builds up the aerial array at Portorož. Using the map he has found that the angles between the north and the direction of A (Koper) and of B (small town of Buje in Istria) are 72° and 157° , respectively.

Problem 2

In a long bar having the shape of a rectangular parallelepiped with sides a , b , and c ($a \gg b \gg c$), made from the semiconductor InSb flows a current I parallel to the edge a . The bar is in an external magnetic field B which is parallel to the edge c . The magnetic field produced by the current I can be neglected. The current carriers are electrons. The average velocity of electrons in a semiconductor in the presence of an electric field only is $v = \mu E$, where μ is called mobility. If the magnetic field is also present, the electric field is no longer parallel to the current. This phenomenon is known as the Hall effect.

- a) Determine what the magnitude and the direction of the electric field in the bar is, to yield the current described above.
- b) Calculate the difference of the electric potential between the opposite points on the surfaces of the bar in the direction of the edge b .
- c) Find the analytic expression for the DC component of the electric potential difference in case b) if the current and the magnetic field are alternating (AC); $I = I_0 \sin \omega t$ and $B = B_0 \sin(\omega t + \delta)$.
- d) Design and explain an electric circuit which would make possible, by exploiting the result c), to measure the power consumption of an electric apparatus connected with the AC network.

Data: The electron mobility in InSb is $7.8 \text{ m}^2\text{T/Vs}$, the electron concentration in InSb is $2.5 \cdot 10^{22} \text{ m}^{-3}$, $I = 1.0 \text{ A}$, $B = 0.10 \text{ T}$, $b = 1.0 \text{ cm}$, $c = 1.0 \text{ mm}$, $e_0 = -1.6 \cdot 10^{-19} \text{ As}$.

Problem 3

In a space research project two schemes of launching a space probe out of the Solar system are discussed. The first scheme (i) is to launch the probe with a velocity large enough to escape from the Solar system directly. According to the second one (ii), the probe is to approach one of the outer planets, and with its help change its direction of motion and reach the velocity necessary to escape from the Solar system. Assume that the probe moves under the gravitational field of only the Sun or the planet, depending on whichever field is stronger at that point.

- a) Determine the minimum velocity and its direction relative to the Earth's motion that should be given to the probe on launching according to scheme (i).
- b) Suppose that the probe has been launched in the direction determined in a) but with another velocity. Determine the velocity of the probe when it crosses the orbit of Mars, i. e., its parallel and perpendicular components with respect to this orbit. Mars is not near the point of crossing, when crossing occurs.
- c) Let the probe enter the gravitational field of Mars. Find the minimum launching velocity from the Earth necessary for the probe to escape from the Solar system.

Hint: From the result a) you know the optimal magnitude and the direction of the velocity of the probe that is necessary to escape from the Solar system after leaving the gravitational field of Mars. (You do not have to worry about the precise position of Mars during the encounter.) Find the relation between this velocity and the velocity components before the probe enters the gravitational field of Mars; i. e., the components you determined in b). What about the conservation of energy of the probe?

- d) Estimate the maximum possible fractional saving of energy in scheme (ii) with respect to scheme (i). Notes: Assume that all the planets revolve round the Sun in circles, in the same direction and in the same plane. Neglect the air resistance, the rotation of the Earth around its axis as well as the energy used in escaping from the Earth's gravitational field.

Data: Velocity of the Earth round the Sun is 30 km/s, and the ratio of the distances of the Earth and Mars from the Sun is $2/3$.

1.2 Experimental competition

Exercise A

Follow the acceleration and the deceleration of a brass disk, driven by an AC electric motor. From the measured times of half turns, plot the angle, angular velocity and angular acceleration of the disk as functions of time. Determine the torque and power of the motor as functions of angular velocity.

Instrumentation

1. AC motor with switch and brass disk
2. Induction sensor
3. Multichannel stop-watch (computer)

Instruction

The induction sensor senses the iron pegs, mounted on the disk, when they are closer than 0.5 mm and sends a signal to the stop-watch. The stop-watch is programmed on a computer so that it registers the time at which the sensor senses the approaching peg and stores it in memory. You run the stop-watch by giving it simple numerical commands, i. e. pressing one of the following numbers:

5 - MEASURE.

The measurement does not start immediately. The stop-watch waits until you specify the number of measurements, that is, the number of successive detections of the pegs:

3 - 30 measurements

6 - 60 measurements

Either of these commands starts the measurement. When a measurement is completed, the computer displays the results in graphic form. The vertical axis represents the length of the interval between detection of the pegs and the horizontal axis is the number of the interval.

7 - display results in numeric form.

The first column is the number of times a peg has passed the detector, the second is the time elapsed from the beginning of the measurement and the third column is the length of the time interval between the detection of the two pegs.

In the case of 60 measurements:

8 - displays the first page of the table

2 - displays the second page of the table

4 - displays the results graphically.

A measurement can be interrupted before the prescribed number of measurements by pressing any key and giving the disk another half turn.

The motor runs on 25 V AC. You start it with a switch on the mounting base. It may sometimes be necessary to give the disk a light push or to tap the base plate to start the disk.

The total moment of inertia of all the rotating parts is: $(14.0 \pm 0.5) \cdot 10^{-6} \text{ kgm}^2$.

Exercise B

Locate the position of the centers and determine the orientations of a number of identical permanent magnets hidden in the black painted block. A diagram of one such magnet is given in Figure 1. The coordinates x , y and z should be measured from the red corner point, as indicated in Figure 2.

Determine the z component of the magnetic induction vector \vec{B} in the (x, y) plane at $z = 0$ by calibrating the measuring system beforehand.

Find the greatest magnetic induction B obtainable from the magnet supplied.

Instrumentation

1. Permanent magnet given is identical to the hidden magnets in the block.
2. Induction coil; 1400 turns, $R = 230 \Omega$

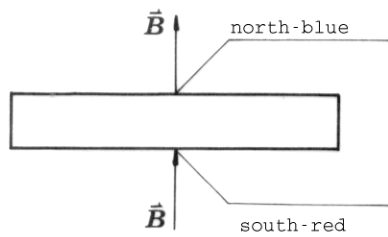

Fig. 1

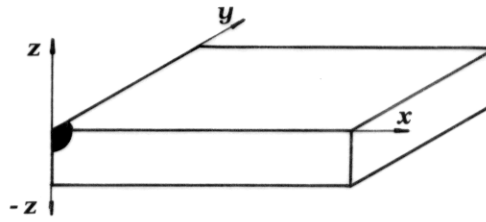

Fig. 2

3. Field generating coils, 8800 turns, $R = 990 \Omega$, 2 pieces
4. Black painted block with hidden magnets
5. Voltmeter (ranges 1 V, 3 V and 10 V recommended)
6. Electronic circuit (recommended supply voltage 24 V)
7. Ammeter
8. Variable resistor 3.3 k Ω
9. Variable stabilized power supply 0 - 25 V, with current limiter
10. Four connecting wires
11. Supporting plate with fixing holes
12. Rubber bands, multipurpose (e. g. for coil fixing)
13. Tooth picks
14. Ruler
15. Thread

Instructions

For the magnet-search only nondestructive methods are acceptable. The final report should include results, formulae, graphs and diagrams. The diagrams should be used instead of comments on the methods used wherever possible.

The proper use of the induced voltage measuring system is shown in Figure 3.

This device is capable of responding to the magnetic field. The peak voltage is proportional to the change of the magnetic flux through the coil.

The variable stabilized power supply is switched ON (1) or OFF (0) by the lower left pushbutton. By the (U) knob the output voltage is increased through the clockwise rotation. The recommended voltage is 24 V. Therefore switch the corresponding toggle switch to the 12 V - 25 V position. With this instrument either the output voltage U or the output current I is measured, with respect to the position of the corresponding toggle switch (V,A). However, to get the output voltage the upper right switch should be in the 'Vklop' position. By the knob (I) the output current is limited below the preset value. When rotated clockwise the power supply can provide 1.5 A at most.

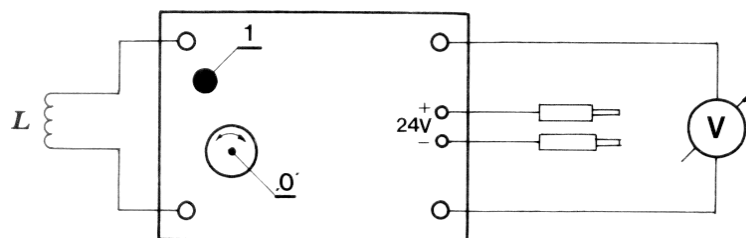

Fig. 3 '0' zero adjust dial, '1' push reset button

Note: permeability of empty space $\mu_0 = 1.2 \cdot 10^{-6}$ Vs/Am.

2 Solutions

2.1 Theoretical competition

Problem 1

a) Let the electrical signals supplied to rods 1 and 2 be $E_1 = E_0 \cos \omega t$ and $E_2 = E_0 \cos(\omega t + \delta)$, respectively. The condition for a maximum signal in direction ϑ_A (Fig. 4) is:

$$\frac{2\pi a}{\lambda} \sin \vartheta_A - \delta = 2\pi N$$

and the condition for a minimum signal in direction ϑ_B :

$$\frac{2\pi a}{\lambda} \sin \vartheta_B - \delta = 2\pi N' + \pi \quad (2p.)$$

where N and N' are arbitrary integers. In addition, $\vartheta_A - \vartheta_B = \varphi$, where

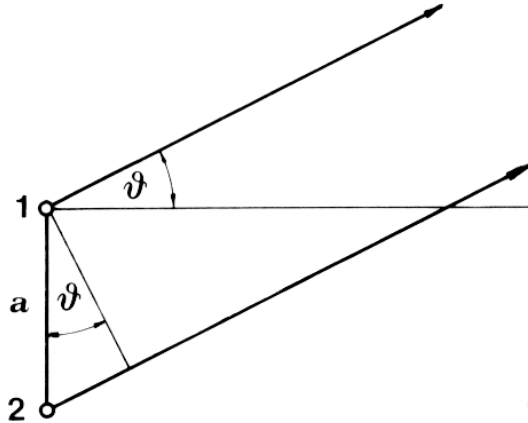

Fig. 4

φ is given. The problem can now be formulated as follows: Find the parameters a , ϑ_A , ϑ_B , δ , N , and N' satisfying the above equations such, that a is minimum.

We first eliminate δ by subtracting the second equation from the first one:

$$a \sin \vartheta_A - a \sin \vartheta_B = \lambda(N - N' - \frac{1}{2}).$$

Using the sine addition theorem and the relation $\vartheta_B = \vartheta_A - \varphi$:

$$2a \cos(\vartheta_A - \frac{1}{2}\varphi) \sin \frac{1}{2}\varphi = \lambda(N - N' - \frac{1}{2})$$

or

$$a = \frac{\lambda(N - N' - \frac{1}{2})}{2 \cos(\vartheta_A - \frac{1}{2}\varphi) \sin \frac{1}{2}\varphi}.$$

The minimum of a is obtained for the greatest possible value of the denominator, i. e.:

$$\cos(\vartheta_A - \frac{1}{2}\varphi) = 1, \quad \vartheta_A = \frac{1}{2}\varphi,$$

and the minimum value of the numerator, i. e.:

$$N - N' = 1.$$

The solution is therefore:

$$a = \frac{\lambda}{4 \sin \frac{1}{2}\varphi}, \quad \vartheta_A = \frac{1}{2}\varphi, \quad \vartheta_B = -\frac{1}{2}\varphi \quad \text{and} \quad \delta = \frac{1}{2}\pi - 2\pi N. \quad (6p.)$$

($N = 0$ can be assumed throughout without losing any physically relevant solution.)

b) The wavelength $\lambda = c/\nu = 11.1$ m, and the angle between directions A and B, $\varphi = 157^\circ - 72^\circ = 85^\circ$. The minimum distance between the rods is $a = 4.1$ m, while the direction of the symmetry line of the rods is $72^\circ + 42.5^\circ = 114.5^\circ$ measured from the north. (2 p.)

Problem 2

a) First the electron velocity is calculated from the current I:

$$I = jS = ne_0vbc, \quad v = \frac{I}{ne_0bc} = 25 \text{ m/s}.$$

The components of the electric field are obtained from the electron velocity. The component in the direction of the current is

$$E_{\parallel} = \frac{v}{\mu} = 3.2 \text{ V/m}. \quad (0.5\text{p.})$$

The component of the electric field in the direction b is equal to the Lorentz force on the electron divided by its charge:

$$E_{\perp} = vB = 2.5 \text{ V/m}. \quad (1\text{p.})$$

The magnitude of the electric field is

$$E = \sqrt{E_{\parallel}^2 + E_{\perp}^2} = 4.06 \text{ V/m}. \quad (0.5\text{p.})$$

while its direction is shown in Fig. 5 (Note that the electron velocity is in the opposite direction with respect to the current.) (1.5 p.)

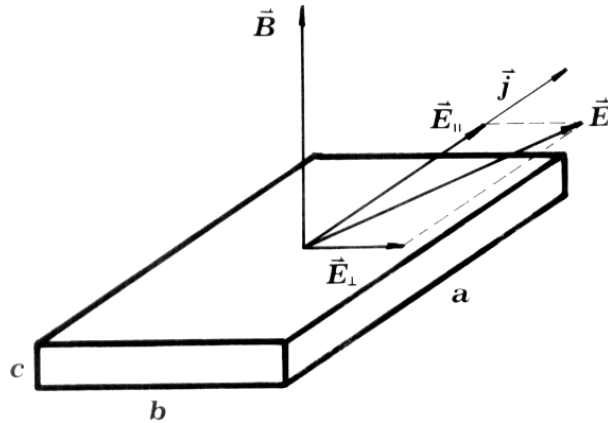

Fig. 5

b) The potential difference is

$$U_H = E_{\perp}b = 25 \text{ mV} \quad (1\text{p.})$$

c) The potential difference U_H is now time dependent:

$$U_H = \frac{IBb}{ne_0bc} = \frac{I_0B_0}{ne_0c} \sin \omega t \sin(\omega t + \delta).$$

The DC component of U_H is

$$\bar{U}_H = \frac{I_0B_0}{2ne_0c} \cos \delta. \quad (3p.)$$

d) A possible experimental setup is shown in Fig. 6

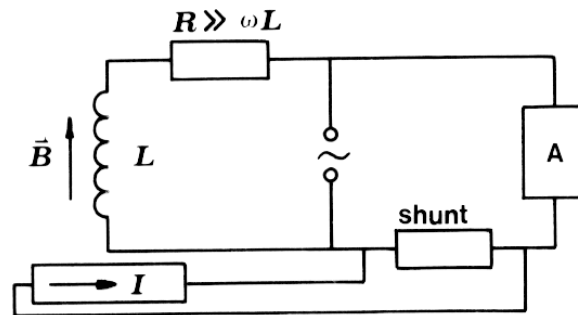

Fig. 6

(2 p.)

Problem 3

a) The necessary condition for the space-probe to escape from the Solar system is that the sum of its kinetic and potential energy in the Sun's gravitational field is larger than or equal to zero:

$$\frac{1}{2}mv_a^2 - \frac{GmM}{R_E} \geq 0,$$

where m is the mass of the probe, v_a its velocity relative to the Sun, M the mass of the Sun, R_E the distance of the Earth from the Sun and G the gravitational constant. Using the expression for the velocity of the Earth, $v_E = \sqrt{GM/R_E}$, we can eliminate G and M from the above condition:

$$v_a^2 \geq \frac{2GM}{R_E} = 2v_E^2. \quad (1p.)$$

Let v'_a be the velocity of launching relative to the Earth and ϑ the angle between \vec{v}_E and \vec{v}'_a (Fig. 7). Then from $\vec{v}_a = \vec{v}'_a + \vec{v}_E$ and $v_a^2 = 2v_E^2$ it

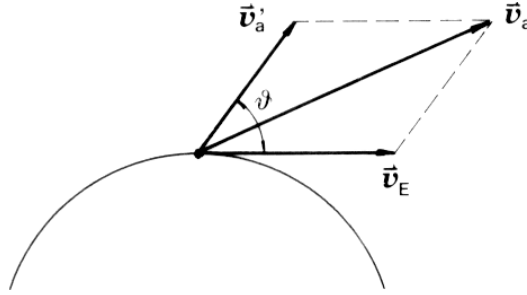

Fig. 7

follows:

$$v_a'^2 + 2v'_a v_E \cos \vartheta - v_E^2 = 0$$

and

$$v'_a = v_E \left[-\cos \vartheta + \sqrt{1 + \cos^2 \vartheta} \right].$$

The minimum velocity is obtained for $\vartheta = 0$:

$$v'_a = v_E(\sqrt{2} - 1) = 12.3 \text{ km/s}. \quad (1p.)$$

b) Let v'_b and v_b be the velocities of launching the probe in the Earth's and Sun's system of reference respectively. For the solution (a), $v_b = v'_b + v_E$. From the conservation of angular momentum of the probe:

$$mv_b R_E = mv_{\parallel} R_M \quad (1p.)$$

and the conservation of energy:

$$\frac{1}{2}mv_b^2 - \frac{GmM}{R_E} = \frac{1}{2}m(v_{\parallel}^2 + v_{\perp}^2) - \frac{GmM}{R_M} \quad (1p.)$$

we get for the, parallel component of the velocity (Fig. 8):

$$v_{\parallel} = (v'_b + v_E)k,$$

and for the perpendicular component:

$$v_{\perp} = \sqrt{(v'_b + v_E)^2(1 - k^2) - 2v_E^2(1 - k)}. \quad (1p.)$$

where $k = R_E/R_M$.

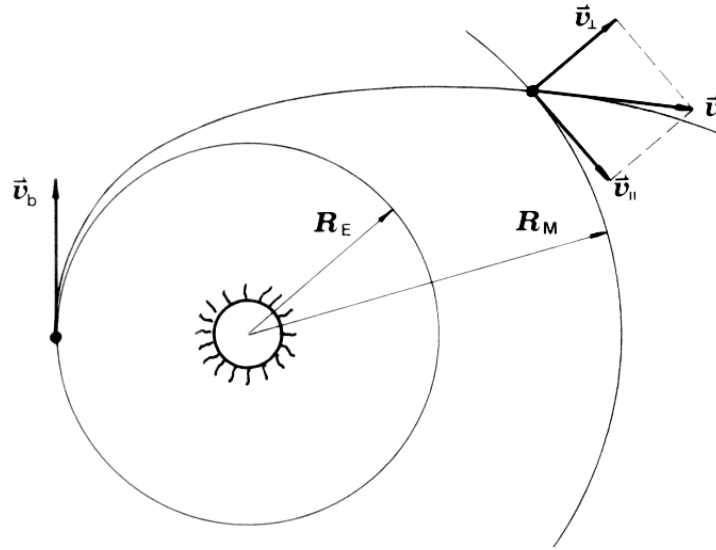

Fig. 8

c) The minimum velocity of the probe in the Mars' system of reference to escape from the Solar system, is $v_s'' = v_M(\sqrt{2} - 1)$, in the direction parallel to the Mars orbit (v_M is the Mars velocity around the Sun). The role of Mars is therefore to change the velocity of the probe so that it leaves its gravitational field with this velocity.

(1 p.)

In the Mars' system, the energy of the probe is conserved. That is, however, not true in the Sun's system in which this encounter can be considered as an elastic collision between Mars and the probe. The velocity of the probe before it enters the gravitational field of Mars is therefore, in

the Mars' system, equal to the velocity with which the probe leaves its gravitational field. The components of the former velocity are $v''_{\perp} = v_{\perp}$ and $v''_{\parallel} = v_{\parallel} - v_M$, hence:

$$v'' = \sqrt{v''_{\parallel}{}^2 + v''_{\perp}{}^2} = \sqrt{v_{\perp}^2 + (v_{\parallel} - v_M)^2} = v'_s. \quad (1p.)$$

Using the expressions for v_{\perp} and v_{\parallel} from (b), we can now find the relation between the launching velocity from the Earth, v'_b , and the velocity v'_s , $v'_s = v_M(\sqrt{2} - 1)$:

$$(v'_b + v_E)^2(1 - k^2) - 2v_E^2(1 - k) + (v'_b + v_E)^2k^2 - 2v_M(v'_b + v_E)k = v_M^2(2 - 2\sqrt{2}).$$

The velocity of Mars round the Sun is $v_M = \sqrt{GM/R_M} = \sqrt{k} v_E$, and the equation for v'_b takes the form:

$$(v'_b + v_E)^2 - 2\sqrt{k}^3 v_E(v'_b + v_E) + (2\sqrt{2}k - 2)v_E^2 = 0. \quad (1p.)$$

The physically relevant solution is:

$$v'_b = v_E \left[\sqrt{k}^3 - 1 + \sqrt{k^3 + 2 - 2\sqrt{2}k} \right] = 5.5 \text{ km/s}. \quad (1p.)$$

d) The fractional saving of energy is:

$$\frac{W_a - W_b}{W_a} = \frac{v'_a{}^2 - v'_b{}^2}{v'_a{}^2} = 0.80,$$

where W_a and W_b are the energies of launching in scheme (i) and in scheme (ii), respectively. (1 p.)

2.2 Experimental competition

Exercise A

The plot of the angle as a function of time for a typical measurement of the acceleration of the disk is shown in Fig. 9.

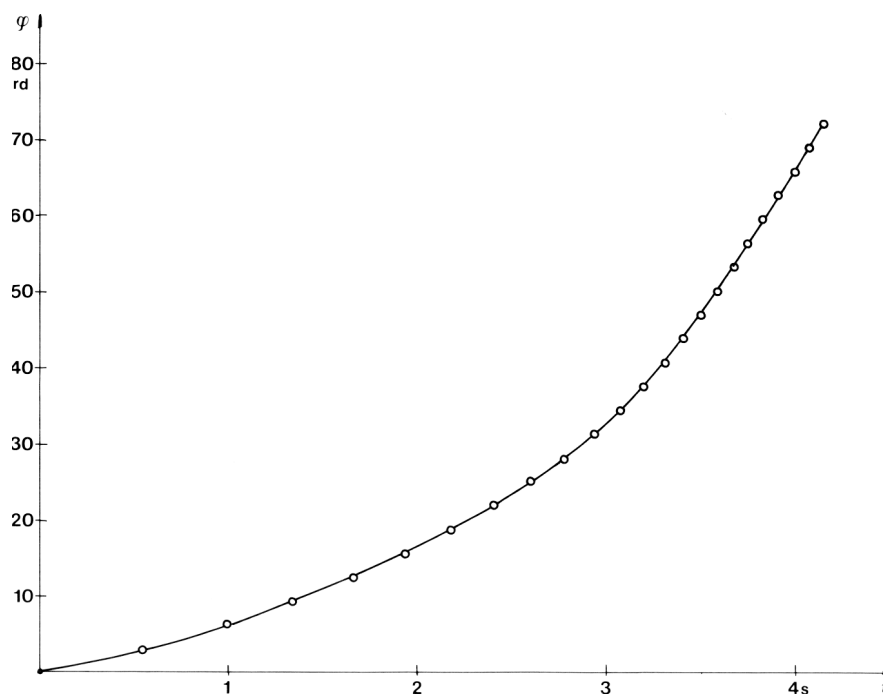

Fig. 9 Angle vs. time

The angular velocity is calculated using the formula:

$$\omega_i(t'_i) = \frac{\pi}{(t_{i+1} - t_i)}$$

and corresponds to the time in the middle of the interval (t_i, t_{i+1}) : $t'_i = \frac{1}{2}(t_{i+1} + t_i)$. The calculated values are displayed in Table 1 and plotted in Fig. 10.

Observing the time intervals of half turns when the constant angular velocity is reached, one can conclude that the iron pegs are not positioned perfectly symmetrically. This systematic error can be neglected in the calculation of angular velocity, but not in the calculation of angular acceleration. To avoid this error we use the time intervals of full turns:

$$\alpha_i(t''_i) = \frac{\Delta\omega_i}{\Delta t_i},$$

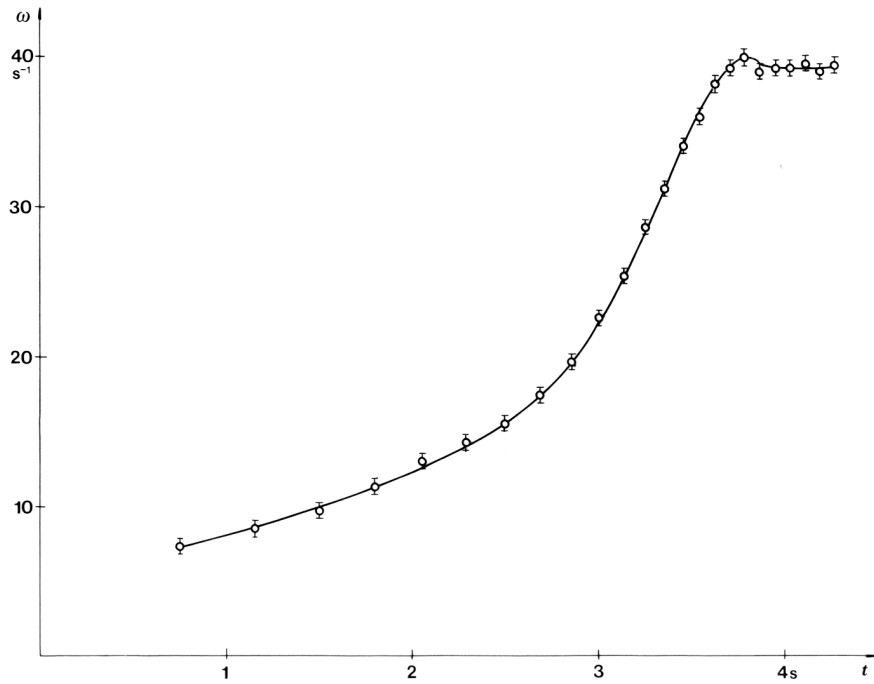

Fig. 10 Angular velocity vs. time

where $\Delta t_i = t_{2i+2} - t_{2i}$,

$$\Delta\omega_i = \frac{2\pi}{(t_{2i+3} - t_{2i+1})} - \frac{2\pi}{(t_{2i+1} - t_{2i-1})}$$

and $t_i'' = t'_{2i+1}$.

The angular acceleration as a function of time is plotted in Fig. 11.

The torque, M , and the power, P , necessary to drive the disk (net torque and net power), are calculated using the relation:

$$M(t) = I\alpha(t)$$

and

$$P(t) = M(t)\omega(t)$$

where the moment of inertia, $I = (14.0 \pm 0.5) \cdot 10^{-6} \text{ kgm}^2$, is given. The corresponding angular velocity is determined from the plot in Fig. 10 by interpolation. This plot is used also to find the torque and the power as functions of angular velocity (Fig. 12 and 13).

i	t ms	δt ms	φ rd	t' ms	ω s^{-1}	α s^{-2}
1	0.0		0.0			
2	543.9	543.9	3.14	272.0	5.78	
3	973.5	429.6	6.28	758.7	7.31	3.38
4	1339.0	365.5	9.42	1156.3	8.60	
5	1660.8	327.8	12.57	1499.9	9.76	5.04
6	1936.3	275.5	15.71	1798.6	11.40	
7	2177.8	241.5	18.85	2057.1	13.01	5.96
8	2396.6	218.8	21.99	2287.2	14.36	
9	2599.6	203.0	25.73	2498.1	15.48	9.40
10	2779.5	179.9	28.27	2689.6	17.46	
11	2939.3	159.8	31.42	2859.4	19.66	18.22
12	3078.0	138.7	34.56	3008.6	22.65	
13	3201.8	123.8	37.70	3139.9	25.38	25.46
14	3311.4	109.6	40.84	3256.6	28.66	
15	3472.1	100.7	43.98	3361.8	31.20	26.89
16	3504.2	92.1	47.12	3458.2	34.11	
17	3591.3	87.1	50.27	3547.8	36.07	21.72
18	3673.4	82.1	53.41	3632.4	38.27	
19	3753.5	80.1	56.55	3713.5	39.22	4.76
20	3832.7	78.6	59.69	3792.8	39.97	
21	3912.6	80.5	62.83	3872.4	39.03	-1.69
22	3992.7	80.1	65.97	3952.7	39.22	
23	4072.8	80.1	69.12	4032.8	39.22	0.77
24	4152.0	79.2	72.26	4112.4	39.67	
25	4232.5	80.5	75.40	4192.3	39.03	-0.15
26	4312.3	79.7	78.54	4272.4	39.42	

Table 1

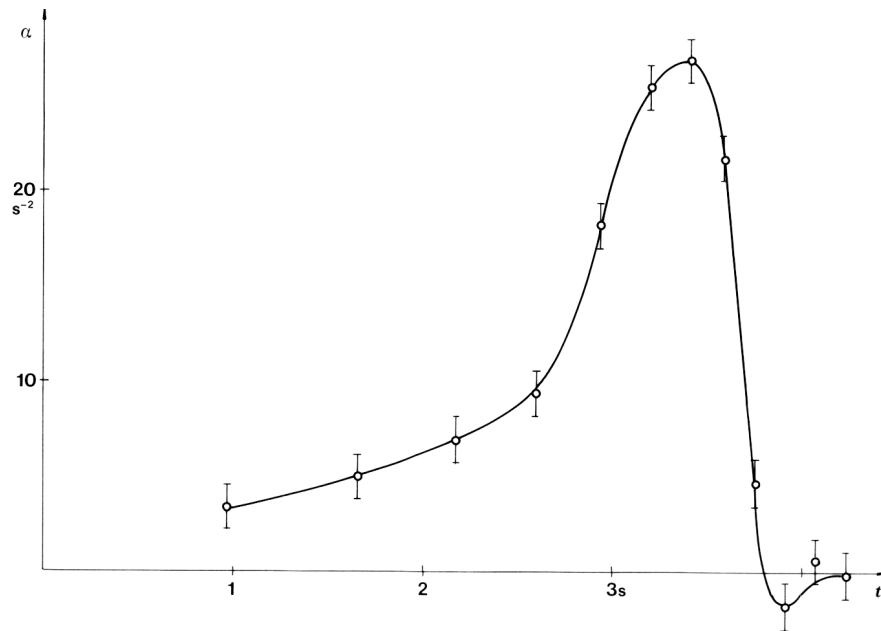

Fig. 11 Angular acceleration vs. time

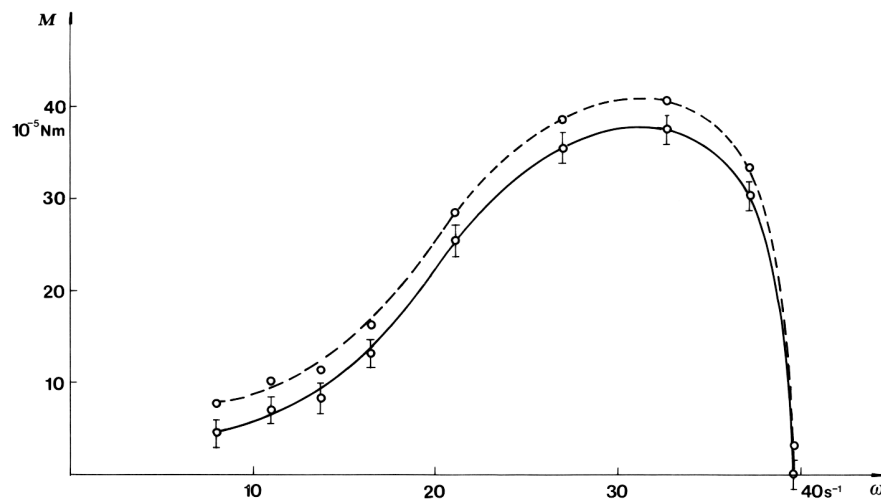

Fig. 12 Net torque (full line) and total torque (dashed line) vs. angular velocity

To find the total torque and the power of the motor, the torque and the power losses due to the friction forces have to be determined and added to the corresponding values of net torque and power. By measuring the angular velocity during the deceleration of the disk after the motor has

been switched off (Fig. 14), we can determine the torque of friction which is approximately constant and is equal to $M' = (3.1 \pm 0.3) \cdot 10^{-5}$ Nm.

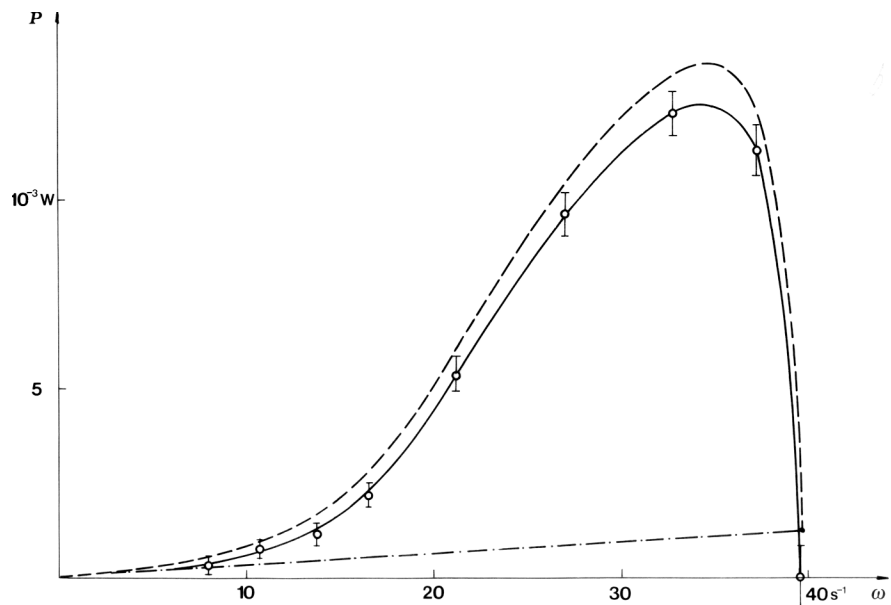

Fig. 13 Net power (full line), power losses (dashed and dotted line) and total power (dashed line) vs. angular velocity

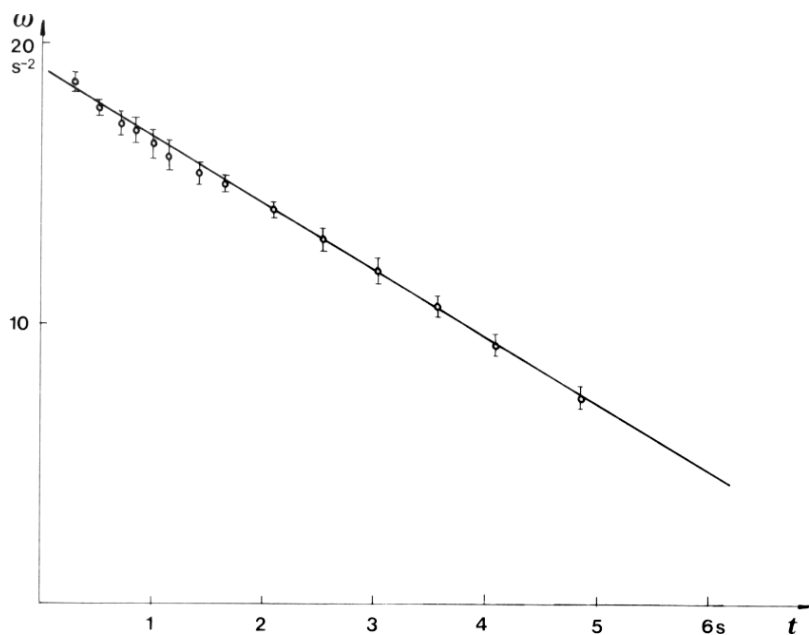

Fig. 14 Angular velocity vs. time during deceleration

The total torque and the total power are shown in Fig. 12 and 13.

Marking scheme

- a) Determination of errors 1 p.
- b) Plot of angle vs. time 1 p.
- c) Plot of angular velocity and acceleration 3 p.
- d) Correct times for angular velocity 1 p.
- e) Plot of net torque vs. angular velocity 2 p. (Plot of torque vs. time only, 1 p.)
- f) Plot of net power vs. angular velocity 1 p.
- g) Determination of friction 1 p.

Exercise B

Two permanent magnets having the shape of rectangular parallelepipeds with sides 50 mm, 20 mm and 8 mm are hidden in a block of polystyrene foam with dimension 50 cm, 31 cm and 4.0 cm. Their sides are parallel to the sides of the block. One of the hidden magnets (A) is positioned so that its \vec{B} (Fig. 15) points in z direction and the other (B) with its \vec{B} in x or y direction (Fig. 15).

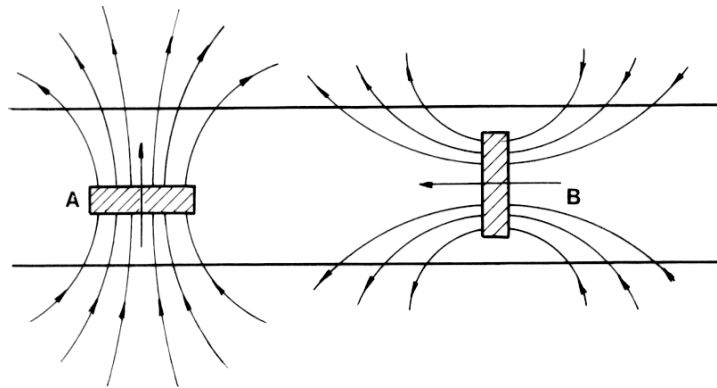

Fig. 15 A typical implementation of the magnets in the block

The positions and the orientations of the magnets should be determined on the basis of observations of forces acting on the extra magnet. The best way to do this is to hang the extra magnet on the thread and move it above the surface to be explored. Three areas of strong forces are revealed when the extra magnet is in the horizontal position i. e. its \vec{B} is parallel to z axis, suggesting that three magnets are hidden. Two of these areas producing an attractive force in position P (Fig. 16) and a repulsive force in position R are closely together.

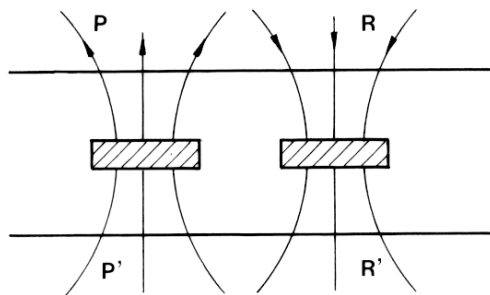

Fig: 16 Two 'ghost' magnets appearing in the place of magnet B

However, by inspecting the situation on the other side of the block, again an attractive force in area P' is found, and a repulsive one in area R'. This is in the contradiction with the supposed magnets layout in Fig. 16 but corresponds to the force distribution of magnet B in Fig. 15.

To determine the z position of the hidden magnets one has to measure the z component of \vec{B} on the surface of the block and compare it to the measurement of B_z of the extra magnet as a function of distance from its center (Fig. 18). To achieve this the induction coil of the measuring system is removed from the point in which the magnetic field is measured to a distance in which the magnetic field is practically zero, and the peak voltage is measured.

In order to make the absolute calibration of the measuring system, the response of the system to the known magnetic field should be measured. The best defined magnetic field is produced in the gap between two field generating coils. The experimental layout is displayed in Fig. 17.

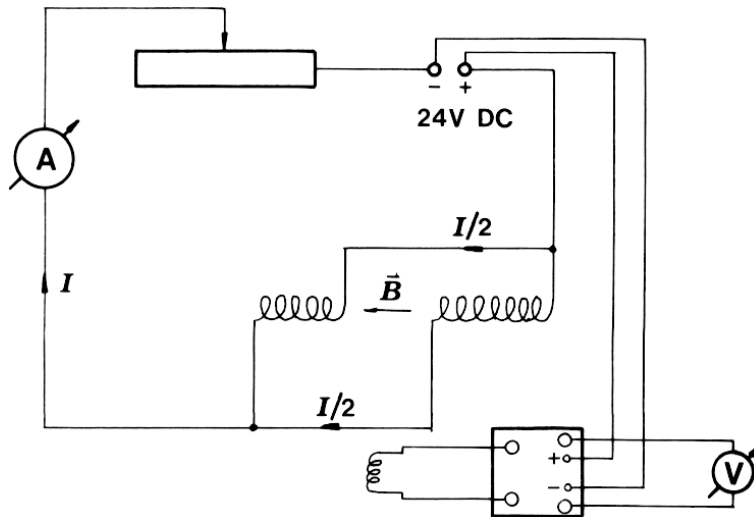

Fig. 17 Calibration of the measuring system

The magnetic induction in the gap between the field generating coils is calculated using the formula:

$$B = \frac{\mu_0 N I}{(2l + d)}$$

Here N is the number of the turns of one of the coils, l its length, d the width of the gap, and I the current through the ammeter. The peak voltage, U , is measured when the induction coil is removed from the gap.

Plotting the magnetic induction B as a function of peak voltage, we can determine the sensitivity of our measuring system:

$$\frac{B}{U} = 0.020 \text{ T/V.}$$

(More precise calculation of the magnetic field in the gap, which is beyond the scope of the exercise, shows that the true value is only 60 % of the value calculated above.)

The greatest value of B is 0.21 T.

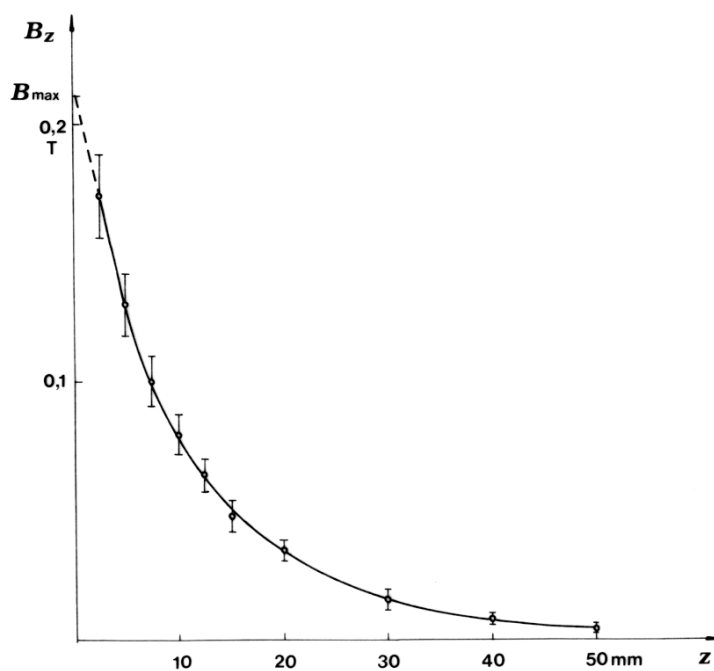

Fig. 18 Magnetic induction vs. distance

Marking scheme:

- a) determination of x, y position of magnets (± 1 cm) 1 p.
- b) determination of the orientations 1 p.
- c) depth of magnets (± 4 mm) 2 p.
- d) calibration (± 50 %) 3 p.
- e) mapping of the magnetic field 2 p.
- f) determination of B_{\max} (± 50 %) 1 p.

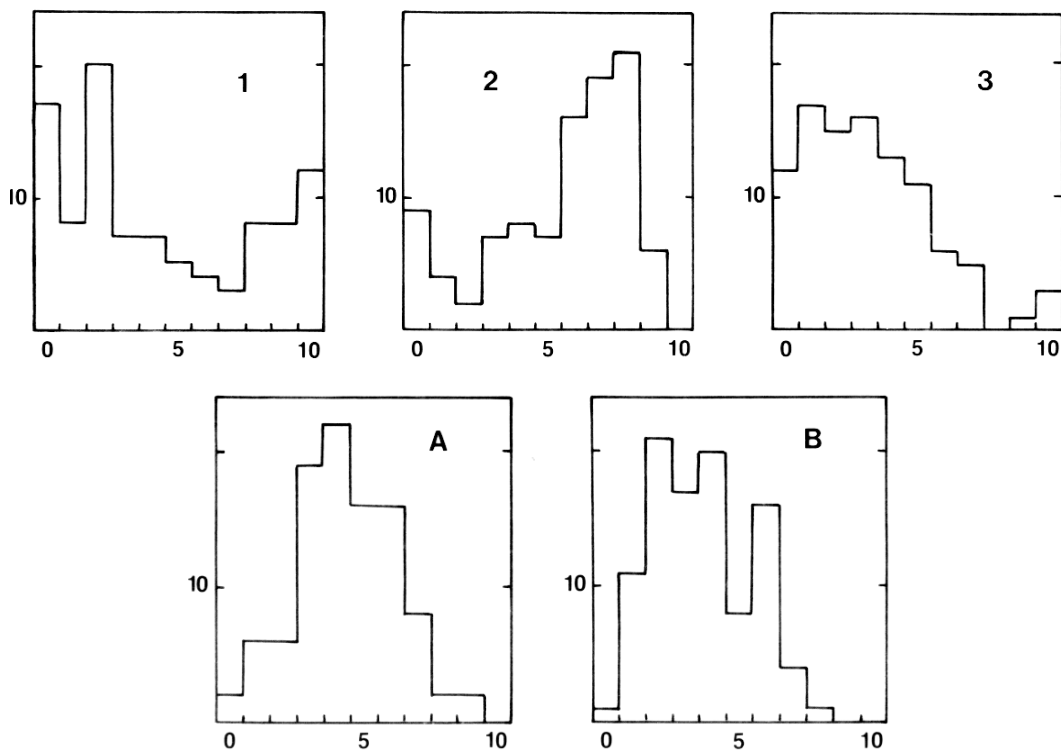
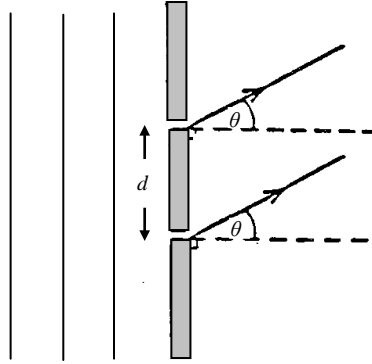

Fig. 19 Distribution of marks for the theoretical (1,2,3) and the experimental exercises. The highest mark for each exercise is 10 points.

Q1

Figure 1.1



A plane monochromatic light wave, wavelength λ and frequency f , is incident normally on two identical narrow slits, separated by a distance d , as indicated in Figure 1.1. The light wave emerging at each slit is given, at a distance x in a direction θ at time t , by

$$y = a \cos[2\pi(ft - x/\lambda)]$$

where the amplitude a is the same for both waves. (Assume x is much larger than d).

(i) Show that the two waves observed at an angle θ to a normal to the slits, have a resultant amplitude A which can be obtained by adding two vectors, each having magnitude a , and each with an associated direction determined by the phase of the light wave.

Verify geometrically, from the vector diagram, that

$$A = 2a \cos \theta$$

where

$$\beta = \frac{\pi}{\lambda} d \sin \theta$$

(ii) The double slit is replaced by a diffraction grating with N equally spaced slits, adjacent slits being separated by a distance d . Use the vector method of adding amplitudes to show that the vector amplitudes, each of magnitude a , form a part of a regular polygon with vertices on a circle of radius R given by

$$R = \frac{a}{2 \sin \beta},$$

Deduce that the resultant amplitude is

$$\frac{a \sin N\beta}{\sin \beta}$$

and obtain the resultant phase difference relative to that of the light from the slit at the edge of the grating.

(iii) Sketch, in the same graph, $\sin N\beta$ and $(1/\sin\beta)$ as a function of β . On a separate graph show how the intensity of the resultant wave varies as a function of β .

(iv) Determine the intensities of the principal intensity maxima.

(v) Show that the number of principal maxima cannot exceed

$$\left(\frac{2d}{\lambda} + 1\right)$$

(vi) Show that two wavelengths λ and $\lambda + \delta\lambda$, where $\delta\lambda \ll \lambda$, produce principal maxima with an angular separation given by

$$\Delta\theta = \frac{n\Delta\lambda}{d \cos\theta} \quad \text{where } n = 0, \pm 1, \pm 2, \dots \text{etc}$$

Calculate this angular separation for the sodium D lines for which

$$\lambda = 589.0\text{nm}, \quad \lambda + \Delta\lambda = 589.6\text{nm}, \quad n = 2, \quad \text{and } d = 1.2 \times 10^{-6} \text{ m.}$$

$$\left[\text{reminder: } \cos A + \cos B = 2 \cos\left(\frac{A+B}{2}\right) \cos\left(\frac{A-B}{2}\right) \right]$$

Q2

International Physics Olympiad 1956

2. Early this century a model of the earth was proposed in which it was assumed to be a sphere of radius R consisting of a homogeneous isotropic solid mantle down to radius R_c . The core region within radius R_c contained a liquid. Figure 2.1

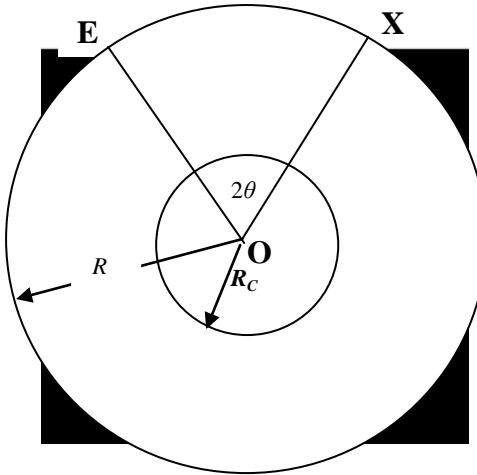

Figure 2.1

The velocities of longitudinal and transverse seismic waves P and S waves respectively, are constant, V_P , and V_S within the mantle. In the core, longitudinal waves have a constant velocity V_{CP} , $< V_P$, and transverse waves are not propagated.

An earthquake at E on the surface of the Earth produces seismic waves that travel through the Earth and are observed by a surface observer who can set up his seismometer at any point X on the Earth's surface. The angular separation between E and X, 2θ given by

$$2\theta = \text{Angle } EOX$$

where O is the centre of the Earth.

(i) Show that the seismic waves that travel through the mantle in a straight line will arrive at X at a time t (the travel time after the earthquake), is given by

$$t = \frac{2R \sin \theta}{v}, \quad \text{for } \theta > \arccos \left[\frac{R_c}{R} \right],$$

where $v = v_P$ for the P waves and $v = v_S$ for the S waves.

(ii) For some of the positions of X such that the seismic P waves arrive at the observer after two refractions at the mantle-core interface. Draw the path of such a seismic P wave. Obtain a relation between θ and i , the angle of incidence of the seismic P wave at the mantle-core interface, for P waves.

(iii) Using the data

$$\begin{aligned}
 R &= 6370 \text{ km} \\
 R_C &= 3470 \text{ km} \\
 v_{CP} &= 10.85 \text{ km s}^{-1} \\
 v_S &= 6.31 \text{ km s}^{-1} \\
 v_{CP} &= 9.02 \text{ km s}^{-1}
 \end{aligned}$$

and the result obtained in (ii), draw a graph of θ against i . Comment on the physical consequences of the form of this graph for observers stationed at different points on the Earth's surface.

Sketch the variation of the travel time taken by the P and S waves as a function of θ for $0 \leq \theta \leq 90$ degrees.

(iv) After an earthquake an observer measures the time delay between the arrival of the S wave, following the P wave, as 2 minutes 11 seconds. Deduce the angular separation of the earthquake from the observer using the data given in Section (iii).

(v) The observer in the previous measurement notices that some time after the arrival of the P and S waves there are two further recordings on the seismometer separated by a time interval of 6 minutes 37 seconds. Explain this result and verify that it is indeed associated with the angular separation determined in the previous section.

Q3

Three particles, each of mass m , are in equilibrium and joined by unstretched massless springs, each with Hooke's Law spring constant k . They are constrained to move in a circular path as indicated in Figure 3.1.

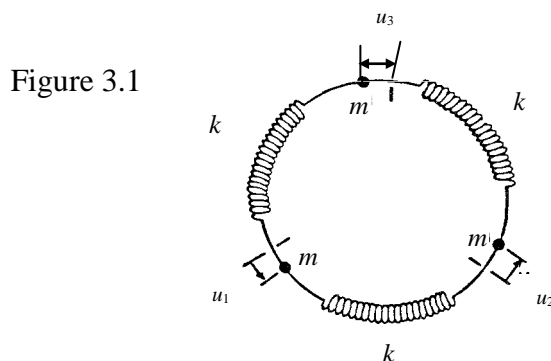

(i) If each mass is displaced from equilibrium by small displacements u_1 , u_2 and u_3 respectively, write down the equation of motion for each mass.

(ii) Verify that the system has simple harmonic solutions of the form

$$u_n = a_n \cos \omega t ,$$

with accelerations, $(-\omega^2 u_n)$ where a_n ($n=1,2,3$) are constant amplitudes, and ω , the angular frequency, can have 3 possible values,

$$\omega_o \sqrt{3}, \omega_o \sqrt{3} \text{ and } 0. \text{ where } \omega_o^2 = \frac{k}{m} .$$

(iii) The system of alternate springs and masses is extended to N particles, each mass m is joined by springs to its neighbouring masses. Initially the springs are unstretched and in equilibrium. Write down the equation of motion of the n th mass ($n = 1, 2, \dots, N$) in terms of its displacement and those of the adjacent masses when the particles are displaced from equilibrium.

$$u_n(t) = a_s \sin\left(\frac{2ns\pi}{N} + \phi\right) \cos \omega_s t,$$

are oscillatory solutions where $s = 1, 2, \dots, N$, $n = 1, 2, \dots, N$ and where ϕ is an arbitrary phase, providing the angular frequencies are given by

$$\omega_s = 2\omega_o \sin\left(\frac{s\pi}{N}\right),$$

where a_s ($s = 1, \dots, N$) are constant amplitudes independent of n .

State the range of possible frequencies for a chain containing an infinite number of masses.

(iv) Determine the ratio

$$u_n / u_{n+1}$$

for large N , in the two cases:

(a) low frequency solutions

(b) $\omega = \omega_{\max}$, where ω_{\max} is the maximum frequency solution.

Sketch typical graphs indicating the displacements of the particles against particle number along the chain at time t for cases (a) and (b).

(v) If one of the masses is replaced by a mass $m' \ll m$ estimate any major change one would expect to occur to the angular frequency distribution.

Describe qualitatively the form of the frequency spectrum one would predict for a diatomic chain with alternate masses m and m' on the basis of the previous result.

Reminder

$$\sin(A + B) = \sin A \cos B + \cos A \sin B$$

$$\sin A + \sin B = 2 \sin\left(\frac{A+B}{2}\right) \cos\left(\frac{A-B}{2}\right)$$

$$2 \sin^2 A = 1 - \cos 2A$$

1986 INTERNATIONAL PHYSICS
OLYMPIAD

EXPERIMENT 1.

2½ hrs

APPARATUS

1. Spectrometer with collimator and telescope.
2. 3 syringes; one for water, one for liquid *A* and one for liquid *B*.
3. A beaker of water plus two sample tubes containing liquids *A* and *B*.
4. 3 retort stands with clamps.
5. 12V shielded source of white light.
6. Black card, plasticine, and black tape.
7. 2 plastic squares with holes to act as stops to be placed over the ends of the telescope, with the use of 2 elastic bands.
8. Sheets of graph paper.
9. Three dishes to collect water plus liquids *A* and *B* lost from syringes.

Please complete synopsis sheet in addition to answering this experimental problem.

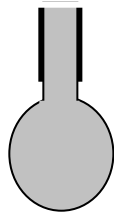

Pendant drop

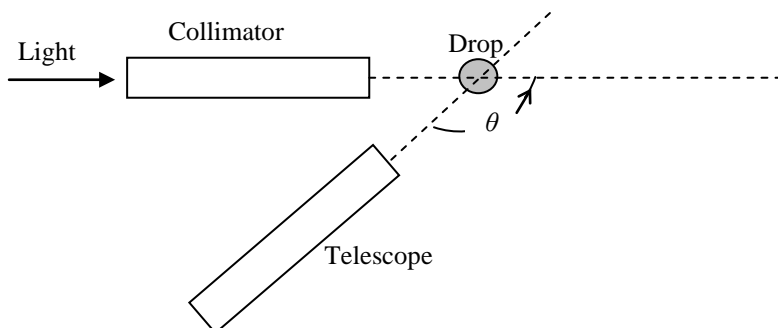

Plan of Apparatus

INSTRUCTIONS AND INFORMATION

1. Adjust collimator to produce parallel light. This may be performed by the following sequence of operations:

- (a) Focus the telescope on a distant object, using adjusting knob on telescope, so that the cross hairs and object are both in focus.
- (b) Position the telescope so that it is opposite the collimator with slit illuminated so that the slit can be viewed through the telescope.
- (c) Adjust the position of the collimator lens, using the adjusting knob on the collimator, so that the image of the slit is in focus on the cross hairs of the telescope's eyepiece.
- (d) Lock the spectrometer table, choosing an appropriate 'zero' on the vernier scale, so that subsequent angular measurements of the telescope's position can conveniently be made.

2. Remove the eyepiece from telescope and place black plastic stops symmetrically over both ends of the telescope, using the elastic bands, so that the angle of view is reduced.

3. Open up collimator slit.

4. Use the syringes to suspend, vertically, a pendant drop symmetrically above the centre of the spectrometer table so that it is fully illuminated by the light from the collimator and can be viewed by telescope.

5. The central horizontal region of the suspended drop will produce rainbows as a result of two reflections and k ($k = 1, 2, \dots$) internal reflections of the light. The first order rainbow corresponds to one internal reflection. The second order rainbow corresponds to two internal reflections. The k 'th order rainbow corresponds to k internal reflections. Each rainbow contains all the colours of the spectrum. These can be observed directly by eye and their angular positions can be accurately measured using the telescope. Each rainbow is due to white light rays incident on the drop at a well determined angle of incidence, that is different for each rainbow.

6. The first order rainbow can be recognized as it has the greatest intensity and appears on the right hand* side of the drop. The second order rainbow appears with the greatest intensity on the left hand* side of the drop. These two rainbows are within an angular separation of 20° of each other for water droplets. The weak intensity fifth order rainbow can be observed on the right hand side of the drop located somewhere between the other two, 'blue', extreme ends of the first and second order rainbows.

7. Light reflected directly from the external surface of the drop and that refracted twice but not internally reflected, will produce bright white glare spots that will hinder observations.

8. The refractive indices, n , of the liquids are:

Water	$n_w = 1.333$
Liquid A	$n_A = 1.467$
Liquid B	$n_B = 1.534$

In addition to the experimental report please complete the summary sheet.

Footnote: This statement is correct if the collimator is to the left of the telescope, as indicated in the diagram. If the collimator is on the righthand side of the telescope the first order rainbow will appear on the lefthand side of the drop and the second order rainbow on the righthand side of the drop.

Measurements

1) Observe, by eye, the first and second order water rainbows. Measure the angle θ through which the telescope has to be rotated, from the initial direction for observing the parallel light from the collimator, to observe, using a pendant water droplet, the red light at the extreme end of the visible spectrum from:

- (a) the first order rainbow on the right of the drop ($k = 1$);
- (b) the second order rainbow on the left of the drop ($k = 2$);
- (c) the weak fifth order rainbow ($k = 5$), between the first and second order rainbows.

One of these angles may not be capable of measurement by the rotation of the telescope due to the mechanical constraints limiting the range of θ . If this is found to be the case, use a straight edge in place of the telescope to measure θ .

(Place the appropriate dish on the spectrometer table to catch any falling droplets.)

Deduce the angle of deviation, ϕ , that is the angle the incident light is rotated by the two reflections and k reflections at the drop's internal surface, for (a), (b) and (c). Plot a graph of ϕ against k .

2. Determine ϕ for the second order rainbows produced by liquids A and B using the red visible light at the extreme end of the visible spectrum. (Place respective dishes on table below to catch any falling liquid as the quantities of liquid are limited).

Using graph paper plot $\cos \frac{\phi}{6}$ against $\frac{1}{n}$, n being the refractive index, for all three liquids and insert the additional point for $n = 1$. Obtain the best straight line through these points; measure its gradient and the value of ϕ for which $n = 2$.

EXPERIMENT 2

Apparatus
RML Nimbus computer

Ten sheets of graph paper.

Please complete synopsis sheet in addition to answering this experimental problem.

THIS IS A TWO AND A HALF HOUR EXAMINATION**INFORMATION**

The microcomputer has been programmed to solve the Newtonian equations of motion for a two-dimensional system of 25 interacting particles, in the xy plane. It is able to generate the positions and velocities of all particles at discrete, equally spaced time intervals. By depressing appropriate keys (which will be described), access to dynamic information about the system can be obtained.

The system of particles is confined to a box which is initially (at time $t = 0$) arranged in a two-dimensional square lattice. A picture of the system is displayed on the screen together with the numerical data requested. All particles are identical; the colours are to enable the particles to be distinguished. As the system evolves in time the positions and velocities of the particles will change. If a particle is seen to leave the box the program automatically generates a new particle that enters the box at the opposite face with the same velocity, thus conserving the number of particles in the box.

Any two particles i and j , separated by a distance r_{ij} interact with a well-defined potential U_{ij} ,

It is convenient to use dimensionless quantities throughout the computation. The quantities given below are used throughout the calculations.

Variable	Symbol
Distance	r^*
Velocity	v^*
Time	t^*
Energy	E^*
Mass of particle	$M^* = 48$
Potential	U_{ij}^*
Temperature	T^*
Kinetic Energy	$E_k^* = \frac{1}{2} m^* v^{*2}$

INSTRUCTIONS

The computer program allows you to access three distinct sets of numerical information and display them on the screen. Access is controlled by the grey function keys on the left-hand side of the keyboard, labelled F1, F2, F3, F4, and F10. These keys should be pressed and released - do not hold down a key, nor press it repeatedly. The program may take up to 1 second to respond.

FIRST INFORMATION SET. PROBLEMS 1 – 5

$$\langle v_x, n \rangle = \frac{1}{25} \sum_{i=1}^{25} (v_{ix}^*)^n$$

$$\langle v_y, n \rangle = \frac{1}{25} \sum_{i=1}^{25} (v_{iy}^*)^n$$

and

$$\langle U \rangle = \frac{1}{25} \sum_{j=1}^{25} \sum_{i=1}^{25} U_{ij}^* \quad (i \neq j)$$

where

v_{ix}^* is the dimensionless x – component of the velocity for the i 'th particle,

v_{iy}^* is the dimensionless y – component of the velocity for the i 'th particle,

and n is an integer with $n \geq 1$.

[Note: the summation over U_{ij}^* excludes the cases in which $i = j$]

After depressing F1 it is necessary to input the integer n ($n \geq 1$) by depressing one of the white keys in the top row of the keyboard, before the information appears on the screen.

The information is displayed in dimensionless time intervals Δt at dimensionless times

$$S \Delta t^{**} \quad (S = 0, 1, 2, \dots)$$

Δt^{**} is set by the computer program to the value $\Delta t^{**} = 0.100000$.

The value of S is displayed at the bottom right hand of the screen. Initially it has the value $S = 0$. The word "waiting" on the screen indicates that the calculation has halted and information concerning the value of S is displayed.

Depressing the long bar (the "space" bar) at the bottom of the keyboard will allow the calculation of the evolution of the system to proceed in time steps Δt^{**} . The current value of S is always displayed on the screen. Whilst the calculation is proceeding the word "running" is displayed on the screen.

Depressing F1 again will stop the calculation at the time integer indicated by S on the screen, and display the current values of

$$\langle v_x, n \rangle, \langle v_y, n \rangle \text{ and } \langle U \rangle$$

after depressing the integer n . The evolution of the system continues on pressing the long bar. The system can, if required, be reset to its original state at $S = 0$ by pressing F10 TWICE.

SECOND INFORMATION SET: PROBLEM 6

Depressing F2 initiates the computer program for the compilation of the histogram in problem 6. This program generates a histogram table of the accumulated number ΔN , of particle velocity components as a function of dimensionless velocity. The dimensionless velocity components, v_x and v_y are referred to collectively by v_c . The dimensionless velocity range is divided into equal intervals $\Delta v_c = 0.05$. The centres of the dimensionless velocity "bins" have magnitudes

$$v_c^* = B \Delta v_c^* \quad (B = 0, \pm 1, \pm 2, \dots)$$

When the long bar on the keyboard is pressed the 2 x 25 dimensionless velocity components are calculated at the current time step, and the program adds one, for each velocity component, into the appropriate velocity 'bin'. This process is continued, for each time step, until F3 is depressed. Once F3 is depressed the (accumulated) histogram is displayed. The accumulation of counts can then be continued by pressing the long bar. (Alternatively if you wish to return to the initial situation, with zero in all bins, press F2).

The accumulation of histogram data should continue for about 200 time steps after initiation.

In the thermodynamic equilibrium the histogram can be approximated by the relation

$$\Delta N = A e^{\left[\frac{-24(v_c^*)^2}{\alpha} \right]}$$

where α is a constant associated with the temperature of the system, and A depends on the total number of accumulated velocity components.

THIRD INFORMATION SET: PROBLEM 7

Depressing F4 followed by the long bar at any time during the evolution of the system will initiate the program for Problem 7. The program will take some 30 seconds, in real time, before displaying a table containing the two

Quantities

$$\langle RX, 2 \rangle = \frac{1}{25} \sum_{i=1}^{25} [x_i^*(S) - x_i^*(SR)]^2$$

and

$$\langle RY, 2 \rangle = \frac{1}{25} \sum_{i=1}^{25} [y_i^*(S) - y_i^*(SR)]^2$$

where x_i^* and y_i^* are the dimensionless position components for the i 'th particle. S is the integer time unit and SR is the fixed initial integer time at which the programme is initiated by depressing F4. It is convenient to introduce integer

$$SZ = S - SR.$$

The programme displays a table of $\langle RX, 2 \rangle$ and $\langle RY, 2 \rangle$ for

$$SZ = 0, 2, 4, \dots, 24.$$

Prior to the display appearing on the screen a notice 'Running' will appear on the screen indicating that a computation is proceeding. Depressing F4, followed by the long bar, again will initiate a new table with SR advanced to the point at which F4 was depressed.

COMPUTATIONAL PROBLEMS

1. Verify that the dimensionless total linear momentum of the system is conserved for the times given by

$$S = 0, 40, 80, 120, 160.$$

State the accuracy of the computer calculation.

2. Plot the variation in dimensionless kinetic energy of the system with time using the time sequence

$$S = 0, 2, 4, 6, 12, 18, 24, 30, 50, 70, 90, 130, 180.$$

3. Plot the variation in dimensionless potential energy of the system with time using the time sequence in 2.

4. Obtain the dimensionless total energy of the system at times indicated in 2. Does the system conserve energy? State the accuracy of the total energy calculation.

5. The system is initially (at $S = 0$) NOT in thermodynamic equilibrium. After a period of time the system reaches thermodynamic equilibrium in which the total dimensionless kinetic energy fluctuates about a mean value of E_k^* . Determine this value of E_k^* and indicate the time, SD , after which the system is in thermodynamic equilibrium.

6. Using the dimensionless accumulated velocity data, during thermodynamic equilibrium, draw up a histogram giving the number ΔN of velocity components against dimensionless velocity component, using the constant velocity component interval $\Delta V_c^* = 0.05$, specified in the table available from the SECOND INFORMATION SET. Data accumulated from approximately 200 time steps should be used and the starting time integer S should be recorded.

Verify that ΔN satisfies the relation

$$\Delta N = Ae^{\left[\frac{24(v_c^*)^2}{\alpha} \right]}$$

where C and A are constants. Determine the value of α .

7. For the system of particles in thermodynamic equilibrium evaluate the average value of R^2 , $\langle R^2 \rangle$, where R is the straight line distance between the position of a particle at a fixed initial time number SR and time number S . The time number difference $SZ = (S - SR)$ takes the values

$$SZ = 0, 2, 4, \dots, 24.$$

Plot $\langle R^2 \rangle$ against SZ for any appropriate value of SR . Calculate the gradient of the function in the linear region and specify the time number range for which this gradient is valid.

In order to improve the accuracy of the plot repeat the previous calculations for three (additional) different values of SR and determine the AVERAGE $\langle R^2 \rangle$ for the four sets of results together with the 'linear' gradient and time number range.

Deduce, with appropriate reasoning, the thermodynamic equilibrium state of the system, either solid or liquid.

Answers Question 1

(i) Vector Diagram

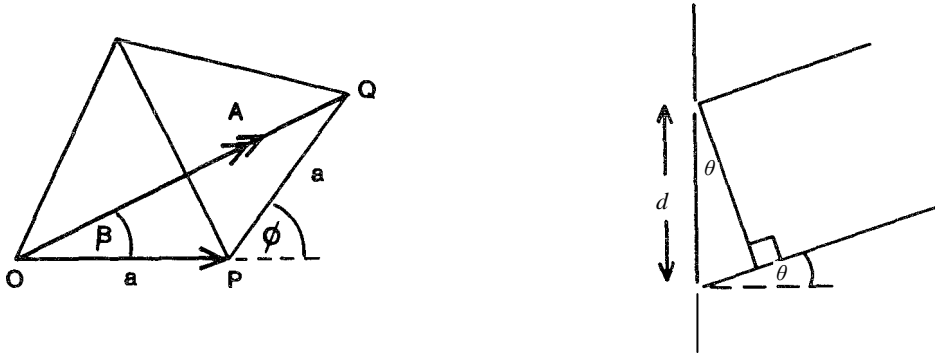

If the phase of the light from the first slit is zero, the phase from second slit is

$$\phi = \frac{2\pi}{\lambda} d \sin \theta$$

Adding the two waves with phase difference ϕ where $\xi = 2\pi\left(ft - \frac{x}{\lambda}\right)$,

$$a \cos(\xi + \phi) + a \cos(\xi) = 2a \cos(\phi/2) \cos(\xi + \phi/2)$$

$$a \cos(\xi + \phi) + a \cos(\xi) = 2a \cos \beta \cos(\xi + \beta)$$

This is a wave of amplitude $A = 2a \cos \beta$ and phase β . From vector diagram, in isosceles triangle OPQ,

$$\beta = \frac{1}{2} \phi = \frac{\pi}{\lambda} d \sin \theta \quad (NB \ \phi = 2\beta)$$

and

$$A = 2a \cos \beta.$$

Thus the sum of the two waves can be obtained by the addition of two vectors of amplitude a and angular directions 0 and ϕ .

- (ii) Each slit in diffraction grating produces a wave of amplitude a with phase 2β relative to previous slit wave. The vector diagram consists of a 'regular' polygon with sides of constant length a and with constant angles between adjacent sides. Let O be the centre of circumscribing circle passing through the vertices of the polygon. Then radial lines such as OS have length R and bisect the internal angles of the polygon. Figure 1.2.

Figure 1.2

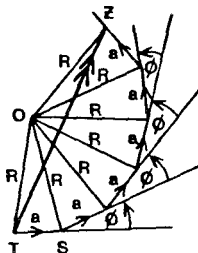

$$\widehat{OST} = \widehat{OTS} = \frac{1}{2}(180 - \phi)$$

$$\text{and } \widehat{TOS} = \phi$$

In the triangle TOS , for example

$$a = 2R \sin(\phi/2) = 2R \sin \beta \text{ as } (\phi = 2\beta)$$

$$\therefore R = \frac{a}{2 \sin \beta} \quad (1)$$

As the polygon has N faces then:

$$\widehat{TOZ} = N(\widehat{TOZ}) = N\phi = 2N\beta$$

Therefore in isosceles triangle TOZ , the amplitude of the resultant wave, TZ , is given by

$$2R \sin N\beta.$$

Hence from (1) this amplitude is

$$\frac{a \sin N\beta}{\sin \beta}$$

Resultant phase is

$$\begin{aligned} &= \widehat{ZTS} \\ &= \widehat{OTS} - \widehat{OTZ} \\ &= \left(90 - \frac{\phi}{2}\right) - \frac{1}{2}(180 - N\phi) \\ &= -\frac{1}{2}(N-1)\phi \\ &= (N-1)\beta \end{aligned}$$

(iii)

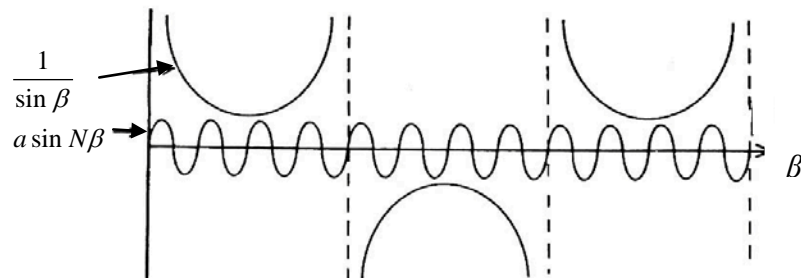

$$\text{Intensity } I = \frac{a^2 \sin^2 N\beta}{\sin^2 \beta}$$

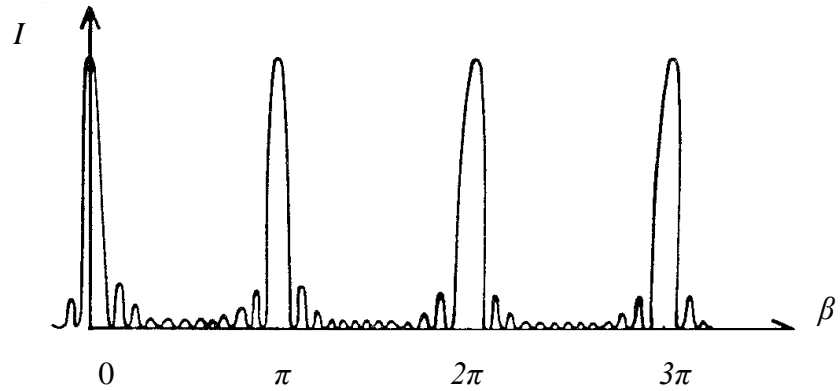

(iv) For the principle maxima $\beta = \pi p$ where $p = 0 \pm 1 \pm 2 \dots$

$$I_{\max} = a^2 \left(\frac{N\beta'}{\beta'} \right) = N^2 a^2 \quad \beta' = 0 \text{ and } \beta = \pi p + \beta'$$

(v) Adjacent max. estimate I_1 :

$$\sin^2 N\beta = 1, \quad \beta = 2\pi p \mp \frac{3\pi}{2N} \text{ i.e. } \beta = \pm \frac{3\pi}{2N}$$

$\left[\beta = \pi p \pm \frac{\pi}{2N} \right]$ does not give a maximum as can be observed from the graph.

$$I_1 = a^2 \frac{1}{\frac{3\pi^2}{2N}} = \frac{a^2 N^2}{23} \text{ for } N \gg 1$$

Adjacent zero intensity occurs for $\beta = \pi p \pm \frac{\pi}{N}$ i.e. $\delta = \pm \frac{\pi}{N}$

For phase differences much greater than δ , $I = a^2 \left(\frac{\sin N\beta}{\sin \beta} \right) = a^2$.

(vi)

$\beta = n\pi$ for a principle maximum

$$\text{i.e. } \frac{\pi}{\lambda} d \sin \theta = n\pi \quad n = 0, \pm 1, \pm 2, \dots$$

Differentiating w.r.t, λ

$$d \cos \theta \Delta \theta = n \Delta \lambda$$

$$\Delta \theta = \frac{n \Delta \lambda}{d \cos \theta}$$

Substituting $\lambda = 589.0 \text{ nm}$, $\lambda + \Delta \lambda = 589.6 \text{ nm}$. $n = 2$ and $d = 1.2 \times 10^{-6} \text{ m}$.

$$\Delta \theta = \frac{n \Delta \lambda}{d \sqrt{1 - \left(\frac{n\lambda}{d} \right)^2}} \text{ as } \sin \theta = \frac{n\lambda}{d} \text{ and } \cos \theta = \sqrt{1 - \left(\frac{n\lambda}{d} \right)^2}$$

$$\Rightarrow \Delta \theta = 5.2 \times 10^{-3} \text{ rads or } 0.30^\circ$$

2.(i)

Figure 2.1

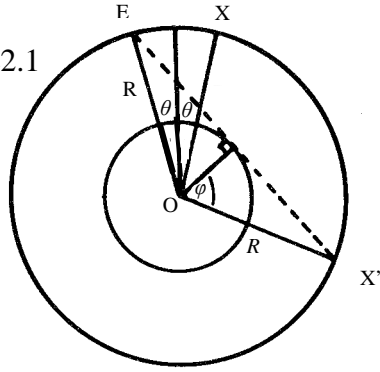

$$EX = 2R \sin \theta \quad \therefore t = \frac{2R \sin \theta}{v}$$

where $v = v_P$ for P waves and $v = v_S$ for S waves.

This is valid providing X is at an angular separation less than or equal to X', the tangential ray to the liquid core. X' has an angular separation given by, from the diagram,

$$2\phi = 2 \cos^{-1} \left(\frac{R_c}{R} \right),$$

Thus

$$t = \frac{2R \sin \theta}{v}, \quad \text{for } \theta \leq \cos^{-1} \left(\frac{R_c}{R} \right),$$

where $v = v_P$ for P waves and $v = v_S$ for shear waves.

(ii) $\frac{R_c}{R} = 0.5447$ and $\frac{v_{CP}}{v_P} = 0.8313$

Figure 2.2

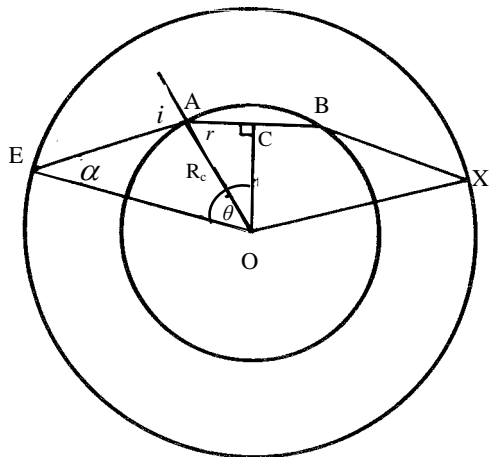

From Figure 2.2

$$\theta = \hat{AOC} + \hat{EOA} \Rightarrow \theta = (90 - r) + (1 - \alpha) \tag{1}$$

(ii) Continued

Snell's Law gives:

$$\frac{\sin i}{\sin r} = \frac{v_P}{v_{CP}} \quad (2)$$

From the triangle EAO, sine rule gives

$$\frac{R_C}{\sin x} = \frac{R}{\sin i} \quad (3)$$

Substituting (2) and (3) into (1)

$$\theta = \left[90 - \sin^{-1} \left(\frac{v_{CP}}{v_P} \sin i \right) + i - \sin^{-1} \left(\frac{R_C}{R} \sin i \right) \right] \quad (4)$$

(iii)

For Information Only

$$\text{For minimum } \theta, \frac{d\theta}{di} = 0. \Rightarrow 1 - \frac{\left(\frac{v_{CP}}{v_P} \right) \cos i}{\sqrt{1 - \left(\frac{v_{CP}}{v_P} \sin i \right)^2}} - \frac{\left(\frac{R_C}{R} \right) \cos i}{\sqrt{1 - \left(\frac{R_C}{R} \sin i \right)^2}} = 0$$

Substituting $i = 55.0^\circ$ gives LHS=0, this verifying the minimum occurs at this value of i . Substituting $i = 55.0^\circ$ into (4) gives $\theta = 75.8^\circ$.

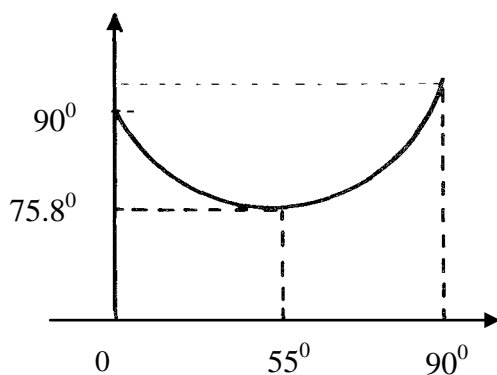
Plot of θ against i .

Substituting into 4:

$$i = 0 \quad \text{gives} \quad \theta = 90$$

$$i = 90^\circ \quad \text{gives} \quad \theta = 90.8^\circ$$

Substituting numerical values for $i = 0 \rightarrow 90^\circ$ one finds a minimum value at $i = 55^\circ$; the minimum values of θ , $\theta_{\text{MIN}} = 75.8^\circ$.

Physical Consequence

As θ has a minimum value of $75 \cdot 8^\circ$ observers at position for which $2\theta < 151 \cdot 6^\circ$ will not observe the earthquake as seismic waves are not deviated by angles of less than $151 \cdot 6^\circ$. However for $2\theta \leq 114^\circ$ the direct, non-refracted, seismic waves will reach the observer.

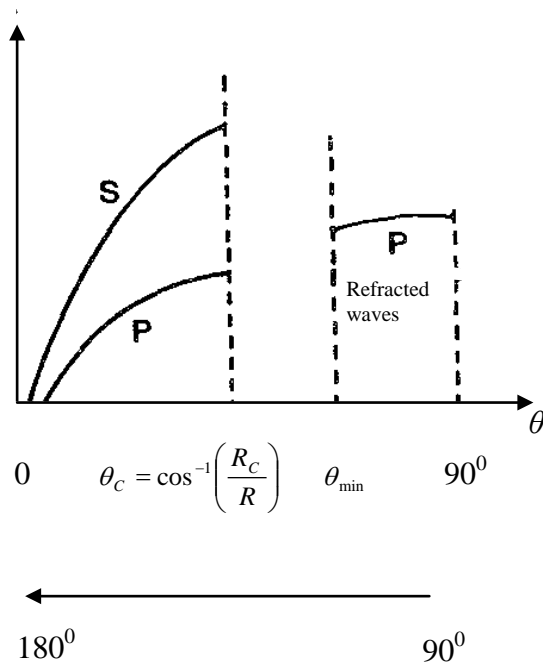

(iv) Using the result

$$t = \frac{2r \sin \theta}{v}$$

the time delay Δt is given by

$$\Delta t = 2R \sin \theta \left[\frac{1}{v_s} - \frac{1}{v_p} \right]$$

Substituting the given data

$$131 = 2(6370) \left[\frac{1}{6.31} - \frac{1}{10.85} \right] \sin \theta$$

Therefore the angular separation of E and X is

$$2\theta = 17.84^\circ$$

This result is less than $2 \cos^{-1}\left(\frac{R_c}{R}\right) = 2 \cos^{-1}\left(\frac{3470}{6370}\right) = 114^\circ$

And consequently the seismic wave is not refracted through the core.

(v)

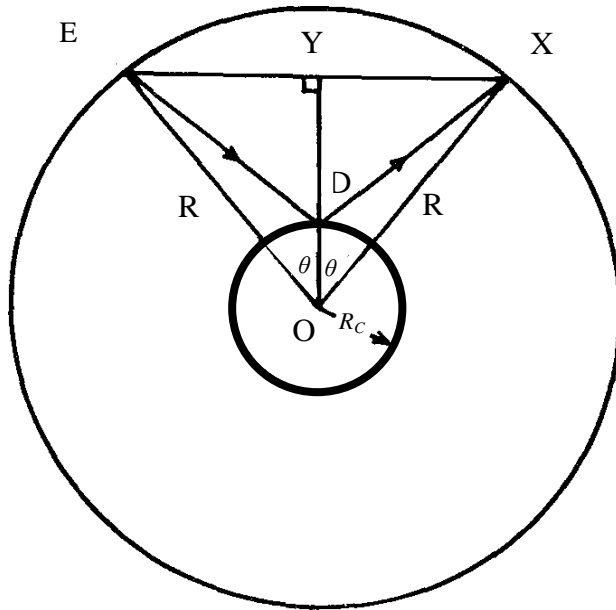

The observations are most likely due to reflections from the mantle-core interface. Using the symbols given in the diagram, the time delay is given by

$$\Delta t' = (ED + DX) \left[\frac{1}{v_s} - \frac{1}{v_p} \right]$$

$$\Delta t' = 2(ED) \left[\frac{1}{v_s} - \frac{1}{v_p} \right] \text{ as } ED = EX \text{ by symmetry}$$

In the triangle EYD,

$$(ED)^2 = (R \sin \theta)^2 + (R \cos \theta - R_C)^2$$

$$(ED)^2 = R^2 + R_C^2 - 2RR_C \cos \theta$$

$$\sin^2 \theta + \cos^2 \theta = 1$$

Therefore

$$\Delta t' = 2\sqrt{R^2 + R_C^2 - 2RR_C \cos \theta} \left[\frac{1}{v_s} - \frac{1}{v_p} \right]$$

Using (ii)

$$\Delta t' = \frac{\Delta t}{R \sin \theta} \sqrt{R^2 + R_C^2 - 2RR_C \cos \theta}$$

$$\Rightarrow 396.7s \text{ or } 6m \ 37s$$

Thus the subsequent time interval, produced by the reflection of seismic waves at the mantle core interface, is consistent with angular separation of 17.84° .

Answer Q3

Equations of motion:

$$m \frac{d^2 u_1}{dt^2} = k(u_2 - u_1) + k(u_3 - u_1)$$

$$m \frac{d^2 u_2}{dt^2} = k(u_3 - u_2) + k(u_1 - u_2)$$

$$m \frac{d^2 u_3}{dt^2} = k(u_1 - u_3) + k(u_2 - u_3)$$

Substituting $u_n(t) = u_n(0) \cos \omega t$ and $\omega_o^2 = \frac{k}{m}$:

$$(2\omega_o^2 - \omega^2)u_1(0) - \omega_o^2 u_2(0) - \omega_o^2 u_3(0) = 0 \quad (a)$$

$$-\omega_o^2 u_1(0) + (2\omega_o^2 - \omega^2)u_2(0) - \omega_o^2 u_3(0) = 0 \quad (b)$$

$$-\omega_o^2 u_1(0) - \omega_o^2 u_2(0) + (2\omega_o^2 - \omega^2)u_3(0) = 0 \quad (c)$$

Solving for $u_1(0)$ and $u_2(0)$ in terms of $u_3(0)$ using (a) and (b) and substituting into (c) gives the equation equivalent to

$$(3\omega_o^2 - \omega^2)^2 \omega^2 = 0$$

$$\omega^2 = 3\omega_o^2, \quad 3\omega_o^2 \text{ and } 0$$

$$\omega = \sqrt{3}\omega_o, \quad \sqrt{3}\omega_o \text{ and } 0$$

(ii) Equation of motion of the n'th particle:

$$m \frac{d^2 u_n}{dt^2} = k(u_{1+n} - u_n) + k(u_{n-1} - u_n)$$

$$n = 1, 2, \dots, N$$

$$\frac{d^2 u_n}{dt^2} = k(u_{1+n} - u_n) + \omega_o^2 (u_{n-1} - u_n)$$

Substituting $u_n(t) = u_n(0) \sin\left(2ns \frac{\pi}{N}\right) \cos \omega_s t$

$$-\omega_s^2 \left(\sin\left(2ns \frac{\pi}{N}\right) \right) = \omega_o^2 \left[\sin\left(2(n+1)s \frac{\pi}{N}\right) - 2 \sin\left(2ns \frac{\pi}{N}\right) + \sin\left(2(n-1)s \frac{\pi}{N}\right) \right]$$

$$-\omega_s^2 \left(\sin\left(2ns \frac{\pi}{N}\right) \right) = 2\omega_o^2 \left[\frac{1}{2} \sin\left(2(n+1)s \frac{\pi}{N}\right) + \sin\left(2ns \frac{\pi}{N}\right) - \frac{1}{2} \sin\left(2(n-1)s \frac{\pi}{N}\right) \right]$$

$$-\omega_s^2 \left(\sin\left(2ns \frac{\pi}{N}\right) \right) = 2\omega_o^2 \left[\sin\left(2ns \frac{\pi}{N}\right) \cos\left(2s \frac{\pi}{N}\right) - \sin\left(2ns \frac{\pi}{N}\right) \right]$$

$$\therefore \omega_s^2 = 2\omega_o^2 \left[1 - \cos\left(2s \frac{\pi}{N}\right) \right] : \quad (s = 1, 2, \dots, N)$$

$$\text{As } 2 \sin^2 \theta = 1 - \cos 2\theta$$

This gives

$$\omega_s = 2\omega_o \sin\left(\frac{s\pi}{N}\right) \quad (s = 1, 2, \dots, N)$$

 ω_s can have values from 0 to $2\omega_o = 2\sqrt{\frac{k}{m}}$ when $N \rightarrow \infty$; corresponding to range $s = 1$ to $\frac{N}{2}$.

(iv) For s'th mode

$$\frac{u_n}{u_{n+1}} = \frac{\sin\left(2ns \frac{\pi}{N}\right)}{\sin\left(2(n+1)s \frac{\pi}{N}\right)}$$

$$\frac{u_n}{u_{n+1}} = \frac{\sin\left(2ns \frac{\pi}{N}\right)}{\sin\left(2ns \frac{\pi}{N}\right) \cos\left(2s \frac{\pi}{N}\right) + \cos\left(2ns \frac{\pi}{N}\right) \sin\left(2s \frac{\pi}{N}\right)}$$

(a) For small ω , $\left(\frac{s}{N}\right) \approx 0$, thus $\cos\left(2ns \frac{\pi}{N}\right) \cong 1$ and $\sin\left(2ns \frac{\pi}{N}\right) \approx 0$, and so $\frac{u_n}{u_{n+1}} \cong 1$.

(b) The highest mode, $\omega_{\max} = 2\omega_o$, corresponds to $s = N/2$

$$\therefore \frac{u_n}{u_{n+1}} = -1 \text{ as } \frac{\sin(2n\pi)}{\sin(2(n+1)\pi)} = -1$$

Case (a)

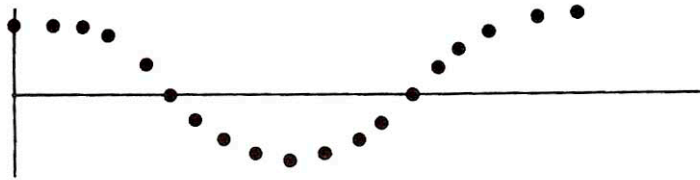

Case (b)
N odd

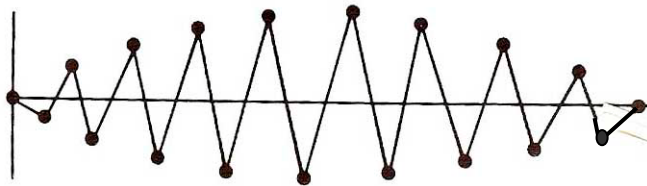

N even

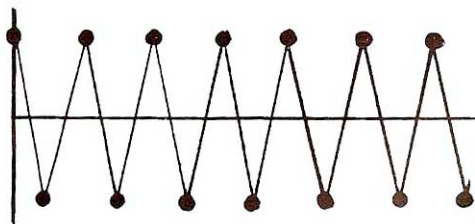

- (vi) If $m' \ll m$, one can consider the frequency associated with m' as due to vibration of m' between two adjacent, much heavier, masses which can be considered stationary relative to m' .

The normal mode frequency of m' , in this approximation, is given by

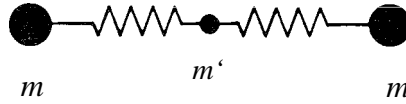

$$m' \ddot{x} = -2kx$$

$$\omega'^2 = \frac{2k}{m'}$$

$$\omega' = \sqrt{\frac{2k}{m'}}$$

For small m' , ω' will be much greater than ω_{\max} ,

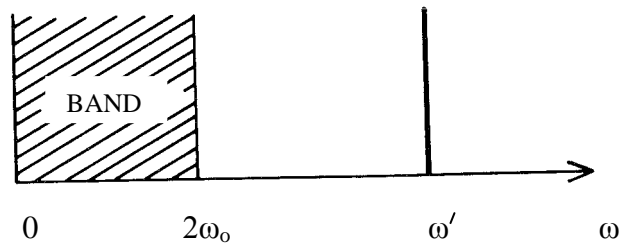

DIATOMIC SYSTEM

More light masses, m' , will increase the number of frequencies in region of ω' giving a band-gap-band spectrum.

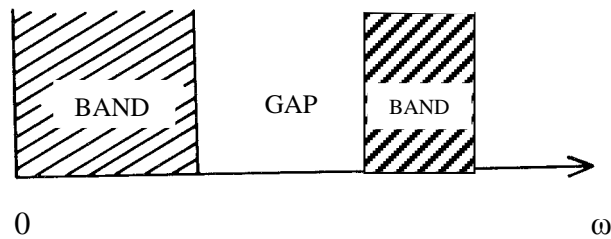

SUMMARY SHEET

EXPERIMENT 1

1. FOR WATER AND RED LIGHT AT EXTREME END OF SPECTRUM

k = 1	First Order Rainbow	$\theta_1 = 129.0^\circ$	$\phi_1 = 137.0 \pm 5.0^\circ$
k = 2	Second Order Rainbow	$\theta_2 = 129.0^\circ$	$\phi_2 = 231.0 \pm 3.0^\circ$
k = 5	Fifth Order Rainbow	$\theta_5 = 126.0^\circ$	$\phi_5 = 486.0 \pm 4.0^\circ$

2. LIQUIDS A AND B USING SECOND ORDER RAINBOWS

For Liquid A	$\theta_2 = 105.0^\circ$	$\phi_2 = 255.0 \pm 3.0^\circ$
For Liquid B	$\theta_2 = 89.5^\circ$	$\phi_2 = 270.5 \pm 3.0^\circ$
For $n = 1$	$\theta_2 = 0.0^\circ$	$\phi_2 = 0.0^\circ$
Gradient of graph		$= 0.84 \pm 0.07$
Extrapolated, $n = 2,$	$\theta_2,$ value of ϕ	$= 304 \pm 25^\circ$

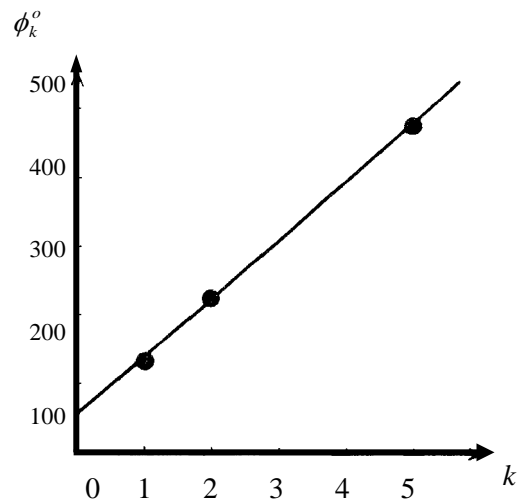

Figure E 1.1.

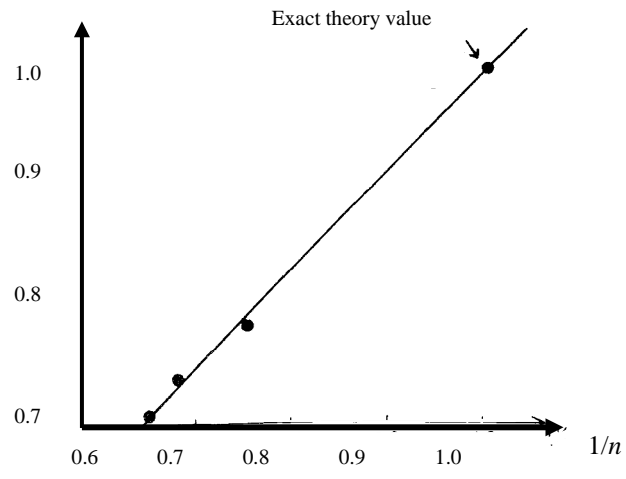

Figure E 1.2

SUMMARY SHEET

EXPERIMENT 2

Is the total momentum conserved?

YES / ~~NO~~

Accuracy of computer calculation

$$100 \frac{0.0000018}{0.1} \approx 0.002\% \text{ 0:1}$$

(RMS velocity = 0.1)

Time	Total Energy
0	-1.61499
2	-1.62886
4	-1.62878
6	-1.62301
12	-1.62882
18	-1.62599
24	-1.62796
30	-1.62703
50	-1.62753
70	-1.62676
90	-1.62580
130	-1.62713
180	-1.62409

Does the system conserve energy?

YES / ~~NO~~ ($\sim \pm 1\%$)Equilibrium value of E_k^* (Average 24 to 180) = 0.534 ± 0.05 Equilibrium time SD (see Fig. E 2.1) $\cong (10 \text{ to } 20) \times 0.1$ Value of S recorded > 20 , e.g. 60Value of α
(for $SD=60$) (see Fig. E2.2) = 0.503Accuracy of α = ± 0.02 For what time number range is graph, obtained using first value of SR , linear? $SZ = 18 \text{ to } 24$

Gradient of this graph in linear region	$\cong 0.027$ to 0.47
Accuracy of gradient	$= 0.002$
Gradient of AVERAGE $\langle R^2 \rangle$ in linear region	$= 0.035$
Accuracy of this gradient	$= \pm 0.01$
* delete as appropriate	
Is the system a liquid/solid?	Liquid/ Solid *

Mean Momentum of the system at requested steps (S)

S	$\langle VX, I \rangle$	$\langle VY, I \rangle$	$\langle PX \rangle$	$\langle PY \rangle$
0	0.0000000	0.0000000	0.000000	0.000000
40	0.0000010	0.0000016	0.000048	0.000077
80	0.0000018	0.0000001	0.000086	0.000005
120	0.0000014	0.0000007	0.000067	0.000034
160	0.0000016	0.0000010	0.000077	0.000048

Energy of the system at requested steps (S)

S	$\langle VX, 2 \rangle$	$\langle VY, 2 \rangle$	$\langle KE \rangle = T^*$	$\langle U \rangle$	$\langle E \rangle =$ Total Energy
0	0.0173874	0.0142851	0.760140	-4.7502660	-1.61499
2	0.0162506	0.0131025	0.704474	-4.6666675	-1.62886
4	0.0124966	0.0089562	0.514867	-4.2873015	-1.62878
6	0.0077405	0.0039113	0.279643	-3.8053113	-1.62301
12	0.0118740	0.0120959	0.575278	-4.4081878	-1.62882
18	0.0099579	0.0075854	0.421039	-4.0940627	-1.62599
24	0.0108577	0.0116978	0.541332	-4.3385782	-1.62796
30	0.0126065	0.0100340	0.543372	-4.3407997	-1.62703
50	0.0127138	0.0103334	0.553133	-4.3613165	-1.62753
70	0.0088657	0.0158292	0.592678	-4.4388669	-1.62676
90	0.0107740	0.0076446	0.442087	-4.1357699	-1.62580
130	0.0073008	0.0177446	0.601090	-4.4564333	-1.62713
180	0.0097161	0.0096426	0.464609	-4.1773882	-1.62409

All values are in reduced units. $\langle KE \rangle$ is the mean kinetic energy per atom. $\langle U^* \rangle$ is twice the potential energy. $\langle VX,2 \rangle$ and $\langle VY,2 \rangle$ are the mean values of the squares of the X and Y velocity components, as described in the question. Similarly $\langle VX,1 \rangle$ and $\langle VY,1 \rangle$ are the mean values of the velocity components. $\langle PX \rangle$ and $\langle PY \rangle$ are the mean momentum per particle.

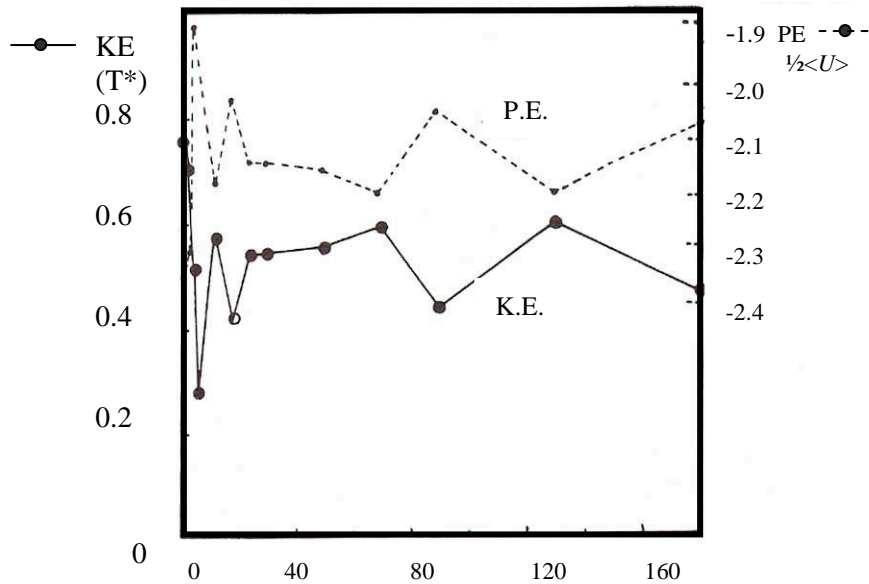
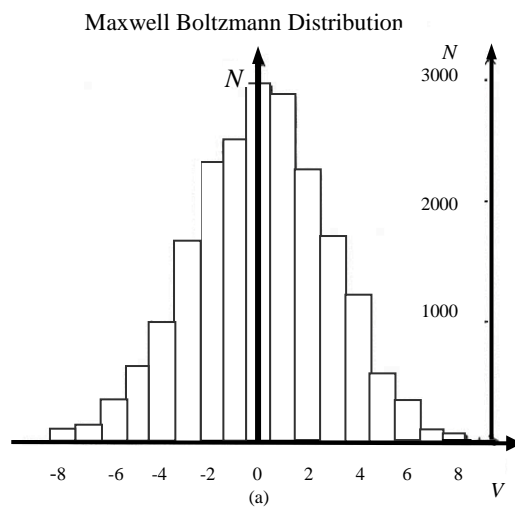
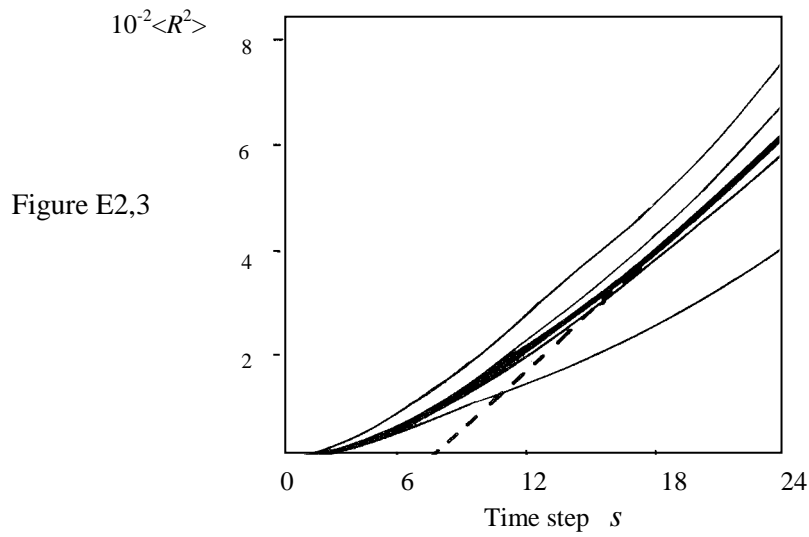
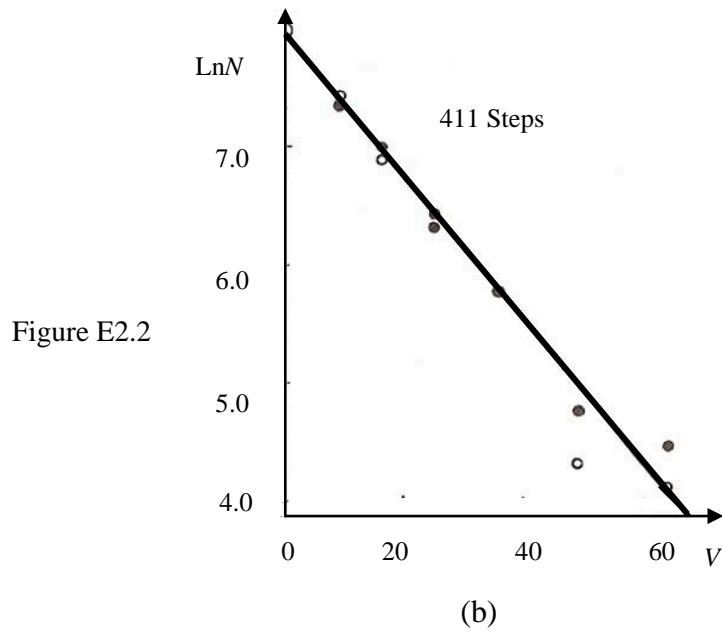

Figure E 2.1

Variation of K.E and P.E.





$\langle R^2 \rangle$ curves as a function of time

TYPICAL RESULTS : NOTE THE LARGE VARIATIONS IN THE VALUES OF $\langle R^2 \rangle$

Time Number SZ - S-SR	SR = 261 <R ² >	SR = 301 <R ² >	SR = 334 <R ² >	SR = 370 <R ² >	AVERAGE <R ² >
0	0	0	0	0	0
2	0.00088	0.00067	0.00091	0.00079	0.00081
4	0.00287	0.00276	0.00382	0.00298	0.00311
6	0.00523	0.00628	0.00858	0.00623	0.00658
8	0.00797	0.01101	0.01449	0.01039	0.01097
10	0.01143	0.01656	0.02095	0.01523	0.01604
12	0.01528	0.02235	0.02768	0.02022	0.02138
14	0.01874	0.02845	0.03453	0.02564	0.02684
16	0.02184	0.03539	0.04157	0.03160	0.03260
18	0.02526	0.04293	0.04902	0.03833	0.03889
20	0.02979	0.05080	0.05718	0.04532	0.04577
22	0.03538	0.05918	0.06605	0.0510	0.05303
24	0.04063	0.06784	0.07533	0.05569	0.05987

Problems of the 18th International Physics Olympiad (Jena, 1987)

Gunnar Friege & Gunter Lind¹

Leibniz-Institute for Science Education (IPN) at the University of Kiel, Germany

Abstract

The 18th International Physics Olympiad took place in 1987 in the German Democratic Republic (GDR). This article contains the competition problems, their solutions and also a (rough) grading scheme.

Introduction

The 18th international Physics olympics in 1987 was the second International Physics Olympiad hosted by the German Democratic Republic (GDR) . The organisation was lead by the ministry for education and the problems were formulated by a group of professors of different universities. However, the main part of the work was done by the physics department of the university of Jena. The company Carl-Zeiss and a special scientific school in Jena were involved also.

In the competition three theoretical and one experimental problem had to be solved. The theoretical part was quite difficult. Only the first of the three problems (“ascending moist air”) had a medium level of difficulty. The points given in the markings were equal distributed. Therefore, there were lots of good but also lots of unsatisfying solutions. The other two theoretical problems were rather difficult. About half of the pupils even did not find an adequate start in solving these problems. The third problem (“infinite LC-grid”) revealed quite a few complete solutions. The high level of difficulty can probably be explained with the fact that many pupils nearly had no experience with the subject. Concerning the second problem (“electrons in a magnetic field”) only a few pupils worked on the last part 3 (see below).

The experimental problem (“refracting indices”) was much more easier than the theoretical problems. There were lots of different possibilities of solution and most of the pupils

¹ Contact: Leibniz-Institute for Science Education (IPN) at the University of Kiel
Olshausenstrasse 62, 24098 Kiel, Germany
ipho@ipn.uni-kiel.de

managed to come up with partial or complete solutions. Over the half of all teams got more points in the experimental part than in the theoretical part of the competition.

The problems and their solutions are based on the original German and English versions of the competition problems. Only minor changes have been made. Despite the fact that nowadays almost all printed figures are generated with the aid of special computer programmes, the original hand-made figures are published here.

Theoretical Problems

Problem 1: Ascending moist air

Moist air is streaming adiabatically across a mountain range as indicated in the figure.

Equal atmospheric pressures of 100 kPa are measured at meteorological stations M_0 and M_3 and a pressure of 70 kPa at station M_2 . The temperature of the air at M_0 is 20°C .

As the air is ascending, cloud formation sets in at 84.5 kPa.

Consider a quantity of moist air ascending the mountain with a mass of 2000 kg over each square meter. This moist air reaches the mountain ridge (station M_2) after 1500 seconds. During that rise an amount of 2.45 g of water per kilogram of air is precipitated as rain.

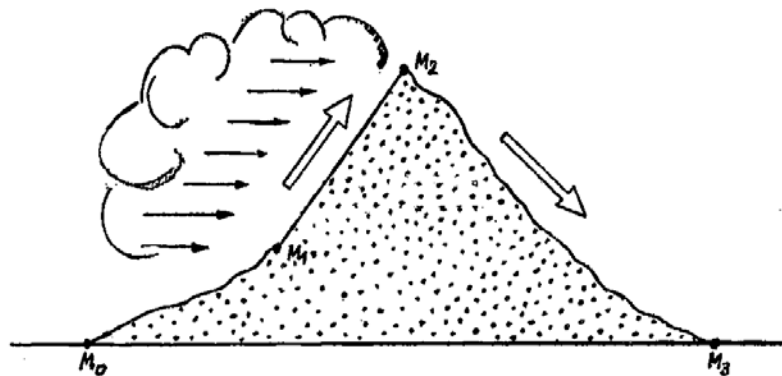

1. Determine temperature T_1 at M_1 where the cloud ceiling forms.
2. What is the height h_1 (at M_1) above station M_0 of the cloud ceiling assuming a linear decrease of atmospheric density?
3. What temperature T_2 is measured at the ridge of the mountain range?
4. Determine the height of the water column (precipitation level) precipitated by the air stream in 3 hours, assuming a homogeneous rainfall between points M_1 and M_2 .

5. What temperature T_3 is measured in the back of the mountain range at station M_3 ?

Discuss the state of the atmosphere at station M_3 in comparison with that at station M_0 .

Hints and Data

The atmosphere is to be dealt with as an ideal gas. Influences of the water vapour on the specific heat capacity and the atmospheric density are to be neglected; the same applies to the temperature dependence of the specific latent heat of vaporisation. The temperatures are to be determined to an accuracy of 1 K, the height of the cloud ceiling to an accuracy of 10 m and the precipitation level to an accuracy of 1 mm.

Specific heat capacity of the atmosphere in the pertaining temperature range:

$$c_p = 1005 \text{ J} \cdot \text{kg}^{-1} \cdot \text{K}^{-1}$$

Atmospheric density for p_0 and T_0 at station M_0 : $\rho_0 = 1.189 \text{ kg} \cdot \text{m}^{-3}$

Specific latent heat of vaporisation of the water within the volume of the cloud:

$$L_v = 2500 \text{ kJ} \cdot \text{kg}^{-1}$$

$$\frac{c_p}{c_v} = \chi = 1.4 \quad \text{and} \quad g = 9.81 \text{ m} \cdot \text{s}^{-2}$$

Solution of problem 1:

1. Temperature T_1 where the cloud ceiling forms

$$T_1 = T_0 \cdot \left(\frac{p_1}{p_0} \right)^{\frac{1-\chi}{\chi}} = 279 \text{ K} \quad (1)$$

2. Height h_1 of the cloud ceiling:

$$p_0 - p_1 = \frac{\rho_0 + \rho_1}{2} \cdot g \cdot h_1, \quad \text{with} \quad \rho_1 = \rho_0 \cdot \frac{p_1}{p_0} \cdot \frac{T_0}{T_1}.$$

$$h_1 = 1410 \text{ m} \quad (2)$$

3. Temperature T_2 at the ridge of the mountain.

The temperature difference when the air is ascending from the cloud ceiling to the mountain ridge is caused by two processes:

- adiabatic cooling to temperature T_x ,

– heating by ΔT by condensation.

$$T_2 = T_x + \Delta T \quad (3)$$

$$T_x = T_1 \cdot \left(\frac{p_2}{p_1} \right)^{\frac{1-\gamma}{\gamma}} = 265 \text{ K} \quad (4)$$

For each kg of air the heat produced by condensation is $L_v \cdot 2.45 \text{ g} = 6.125 \text{ kJ}$.

$$\Delta T = \frac{6.125 \text{ kJ}}{c_p \text{ kg}} = 6.1 \text{ K} \quad (5)$$

$$T_2 = 271 \text{ K} \quad (6)$$

4. Height of precipitated water column

$$h = 35 \text{ mm} \quad (7)$$

5. Temperature T_3 behind the mountain

$$T_3 = T_2 \cdot \left(\frac{p_3}{p_2} \right)^{\frac{1-\gamma}{\gamma}} = 300 \text{ K} \quad (8)$$

The air has become warmer and dryer. The temperature gain is caused by condensation of vapour.

Problem 2: Electrons in a magnetic field

A beam of electrons emitted by a point source P enters the magnetic field \vec{B} of a toroidal coil (toroid) in the direction of the lines of force. The angle of the aperture of the beam $2 \cdot \alpha_0$ is assumed to be small ($2 \cdot \alpha_0 \ll 1$). The injection of the electrons occurs on the mean radius R of the toroid with acceleration voltage V_0 .

Neglect any interaction between the electrons. The magnitude of \vec{B} , B, is assumed to be constant.

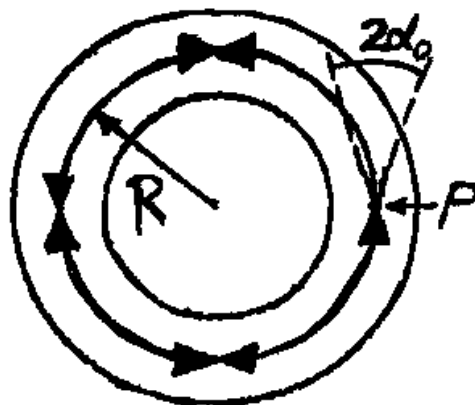

1. To guide the electron in the toroidal field a homogeneous magnetic deflection field \vec{B}_1 is required. Calculate \vec{B}_1 for an electron moving on a circular orbit of radius R in the torus.

2. Determine the value of \vec{B} which gives four focussing points separated by $\pi/2$ as indicated in the diagram.

Note: When considering the electron paths you may disregard the curvature of the magnetic field.

3. The electron beam cannot stay in the toroid without a deflection field \vec{B}_1 , but will leave it with a systematic motion (drift) perpendicular to the plane of the toroid.

a) Show that the radial deviation of the electrons from the injection radius is finite.

b) Determine the direction of the drift velocity.

Note: The angle of aperture of the electron beam can be neglected. Use the laws of conservation of energy and of angular momentum.

Data:

$$\frac{e}{m} = 1.76 \cdot 10^{11} \text{ C} \cdot \text{kg}^{-1}; \quad V_0 = 3 \text{ kV}; \quad R = 50 \text{ mm}$$

Solution of problem 2:

1. Determination of B:

The vector of the velocity of any electron is divided into components parallel with and perpendicular to the magnetic field \vec{B} :

$$\vec{v} = \vec{v}_{\parallel} + \vec{v}_{\perp} \tag{1}$$

The Lorentz force $\vec{F} = -e \cdot (\vec{v} \times \vec{B})$ influences only the perpendicular component, it acts as a radial force:

$$m \cdot \frac{v_{\perp}^2}{r} = e \cdot v_{\perp} \cdot B \tag{2}$$

Hence the radius of the circular path that has been travelled is

$$r = \frac{m}{e} \cdot \frac{v_{\perp}}{B} \tag{3}$$

and the period of rotation which is independent of v_{\perp} is

$$T = \frac{2 \cdot \pi \cdot r}{v_{\perp}} = \frac{2 \cdot \pi \cdot m}{B \cdot e} \quad (4)$$

The parallel component of the velocity does not vary. Because of $\alpha_0 \ll 1$ it is approximately equal for all electrons:

$$v_{\parallel 0} = v_0 \cdot \cos \alpha_0 \approx v_0 \quad (5)$$

Hence the distance b between the focusing points, using eq. (5), is

$$b = v_{\parallel 0} \cdot T \approx v_0 \cdot T \quad (6)$$

From the law of conservation of energy follows the relation between the acceleration voltage V_0 and the velocity v_0 :

$$\frac{m}{2} \cdot v_0^2 = e \cdot V_0 \quad (7)$$

Using eq. (7) and eq. (4) one obtains from eq. (6)

$$b = \frac{2 \cdot \pi}{B} \cdot \sqrt{2 \cdot \frac{m}{e} \cdot V_0} \quad (8)$$

and because of $b = \frac{2 \cdot \pi \cdot R}{4}$ one obtains

$$B = \frac{4}{R} \cdot \sqrt{2 \cdot \frac{m}{e} \cdot V_0} = 1.48 \cdot 10^{-2} \frac{Vs}{m^2} \quad (9)$$

2. Determination of B_1 :

Analogous to eq. (2)

$$m \cdot \frac{v_0^2}{R} = e \cdot v_0 \cdot B_1 \quad (10)$$

must hold.

From eq. (7) follows

$$B_1 = \frac{1}{R} \cdot \sqrt{2 \cdot \frac{m}{e} \cdot V_0} = 0.37 \cdot 10^{-2} \frac{Vs}{m^2} \quad (11)$$

3. Finiteness of r_1 and direction of the drift velocity

In the magnetic field the lines of force are circles with their centres on the symmetry axis (z-axis) of the toroid.

In accordance with the symmetry of the problem, polar coordinates r and φ are introduced into the plane perpendicular to the z-axis (see figure below) and the occurring vector quantities (velocity, magnetic field \vec{B} , Lorentz force) are divided into the corresponding components.

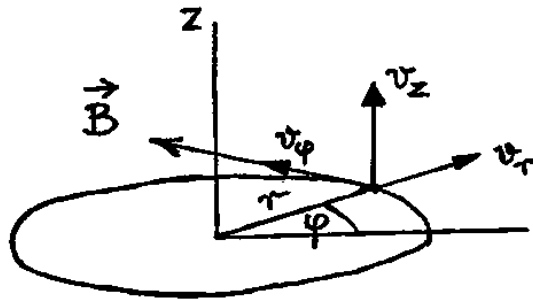

Since the angle of aperture of the beam can be neglected examine a single electron injected tangentially into the toroid with velocity v_0 on radius R .

In a static magnetic field the kinetic energy is conserved, thus

$$E = \frac{m}{2} (v_r^2 + v_\varphi^2 + v_z^2) = \frac{m}{2} v_0^2 \quad (12)$$

The radial points of inversion of the electron are defined by the condition

$$v_r = 0$$

Using eq. (12) one obtains

$$v_0^2 = v_\varphi^2 + v_z^2 \quad (13)$$

Such an inversion point is obviously given by

$$r = R \cdot (v_\varphi = v_0, v_r = 0, v_z = 0).$$

To find further inversion points and thus the maximum radial deviation of the electron the components of velocity v_φ and v_z in eq. (13) have to be expressed by the radius.

v_φ will be determined by the law of conservation of angular momentum. The Lorentz force obviously has no component in the φ - direction (parallel to the magnetic field).

Therefore it cannot produce a torque around the z-axis. From this follows that the

z-component of the angular momentum is a constant, i.e. $L_z = m \cdot v_\phi \cdot r = m \cdot v_0 \cdot R$ and

$$\text{therefore } v_\phi = v_0 \cdot \frac{R}{r} \quad (14)$$

v_z will be determined from the equation of motion in the z-direction. The z-component of the Lorentz force is $F_z = -e \cdot B \cdot v_r$. Thus the acceleration in the z-direction is

$$a_z = -\frac{e}{m} \cdot B \cdot v_r. \quad (15).$$

That means, since B is assumed to be constant, a change of v_z is related to a change of r as follows:

$$\Delta v_z = -\frac{e}{m} \cdot B \cdot \Delta r$$

Because of $\Delta r = r - R$ and $\Delta v_z = v_z$ one finds

$$v_z = -\frac{e}{m} \cdot B \cdot (r - R) \quad (16)$$

Using eq. (14) and eq. (15) one obtains for eq. (13)

$$1 = \left(\frac{R}{r}\right)^2 + A^2 \cdot \left(\frac{r}{R} - 1\right)^2 \quad (17)$$

where $A = \frac{e}{m} \cdot B \cdot \frac{R}{v_0}$

Discussion of the curve of the right side of eq. (17) gives the qualitative result shown in the following diagram:



Hence r_1 is finite. Since $R \leq r \leq r_1$ eq. (16) yields $v_z < 0$. Hence the drift is in the direction of the negative z-axis.

Problem 3: Infinite LC-grid

When sine waves propagate in an infinite LC-grid (see the figure below) the phase of the ac-voltage across two successive capacitors differs by Φ .

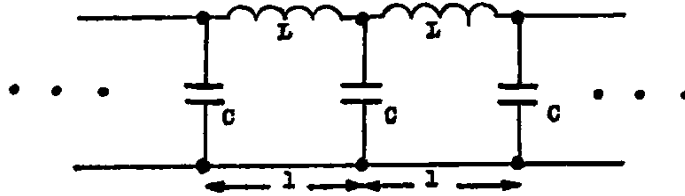

- Determine how Φ depends on ω , L and C (ω is the angular frequency of the sine wave).
- Determine the velocity of propagation of the waves if the length of each unit is ℓ .
- State under what conditions the propagation velocity of the waves is almost independent of ω . Determine the velocity in this case.
- Suggest a simple mechanical model which is an analogue to the above circuit and derive equations which establish the validity of your model.

Formulae:

$$\cos \alpha - \cos \beta = -2 \cdot \sin\left(\frac{\alpha + \beta}{2}\right) \cdot \sin\left(\frac{\alpha - \beta}{2}\right)$$

$$\sin \alpha - \sin \beta = 2 \cdot \cos\left(\frac{\alpha + \beta}{2}\right) \cdot \sin\left(\frac{\alpha - \beta}{2}\right)$$

Solution of problem 3:

a)

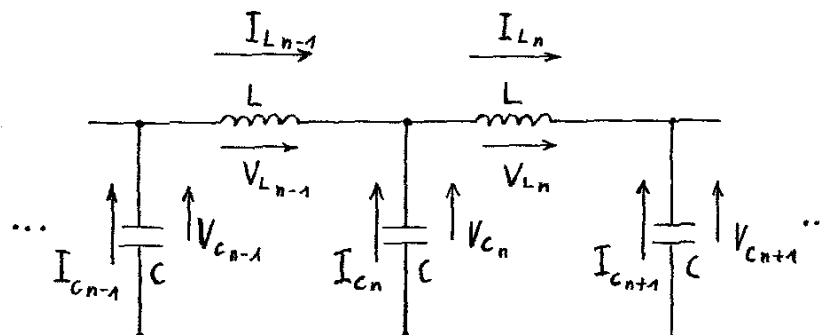

Current law: $I_{L_{n-1}} + I_{C_n} - I_{L_n} = 0$ (1)

Voltage law: $V_{C_{n-1}} + V_{L_{n-1}} - V_{C_n} = 0$ (2)

$$\text{Capacitive voltage drop: } V_{C_{n-1}} = \frac{1}{\omega \cdot C} \cdot \tilde{I}_{C_{n-1}} \quad (3)$$

Note: In eq. (3) $\tilde{I}_{C_{n-1}}$ is used instead of $I_{C_{n-1}}$ because the current leads the voltage by 90° .

$$\text{Inductive voltage drop: } V_{L_{n-1}} = \omega \cdot L \cdot \tilde{I}_{L_{n-1}} \quad (4)$$

Note: In eq. (4) $\tilde{I}_{L_{n-1}}$ is used instead of $I_{L_{n-1}}$ because the current lags behind the voltage by 90° .

$$\text{The voltage } V_{C_n} \text{ is given by: } V_{C_n} = V_0 \cdot \sin(\omega \cdot t + n \cdot \varphi) \quad (5)$$

Formula (5) follows from the problem.

$$\text{From eq. (3) and eq. (5): } I_{C_n} = \omega \cdot C \cdot V_0 \cdot \cos(\omega \cdot t + n \cdot \varphi) \quad (6)$$

From eq. (4) and eq. (2) and with eq. (5)

$$I_{L_{n-1}} = \frac{V_0}{\omega \cdot L} \cdot \left[2 \cdot \sin\left(\omega \cdot t + \left(n - \frac{1}{2}\right) \cdot \varphi\right) \cdot \sin\frac{\varphi}{2} \right] \quad (7)$$

$$I_{L_n} = \frac{V_0}{\omega \cdot L} \cdot \left[2 \cdot \sin\left(\omega \cdot t + \left(n + \frac{1}{2}\right) \cdot \varphi\right) \cdot \sin\frac{\varphi}{2} \right] \quad (8)$$

Eqs. (6), (7) and (8) must satisfy the current law. This gives the dependence of φ on ω , L and C .

$$0 = V_0 \cdot \omega \cdot C \cdot \cos(\omega \cdot t + n \cdot \varphi) + 2 \cdot \frac{V_0}{\omega \cdot L} \cdot \sin\frac{\varphi}{2} \cdot \left[2 \cdot \cos(\omega \cdot t + n \cdot \varphi) \cdot \sin\left(-\frac{\varphi}{2}\right) \right]$$

This condition must be true for any instant of time. Therefore it is possible to divide by $V_0 \cdot \cos(\omega \cdot t + n \cdot \varphi)$.

Hence $\omega^2 \cdot L \cdot C = 4 \cdot \sin^2\left(\frac{\varphi}{2}\right)$. The result is

$$\varphi = 2 \cdot \arcsin\left(\frac{\omega \cdot \sqrt{L \cdot C}}{2}\right) \quad \text{with } 0 \leq \omega \leq \frac{2}{\sqrt{L \cdot C}} \quad (9)$$

b) The distance ℓ is covered in the time Δt thus the propagation velocity is

$$v = \frac{\ell}{\Delta t} = \frac{\omega \cdot \ell}{\varphi} \quad \text{or} \quad v = \frac{\omega \cdot \ell}{2 \cdot \arcsin\left(\frac{\omega \cdot \sqrt{L \cdot C}}{2}\right)} \quad (10)$$

c)

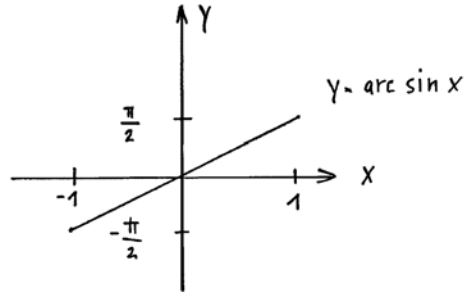

Slightly dependent means $\arcsin\left(\frac{\omega \cdot \sqrt{L \cdot C}}{2}\right) \sim \omega$, since v is constant in that case.

This is true only for small values of ω . That means $\frac{\omega \cdot \sqrt{L \cdot C}}{2} \ll 1$ and therefore

$$v_0 = \frac{\ell}{\sqrt{L \cdot C}} \quad (11)$$

d) The energy is conserved since only inductances and capacitances are involved. Using the terms of a) one obtains the capacitive energy

$$W_C = \sum_n \frac{1}{2} \cdot C \cdot V_{C_n}^2 \quad (12)$$

and the inductive energy

$$W_L = \sum_n \frac{1}{2} \cdot L \cdot I_{L_n}^2 \quad (13)$$

From this follows the standard form of the law of conservation of energy

$$W_C = \sum_n \frac{1}{2} (C \cdot V_{C_n}^2 + L \cdot I_{L_n}^2) \quad (14)$$

The relation to mechanics is not recognizable in this way since two different physical quantities (V_{C_n} and I_{L_n}) are involved and there is nothing that corresponds to the relation between the locus x and the velocity $v = \dot{x}$.

To produce an analogy to mechanics the energy has to be described in terms of the charge Q , the current $I = \dot{Q}$ and the constants L and C . For this purpose the voltage V_{C_n} has to be expressed in terms of the charges Q_{L_n} passing through the coil.

One obtains:

$$W = \sum_n \left[\underbrace{\frac{L}{2} \cdot \dot{Q}_{L_n}^2}_A + \underbrace{\frac{1}{2 \cdot C} (Q_{L_n} - Q_{L_{n-1}})^2}_B \right] \quad (15)$$

Mechanical analogue:

A (kinetic part): $\dot{Q}_{L_n} \longrightarrow v_n; \quad L \longrightarrow m$

B (potential part): $Q_{L_n} \longrightarrow x_n$

x_n : displacement and v_n : velocity.

However, Q_{L_n} could equally be another quantity (e.g. an angle). L could be e.g. a moment of inertia.

From the structure of the problems follows: Interaction only with the nearest neighbour (the force rises linearly with the distance). A possible model could be:

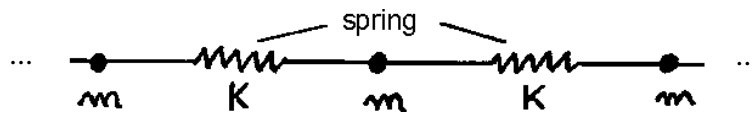

Another model is:

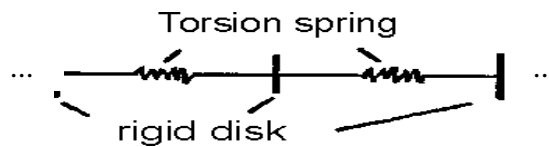

Experimental Problems

Problem 4: Refractive indices

Find the refractive indices of a prism, n_p , and a liquid, n_l . Ignore dispersion.

a) Determine the refractive index n_p of a single prism by two different experimental methods.

Illustrate your solution with accurate diagrams and deduce the relations necessary to calculate the refractive index. (One prism only should be used).

- b) Use two identical prisms to determine the refractive index n_L of a liquid with $n_L < n_p$. Illustrate your solution with accurate diagrams and deduce the relations necessary to calculate the refractive index.

Apparatus:

Two identical prisms with angles of 30° , 60° and 90° ; a set square, a glass dish, a round table, a liquid, sheets of graph paper, other sheets of paper and a pencil.

Formulae: $\sin(\alpha \pm \beta) = \sin \alpha \cdot \cos \beta \pm \cos \alpha \cdot \sin \beta$

Additional remarks: You may mark the opaque sides of the prisms with a pencil. The use of the lamp is optional.

Solution of problem 4:

- a) Calculation of the refractive index of the prism

First method:

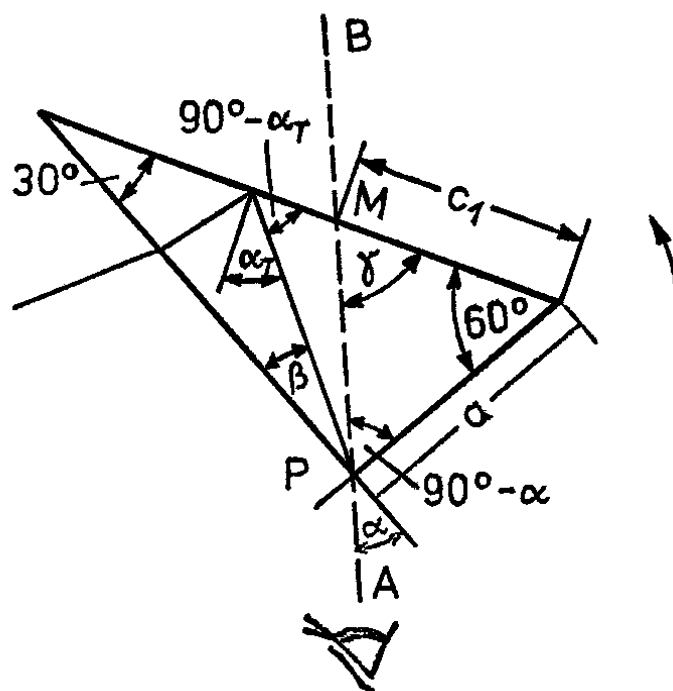

Draw a straight line A – B on a sheet of paper and let this be your line of sight. Place the prism with its rectangular edge facing you onto the line (at point P on the line). Now turn the prism in the direction of the arrow until the dark edge of total reflection which can be seen in the short face of the prism coincides with the 90° edge of the prism. Mark a point M and measure the length c_1 . Measure also the length of the short face of the prism.

The following equations apply:

$$\sin \alpha_T = \frac{1}{n_p} \quad (1)$$

$$\frac{\sin \alpha}{\sin \beta} = n_p \quad (2)$$

$$\beta = 60^\circ - \alpha_T \quad (3)$$

$$\gamma = 30^\circ + \alpha \quad (4)$$

$$\frac{\sin \gamma}{\sin(90^\circ - \alpha)} = \frac{a}{c_1} \quad (5)$$

From eq. (5) follows with eq. (4) and the given formulae:

$$\frac{a}{c_1} \cdot \cos \alpha = \sin(30^\circ + \alpha) = \frac{1}{2} \cdot \cos \alpha + \frac{1}{2} \cdot \sqrt{3} \cdot \sin \alpha$$

$$\sin \alpha = \frac{2a - c_1}{2 \cdot \sqrt{a^2 - a \cdot c_1 + c_1^2}} \quad (6)$$

From eqs. (2), (3) and (1) follows:

$$\sin \alpha = n_p \cdot \sin(60^\circ - \alpha_T) = \frac{n_p}{2} \cdot (\sqrt{3} \cdot \cos \alpha_T - \sin \alpha_T)$$

$$n_p = + \left\{ \frac{1}{3} \cdot (2 \cdot \sin \alpha + 1)^2 + 1 \right\}^{1/2} \quad (7)$$

When measuring c_1 and a one notices that within the error limits of ± 1 mm a equals c_1 .

$$\text{Hence: } \sin \alpha = \frac{1}{2} \text{ and } n_p = 1.53. \quad (8)$$

Second method:

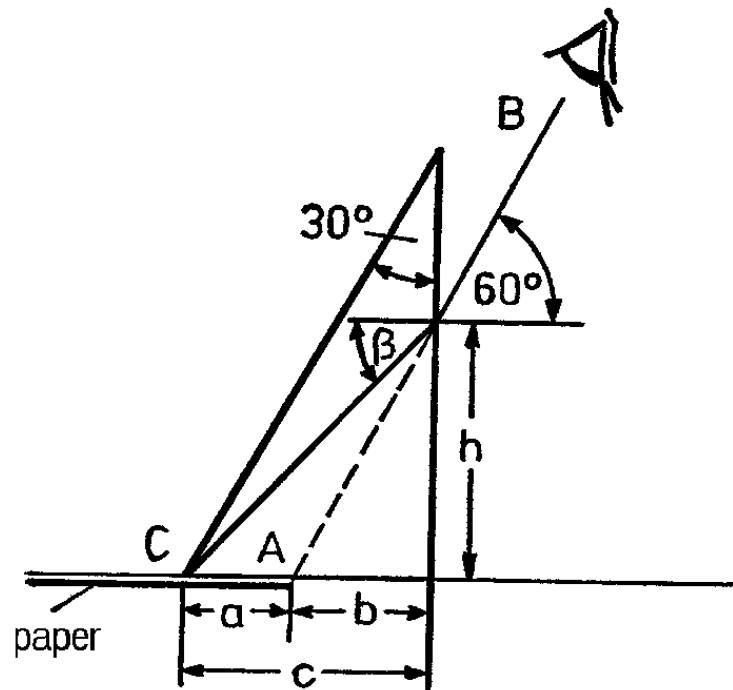

Place edge C of the prism on edge A of a sheet of paper and look along the prism hypotenuse at edge A so that your direction of sight B-A and the table surface form an angle of 60° . Then shift the prism over the edge of the paper into the position shown, such that prism edge C can be seen inside the prism collinear with edge A of the paper outside the prism. The direction of sight must not be changed while the prism is being displaced.

The following equations apply:

$$\left. \begin{array}{l} \tan \beta = \frac{h}{c} \\ \tan 60^\circ = \sqrt{3} = \frac{h}{b} \end{array} \right\} \Rightarrow h = b \cdot \sqrt{3} = \frac{c \cdot \sin \beta}{\sqrt{1 - \sin^2 \beta}} \quad (9)$$

$$\sin \beta = \sin 60^\circ \cdot \frac{1}{n_p} = \frac{\sqrt{3}}{2 \cdot n_p} \quad (10)$$

$$n_p = \frac{1}{2} \cdot \sqrt{\left(\frac{c}{b}\right)^2 + 3} \quad (11)$$

With the measured values $c = 29 \text{ mm}$ and $b = 11.5 \text{ mm}$, it follows

$$n_p = 1.53. \quad (12)$$

b) Determination of the refractive index of the liquid by means of two prisms

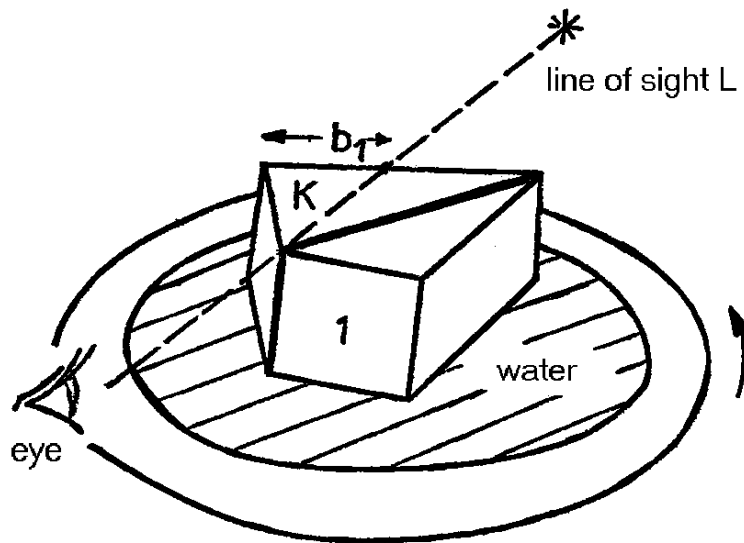

Place the two prisms into a glass dish filled with water as shown in the figure above. Some water will rise between the hypotenuse surfaces. By pressing and moving the prisms slightly against each other the water can be made to cover the whole surface. Look over the 60° edges of the prisms along a line of sight L (e.g. in the direction of a fixed point on an illuminated wall). Turn the glass dish together with the two prisms in such a way that the dark shadow of total reflection which can be seen in the short face of prism 1 coincides with the 60° edge of that prism (position shown in the figure below).

While turning the arrangement take care to keep the 60° edge (point K) on the line of sight L. In that position measure the length b_1 with a ruler (marking, reading). The figure below illustrates the position described.

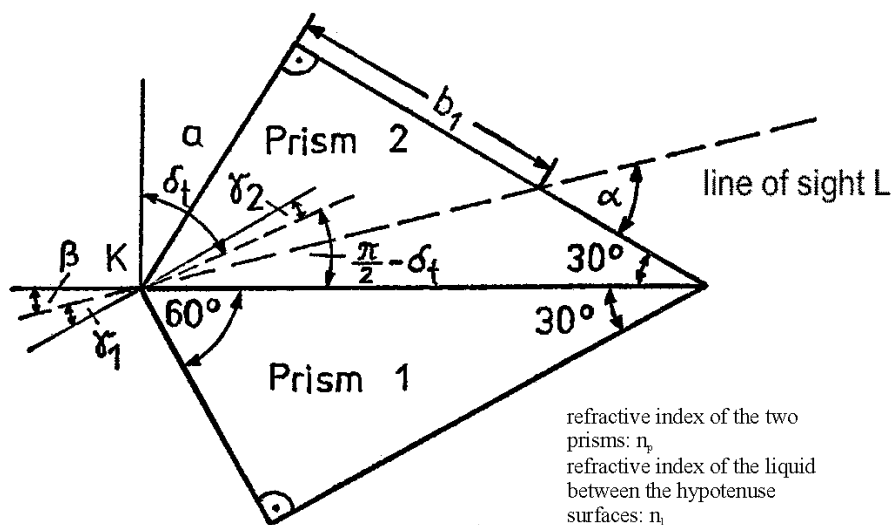

If the refractive index of the prism is known (see part a) the refractive index of the liquid may be calculated as follows:

$$\sin \alpha = \frac{a}{\sqrt{a^2 + b_1^2}} \quad (13)$$

$$\beta = \alpha - 30^\circ; \quad \gamma_1 = 30^\circ - \beta = 60^\circ - \alpha \quad (14, 15)$$

$$\frac{\sin \gamma_1}{\sin \gamma_2} = n_p \quad \text{refraction at the short face of prism 1.} \quad (16)$$

The angle of total reflection δ_t at the hypotenuse surface of prism 1 in the position described is:

$$\frac{\pi}{2} - \delta_t = 30^\circ - \gamma_2 \quad (17)$$

$$\delta_t = 60^\circ + \arcsin\left(\frac{\sin \gamma_1}{n_p}\right) \quad (18)$$

From this we can easily obtain n_1 :

$$n_1 = n_p \cdot \sin \delta_t = n_p \cdot \sin \left\{ 60^\circ + \arcsin \frac{\sin \gamma_1}{n_p} \right\} \quad (19)$$

Numerical example for water as liquid:

$b_1 = 1.9 \text{ cm}$; $\alpha = 55.84^\circ$; $\gamma_1 = 4.16^\circ$; $\delta_t = 62.77^\circ$; $a = 2.8 \text{ cm}$; with $n_p = 1.5$ follows

$$n_1 = 1.33. \quad (20)$$

Grading Scheme

Theoretical problems

Problem 1: Ascending moist air	
part 1	2
part 2	2
part 3	2
part 4	2
part 5	2
	10

Problem 2: Electron in a magnetic field	
part 1	3
part 2	1
part 3	6
	10

Problem 3: Infinite LC-grid	
part a	4
part b	1
part c	1
part d	4
	10

Problem 4: Refractive indices	
part a, first method	5
part a, second method	5
part b	10
	20

19th International Physics Olympiad - 1988

Bad Ischl / Austria

THEORY 1

Spectroscopy of Particle Velocities

Basic Data

The absorption and emission of a photon is a reversible process. A good example is to be found in the excitation of an atom from the ground state to a higher energy state and the atoms' subsequent return to the ground state. In such a case we may detect the absorption of a photon from the phenomenon of spontaneous emission or fluorescence. Some of the more modern instrumentation make use of this principle to identify atoms, and also to measure or calculate the value of the velocity in the velocity spectrum of the electron beam.

In an idealised experiment (see fig. 19.1) a single-charged ion travels in the opposite direction to light from a laser source with velocity v . The wavelength of light from the laser source is adjustable. An ion with velocity Zero can be excited to a higher energy state by the application of laser light having a wavelength of $\lambda = 600$ nm. If we excite a moving ion, our knowledge on Dopplers' effect tells us that we need to apply laser light of a wavelength other than the value given above.

There is given a velocity spectrum embracing velocity magnitude from $v_1 = 0 \frac{\text{m}}{\text{s}}$ to $v_2 = 6,000 \frac{\text{m}}{\text{s}}$. (see fig. 19.1)

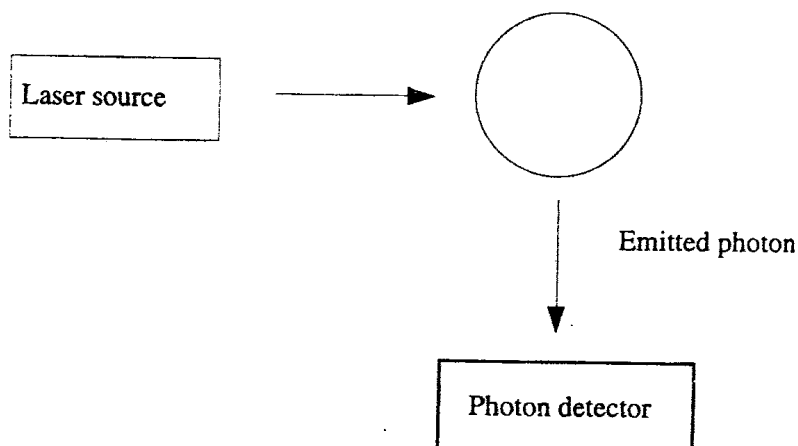

Fig. 19.1

Questions

1.1

1.1.1

What range of wavelength of the laser beam must be used to excite ions of all velocities in the velocity spectrum given above ?

1.1.2

A rigorous analysis of the problem calls for application of the principle from the theory of special relativity

$$v' = v \cdot \sqrt{\frac{1 + \frac{v}{c}}{1 - \frac{v}{c}}}$$

Determine the error when the classical formula for Dopplers' effect is used to solve the problem.

1.2

Assuming the ions are accelerated by a potential U before excited by the laser beam, determine the relationship between the width of the velocity spectrum of the ion beam and the accelerating potential. Does the accelerating voltage increase or decrease the velocity spectrum width ?

1.3

Each ion has the value $\frac{e}{m} = 4 \cdot 10^6 \frac{\text{A} \cdot \text{s}}{\text{kg}}$, two energy levels corresponding to wavelength $\lambda^{(1)} = 600 \text{ nm}$ and wavelength $\lambda^{(2)} = \lambda^{(1)} + 10^{-3} \text{ nm}$. Show that lights of the two wavelengths used to excite ions overlap when no accelerating potential is applied. Can accelerating voltage be used to separate the two spectra of laser light used to excite ions so that they no longer overlap ? If the answer is positive, calculate the minimum value of the voltage required.

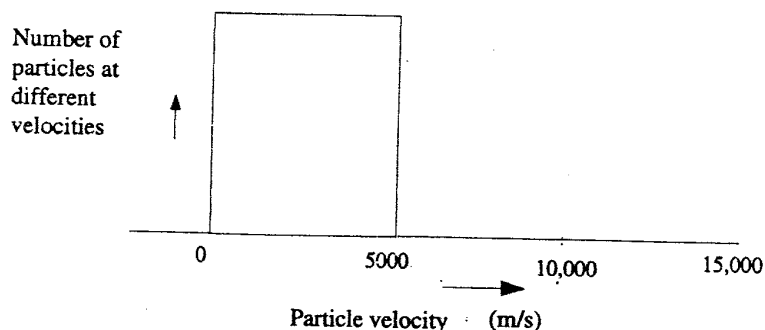

Fig. 19.2

Solution

1.1

1.1.1

Let v be the velocity of the ion towards the laser source relative to the laser source, ν' the frequency of the laser light as observed by the observer moving with the ion (e.g. in the frame in which the velocity of the ion is 0) and ν the frequency of the laser light as observed by the observer at rest with respect to the laser source.

Classical formula for Doppler's effect is given as

$$\nu' = \nu \cdot \left(1 + \frac{v}{c}\right) \dots\dots\dots (1)$$

Let ν^* be the frequency absorbed by an ion (characteristic of individual ions) and ν_L be the frequency of the laser light used to excite an ion at rest, hence:

$$\nu^* = \nu_L$$

For a moving ion, the frequency used to excite ions must be lower than ν^* .

Let ν_H be the frequency used to excite the moving ion.

When no accelerating voltage is applied

frequency of laser light used to excite ions	magnitude of velocity of ions	frequency of laser light absorbed by ions	wavelength of laser light used to excite ions
ν_H	0	ν^*	λ_1
ν_L	$v = 6 \cdot 10^3 \text{ m/s}$	ν^*	λ_2

$$\nu_L < \nu_H$$

$$\nu_L = \nu^*$$

Calculation of frequency ν_H absorbed by moving ions.

$$\nu^* = \nu_L \cdot \left(1 + \frac{v}{c}\right) \quad \text{where } \nu^* = \nu_H = 5 \cdot 10^{14} \text{ Hz and } v = 6 \cdot 10^3 \text{ m/s} \dots\dots\dots (2)$$

The difference in the values of the frequency absorbed by the stationary ion and the ion moving with the velocity v $\Delta\nu = \nu_H - \nu_L$

The difference in the values of the wavelengths absorbed by the stationary ion and the ion moving with the velocity v $\Delta\lambda = \lambda_L - \lambda_H$

(higher frequency implies shorter wavelength)

$$\lambda_L - \lambda_H = \frac{c}{v_L} - \frac{c}{v_H}$$

from (2)

$$\lambda_L - \lambda_H = \frac{c}{v^*} \cdot \left(1 + \frac{v}{c}\right) - \frac{c}{v^*} = \frac{v}{v^*}$$

In this case

$$\lambda_L - \lambda_H = \frac{6 \cdot 10^3}{5 \cdot 10^{14}} \text{ m} = 12 \cdot 10^{-3} \text{ nm}$$

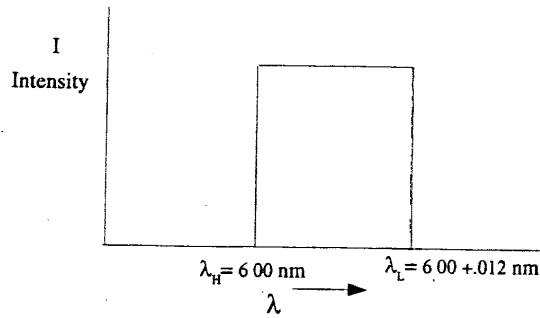

Fig. 19.3' Spectrum of laser light used to excite ions

1.1.2

The formula for calculation of ν' as observed by the observer moving towards light source based on the principle of the theory of special relativity,

$$\nu' = \nu \cdot \sqrt{\frac{1 + \frac{v}{c}}{1 - \frac{v}{c}}}$$

where ν is the magnitude of the velocity of the observer towards the light source, ν' is the frequency absorbed by the ion moving with the velocity v towards the light source (also observed by the observer moving with velocity v towards the laser source) and ν is the frequency of laser light as observed by an observer at rest.

(To put in a metaphoric way, the moving ion “sees” the laser light of frequency ν' even though the scientist who operates the laser source insists that he is sending a laser beam of frequency ν).

$$\nu' = \nu \cdot \sqrt{\left(1 + \frac{v}{c}\right) \cdot \left(1 + \frac{v}{c} + \frac{v^2}{c^2} + \dots\right)} = \nu \cdot \sqrt{\left(1 + \frac{v}{c}\right)^2 + \left(1 + \frac{v}{c}\right) \cdot \frac{v^2}{c^2} + \dots}$$

$$\nu' = \nu \cdot \left(1 + \frac{v}{c}\right) \cdot \left[1 + \frac{v^2}{c^2} \cdot \frac{1}{1 + \frac{v}{c}} + \dots\right]^{\frac{1}{2}} = \nu \cdot \left(1 + \frac{v}{c}\right) \cdot \left[1 + \frac{v^2}{2 \cdot c^2} \cdot \frac{1}{\left(1 + \frac{v}{c}\right)} + \dots\right]$$

The second term in the brackets represents the error if the classical formula for Doppler's effect is employed.

$$\frac{v}{c} = 2 \cdot 10^{-5}$$

$$\frac{v^2}{2 \cdot c^2} \cdot \frac{1}{\left(1 + \frac{v}{c}\right)} = \frac{1}{2} \cdot \frac{4 \cdot 10^{-10}}{1 + 2 \cdot 10^{-5}} \approx 2 \cdot 10^{-10}$$

The error in the application of classical formula for Doppler's effect however is of the order of the factor $2 \cdot 10^{-10}$. This means that classical formula for Doppler's effect can be used to analyze the problem without losing accuracy.

1.2 When acceleration voltage is used

frequency of laser light used to excite ions	magnitude of velocity of ions	frequency of laser light absorbed by ions	wavelength of laser light used to excite ions
ν_H'	ν_H'	$\nu^* = 5 \cdot 10^{14} \text{ Hz}$	λ_H'
ν_L'	ν_L'	$\nu^* = 5 \cdot 10^{14} \text{ Hz}$	λ_L'

Lowest limit of the kinetic energy of ions $\frac{1}{2} \cdot m \cdot (\nu_L')^2 = e \cdot U$ and $\nu_L' = \sqrt{\frac{2 \cdot e \cdot U}{m}}$

Highest limit of the kinetic energy of ions $\frac{1}{2} \cdot m \cdot (\nu_H')^2 = \frac{1}{2} \cdot m \cdot v^2 + e \cdot U$

and $\nu_H' = \sqrt{v^2 + \frac{2 \cdot e \cdot U}{m}}$

Spectrum width of velocity spectrum $\boxed{\nu_H' - \nu_L' = \sqrt{v^2 + \frac{2 \cdot e \cdot U}{m}} - \sqrt{\frac{2 \cdot e \cdot U}{m}}}$ (3)

(Note that the final velocity of accelerated ions is not the sum of v and $\sqrt{\frac{2 \cdot e \cdot U}{m}}$ as velocity changes with time).

In equation (3) if $\sqrt{\frac{2 \cdot e \cdot U}{m}}$ is negligibly small, the change in the width of the spectrum is negligible, by the same token of argument if $\sqrt{\frac{2 \cdot e \cdot U}{m}}$ is large or approaches ∞ , the width of the spectrum of the light used in exciting the ions becomes increasingly narrow and approaches 0.

1.3

Given two energy levels of the ion, corresponding to wavelength $\lambda^{(1)} = 600 \text{ nm}$ and $\lambda^{(2)} = 600 + 10^{-2} \text{ nm}$

For the sake of simplicity, the following sign notations will be adopted:

The superscript in the bracket indicates energy level (1) or (2) as the case may be. The sign $'$ above denotes the case when accelerating voltage is applied, and also the subscripts H and L apply to absorbed frequencies (and also wavelengths) correspond to the high velocity and low velocity ends of the velocity spectrum of the ion beam respectively.

The subscript following λ (or ν) can be either 1 or 2, with number 1 corresponding to lowest velocity of the ion and number 2 the highest velocity of the ion. When no accelerating voltage is applied, the subscript 1 implies that minimum velocity of the ion is 0, and the highest velocity of the ion is 6000 m/s. If accelerating voltage U is applied, number 1 indicates that the wavelength of laser light pertains to the ion of lowest velocity and number 2 indicates the ion of the highest velocity.

Finally the sign $*$ indicates the value of the wavelength (λ^*) or frequency (ν^*) absorbed by the ion (characteristic absorbed frequency).

When no accelerating voltage is applied:

For the first energy level:

frequency of laser light used to excite ions	magnitude of velocity of ions	frequency of laser light absorbed by ions	wavelength of laser light used to excite ions
$\nu_H^{(1)}$	0	$\nu^{(1)*} = 5 \cdot 10^{14} \text{ Hz}$	$\lambda_1^{(1)}$
$\nu_L^{(1)}$	$v = 6 \cdot 10^3 \text{ m/s}$	$\nu^{(1)*} = 5 \cdot 10^{14} \text{ Hz}$	$\lambda_2^{(1)}$

$$\nu_H^{(1)*} = \nu_L^{(1)*} = \nu^{(1)*} = 5 \cdot 10^{14} \text{ Hz}$$

$$\text{Differences in frequencies of laser light used to excite ions} = \nu_H^{(1)} - \nu_L^{(1)}$$

$$\text{Differences of wavelengths of laser light used to excite ions} = \lambda_L^{(1)} - \lambda_H^{(1)}$$

$$\frac{v}{\nu_L^{(1)*}} = \frac{6000}{5 \cdot 10^{14}} = 0,012 \text{ nm}$$

For the second energy level:

frequency of laser light used to excite ions	magnitude of velocity of ions	frequency of laser light absorbed by ions	wavelength of laser light used to excite ions
$\nu_H^{(2)}$	0	$\nu^{(2)*} = 5 \cdot 10^{14} \text{ Hz}$	$\lambda_H^{(2)}$
$\nu_L^{(2)}$	$v = 6000 \text{ m/s}$	$\nu^{(2)*} = 5 \cdot 10^{14} \text{ Hz}$	$\lambda_L^{(2)}$

$$\nu_H^{(2)*} = \nu_L^{(2)*} = \nu^{(2)*} = 5 \cdot 10^{14} \text{ Hz}$$

$$\text{Differences in frequencies of laser light used to excite ions} = \nu_H^{(2)} - \nu_L^{(2)}$$

$$\text{Differences in wavelengths of laser light used to excite ions} = \lambda_L^{(2)} - \lambda_H^{(2)}$$

This gives
$$\frac{6000}{5 \cdot 10^{14}} = 0,012 \text{ nm}$$

Hence the spectra of laser light (absorption spectrum) used to excite an ion at two energy levels overlap as shown in fig. 19.4.

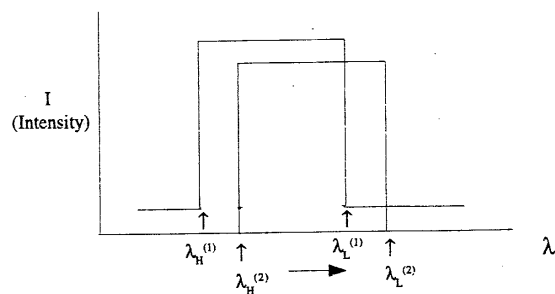

Fig. 19.4 Spectrum of laser light used to excite ions when no accelerating voltage is applied (Absorption Spectrum)

When accelerating voltage is applied:

Let $\lambda_H^{(1)'}$ and $\lambda_L^{(1)'}$ be the range of the wavelengths used to excite ions in the first energy level, when accelerating voltage is applied. (Note the prime sign to denote the situation in which the accelerating voltage is used), and let $\lambda_H^{(2)'}$ and $\lambda_L^{(2)'}$ represent the range of the wavelengths used to excite ions in the second energy level also when an accelerating voltage is applied.

Condition for the two spectra not to overlap:

$$\lambda_H^{(2)'} \geq \lambda_L^{(1)'} \quad (\text{see fig. 19.4}) \dots\dots\dots (4)$$

(Keep in mind that lower energy means longer wavelengths and vice versa).

From condition (3): $\lambda_L - \lambda_H = \frac{v}{v^*} \dots\dots\dots (5)$

The meanings of this equation is if the velocity of the ion is v , the wavelength which the ion “sees” is λ_L , when λ_H is the wavelength which the ion of zero-velocity “sees”.

Equation (5) may be rewritten in the context of the applications of accelerating voltage in order for the two spectra of laser light will not overlap as follows:

$$\lambda_L^{(N)'} - \lambda_H^{(N)'} = \frac{v'}{v^*} \quad \text{where N is the order of the energy level} \dots\dots\dots (6)$$

The subscript L relates λ to lowest velocity of the ion which “sees” frequency v^* . The lowest velocity in this case is $\sqrt{\frac{2 \cdot e \cdot U}{m}}$ and the subscript H relates λ to the highest velocity of the ion, in this case $\sqrt{v^2 + \frac{2 \cdot e \cdot U}{m}}$.

Equation (6) will be used to calculate

- width of velocity spectrum of the ion accelerated by voltage U
- potential U which results in condition given by (4)

Let us take up the second energy level (lower energy level of the two ones) of the ion first:

$$\lambda_L^{(2)'} - \lambda_H^{(2)} = \frac{v'}{v^*} \dots\dots\dots (7)$$

substitute

$$v' = \sqrt{\frac{2 \cdot e \cdot U}{m}}$$

$$\lambda_H^{(1)} = 600 + 10^{-3} \text{ nm}$$

$$v^* = 5 \cdot 10^{14} \text{ Hz}$$

$$v = 0 \text{ m/s}$$

$$\lambda_H^{(2)'} = (600 + 0,001) \cdot 10^{-9} + \frac{\sqrt{\frac{2 \cdot e \cdot U}{m}}}{5 \cdot 10^{14}} \text{ m} \dots\dots\dots (8)$$

Considering the first energy level of the ion

$$\lambda_L^{(1)'} - \lambda_H^{(1)} = \frac{v'}{v^*} \dots\dots\dots (9)$$

In this case

$$v' = \sqrt{v^2 + \frac{2 \cdot e \cdot U}{m}}$$

$$v^* = 5 \cdot 10^{14} \text{ Hz}$$

$$v = 6000 \text{ m/s}$$

$$\lambda_H^{(1)} = 600 \cdot 10^{-9} \text{ m}$$

$$\lambda_L^{(1)'} = 600 \cdot 10^{-9} + \frac{\sqrt{v^2 + \frac{2 \cdot e \cdot U}{m}}}{5 \cdot 10^{14}} \text{ m} \dots\dots\dots (10)$$

Substitute $\lambda_H^{(2)'}$ from (8) and $\lambda_L^{(1)'}$ from (10) in (4) one gets

$$(600 + 0,001) \cdot 10^{-9} + \frac{\sqrt{\frac{2 \cdot e \cdot U}{m}}}{5 \cdot 10^{14}} \geq 600 \cdot 10^{-9} + \frac{\sqrt{v^2 + \frac{2 \cdot e \cdot U}{m}}}{5 \cdot 10^{14}}$$

$$500 \geq \frac{\sqrt{v^2 + \frac{2 \cdot e \cdot U}{m}}}{5 \cdot 10^{14}} - \frac{\sqrt{\frac{2 \cdot e \cdot U}{m}}}{5 \cdot 10^{14}}$$

$$500 \geq \sqrt{36 \cdot 10^6 + 2 \cdot 4 \cdot 10^6 \cdot U} - \sqrt{2 \cdot 4 \cdot 10^6 \cdot U}$$

assume that U is of the order of 100 and over,

then
$$\sqrt{8 \cdot 10^6 \cdot U} \cdot \left(1 + \frac{9}{4 \cdot U}\right) - \sqrt{8 \cdot 10^6 \cdot U} \leq 500$$

$$\frac{1}{\sqrt{2 \cdot U}} \cdot 9 \cdot 10^3 \leq 500$$

$$\sqrt{2 \cdot U} \geq 324$$

$$\boxed{U \geq 162 \text{ V}}$$

The minimum value of accelerating voltage to avoid overlapping of absorption spectra is approximately 162 V

THEORY 2

Maxwell's Wheel

Introduction

A cylindrical wheel of uniform density, having the mass $M = 0,40$ kg, the radius $R = 0,060$ m and the thickness $d = 0,010$ m is suspended by means of two light strings of the same length from the ceiling. Each string is wound around the axle of the wheel. Like the strings, the mass of the axle is negligible. When the wheel is turned manually, the strings are wound up until the centre of mass is raised $1,0$ m above the floor. If the wheel is allowed to move downward vertically under the pulling force of the gravity, the strings are unwound to the full length of the strings and the wheel reaches the lowest point. The strings then begin to wound in the opposite sense resulting in the wheel being raised upwards.

Analyze and answer the following questions, assuming that the strings are in vertical position and the points where the strings touch the axle are directly below their respective suspending points (see fig. 19.5).

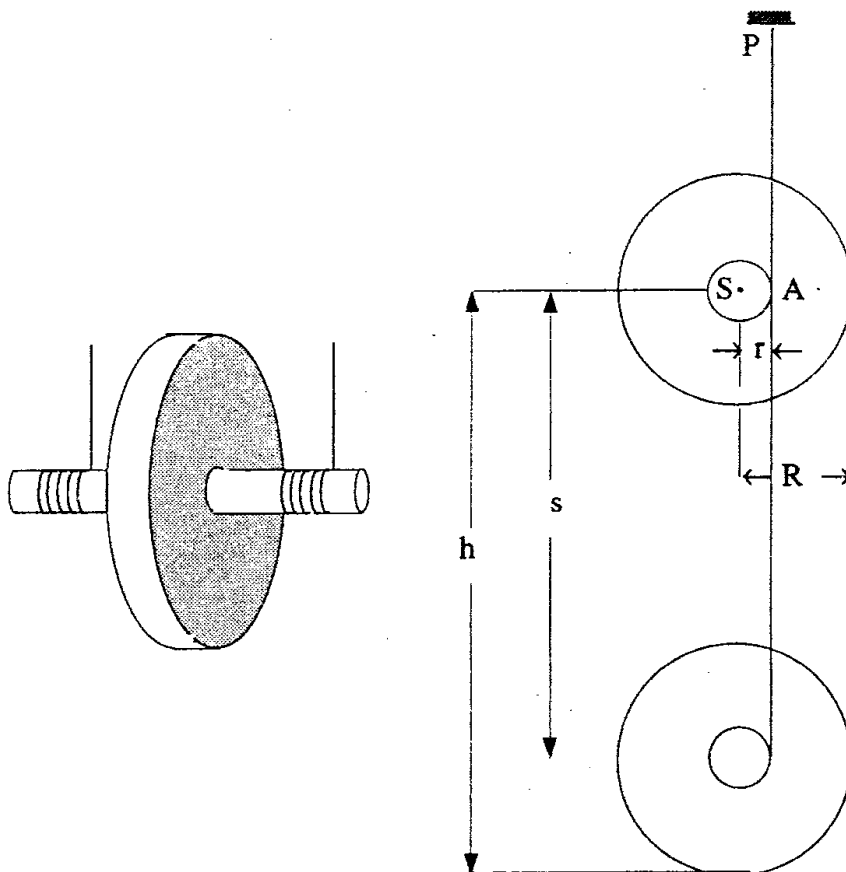

Fig. 19.5

Questions

2.1

Determine the angular speed of the wheel when the centre of mass of the wheel covers the vertical distance s .

2.2

Determine the kinetic energy of the linear motion of the centre of mass E_r after the wheel travels a distance $s = 0,50$ m, and calculate the ratio between E_r and the energy in any other form in this problem up to this point.

Radius of the axle = 0,0030 m

2.3

Determine the tension in the string while the wheel is moving downward.

2.4

Calculate the angular speed ω' as a function of the angle Φ when the strings begin to unwind themselves in opposite sense as depicted in fig. 19.6.

Sketch a graph of variables which describe the motion (in cartesian system which suits the problem) and also the speed of the centre of mass as a function of Φ .

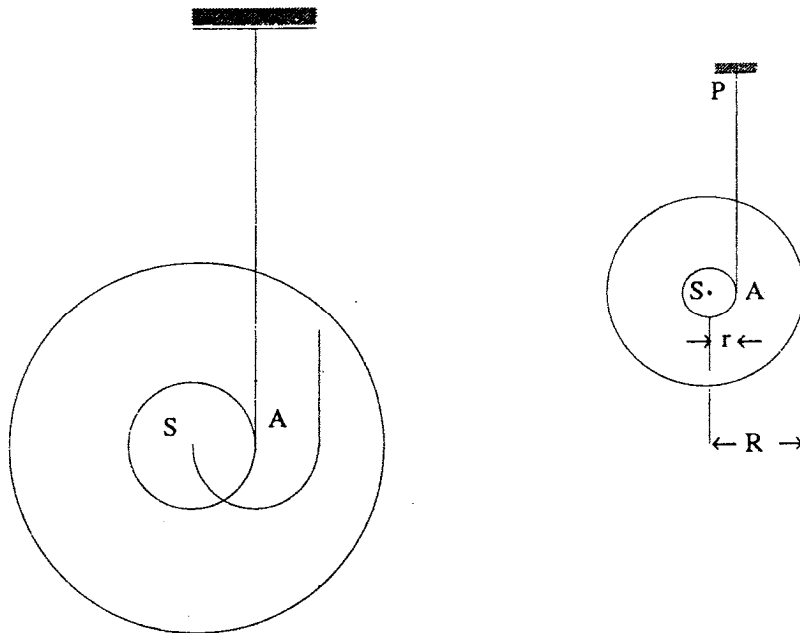

Fig. 19.6

2.5

If the string can withstand a maximum tension $T_m = 10$ N, find the maximum length of the string which may be unwound without breaking by the wheel.

Solution

2.1

conservation of energy: $M \cdot g \cdot s = \frac{1}{2} \cdot I_A \cdot \omega^2$ (1)

where ω is the angular speed of the wheel and I_A is the moment of inertia about the axis through A.

Note: If we would take the moment of inertia about S instead of A we would have

$$M \cdot g \cdot s = \frac{1}{2} \cdot I_S \cdot \omega^2 + \frac{1}{2} \cdot m \cdot v^2$$

where v is the speed of the centre of mass along the vertical.

This equation is the same as the above one in meanings since

$$I_A = I_S + M \cdot r^2 \quad \text{and} \quad I_S = M \cdot R^2$$

From (1) we get
$$\omega = \sqrt{\frac{2 \cdot M \cdot g \cdot s}{I_A}}$$

substitute
$$I_A = \frac{1}{2} \cdot M \cdot r^2 + M \cdot R^2$$

$$\omega = \sqrt{\frac{2 \cdot g \cdot s}{r^2 + \frac{R^2}{2}}}$$

Putting in numbers we get

$$\omega = \sqrt{\frac{2 \cdot 9,81 \cdot 0,50}{9 \cdot 10^{-6} + \frac{1}{2} \cdot 36 \cdot 10^{-4}}} \approx 72,4 \frac{\text{rad}}{\text{s}}$$

2.2

Kinetic energy of linear motion of the centre of mass of the wheel is

$$E_T = \frac{1}{2} \cdot M \cdot v^2 = \frac{1}{2} \cdot M \cdot \omega^2 \cdot r^2 = \frac{1}{2} \cdot 0,40 \cdot 72,4^2 \cdot 9 \cdot 10^{-6} = 9,76 \cdot 10^{-3} \text{ J}$$

Potential energy of the wheel

$$E_P = M \cdot g \cdot s = 0,40 \cdot 9,81 \cdot 0,50 = 1,962 \text{ J}$$

Rotational kinetic energy of the wheel

$$E_R = \frac{1}{2} \cdot I_S \cdot \omega^2 = \frac{1}{2} \cdot 0,40 \cdot 1,81 \cdot 10^{-3} \cdot 72,4^2 = 1,899 \text{ J}$$

$$\frac{E_T}{E_R} = \frac{9,76 \cdot 10^{-3}}{1,899} = 5,13 \cdot 10^{-3}$$

2.3

Let $\frac{T}{2}$ be the tension in each string.

Torque τ which causes the rotation is given by $\tau = M \cdot g \cdot r = I_A \cdot \alpha$

where α is the angular acceleration $\alpha = \frac{M \cdot g \cdot r}{I_A}$

The equation of the motion of the wheel is $M \cdot g - T = M \cdot a$

Substituting $a = \alpha \cdot r$ and $I_A = \frac{1}{2} \cdot M \cdot r^2 + M \cdot R^2$ we get

$$T = M \cdot g + \frac{M \cdot g \cdot r^2}{\frac{1}{2} \cdot M \cdot R^2 + M \cdot r^2} = M \cdot g \cdot \left(1 + \frac{2 \cdot r^2}{R^2 + 2 \cdot r^2} \right)$$

Thus for the tension $\frac{T}{2}$ in each string we get

$$\frac{T}{2} = \frac{M \cdot g}{2} \cdot \left(1 + \frac{2 \cdot r^2}{R^2 + 2 \cdot r^2} \right) = \frac{0,40 \cdot 9,81}{2} \cdot \left(1 + \frac{2 \cdot 9 \cdot 10^{-6}}{3,6 \cdot 10^{-3} + 2 \cdot 9 \cdot 10^{-6}} \right) = 1,96 \text{ N}$$

$$\frac{T}{2} = 1,96 \text{ N}$$

2.4

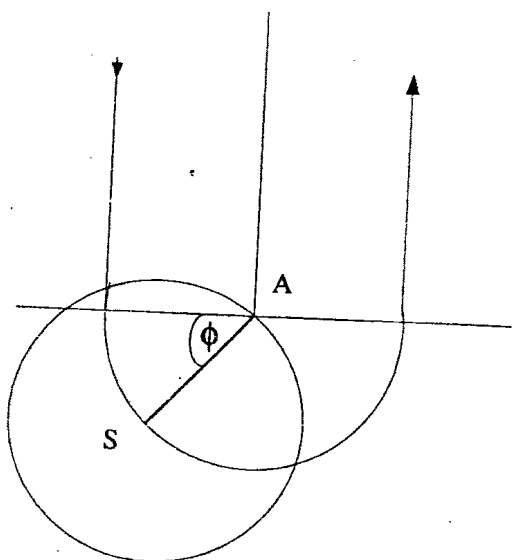

Fig 19.7

After the whole length of the strings is completely unwound, the wheel continues to rotate about A (which is at rest for some interval to be discussed).

Let $\dot{\Phi}$ be the angular speed of the centre of mass about the axis through A.

The equation of the rotational motion of the wheel about A may be written as

$$|\tau| = I_A \cdot \ddot{\Phi},$$

where τ is the torque about A, I_A is the moment of inertia about the axis A and $\ddot{\Phi}$ is the angular acceleration about the axis through A.

Hence $M \cdot g \cdot r \cdot \cos \Phi = I_A \cdot \ddot{\Phi}$

and $\ddot{\Phi} = \frac{M \cdot g \cdot r \cdot \cos \Phi}{I_A}$

Multiplied with $\dot{\Phi}$ gives:

$$\dot{\Phi} \cdot \ddot{\Phi} = \frac{M \cdot g \cdot r \cdot \cos \Phi \cdot \dot{\Phi}}{I_A} \quad \text{or} \quad \frac{1}{2} \cdot \frac{d(\dot{\Phi})^2}{dt} = \frac{M \cdot g \cdot r \cdot \cos \Phi}{I_A} \cdot \frac{d\Phi}{dt}$$

this gives

$$(\dot{\Phi})^2 = \frac{2 \cdot M \cdot g \cdot r \cdot \sin \Phi}{I_A} + C \quad [C = \text{arbitrary constant}]$$

If $\Phi = 0$ [$s = H$] than is $\dot{\Phi} = \omega$

That gives $\omega = \frac{2 \cdot M \cdot g \cdot H}{I_A}$ and therefore $C = \frac{2 \cdot M \cdot g \cdot H}{I_A}$

Putting these results into the equation above one gets

$$\dot{\Phi} = \omega = \sqrt{\frac{2 \cdot M \cdot g \cdot H \cdot \sin \Phi}{I_A} \cdot \left(1 + \frac{r}{H}\right)}$$

For $\frac{r}{H} \ll 1$ we get:

$$\omega = \omega'_{\text{MAX}} = \sqrt{\frac{2 \cdot M \cdot g \cdot H}{I_A}}$$

and

$$v = r \cdot \omega'_{\text{MAX}} = r \cdot \sqrt{\frac{2 \cdot M \cdot g \cdot H}{I_A}}$$

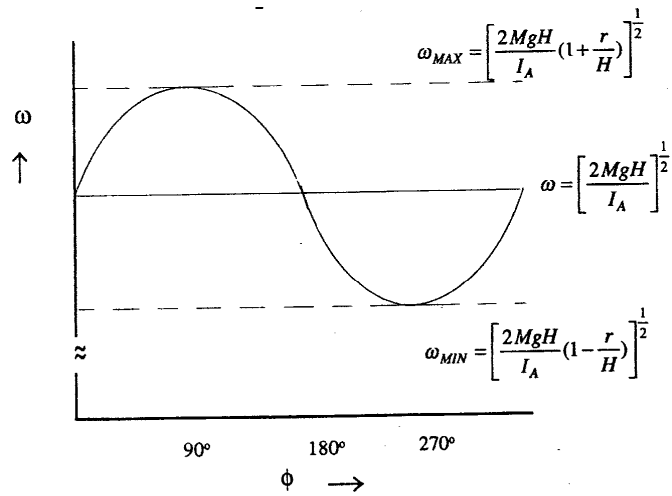

Fig.19.8

Component of the displacement

along x-axis is $x = r \cdot \sin \Phi$

along y-axis is $y = r \cdot \cos \Phi$

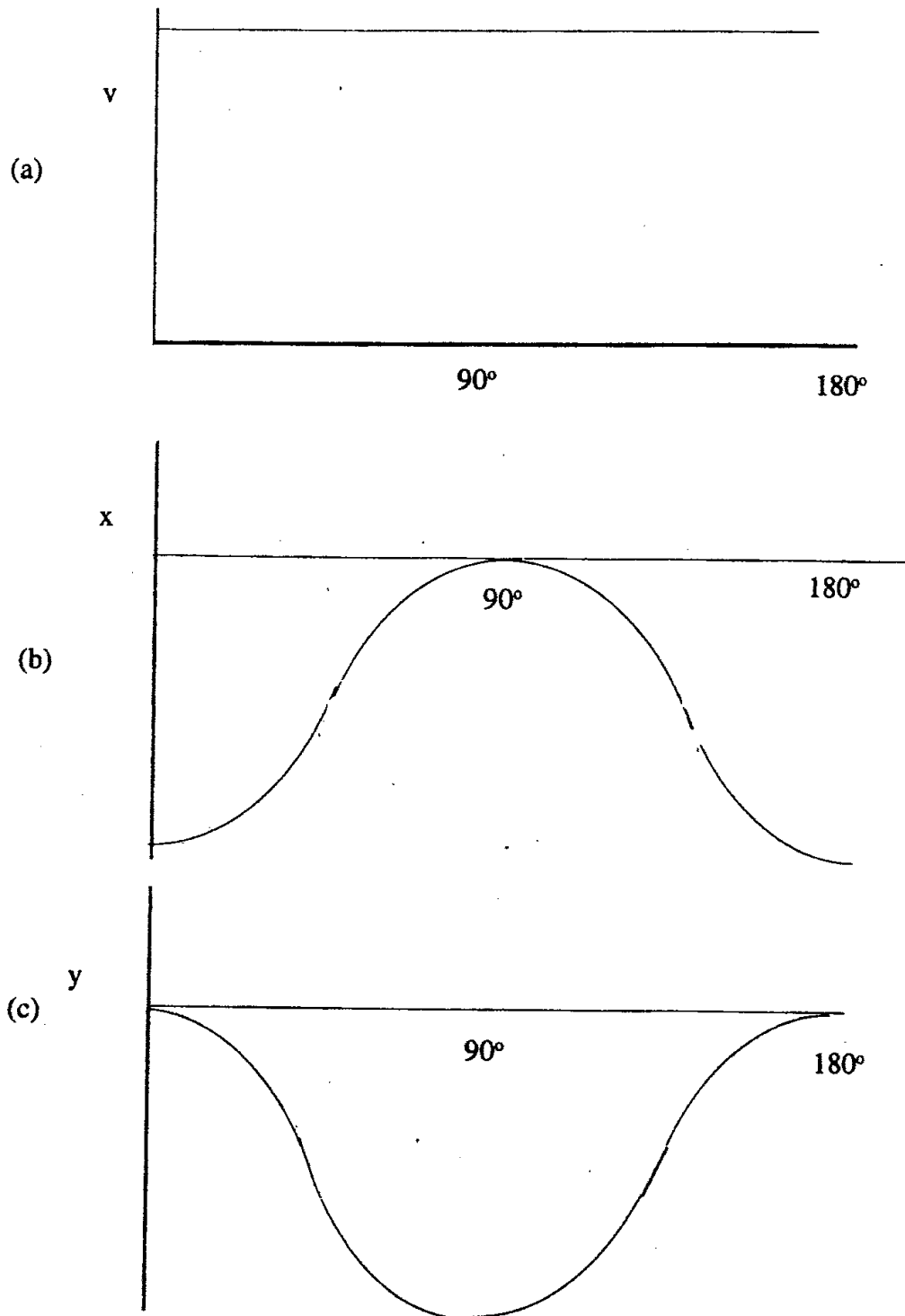

Fig.19.9

IPHO-1988 Bad Ischl / Austria
Problems and Solutions

2.5

Maximum tension in each string occurs $\dot{\Phi} = \omega'_{\text{MAX}}$

The equation of the motion is $T_{\text{MAX}} - M \cdot g = M \cdot (\omega'_{\text{MAX}})^2 \cdot r$

Putting in $T = 20 \text{ N}$ and $\omega'_{\text{MAX}} = \sqrt{\frac{2 \cdot M \cdot g \cdot s}{I_A}}$ (where s is the maximum length of the

strings supporting the wheel without breaking) and $I_A = M \cdot \left(\frac{R^2}{2} + r^2 \right)$ the numbers one

gets:

$$20 = 0,40 \cdot 9,81 \cdot \left(1 + \frac{4 \cdot 3 \cdot 10^{-3} \cdot s}{36 \cdot 10^{-4} + 2 \cdot 9 \cdot 10^{-6}} \right) \quad \text{This gives:} \quad s = 1,24 \text{ m}$$

The maximum length of the strings which support maximum tension without breaking is

$$\boxed{1,24 \text{ m}} .$$

THEORY 3

Recombination of Positive and Negative Ions in Ionized Gas

Introduction

A gas consists of positive ions of some element (at high temperature) and electrons. The positive ion belongs to an atom of unknown mass number Z . It is known that this ion has only one electron in the shell (orbit).

Let this ion be represented by the symbol $A^{(Z-1)+}$

Constants:

electric field constant	$\epsilon_0 = 8,85 \cdot 10^{-12} \frac{\text{A} \cdot \text{s}}{\text{V} \cdot \text{m}}$
elementary charge	$e = \pm 1,602 \cdot 10^{-19} \text{ A} \cdot \text{s}$
	$q^2 = \frac{e^2}{4 \cdot \pi \cdot \epsilon_0} = 2,037 \cdot 10^{-28} \text{ J} \cdot \text{m}$
Planck's constant	$\hbar = 1,054 \cdot 10^{-34} \text{ J} \cdot \text{s}$
(rest) mass of an electron	$m_e = 9,108 \cdot 10^{-31} \text{ kg}$
Bohr's atomic radius	$r_B = \frac{\hbar}{m \cdot q^2} = 5,92 \cdot 10^{-11} \text{ m}$
Rydberg's energy	$E_R = \frac{q^2}{2 \cdot r_B} = 2,180 \cdot 10^{-18} \text{ J}$
(rest) mass of a proton	$m_p \cdot c^2 = 1,503 \cdot 10^{-10} \text{ J}$

Questions:

3.1

Assume that the ion which has just one electron left the shell.

$A^{(Z-1)+}$ is in the ground state.

In the lowest energy state, the square of the average distance of the electron from the nucleus or r^2 with components along x-, y- and z-axis being $(\Delta x)^2$, $(\Delta y)^2$ and $(\Delta z)^2$ respectively and $r_0^2 = (\Delta x)^2 + (\Delta y)^2 + (\Delta z)^2$ and also the square of the average momentum by

$$p_0^2 = (\Delta p_x)^2 + (\Delta p_y)^2 + (\Delta p_z)^2, \text{ whereas } \Delta p_x \geq \frac{\hbar}{2 \cdot \Delta x}, \Delta p_y \geq \frac{\hbar}{2 \cdot \Delta y} \text{ and } \Delta p_z \geq \frac{\hbar}{2 \cdot \Delta z}.$$

Write inequality involving $(p_0)^2 \cdot (r_0)^2$ in a complete form.

3.2

The ion represented by $A^{(Z-1)+}$ may capture an additional electron and consequently emits a photon.

Write down an equation which is to be used for calculation the frequency of an emitted photon.

3.3

Calculate the energy of the ion $A^{(Z-1)+}$ using the value of the lowest energy. The calculation should be approximated based on the following principles:

3.3.A

The potential energy of the ion should be expressed in terms of the average value of $\frac{1}{r}$.

(ie. $\frac{1}{r_0}$; r_0 is given in the problem).

3.3.B

In calculating the kinetic energy of the ion, use the average value of the square of the momentum given in 3.1 after being simplified by $(p_0)^2 \cdot (r_0)^2 \approx (\hbar)^2$

3.4

Calculate the energy of the ion $A^{(Z-2)+}$ taken to be in the ground state, using the same principle as the calculation of the energy of $A^{(Z-1)+}$. Given the average distance of each of the two electrons in the outermost shell (same as r_0 given in 3.3) denoted by r_1 and r_2 , assume the average distance between the two electrons is given by r_1+r_2 and the average value of the square of the momentum of each electron obeys the principle of uncertainty ie.

$$p_1^2 \cdot r_1^2 \approx \hbar^2 \quad \text{and} \quad p_2^2 \cdot r_2^2 \approx \hbar^2$$

hint: Make use of the information that in the ground state $r_1 = r_2$

3.5

Consider in particular the ion $A^{(Z-2)+}$ is at rest in the ground state when capturing an additional electron and the captured electron is also at rest prior to the capturing. Determine the numerical value of Z , if the frequency of the emitted photon accompanying electron capturing is $2,057 \cdot 10^{17}$ rad/s. Identify the element which gives rise to the ion.

Solution

3.1

$$r_0^2 = (\Delta x)^2 + (\Delta y)^2 + (\Delta z)^2$$

$$p_0^2 = (\Delta p_x)^2 + (\Delta p_y)^2 + (\Delta p_z)^2$$

since

$$\Delta p_x \geq \frac{\hbar}{2 \cdot \Delta x} \quad \Delta p_y \geq \frac{\hbar}{2 \cdot \Delta y} \quad \Delta p_z \geq \frac{\hbar}{2 \cdot \Delta z}$$

gives

$$p_0^2 \geq \frac{\hbar^2}{4} \cdot \left[\frac{1}{(\Delta x)^2} + \frac{1}{(\Delta y)^2} + \frac{1}{(\Delta z)^2} \right]$$

and

$$(\Delta x)^2 = (\Delta y)^2 = (\Delta z)^2 = \frac{r_0^2}{3}$$

thus $p_0^2 \cdot r_0^2 \geq \frac{9}{4} \cdot \hbar^2$

3.2

$|\vec{v}_e|$ speed of the external electron before the capture

$|\vec{V}_i|$ speed of $A^{(Z-1)+}$ before capturing

$|\vec{V}_f|$ speed of $A^{(Z-1)+}$ after capturing

$E_n = h \cdot \nu$ energy of the emitted photon

conservation of energy:

$$\frac{1}{2} \cdot m_e \cdot v_e^2 + \frac{1}{2} \cdot (M + m_e) \cdot V_i^2 + E[A^{(Z-1)+}] = \frac{1}{2} \cdot (M + 2 \cdot m_e) \cdot V_f^2 + E[A^{(Z-2)+}]$$

where $E[A^{(Z-1)+}]$ and $E[A^{(Z-2)+}]$ denotes the energy of the electron in the outermost shell of ions $A^{(Z-1)+}$ and $A^{(Z-2)+}$ respectively.

conservation of momentum:

$$m_e \cdot \vec{v}_e + (M + m) \cdot \vec{V}_i = (M + 2 \cdot m_e) \cdot \vec{V}_f + \frac{h \cdot \nu}{c} \cdot \vec{1}$$

where $\vec{1}$ is the unit vector pointing in the direction of the motion of the emitted photon.

3.3

Determination of the energy of $A^{(Z-1)+}$:

$$\text{potential energy} = -\frac{Z \cdot e^2}{4 \cdot \pi \cdot \epsilon_0 \cdot r_0} = -\frac{Z \cdot q^2}{r_0}$$

$$\text{kinetic energy} = \frac{p^2}{2 \cdot m}$$

If the motion of the electrons is confined within the x-y-plane, principles of uncertainty in 3.1 can be written as

$$r_0^2 = (\Delta x)^2 + (\Delta y)^2$$

$$p_0^2 = (\Delta p_x)^2 + (\Delta p_y)^2$$

$$p_0^2 = \frac{\hbar^2}{4} \cdot \left[\frac{1}{(\Delta x)^2} + \frac{1}{(\Delta y)^2} \right] = \frac{\hbar^2}{4} \cdot \left[\frac{2}{r_0^2} + \frac{2}{r_0^2} \right] = \frac{\hbar^2}{4} \cdot \frac{4}{r_0^2}$$

thus

$$p_0^2 \cdot r_0^2 = \hbar^2$$

$$E[A^{(Z-1)+}] = \frac{p_0^2}{2 \cdot m_e} - \frac{Z \cdot q^2}{r_0} = \frac{\hbar^2}{2 \cdot m_e \cdot r_e} - \frac{Z \cdot q^2}{r_0}$$

Energy minimum exists, when $\frac{dE}{dr_0} = 0$.

Hence

$$\frac{dE}{dr_0} = -\frac{\hbar^2}{m_e \cdot r_e^3} + \frac{Z \cdot q^2}{r_0^2} = 0$$

this gives
$$\frac{1}{r_0} = \frac{Z \cdot q^2 \cdot m_e}{\hbar^2}$$

hence

$$E[A^{(Z-1)+}] = \frac{\hbar^2}{2 \cdot m_e} \cdot \left(\frac{Z \cdot q^2 \cdot m_e}{\hbar} \right)^2 - Z \cdot q^2 \cdot \frac{Z \cdot q^2 \cdot m_e}{\hbar^2} = -\frac{m_e}{2} \cdot \left(\frac{Z \cdot q^2}{\hbar} \right)^2 = -\frac{q^2 \cdot Z^2}{2 \cdot r_B} = -E_R \cdot Z^2$$

$$E[A^{(Z-1)+}] = -E_R \cdot Z^2$$

3.4

In the case of $A^{(Z-1)+}$ ion captures a second electron

$$\text{potential energy of both electrons} = -2 \cdot \frac{Z \cdot q^2}{r_0}$$

$$\text{kinetic energy of the two electrons} = 2 \cdot \frac{p^2}{2 \cdot m} = \frac{\hbar^2}{m_e \cdot r_0^2}$$

$$\text{potential energy due to interaction between the two electrons} = \frac{q^2}{|\vec{r}_1 - \vec{r}_2|} = \frac{q^2}{2 \cdot r_0}$$

$$E[A^{(Z-2)+}] = \frac{\hbar^2}{m_e \cdot r_0^2} - \frac{2 \cdot Z \cdot q^2}{r_0^2} + \frac{q^2}{2 \cdot r_0}$$

$$\text{total energy is lowest when } \frac{dE}{dr_0} = 0$$

hence

$$0 = -\frac{2 \cdot \hbar^2}{m_e \cdot r_0^3} + \frac{2 \cdot Z \cdot q^2}{r_0^3} - \frac{q^2}{2 \cdot r_0^2}$$

hence

$$\frac{1}{r_0} = \frac{q^2 \cdot m_e}{2 \cdot \hbar^2} \cdot \left(2 \cdot Z - \frac{1}{2}\right) = \frac{1}{r_B} \cdot \left(Z - \frac{1}{4}\right)$$

$$E[A^{(Z-2)+}] = \frac{\hbar^2}{m_e} \cdot \left(\frac{q^2 \cdot m_e}{2 \cdot \hbar^2}\right)^2 - \frac{q^2 \cdot \left(2 \cdot Z - \frac{1}{2}\right)}{\hbar} \cdot \frac{q^2 \cdot m_e \cdot \left(2 \cdot Z - \frac{1}{2}\right)}{2 \cdot \hbar}$$

$$E[A^{(Z-2)+}] = -\frac{m_e}{4} \cdot \left[\frac{q^2 \cdot \left(2 \cdot Z - \frac{1}{2}\right)}{\hbar}\right]^2 = -\frac{m_e \cdot \left[q^2 \cdot \left(Z - \frac{1}{4}\right)\right]^2}{\hbar^2} = -\frac{q^2 \cdot \left(Z - \frac{1}{4}\right)^2}{\hbar^2}$$

this gives

$$E[A^{(Z-2)+}] = -2 \cdot E_R \cdot \left(Z - \frac{1}{4}\right)^2$$

3.5

The ion $A^{(Z-1)+}$ is at rest when it captures the second electron also at rest before capturing.
From the information provided in the problem, the frequency of the photon emitted is given by

$$\nu = \frac{\omega}{2 \cdot \pi} = \frac{2,057 \cdot 10^{17}}{2 \cdot \pi} \text{ Hz}$$

The energy equation can be simplified to $E[A^{(Z-1)+}] - E[A^{(Z-2)+}] = \hbar \cdot \omega = h \cdot \nu$
that is

$$-E_R \cdot Z^2 - \left[-2 \cdot E_R \cdot \left(Z - \frac{1}{4} \right)^2 \right] = \hbar \cdot \omega$$

putting in known numbers follows

$$2,180 \cdot 10^{-18} \cdot \left[-Z^2 + 2 \cdot \left(Z - \frac{1}{4} \right)^2 \right] = 1,05 \cdot 10^{-34} \cdot 2,607 \cdot 10^{17}$$

this gives

$$Z^2 - Z - 12,7 = 0$$

with the physical sensuous result $Z = \frac{1 + \sqrt{1 + 51}}{2} = 4,1$

This implies $Z = 4$, and that means Beryllium

EXPERIMENTS

EXPERIMENT 1: Polarized Light

General Information

Equipment:

- one electric tungsten bulb made of frosted-surface glass complete with mounting stand, 1 set
- 3 wooden clamps, each of which contains a slit for light experiment
- 2 glass plates; one of which is rectangular and the other one is square-shaped
- 1 polaroid sheet (circular-shaped)
- 1 red film or filter
- 1 roll self adhesive tape
- 6 pieces of self-adhesive labelling tape
- 1 cellophane sheet
- 1 sheet of black paper
- 1 drawing triangle with a handle
- 1 unerasable luminocolour pen 312, extra fine and black colour
- 1 lead pencil type F
- 1 lead pencil type H
- 1 pencil sharpener
- 1 eraser
- 1 pair of scissors

Important Instructions to be Followed

1. There are 4 pieces of labelling tape coded for each contestant. Stick the tape one each on the instrument marked with the sign #. Having done this, the contestant may proceed to perform the experiment to answer the questions.
2. Cutting, etching, scraping or folding the polaroid is strictly forbidden.
3. If marking is to be made on the polaroid, use the lumino-colour pen provided and put the cap back in place after finishing.
4. When marking is to be made on white paper sheet, use the white tape.
5. Use lead pencils to draw or sketch a graph.
6. Black paper may be cut into pieces for use in the experiment, but the best way of using the black paper is to roll it into a cylinder as to form a shield around the electric bulb. An aperture of proper size may be cut into the side of the cylinder to form an outlet for light used in the experiment.
7. Red piece of paper is to be folded to form a double layer.

The following four questions will be answered by performing the experiment:

Questions

1.1

1.1.a

Locate the axis of the light transmission of the polaroid film. This may be done by observing light reflected from the surface of the rectangular glass plate provided. (Light transmitting axis is the direction of vibration of the electric field vector of light wave transmitted through the polaroid). Draw a straight line along the light transmission axis as exactly as possible on the polaroid film. (#)

1.1.b

Set up the apparatus on the graph paper for the experiment to determine the refractive index of the glass plate for white light.

When unpolarized light is reflected at the glass plate, reflected light is partially polarized. Polarization of the reflected light is a maximum if the tangens of incident angle is equal to the refractive index of the glass plate, or: $\tan \alpha = n$.

Draw lines or dots that are related to the determination of the refractive index on the graph paper. (#)

1.2

Assemble a polariscope to observe birefringence in birefringent glass plate when light is normally incident on the plastic sheet and the glass plates.

A birefringent object is the object which splits light into two components, with the electric field vectors of the two components perpendicular to each other. The two directions of the electric field vectors are known as birefringent axes characteristic of birefringent material. These two components of light travel with different velocity.

Draw a simple sketch depicting design and functions of the polariscope assembled.

Insert a sheet of clear cellophane in the path of light in the polariscope. Draw lines to indicate birefringent axes (#). Comment briefly but concisely on what is observed, and describe how birefringent axes are located.

1.3

1.3.a

Stick 10 layers of self-adhesive tape provided on the glass plate as shown below. Make sure that each layer recedes in equal steps.

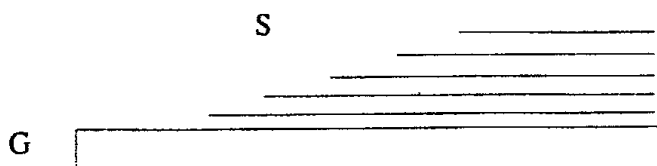

Fig. 19.10

G square glass plate as a substrate for the cellophane layers
T 10 layers of cellophane sheet
S steps about 3 mm up to 4 mm wide

Insert the assembled square plate into the path of light in the polariscope. Describe conditions for observing colours. How can these colours be changed ? Comment on the observations from this experiment.

IPHO-1988 Bad Ischl / Austria
Problems and Solutions

1.3.b

Prepare monochromatic red light by placing doubly-folded red plastic sheet in the path of white light. Mark on the assembled square plate to show the steps which allow the determination of the difference of the optical paths of the two components of light from birefringent phenomenon, described under 1.2 (#).

Estimate the difference of the optical paths from two consecutive steps.

1.4

1.4.a

With the polariscope assembled, examine the central part of the drawing triangle provided. Describe relevant optical properties of the drawing triangle pertaining to birefringence.

1.4.b

Comment on the results observed. Draw conclusions about the physical properties of the material of which the triangle is made.

Additional Cautions

Be sure that the following items affixed with the coded labels provided accompany the report.

1. (#) Polarized film with the position of the transmission axis clearly marked.
2. (#) Graph paper with lines and dots denoting experimental setup for determining refractive index.
3. (#) Sheet of cellophane paper with marking indicating the positions of birefringent axis.
4. (#) Square glass plate affixed with self-adhesive tape with markings to indicate the positions of birefringent axis.

Solution

In this experiment the results from one experimental stage are used to solve problems in the following experimental stages. Without actually performing all parts of the experiment, solution cannot be meaningfully discussed.

It suffices that some transparent crystals are anisotropic, meaning their optical properties vary with the direction. Crystals which have this property are said to be doubly refracting or exhibit birefringence.

This phenomenon can be understood on the basis of wave theory. When a wavefront enters a birefringent material, two sets of Huygens wavelets propagate from every point of the entering wavefront causing the incident light to split into two components of two different velocities. In some crystals there is a particular direction (or rather a set of parallel directions) in which the velocities of the two components are the same. This direction is known as optic axes. The former is said to be uniaxial, and the latter biaxial.

If a plane polarized light (which may be white light or monochromatic light) is allowed to enter a uniaxial birefringent material, with its plane of polarization making some angle, say 45° with the optic axis, the incident light is splitted into two components (ordinary and extraordinary) travelling with two different velocities. Because of different velocities their phases differ.

Upon emerging from the crystal, the two components recombine to form a resultant wave. The phase difference between the two components causes the resultant wave to be either linearly or circularly or elliptical polarized depending on the phase difference between the two components. The type of polarization can be determined by means of an analyser which is a second polaroid sheet provided for this experiment.

EXPERIMENT 2: Electron Tube

Introduction

Free electrons in a metal may be thought of as being “electron gas” confined in potential or energy walls. Under normal conditions or even when a voltage is applied near the surface of the metal, these electrons cannot leave the potential walls (see fig. 19.11)

If however the metal or the electron gas is heated, the electrons have enough thermal energy (kinetic energy) to overcome the energy barrier W (W is known as “work function”). If a voltage is applied across the metal and the anode, these thermally activated electrons may reach the anode.

The number of electrons arriving at the anode per unit time depends on the nature of the cathode and the temperature, i.e. all electrons freed from the potential wall will reach the anode no longer increase with applied voltage (see fig. 19.11)

The saturated current corresponding to the number of thermally activated electrons freed from the metal surface per unit time obeys what is generally known as Richardson’s equation i.e.

$$I_B = C \cdot T^2 \cdot e^{-\frac{W}{k \cdot T}}$$

where

C is a constant

T temperature of the cathode in Kelvin

k Boltzmann’s constant = $1,38 \cdot 10^{-23}$ J/K

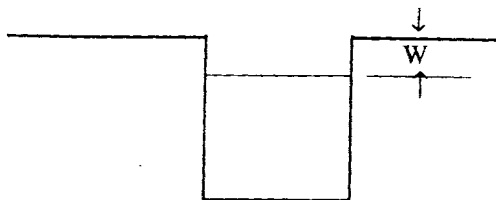
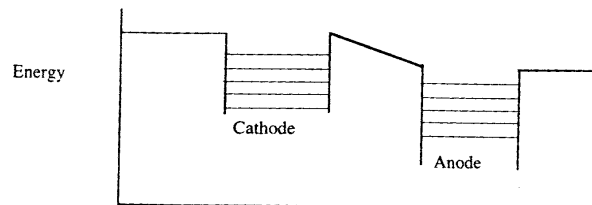

Fig 19.11



Distance

Fig.19.12

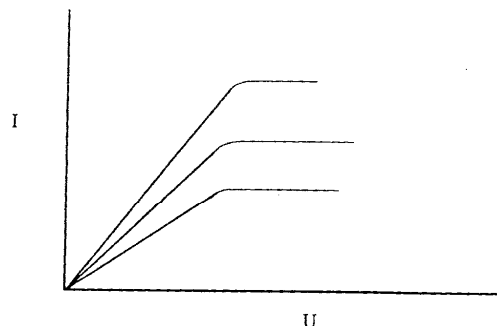

Fig 19.13 Graph of current as a function of voltage across anode-cathode

Determine the value of the work function W of tungsten metal in the form of heating filament of the vacuum tube provided.

IPHO-1988 Bad Ischl / Austria
Problems and Solutions

The following items of equipment are placed at the disposal of the contestants:

- Electron tube AZ 41 which is a high-vacuum, full-wave rectifying diode. The cathode is made from a coated tungsten filament the work function of which is to be ascertained. According to the manual prepared by its manufacturer, no more than 4 V should be used when applying heating current to the cathode. Since the tube has two anodes, it is most desirable to have them connected for all measurements. The diagram in fig. 19.14 is a guide to identifying the anodes and the cathode.
- multimeter 1 unit, internal resistance for voltage measurement: 10 M Ω
- battery 1,5 V (together with a spare)
- battery 9 V; four units can be connected in series as shown in fig. 19.15
- connectors
- resistors; each of which has specifications as follows:
 - 1000 $\Omega \pm 2\%$ (brown, black, black, brown, brown, red)
 - 100 $\Omega \pm 2\%$ (brown, black, black, black, brown, red)
 - 47,5 $\Omega \pm 1\%$ (yellow, violet, green, gold, brown)
- resistors; 4 units, each of which has the resistance of about 1 Ω and coded
- connecting wires
- screw driver
- graph paper (1 sheet)
- graph of specific resistance of tungsten as a function of temperature; 1 sheet

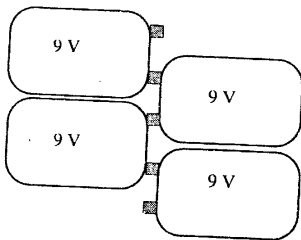

Fig 19.15

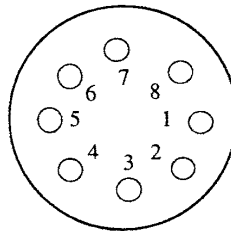
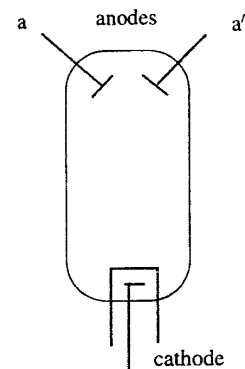

Fig 19.14



Solve the following problems:

2.1

Determine the resistance of 4 numerically-coded resistors. Under no circumstances must the multimeter be used as an ohmmeter.

2.2

Determine the saturated current for 4 different values of cathode temperatures, using 1,5 V battery to heat the cathode filament. A constant value of voltage between 35 V – 40 V between the anode and the cathode is sufficient to produce a saturated current. Obtain this value of voltage by connecting the four 9 V batteries in series. Describe how the different values of temperature are determined.

2.3

Determine the value of W . Explain the procedures used.

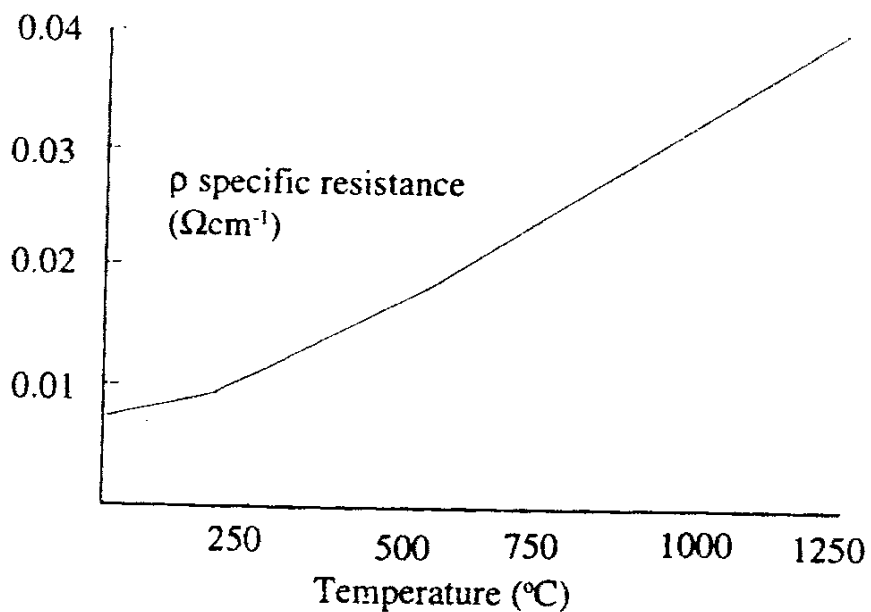

Fig 19.16

Solution

2.1

Connect the circuit as shown in fig. 19.17

R_X resistance to be determined

R known value of resistance

Measure potential difference across R_X and R .
Chose the value of R which gives comparable value of potential difference across R_X .

In this particular case $R = 47,5 \Omega$

$$\frac{R_X}{R} = \frac{V_X}{V}$$

where V_X and V are values of potential differences across R_X and R respectively.

R_X can be calculated from the above equation.

(The error in R_X depends on the errors of V_X and V_R).

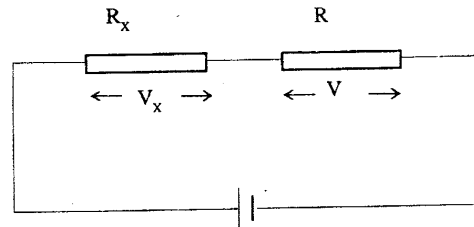

Fig. 19.17

2.2

Connect the circuit as shown in fig. 19.18

- Begin the experiment by measuring the resistance R_0 of the tungsten cathode when there is no heating current
- Add resistor $R = 1000 \Omega$ into the cathode circuit, determine resistance R_1 of the tungsten cathode, calculate the resistance of the current-carrying cathode.
- Repeat the experiment, using the resistor $R = 100 \Omega$ in the cathode circuit, determine resistance R_2 of tungsten cathode with heating current in the circuit.
- Repeat the experiment, using the resistor $R = 47,5 \Omega$ in the cathode circuit, determine resistance R_3 of tungsten cathode with heating current in the circuit.
- Plot a graph of $\frac{R_1}{R_0}$, $\frac{R_2}{R_0}$ and $\frac{R_3}{R_0}$ as a function of temperature, put the value of

$\frac{R_0}{R_0} = 1$ to coincide with room temperature i.e. 18°C approximately and draw the remaining part of the graph parallel to the graph of specific resistance as a function of temperature provided in the problem. From the graph, read values of the temperature of the cathode T_1 , T_2 and T_3 in Kelvin.

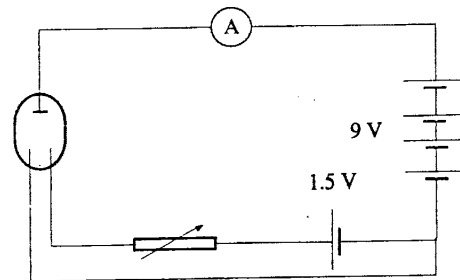

Fig 19.18

IPHO-1988 Bad Ischl / Austria
Problems and Solutions

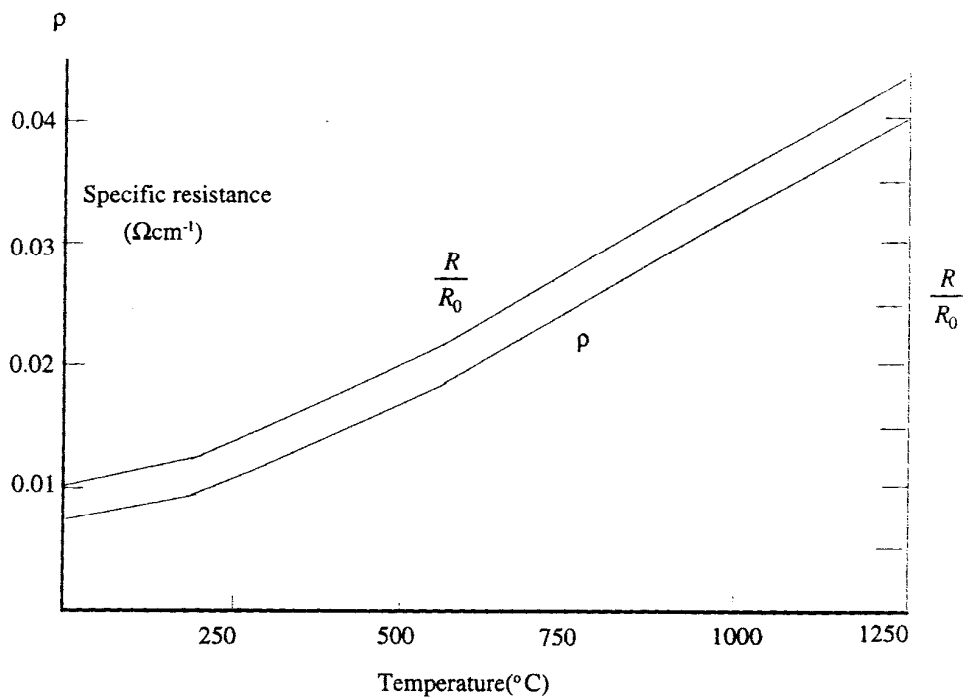

Fig 19.19

From the equation $I = C \cdot T^2 \cdot e^{-\frac{W}{k \cdot T}}$
we get $\ln \frac{I}{T^2} = -\frac{W}{k \cdot T} + \ln C$

Plot a graph of $\ln \frac{I}{T^2}$ against $\frac{1}{T}$.

The curve is linear. Determine the slope m from this graph. $-m = -\frac{W}{k}$

Work function W can be calculated using known values of m and k (given in the problem).

Error in W depends on the error of T which in turn depends on the error of measured R .

Problems of the 20th International Physics Olympiad ¹ (Warsaw, 1989)

Waldemar Gorzkowski

Institute of Physics, Polish Academy of Sciences, Warsaw, Poland ²

Abstract

The article contains problems given at the 20th International Physics Olympiad (1989) and their solutions. The 20th IPhO was the third IPhO organized in Warsaw, Poland.

Logo



The emblem of the XX International Physics Olympiad contains a picture that is a historical record of the first hypernuclear event observed and interpreted in Warsaw by M. Danysz and J. Pniewski³. The collision of a high-energy particle with a heavy nucleus was registered in nuclear emulsion. Tracks of the secondary particles emitted in the event, seen in the picture (upper star), consist of tracks due to fast pions (“thin tracks”) and to much slower fragments of the target nucleus (“black tracks”). The “black track” connecting the upper star (greater) with the lower star (smaller) in the figure is due to a hypernuclear fragment, in this case due to a part of the primary nucleus containing an unstable hyperon Λ instead of a nucleon. Hyperfragments

(hypernuclei) are a new kind of matter in which the nuclei contain not only protons and neutrons but also some other heavy particles.

In the event observed above the hyperon Λ , bound with nucleon, decays like a free particle through a week (slow) process only. This fact strongly suggested the existence of a new quantum number that could explain suppression of the decay, even in presence of nucleons. Indeed, this was one of the observations that, 30 months later, led to the concept of strangeness.

Introduction

Theoretical problems (including solutions and marking schemes) were prepared especially for the 20th IPhO by Waldemar Gorzkowski. The experimental problem (including the solution and marking scheme) was prepared especially for this Olympiad by Andrzej Kotlicki. The problems were refereed independently (and many times) by at least two persons

¹ This article has been sent for publication in *Physics Competitions* in October 2003

² e-mail: gorzk@ifpan.edu.pl

³ M. Danysz and J. Pniewski, *Bull. Acad. Polon. Sci.*, **3(1)** 42 (1952) and *Phil. Mag.*, **44**, 348 (1953). Later the same physicists, Danysz and Pniewski, discovered the first case of a nucleus with two hyperons (double hyperfragment).

after any change was made in the text to avoid unexpected difficulties at the competition. This work was done by:

First Problem:

Andrzej Szadkowski, Andrzej Szymacha, Włodzimierz Ungier

Second Problem:

Andrzej Szadkowski, Andrzej Szymacha, Włodzimierz Ungier, Stanisław Woronowicz

Third Problem:

Andrzej Rajca, Andrzej Szymacha, Włodzimierz Ungier

Experimental Problem:

Krzysztof Korona, Anna Lipniacka, Jerzy Łusakowski, Bruno Sikora

Several English versions of the texts of the problems were given to the English-speaking students. As far as I know it happened for the first time (at present it is typical). The original English version was accepted (as a version for the students) by the leaders of the Australian delegation only. The other English-speaking delegations translated the English originals into English used in their countries. The net result was that there were at least four English versions. Of course, physics contained in them was exactly the same, while wording and spelling were somewhat different (the difference, however, were not too great).

This article is based on the materials quoted at the end of the article and on personal notes of the author.

THEORETICAL PROBLEMS

Problem 1

Consider two liquids A and B insoluble in each other. The pressures p_i ($i = A$ or B) of their saturated vapors obey, to a good approximation, the formula:

$$\ln(p_i / p_o) = \frac{\alpha_i}{T} + \beta_i; \quad i = A \text{ or B,}$$

where p_o denotes the normal atmospheric pressure, T – the absolute temperature of the vapor, and α_i and β_i ($i = A$ or B) – certain constants depending on the liquid. (The symbol \ln denotes the natural logarithm, i.e. logarithm with base $e = 2.7182818\dots$)

The values of the ratio p_i/p_o for the liquids A and B at the temperature 40°C and 90°C are given in Tab. 1.1.

Table 1.1

t [°C]	p_i/p_o	
	$i = A$	$i = B$
40	0.284	0.07278
90	1.476	0.6918

The errors of these values are negligible.

A. Determine the boiling temperatures of the liquids A and B under the pressure p_o .

B. The liquids A and B were poured into a vessel in which the layers shown in Fig. 1.1 were formed. The surface of the liquid B has been covered with a thin layer of a non-volatile liquid C, which is insoluble in the liquids A and B and vice versa, thereby preventing any free evaporation from the upper surface of the liquid B, The ratio of molecular masses of the liquids A and B (in the gaseous phase) is:

$$\gamma = \mu_A / \mu_B = 8.$$

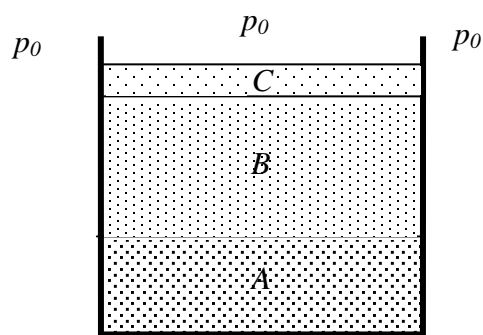

Fig. 1.1

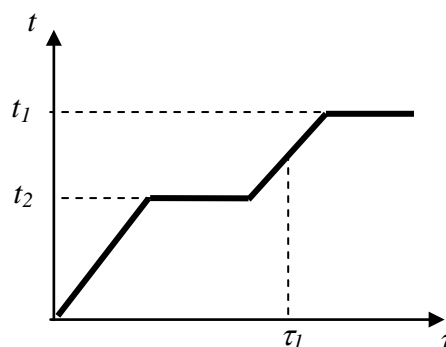

Fig. 1.2

The masses of the liquids A and B were initially the same, each equal to $m = 100\text{g}$. The heights of the layers of the liquids in the vessel and the densities of the liquids are small enough to make the assumption that the pressure in any point in the vessel is practically equal to the normal atmospheric pressure p_0 .

The system of liquids in the vessel is slowly, but continuously and uniformly, heated. It was established that the temperature t of the liquids changed with time τ as shown schematically in the Fig. 1.2.

Determine the temperatures t_1 and t_2 corresponding to the horizontal parts of the diagram and the masses of the liquids A and B at the time τ_1 . The temperatures should be rounded to the nearest degree (in $^{\circ}\text{C}$) and the masses of the liquids should be determined to one-tenth of gram.

REMARK: Assume that the vapors of the liquids, to a good approximation,

(1) obey the Dalton law stating that the pressure of a mixture of gases is equal to the sum of the partial pressures of the gases forming the mixture and

(2) can be treated as perfect gases up to the pressures corresponding to the saturated vapors.

Solution

PART A

The liquid boils when the pressure of its saturated vapor is equal to the external pressure. Thus, in order to find the boiling temperature of the liquid i (i - A or B), one should determine such a temperature T_{bi} (or t_{bi}) for which $p_i/p_0 = 1$.

Then $\ln(p_i / p_0) = 0$, and we have:

$$T_{bi} = -\frac{\alpha_i}{\beta_i}.$$

The coefficients α_i and β_i are not given explicitly. However, they can be calculated from the formula given in the text of the problem. For this purpose one should make use of the numerical data given in the Tab. 1.1.

For the liquid A, we have:

$$\ln 0.284 = \frac{\alpha_A}{(40 + 273.15)\text{K}} + \beta_A,$$

$$\ln 1.476 = \frac{\alpha_A}{(90 + 273.15)\text{K}} + \beta_A.$$

After subtraction of these equations, we get:

$$\ln 0.284 - \ln 1.476 = \alpha_A \left(\frac{1}{40 + 273.15} - \frac{1}{90 + 273.15} \right) \text{K}^{-1}.$$

$$\alpha_A = \frac{\ln \frac{0.284}{1.476}}{\frac{1}{40 + 273.15} - \frac{1}{90 + 273.15}} \text{K} \approx -3748.49 \text{K}.$$

Hence,

$$\beta_A = \ln 0.284 - \frac{\alpha_A}{(40 + 273.15)\text{K}} \approx 10.711.$$

Thus, the boiling temperature of the liquid A is equal to

$$T_{bA} = 3748.49\text{K}/10.711 \approx 349.95 \text{K}.$$

In the Celsius scale the boiling temperature of the liquid A is

$$t_{bA} = (349.95 - 273.15)^\circ\text{C} = 76.80^\circ\text{C} \approx 77^\circ\text{C}.$$

For the liquid B, in the same way, we obtain:

$$\alpha_B \approx -5121.64 \text{K},$$

$$\beta_B \approx 13.735,$$

$$T_{bB} \approx 372.89 \text{K},$$

$$t_{bB} \approx 99.74^\circ\text{C} \approx 100^\circ\text{C}.$$

PART B

As the liquids are in thermal contact with each other, their temperatures increase in time in the same way.

At the beginning of the heating, what corresponds to the left sloped part of the diagram, no evaporation can occur. The free evaporation from the upper surface of the liquid B cannot occur - it is impossible due to the layer of the non-volatile liquid C. The evaporation from the inside of the system is considered below.

Let us consider a bubble formed in the liquid A or in the liquid B or on the surface that separates these liquids. Such a bubble can be formed due to fluctuations or for many other reasons, which will not be analyzed here.

The bubble can get out of the system only when the pressure inside it equals to the external pressure p_0 (or when it is a little bit higher than p_0). Otherwise, the bubble will collapse.

The pressure inside the bubble formed in the volume of the liquid A or in the volume of the liquid B equals to the pressure of the saturated vapor of the liquid A or B, respectively. However, the pressure inside the bubble formed on the surface separating the liquids A and B is equal to the sum of the pressures of the saturated vapors of both these liquids, as then the bubble is in a contact with the liquids A and B at the same time. In the case considered the pressure inside the bubble is greater than the pressures of the saturated vapors of each of the liquids A and B (at the same temperature).

Therefore, when the system is heated, the pressure p_0 is reached first in the bubbles that were formed on the surface separating the liquids. Thus, the temperature t_1 corresponds to a kind of common boiling of both liquids that occurs in the region of their direct contact. The temperature t_1 is for sure lower than the boiling temperatures of the liquids A and B as then the pressures of the saturated vapors of the liquids A and B are less than p_0 (their sum equals to p_0 and each of them is greater than zero).

In order to determine the value of t_1 with required accuracy, we can calculate the values of the sum of the saturated vapors of the liquids A and B for several values of the temperature t and look when one gets the value p_0 .

From the formula given in the text of the problem, we have:

$$\frac{p_A}{p_0} = e^{\frac{\alpha_A + \beta_A}{T}}, \quad (1)$$

$$\frac{p_B}{p_0} = e^{\frac{\alpha_B + \beta_B}{T}}. \quad (2)$$

$p_A + p_B$ equals to p_0 if

$$\frac{p_A}{p_0} + \frac{p_B}{p_0} = 1.$$

Thus, we have to calculate the values of the following function:

$$y(x) = e^{\frac{\alpha_A + \beta_A}{t+t_0}} + e^{\frac{\alpha_B + \beta_B}{t+t_0}},$$

(where $t_0 = 273.15$ °C) and to determine the temperature $t = t_1$, at which $y(t)$ equals to 1. When calculating the values of the function $y(t)$ we can divide the intervals of the temperatures t by 2 (approximately) and look whether the results are greater or less than 1.

We have:

Table 1.2

t	$y(t)$
40°C	< 1 (see Tab. 1.1)
77°C	> 1 (as t_1 is less than t_{bA})
59°C	0.749 < 1
70°C	1.113 > 1
66°C	0.966 < 1
67°C	1.001 > 1
66.5°C	0.983 < 1

Therefore, $t_1 \approx 67^\circ \text{C}$ (with required accuracy).

Now we calculate the pressures of the saturated vapors of the liquids A and B at the temperature $t_1 \approx 67^\circ \text{C}$, i.e. the pressures of the saturated vapors of the liquids A and B in each bubble formed on the surface separating the liquids. From the equations (1) and (2), we get:

$$\begin{aligned} p_A &\approx 0.734 p_0, \\ p_B &\approx 0.267 p_0, \\ (p_A + p_B &= 1.001 p_0 \approx p_0). \end{aligned}$$

These pressures depend only on the temperature and, therefore, they remain constant during the motion of the bubbles through the liquid B. The volume of the bubbles during this motion also cannot be changed without violation of the relation $p_A + p_B = p_0$. It follows from the above remarks that the mass ratio of the saturated vapors of the liquids A and B in each bubble is the same. This conclusion remains valid as long as both liquids are in the system. After total evaporation of one of the liquids the temperature of the system will increase again (second sloped part of the diagram). Then, however, the mass of the system remains constant until the temperature reaches the value t_2 at which the boiling of the liquid (remained in the vessel) starts. Therefore, the temperature t_2 (the higher horizontal part of the diagram) corresponds to the boiling of the liquid remained in the vessel.

The mass ratio m_A/m_B of the saturated vapors of the liquids A and B in each bubble leaving the system at the temperature t_1 is equal to the ratio of the densities of these vapors ρ_A/ρ_B . According to the assumption 2, stating that the vapors can be treated as ideal gases, the last ratio equals to the ratio of the products of the pressures of the saturated vapors by the molecular masses:

$$\frac{m_A}{m_B} = \frac{\rho_A}{\rho_B} = \frac{p_A \mu_A}{p_B \mu_B} = \frac{p_A}{p_B} \mu.$$

Thus,

$$\frac{m_A}{m_B} \approx 22.0.$$

We see that the liquid A evaporates 22 times faster than the liquid B. The evaporation of 100 g of the liquid A during the “surface boiling” at the temperature t_1 is associated with the

evaporation of $100 \text{ g} / 22 \approx 4.5 \text{ g}$ of the liquid B. Thus, at the time τ_1 the vessel contains 95.5 g of the liquid B (and no liquid A). The temperature t_2 is equal to the boiling temperature of the liquid B: $t_2 = 100^\circ\text{C}$.

Marking Scheme

- | | |
|--|----------|
| 1. physical condition for boiling | 1 point |
| 2. boiling temperature of the liquid A (numerical value) | 1 point |
| 3. boiling temperature of the liquid B (numerical value) | 1 point |
| 4. analysis of the phenomena at the temperature t_1 | 3 points |
| 5. numerical value of t_1 | 1 point |
| 6. numerical value of the mass ratio of the saturated vapors in the bubble | 1 point |
| 7. masses of the liquids at the time τ_1 | 1 point |
| 8. determination of the temperature t_2 | 1 point |

REMARK: As the sum of the logarithms is not equal to the logarithm of the sum, the formula given in the text of the problem should not be applied to the mixture of the saturated vapors in the bubbles formed on the surface separating the liquids. However, the numerical data have been chosen in such a way that even such incorrect solution of the problem gives the correct value of the temperature t_1 (within required accuracy). The purpose of that was to allow the pupils to solve the part B of the problem even if they determined the temperature t_1 in a wrong way. Of course, one cannot receive any points for an incorrect determination of the temperature t_1 even if its numerical value is correct.

Typical mistakes in the pupils' solutions

Nobody has received the maximum possible number of points for this problem, although several solutions came close. Only two participants tried to analyze proportion of pressures of the vapors during the upward movement of the bubble through the liquid B. Part of the students confused Celsius degrees with Kelvins. Many participants did not take into account the boiling on the surface separating the liquids A and B, although this effect was the essence of the problem. Part of the students, who did notice this effect, assumed a priori that the liquid with lower boiling temperature "must" be the first to evaporate. In general, this need not be true: if γ were, for example, $1/8$ instead 8 , then liquid A rather than B would remain in the vessel. As regards the boiling temperatures, practically nobody had any essential difficulties.

Problem 2

Three non-collinear points P_1 , P_2 and P_3 , with known masses m_1 , m_2 and m_3 , interact with one another through their mutual gravitational forces only; they are isolated in free space and do not interact with any other bodies. Let σ denote the axis going through the center-of-mass of the three masses, and perpendicular to the triangle $P_1P_2P_3$. What conditions should the angular velocities ω of the system (around the axis σ) and the distances:

$$P_1P_2 = a_{12}, \quad P_2P_3 = a_{23}, \quad P_1P_3 = a_{13},$$

fulfill to allow the shape and size of the triangle $P_1P_2P_3$ unchanged during the motion of the system, i.e. under what conditions does the system rotate around the axis σ as a rigid body?

Solution

As the system is isolated, its total energy, i.e. the sum of the kinetic and potential energies, is conserved. The total potential energy of the points P_1 , P_2 and P_3 with the masses m_1 , m_2 and m_3 in the inertial system (i.e. when there are no inertial forces) is equal to the sum of the gravitational potential energies of all the pairs of points (P_1, P_2) , (P_2, P_3) and (P_1, P_3) . It depends only on the distances a_{12} , a_{23} and a_{31} which are constant in time. Thus, the total potential energy of the system is constant. As a consequence the kinetic energy of the system is constant too. The moment of inertia of the system with respect to the axis σ depends only on the distances from the points P_1 , P_2 and P_3 to the axis σ which, for fixed a_{12} , a_{23} and a_{31} do not depend on time. This means that the moment of inertia I is constant. Therefore, the angular velocity of the system must also be constant:

$$\omega = \text{const.} \quad (1)$$

This is the first condition we had to find. The other conditions will be determined by using three methods described below. However, prior to performing calculations, it is desirable to specify a convenient coordinates system in which the calculations are expected to be simple.

Let the positions of the points P_1 , P_2 and P_3 with the masses m_1 , m_2 and m_3 be given by the vectors \mathbf{r}_1 , \mathbf{r}_2 and \mathbf{r}_3 . For simplicity we assume that the origin of the coordinate system is localized at the center of mass of the points P_1 , P_2 and P_3 with the masses m_1 , m_2 and m_3 and that all the vectors \mathbf{r}_1 , \mathbf{r}_2 and \mathbf{r}_3 are in the same coordinate plane, e.g. in the plane (x, y) . Then the axis σ is the axis z .

In this coordinate system, according to the definition of the center of mass, we have:

$$m_1\mathbf{r}_1 + m_2\mathbf{r}_2 + m_3\mathbf{r}_3 = 0 \quad (2)$$

Now we will find the second condition by using several methods.

FIRST METHOD

Consider the point P_1 with the mass m_1 . The points P_2 and P_3 act on it with the forces:

$$\mathbf{F}_{21} = G \frac{m_1 m_2}{a_{12}^2} (\mathbf{r}_2 - \mathbf{r}_1), \quad (3)$$

$$\mathbf{F}_{31} = G \frac{m_1 m_3}{a_{13}^2} (\mathbf{r}_3 - \mathbf{r}_1). \quad (4)$$

where G denotes the gravitational constant.

In the inertial frame the sum of these forces is the centripetal force

$$\mathbf{F}_{r1} = -m_1 \omega^2 \mathbf{r}_1,$$

which causes the movement of the point P_1 along a circle with the angular velocity ω . (The moment of this force with respect to the axis σ is equal to zero.) Thus, we have:

$$\mathbf{F}_{21} + \mathbf{F}_{31} = \mathbf{F}_{r1}. \quad (5)$$

In the non-inertial frame, rotating around the axis σ with the angular velocity ω , the sum of the forces (3), (4) and the centrifugal force

$$\mathbf{F}'_{r_1} = m_1 \omega^2 \mathbf{r}_1$$

should be equal to zero:

$$\mathbf{F}_{21} + \mathbf{F}_{31} + \mathbf{F}'_{r_1} = 0. \quad (6)$$

(The moment of this sum with respect to any axis equals to zero.)

The conditions (5) and (6) are equivalent. They give the same vector equality:

$$G \frac{m_1 m_2}{a_{12}^3} (\mathbf{r}_2 - \mathbf{r}_1) + G \frac{m_1 m_3}{a_{13}^3} (\mathbf{r}_3 - \mathbf{r}_1) + m_1 \omega^2 \mathbf{r}_1 = 0, \quad (7')$$

$$G \frac{m_1}{a_{12}^3} m_2 \mathbf{r}_2 + G \frac{m_1}{a_{13}^3} m_3 \mathbf{r}_3 + m_1 \mathbf{r}_1 \left(\omega^2 - \frac{Gm_2}{a_{12}^3} - \frac{Gm_3}{a_{13}^3} \right) = 0 \quad (7'')$$

From the formula (2), we get:

$$m_2 \mathbf{r}_2 = -m_1 \mathbf{r}_1 - m_3 \mathbf{r}_3 \quad (8)$$

Using this relation, we write the formula (7) in the following form:

$$G \frac{m_1}{a_{12}^3} (-m_1 \mathbf{r}_1 - m_3 \mathbf{r}_3) + G \frac{m_1}{a_{13}^3} m_3 \mathbf{r}_3 + m_1 \mathbf{r}_1 \left(\omega^2 - \frac{Gm_2}{a_{12}^3} - \frac{Gm_3}{a_{13}^3} \right) = 0,$$

i.e.

$$\mathbf{r}_1 m_1 \left(\omega^2 - \frac{Gm_2}{a_{12}^3} - \frac{Gm_3}{a_{13}^3} - \frac{Gm_1}{a_{12}^3} \right) + \mathbf{r}_3 \left(\frac{1}{a_{13}^3} - \frac{1}{a_{12}^3} \right) Gm_1 m_3 = 0.$$

The vectors \mathbf{r}_1 and \mathbf{r}_3 are non-collinear. Therefore, the coefficients in the last formula must be equal to zero:

$$\left(\frac{1}{a_{13}^3} - \frac{1}{a_{12}^3} \right) Gm_1 m_3 = 0,$$

$$m_1 \left(\omega^2 - \frac{Gm_2}{a_{12}^3} - \frac{Gm_3}{a_{13}^3} - \frac{Gm_1}{a_{12}^3} \right) = 0.$$

The first equality leads to:

$$\frac{1}{a_{13}^3} = \frac{1}{a_{12}^3}$$

and hence,

$$a_{13} = a_{12}.$$

Let $a_{13} = a_{12} = a$. Then the second equality gives:

$$\omega^2 a^3 = GM \quad (9)$$

where

$$M = m_1 + m_2 + m_3 \quad (10)$$

denotes the total mass of the system.

In the same way, for the points P_2 and P_3 , one gets the relations:

a) the point P_2 :

$$a_{23} = a_{12}; \quad \omega^2 a^3 = GM$$

b) the point P_3 :

$$a_{13} = a_{23}; \quad \omega^2 a^3 = GM$$

Summarizing, the system can rotate as a rigid body if all the distances between the masses are equal:

$$a_{12} = a_{23} = a_{13} = a, \quad (11)$$

the angular velocity ω is constant and the relation (9) holds.

SECOND METHOD

At the beginning we find the moment of inertia I of the system with respect to the axis σ . Using the relation (2), we can write:

$$0 = (m_1 \mathbf{r}_1 + m_2 \mathbf{r}_2 + m_3 \mathbf{r}_3)^2 = m_1^2 r_1^2 + m_2^2 r_2^2 + m_3^2 r_3^2 + 2m_1 m_2 \mathbf{r}_1 \mathbf{r}_2 + 2m_1 m_3 \mathbf{r}_1 \mathbf{r}_3 + 2m_3 m_2 \mathbf{r}_3 \mathbf{r}_2.$$

Of course,

$$r_i^2 = r_j^2 \quad i = 1, 2, 3$$

The quantities $2\mathbf{r}_i \mathbf{r}_j$ ($i, j = 1, 2, 3$) can be determined from the following obvious relation:

$$a_{ij}^2 = |\mathbf{r}_i - \mathbf{r}_j|^2 = (\mathbf{r}_i - \mathbf{r}_j)^2 = r_i^2 + r_j^2 - 2\mathbf{r}_i \mathbf{r}_j = r_i^2 + r_j^2 - 2\mathbf{r}_i \mathbf{r}_j.$$

We get:

$$2\mathbf{r}_i \mathbf{r}_j = r_i^2 + r_j^2 - a_{ij}^2.$$

With help of this relation, after simple transformations, we obtain:

$$0 = (m_1 \mathbf{r}_1 + m_2 \mathbf{r}_2 + m_3 \mathbf{r}_3)^2 = (m_1 + m_2 + m_3)(m_1 r_1^2 + m_2 r_2^2 + m_3 r_3^2) - \sum_{i < j} m_i m_j a_{ij}^2.$$

The moment of inertia I of the system with respect to the axis σ , according to the definition of this quantity, is equal to

$$I = m_1 r_1^2 + m_2 r_2^2 + m_3 r_3^2.$$

The last two formulae lead to the following expression:

$$I = \frac{1}{M} \sum_{i < j} m_i m_j a_{ij}^2$$

where M (the total mass of the system) is defined by the formula (10).

In the non-inertial frame, rotating around the axis σ with the angular velocity ω , the total potential energy V_{tot} is the sum of the gravitational potential energies

$$V_{ij} = -G \frac{m_i m_j}{a_{ij}}; \quad i, j = 1, 2, 3; i < j$$

of all the masses and the potential energies

$$V_i = -\frac{1}{2}\omega^2 m_i r_i^2; \quad i = 1, 2, 3$$

of the masses m_i ($i = 1, 2, 3$) in the field of the centrifugal force:

$$\begin{aligned} V_{tot} &= G \sum_{i<j} \frac{m_i m_j}{a_{ij}} - \frac{1}{2} \omega^2 \sum_{i=1}^3 m_i r_i^2 = G \sum_{i<j} \frac{m_i m_j}{a_{ij}} - \frac{1}{2} \omega^2 I = G \sum_{i<j} \frac{m_i m_j}{a_{ij}} - \frac{1}{2} \omega^2 \frac{1}{M} \sum_{i<j} m_i m_j a_{ij}^2 = \\ &= - \sum_{i<j} m_i m_j \left(\frac{\omega^2}{2M} a_{ij}^2 + \frac{G}{a_{ij}} \right) \end{aligned}$$

i.e.

$$V_{tot} = - \sum_{i<j} m_i m_j \left(\frac{\omega^2}{2M} a_{ij}^2 + \frac{G}{a_{ij}} \right).$$

A mechanical system is in equilibrium if its total potential energy has an extremum. In our case the total potential energy V_{tot} is a sum of three terms. Each of them is proportional to:

$$f(a) = \frac{\omega^2}{2M} a^2 + \frac{G}{a}.$$

The extrema of this function can be found by taking its derivative with respect to a and requiring this derivative to be zero. We get:

$$\frac{\omega^2}{M} a - \frac{G}{a^2} = 0.$$

It leads to:

$$\omega^2 a^3 = GM \quad \text{or} \quad \omega^2 a^3 = G(m_1 + m_2 + m_3).$$

We see that all the terms in V_{tot} have extrema at the same values of $a_{ij} = a$. (In addition, the values of a and ω should obey the relation written above.) It is easy to show that it is a maximum. Thus, the quantity V_{tot} has a maximum at $a_{ij} = a$.

This means that our three masses can remain in fixed distances only if these distances are equal to each other:

$$a_{12} = a_{23} = a_{13} = a$$

and if the relation

$$\omega^2 a^3 = GM,$$

where M the total mass of the system, holds. We have obtained the conditions (9) and (11) again.

THIRD METHOD

Let us consider again the point P_1 with the mass m_1 and the forces \mathbf{F}_{21} and \mathbf{F}_{31} given by the formulae (3) and (4). It follows from the text of the problem that the total moment (with respect to any fixed point or with respect to the mass center) of the forces acting on the point P_1 must be equal to zero. Thus, we have:

$$\mathbf{F}_{21} \times \mathbf{r}_1 + \mathbf{F}_{31} \times \mathbf{r}_1 = 0$$

where the symbol \times denotes the vector product. Therefore

$$G \frac{m_1 m_2}{a_{12}^3} (\mathbf{r}_2 - \mathbf{r}_1) \times \mathbf{r}_1 + G \frac{m_1 m_3}{a_{13}^3} (\mathbf{r}_3 - \mathbf{r}_1) \times \mathbf{r}_1 = 0.$$

But

$$\mathbf{r}_1 \times \mathbf{r}_1 = 0.$$

Thus:

$$\frac{m_2}{a_{12}^3} \mathbf{r}_2 \times \mathbf{r}_1 + \frac{m_3}{a_{13}^3} \mathbf{r}_3 \times \mathbf{r}_1 = 0.$$

Using the formula (8), the last relation can be written as follows:

$$\frac{1}{a_{12}^3} (-m_1 \mathbf{r}_1 - m_3 \mathbf{r}_3) \times \mathbf{r}_1 + \frac{m_3}{a_{13}^3} \mathbf{r}_3 \times \mathbf{r}_1 = 0,$$

$$-\frac{m_3}{a_{12}^3} \mathbf{r}_3 \times \mathbf{r}_1 + \frac{m_3}{a_{13}^3} \mathbf{r}_3 \times \mathbf{r}_1 = 0,$$

$$\left(\frac{1}{a_{13}^3} - \frac{1}{a_{12}^3} \right) \mathbf{r}_3 \times \mathbf{r}_1 = 0.$$

The vectors \mathbf{r}_1 and \mathbf{r}_3 are non-collinear (and different from 0). Therefore

$$\mathbf{r}_3 \times \mathbf{r}_1 \neq 0$$

and

$$\frac{1}{a_{13}^3} - \frac{1}{a_{12}^3} = 0,$$

hence,

$$a_{12} = a_{13}.$$

Similarly, one gets:

$$a_{12} = a_{23} (= a).$$

We have re-derived the condition (11).

Taking into account that all the distances a_{ij} have the same value a , from the equation (7) concerning the point P_1 , using the relation (2) we obtain:

$$G \frac{m_1 m_2}{a^3} (\mathbf{r}_2 - \mathbf{r}_1) + G \frac{m_1 m_3}{a^3} (\mathbf{r}_3 - \mathbf{r}_1) + m_1 \omega^2 \mathbf{r}_1 = 0,$$

$$-\left(G \frac{m_1}{a^3} + G \frac{m_2}{a^3} G \frac{m_3}{a^3} \right) m_1 \mathbf{r}_1 + m_1 \omega^2 \mathbf{r}_1 = 0,$$

$$\frac{GM}{a^3} = \omega^2.$$

This is the condition (9). The same condition is got in result of similar calculations for the points P_2 and P_3 .

The method described here does not differ essentially from the first method. In fact they are slight modifications of each other. However, it is interesting to notice how application of a proper mathematical language, e.g. the vector product, simplifies the calculations.

The relation (9) can be called a “generalized Kepler’s law” as, in fact, it is very similar to the Kepler’s law but with respect to the many-body system. As far as I know this generalized Kepler’s law was presented for the first time right at the 20th IPhO.

Marking scheme

- | | |
|--|----------|
| 1. the proof that $\omega = \text{const}$ | 1 point |
| 2. the conditions at the equilibrium (conditions for the forces and their moments or extremum of the total potential energy) | 3 points |
| 3. the proof of the relation $a_{ij} = a$ | 4 points |
| 4. the proof of the relation $\omega^2 a^3 = GM$ | 2 points |

Remarks and typical mistakes in the pupils' solutions

No type of error was observed as predominant in the pupils' solutions. Practically all the mistakes can be put down to the students' scant experience in calculations and general lack of skill. Several students misunderstood the text of the problem and attempted to prove that the three masses should be equal. Of course, this was impossible. Moreover, it was pointless, since the masses were given. Almost all the participants tried to solve the problem by analyzing equilibrium of forces and/or their moments. Only one student tried to solve the problem by looking for a minimum of the total potential energy (unfortunately, his solution was not fully correct). Several participants solved the problem using a convenient reference system: one mass in the origin and one mass on the x -axis. One of them received a special prize.

Problem 3

The problem concerns investigation of transforming the electron microscope with magnetic guiding of the electron beam (which is accelerated with the potential difference $U = 511$ kV) into a proton microscope (in which the proton beam is accelerated with the potential difference $-U$). For this purpose, solve the following two problems:

A. An electron after leaving a device, which accelerated it with the potential difference U , falls into a region with an inhomogeneous field \mathbf{B} generated with a system of stationary coils L_1, L_2, \dots, L_n . The known currents in the coils are i_1, i_2, \dots, i_n , respectively.

What should the currents i_1', i_2', \dots, i_n' in the coils L_1, L_2, \dots, L_n be, in order to guide the proton (initially accelerated with the potential difference $-U$) along the same trajectory (and in the same direction) as that of the electron?

HINT: The problem can be solved by finding a condition under which the equation describing the trajectory is the same in both cases. It may be helpful to use the relation:

$$\mathbf{p} \frac{d}{dt} \mathbf{p} = \frac{1}{2} \frac{d}{dt} \mathbf{p}^2 = \frac{1}{2} \frac{d}{dt} p^2.$$

B. How many times would the resolving power of the above microscope increase or decrease if the electron beam were replaced with the proton beam? Assume that the resolving power of the microscope (i.e. the smallest distance between two point objects whose circular images can be just separated) depends only on the wave properties of the particles.

Assume that the velocities of the electrons and protons before their acceleration are zero, and that there is no interaction between own magnetic moment of either electrons or protons and the magnetic field. Assume also that the electromagnetic radiation emitted by the moving particles can be neglected.

NOTE: Very often physicists use 1 electron-volt (1 eV), and its derivatives such as 1 keV or 1 MeV, as a unit of energy. 1 electron-volt is the energy gained by the electron that passed the potential difference equal to 1 V.

Perform the calculations assuming the following data:

$$\begin{aligned} \text{Rest energy of electron:} & \quad E_e = m_e c^2 = 511 \text{ keV} \\ \text{Rest energy of proton:} & \quad E_p = m_p c^2 = 938 \text{ MeV} \end{aligned}$$

Solution

PART A

At the beginning one should notice that the kinetic energy of the electron accelerated with the potential difference $U = 511 \text{ kV}$ equals to its rest energy E_0 . Therefore, at least in the case of the electron, the laws of the classical physics cannot be applied. It is necessary to use relativistic laws.

The relativistic equation of motion of a particle with the charge e in the magnetic field **B** has the following form:

$$\frac{d}{dt} \mathbf{p} = \mathbf{F}_L$$

where $\mathbf{p} = m_0 \gamma \mathbf{v}$ denotes the momentum of the particle (vector) and

$$\mathbf{F}_L = e \mathbf{v} \times \mathbf{B}$$

is the Lorentz force (its value is $e v B$ and its direction is determined with the right hand rule). m_0 denotes the (rest) mass of the particle and v denotes the velocity of the particle. The quantity γ is given by the formula:

$$\gamma = \frac{1}{\sqrt{1 - \frac{v^2}{c^2}}}$$

The Lorentz force \mathbf{F}_L is perpendicular to the velocity \mathbf{v} of the particle and to its momentum $\mathbf{p} = m_0 \gamma \mathbf{v}$. Hence,

$$\mathbf{F}_L \cdot \mathbf{v} = \mathbf{F}_L \cdot \mathbf{p} = 0.$$

Multiplying the equation of motion by \mathbf{p} and making use of the hint given in the text of the problem, we get:

$$\frac{1}{2} \frac{d}{dt} p^2 = 0.$$

It means that the value of the particle momentum (and the value of the velocity) is constant during the motion:

$$p = m_0 v \gamma = \text{const}; \quad v = \text{const}.$$

The same result can be obtained without any formulae in the following way:

The Lorentz force \mathbf{F}_L is perpendicular to the velocity \mathbf{v} (and to the momentum p as $\mathbf{p} = m_0 \gamma \mathbf{v}$) and, as a consequence, to the trajectory of the particle. Therefore, there is no force that could change the component of the momentum tangent to the trajectory. Thus, this component, whose value is equal to the length of \mathbf{p} , should be constant: $p = \text{const}$. (The same refers to the component of the velocity tangent to the trajectory as $\mathbf{v} = m_0 \gamma \mathbf{v}$).

Let s denotes the path passed by the particle along the trajectory. From the definition of the velocity, we have:

$$\frac{ds}{dt} = v.$$

Using this formula, we can rewrite the equation of motion as follows:

$$v \frac{d}{ds} \mathbf{p} = \frac{ds}{dt} \frac{d}{ds} \mathbf{p} = \frac{d}{dt} \mathbf{p} = \mathbf{F}_L,$$

$$\frac{d}{ds} \mathbf{p} = \frac{\mathbf{F}_L}{v}.$$

Dividing this equation by p and making use of the fact that $p = \text{const}$, we obtain:

$$v \frac{d}{ds} \frac{\mathbf{p}}{p} = \frac{\mathbf{F}_L}{vp}$$

and hence

$$\frac{d}{ds} \mathbf{t} = \frac{\mathbf{F}_L}{vp}$$

where $\mathbf{t} = \mathbf{p}/p = \mathbf{v}/v$ is the versor (unit vector) tangent to the trajectory. The above equation is exactly the same for both electrons and protons if and only if the vector quantity:

$$\frac{\mathbf{F}_L}{vp}$$

is the same in both cases.

Denoting corresponding quantities for protons with the same symbols as for the electrons, but with primes, one gets that the condition, under which both electrons and protons can move along the same trajectory, is equivalent to the equality:

$$\frac{\mathbf{F}_L}{vp} = \frac{\mathbf{F}'_L}{v'p'}.$$

However, the Lorentz force is proportional to the value of the velocity of the particle, and the directions of any two vectors of the following three: \mathbf{t} (or \mathbf{v}), \mathbf{F}_L , \mathbf{B} determine the direction of the third of them (right hand rule). Therefore, the above condition can be written in the following form:

$$\frac{e\mathbf{B}}{p} = \frac{e'\mathbf{B}'}{p'}.$$

Hence,

$$\mathbf{B}' = \frac{e}{e'} \frac{p'}{p} \mathbf{B} = \frac{p'}{p} \mathbf{B}.$$

This means that at any point the direction of the field \mathbf{B} should be conserved, its orientation should be changed into the opposite one, and the value of the field should be multiplied by the same factor p'/p . The magnetic field \mathbf{B} is a vector sum of the magnetic fields of the coils that are arbitrarily distributed in the space. Therefore, each of these fields should be scaled with the same factor $-p'/p$. However, the magnetic field of any coil is proportional to the current flowing in it. This means that the required scaling of the fields can only be achieved by the scaling of all the currents with the same factor $-p'/p$:

$$i'_n = -\frac{p'}{p} i_n.$$

Now we shall determine the ratio p'/p . The kinetic energies of the particles in both cases are the same; they are equal to $E_k = e|U| = 511 \text{ keV}$. The general relativistic relation between the total energy E of the particle with the rest energy E_0 and its momentum p has the following form:

$$E^2 = E_0^2 + p^2 c^2$$

where c denotes the velocity of light.

The total energy of considered particles is equal to the sum of their rest and kinetic energies:

$$E = E_0 + E_k.$$

Using these formulae and knowing that in our case $E_k = e|U| = E_e$, we determine the momenta of the electrons (p) and the protons (p'). We get:

a) electrons:

$$(E_e + E_e)^2 = E_e^2 + p^2 c^2,$$

$$p = \frac{E_e}{c} \sqrt{3}.$$

b) protons

$$(E_p + E_e)^2 = E_p^2 + p'^2 c^2,$$

$$p' = \frac{E_e}{c} \sqrt{\left(\frac{E_p}{E_e} + 1\right)^2 - \left(\frac{E_p}{E_e}\right)^2}.$$

Hence,

$$\frac{p'}{p} = \frac{1}{\sqrt{3}} \sqrt{\left(\frac{E_p}{E_e} + 1\right)^2 - \left(\frac{E_p}{E_e}\right)^2} \approx 35.0$$

and

$$i'_n = -35.0 i_n.$$

It is worthwhile to notice that our protons are 'almost classical', because their kinetic energy $E_k (= E_e)$ is small compared to the proton rest energy E_p . Thus, one can expect that the momentum of the proton can be determined, with a good accuracy, from the classical considerations. We have:

$$E_e = E_k = \frac{p'^2}{2m_p} = \frac{p'^2 c^2}{2m_p c^2} = \frac{p'^2 c^2}{2E_p},$$

$$p' = \frac{1}{c} \sqrt{2E_e E_p}.$$

On the other hand, the momentum of the proton determined from the relativistic formulae can be written in a simpler form since $E_p/E_e \gg 1$. We get:

$$p' = \frac{E_e}{c} \sqrt{\left(\frac{E_p}{E_e} + 1\right)^2 - \left(\frac{E_p}{E_e}\right)^2} = \frac{E_e}{c} \sqrt{2\frac{E_p}{E_e} + 1} \approx \frac{E_e}{c} \sqrt{2\frac{E_p}{E_e}} = \frac{1}{c} \sqrt{2E_e E_p}.$$

In accordance with our expectations, we have obtained the same result as above.

PART B

The resolving power of the microscope (in the meaning mentioned in the text of the problem) is proportional to the wavelength, in our case to the length of the de Broglie wave:

$$\lambda = \frac{h}{p}$$

where h denotes the Planck constant and p is the momentum of the particle. We see that λ is inversely proportional to the momentum of the particle. Therefore, after replacing the electron beam with the proton beam the resolving power will be changed by the factor $p/p' \approx 1/35$. It means that our proton microscope would allow observation of the objects about 35 times smaller than the electron microscope.

Marking scheme

- | | |
|--|----------|
| 1. the relativistic equation of motion | 1 point |
| 2. independence of p and v of the time | 1 point |
| 3. identity of $e\mathbf{B}/p$ in both cases | 2 points |
| 4. scaling of the fields and the currents with the same factor | 1 point |
| 5. determination of the momenta (relativistically) | 1 point |
| 6. the ratio of the momenta (numerically) | 1 point |
| 7. proportionality of the resolving power to λ | 1 point |
| 8. inverse proportionality of λ to p | 1 point |
| 9. scaling of the resolving power | 1 point |

Remarks and typical mistakes in the pupils' solutions

Some of the participants tried to solve the problem by using laws of classical mechanics only. Of course, this approach was entirely wrong. Some students tried to find the required condition by equating "accelerations" of particles in both cases. They understood the "acceleration" of the particle as a ratio of the force acting on the particle to the "relativistic" mass of the particle. This approach is incorrect. First, in relativistic physics the relationship between force and acceleration is more complicated. It deals with not one "relativistic" mass,

but with two "relativistic" masses: transverse and longitudinal. Secondly, identity of trajectories need not require equality of accelerations.

The actual condition, i.e. the identity of $e\mathbf{B}/p$ in both cases, can be obtained from the following two requirements:

- 1° in any given point of the trajectory the curvature should be the same in both cases;
- 2° in the vicinity of any given point the plane containing a small arc of the trajectory should be oriented in space in both cases in the same way.

Most of the students followed the approach described just above. Unfortunately, many forgot about the second requirement (they neglected the vector character of the quantity $e\mathbf{B}/p$).

EXPERIMENTAL PROBLEM¹

The following equipment is provided:

1. Two piezoelectric discs of thickness 10 mm with evaporated electrodes (Fig. 4.1) fixed in holders on the jaws of the calipers;

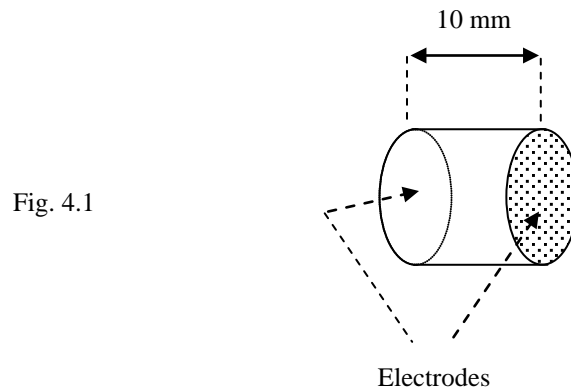

Fig. 4.1

2. The calibrated sine wave oscillator with a photograph of the control panel, explaining the functions of the switches and regulators;
3. A double channel oscilloscope with a photograph of the control panel, explaining the functions of the switches and regulators;
4. Two closed plastic bags containing liquids;
5. A beaker with glycerin (for wetting the discs surfaces to allow better mechanical coupling);
6. Cables and a three way connector;
7. A stand for support the bags with the liquids;
8. Support and calipers.

A piezoelectric material changes its linear dimensions under the influence of an electric field and vice-versa, the distortion of a piezoelectric material induces an electrical field. Therefore, it is possible to excite the mechanical vibrations in a piezoelectric material by applying an alternating electric field, and also to induce an alternating electric field by mechanical vibrations.

¹ The Organizing Committee planned to give another experimental problem: a problem on high T_c superconductivity. Unfortunately, the samples of superconductors, prepared that time by a factory, were of very poor quality. Moreover, they were provided after a long delay. Because of that the organizers decided to use this problem, which was also prepared, but considered as a second choice.

A. Knowing that the velocity of longitudinal ultrasonic waves in the material of the disc is about $4 \cdot 10^3$ m/s, estimate roughly the resonant frequency of the mechanical vibrations parallel to the disc axis. Assume that the disc holders do not restrict the vibrations. (Note that other types of resonant vibrations with lower or higher frequencies may occur in the discs.)

Using your estimation, determine experimentally the frequency for which the piezoelectric discs work best as a transmitter-receiver set for ultrasound in the liquid. Wetting surfaces of the discs before putting them against the bags improves penetration of the liquid in the bag by ultrasound.

B. Determine the velocity of ultrasound for both liquids without opening the bags and estimate the error.

C. Determine the ratio of the ultrasound velocities for both liquids and its error.

Complete carefully the synopsis sheet. Your report should, apart from the synopsis sheet, contain the descriptions of:

- method of resonant frequency estimation;
- methods of measurements;
- methods of estimating errors of the measured quantities and of final results.

Remember to define all the used quantities and to explain the symbols.

Synopsis Sheet¹			
A	Formula for estimating the resonant frequency:	Results (with units):	
	Measured best transmitter frequency (with units):	Error:	
B	Definition of measured quantity:	Symbol:	Results: Error:
	Final formula for ultrasound velocity in liquid:		
	Velocity of ultrasound (with units):		Error:
	Liquid A		
Liquid B			
	Ratio of velocities:	Error:	

Solution (draft)¹

¹ In the real Synopsis Sheet the students had more space for filling.

A. As the holders do not affect vibrations of the disc we may expect antinodes on the flat surfaces of the discs (Fig. 4.2; geometric proportions not conserved). One of the frequencies is expected for

$$l = \frac{1}{2}\lambda = \frac{v}{2f},$$

where v denotes the velocity of longitudinal ultrasonic wave (its value is given in the text of the problem), f - the frequency and l - the thickness of the disc. Thus:

$$f = \frac{v}{2l}.$$

Numerically $f = 2 \cdot 10^5 \text{ Hz} = 200 \text{ kHz}$.

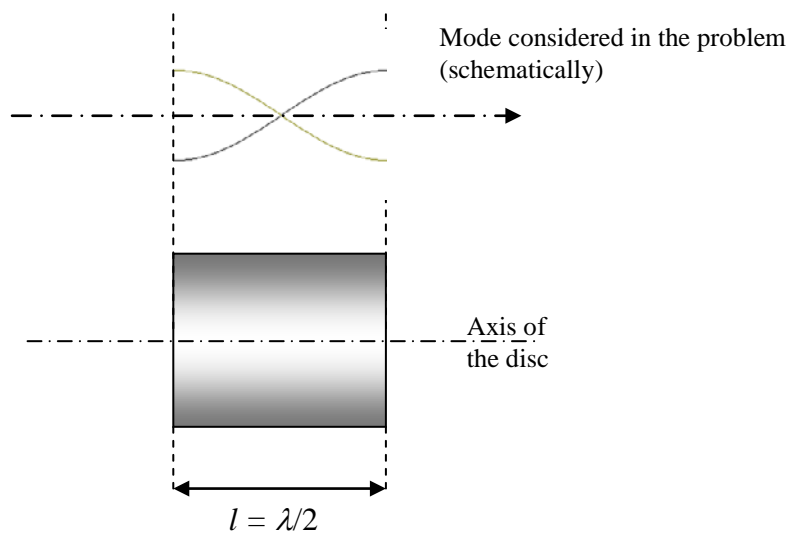

Fig. 4.2

One should stress out that different modes of vibrations can be excited in the disc with height comparable to its diameter. We confine our considerations to the modes related to longitudinal waves moving along the axis of the disc as the sound waves in liquids are longitudinal. We neglect coupling between different modes and require antinodes exactly at the flat parts of the disc. We assume also that the piezoelectric effect does not affect velocity of ultrasound. For these reasons the frequency just determined should be treated as only a rough approximation. However, it indicates that one should look for the resonance in vicinity of 200 kHz.

The experimental set-up is shown in Fig. 4.3. The oscillator (generator) is connected to one of the discs that works as a transmitter and to one channel of the oscilloscope. The second disc is connected to the second channel of the oscilloscope and works as a receiver. Both discs are placed against one of the bags with liquid (Fig. 4.4). The distance d can be varied.

¹ This draft solution is based on the camera-ready text of the more detailed solution prepared by Dr. Andrzej Kotlicki and published in the proceedings [3]

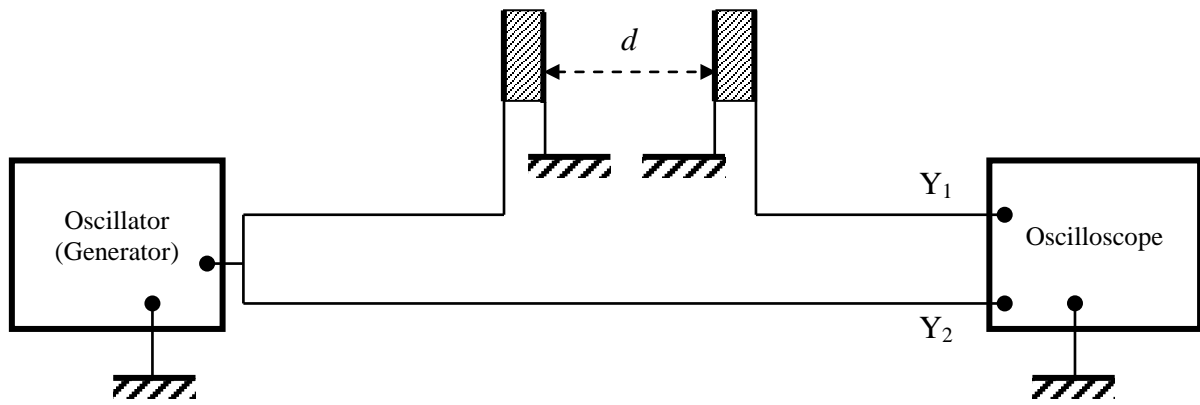

Fig. 4.3

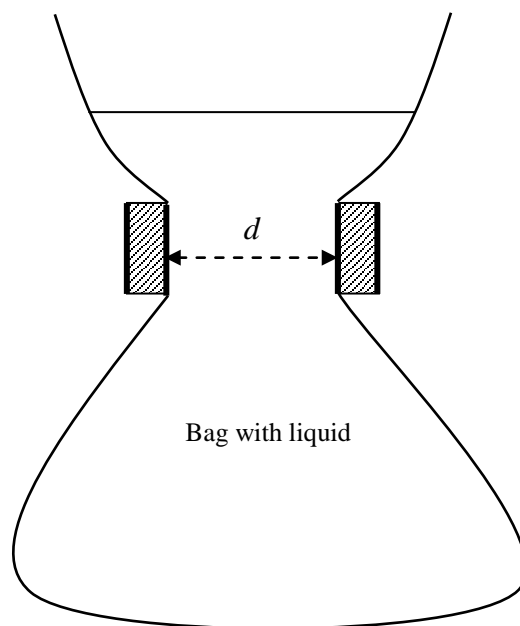

Fig. 4.4

One searches for the resonance by slowly changing the frequency of the oscillator in the range 100 – 1000 kHz and watching the signal on the oscilloscope. In this way the students could find a strong resonance at frequency $f \approx 220$ kHz. Other resonance peaks could be found at about 110 kHz and 670 kHz. They should have been neglected as they are substantially weaker. (They correspond to some other modes of vibrations.) Accuracy of these measurements was 10 kHz (due to the width of the resonance and the accuracy of the scale on the generator).

B. The ultrasonic waves pass through the liquid and generate an electric signal in the receiver. Using the same set-up (Fig. 4.3 and 4.4) we can measure dependence of the phase shift between the signals at Y_1 and Y_2 vs. distance between the piezoelectric discs d at the constant frequency found in point A. This phase shift is $\Delta\varphi = 2\pi df / v_l + \varphi_0$, where v_l denotes velocity of ultrasound in the liquid. φ_0 denotes a constant phase shift occurring when ultrasound passes through the bag walls (possibly zero). The graph representing dependence $d(\Delta\varphi)$ should be a straight line. Its slope allows to determine v_l and its error. In general, the

measurements of $\Delta\varphi$ are difficult for many reflections in the bag, which perturb the signal. One of the best ways is to measure d only for $\Delta\varphi = n\pi$ (n - integer) as such points can be found rather easy. Many technical details concerning measurements can be found in [3] (pp. 37 and 38).

The liquids given to the students were water and glycerin. In the standard solution the author of the problem received the following values:

$$v_{\text{water}} = (1.50 \pm 0.10) \cdot 10^3 \text{ m/s}; \quad v_{\text{glycerin}} = (1.96 \pm 0.10) \cdot 10^3 \text{ m/s}.$$

The ratio of these values was 1.31 ± 0.15 .

The ultrasonic waves are partly reflected or scattered by the walls of the bag. This effect somewhat affects measurements of the phase shift. To minimize its role one can measure the phase shift (for a given distance) or distance (at the same phase shift) several times, each time changing the shape of the bag. As regards errors in determination of velocities it is worth to mention that the most important factor affecting them was the error in determination of the frequency. This error, however, practically does not affect the ratio of velocities.

Marking Scheme

Frequency estimation

- | | |
|---|----------|
| 1. Formula | 1 point |
| 2. Result (with units) | 1 point |
| 3. Method of experimental determining the resonance frequency | 1 point |
| 4. Result (if within 5% of standard value) | 2 points |
| 5. Error | 1 point |

Measurements of velocities

- | | |
|--|----------|
| 1. Explanation of the method | 2 points |
| 2. Proper number of measurements in each series | 3 points |
| 3. Result for velocity in the first liquid (if within 5% of standard value) | 2 points |
| 4. Error of the above | 1 point |
| 5. Result for velocity in the second liquid (if within 5% of standard value) | 2 points |
| 6. Error of the above | 1 point |

Ratio of velocities

- | | |
|--|----------|
| 1. Result (if within 3% of standard value) | 2 points |
| 2. Error of the above | 1 point |

Typical mistakes

The results of this problem were very good (more than a half of competitors obtained more than 15 points). Nevertheless, many students encountered some difficulties in estimation of the frequency. Some of them assumed presence of nodes at the flat surfaces of the discs (this assumption is not adequate to the situation, but accidentally gives proper formula). In part B some students tried to find distances between nodes and antinodes for ultrasonic standing wave in the liquid. This approach gave false results as the pattern of standing waves in the bag is very complicated and changes when the shape of the bag is changed.

Acknowledgement

I would like to thank very warmly to Prof. Jan Mostowski and Dr. Andrzej Wyszomółek for reading the text of this article and for valuable critical remarks. I express special thanks to Dr. Andrzej Kotlicki for critical reviewing the experimental part of the article and for a number of very important improvements.

Literature

[1] **Waldemar Gorzkowski** and **Andrzej Kotlicki**, *XX Międzynarodowa Olimpiada Fizyczna - cz. I*, *Fizyka w Szkole nr 1/90*, pp. 34 - 39

[2] **Waldemar Gorzkowski**, *XX Międzynarodowa Olimpiada Fizyczna - cz. II*, *Fizyka w Szkole nr 2/3-90*, pp. 23 - 32

[3] *XX International Physics Olympiad - Proceedings of the XX International Physics Olympiad, Warsaw (Poland), July 16 - 24, 1989*, ed. by W. Gorzkowski, World Scientific Publishing Company, Singapore 1990 [ISBN 981-02-0084-6]

**THE 21st INTERNATIONAL PHYSICS OLYMPIAD - 1990
GRONINGEN, THE NETHERLANDS**

Hans Jordens

Department of Science and Technology, University of Groningen, The Netherlands.

Question 1. X-ray Diffraction from a crystal.

We wish to study X-ray diffraction by a cubic crystal lattice. To do this we start with the diffraction of a plane, monochromatic wave that falls perpendicularly on a 2-dimensional grid that consists of $N_1 \times N_2$ slits with separations d_1 and d_2 . The diffraction pattern is observed on a screen at a distance L from the grid. The screen is parallel to the grid and L is much larger than d_1 and d_2 .

- a - Determine the positions and widths of the principal maximum on the screen.
The width is defined as the distance between the minima on either side of the maxima.

We consider now a cubic crystal, with lattice spacing a and size $N_0 \cdot a \times N_0 \cdot a \times N_1 \cdot a$. N_1 is much smaller than N_0 . The crystal is placed in a parallel X-ray beam along the z -axis at an angle Θ (see Fig. 1). The diffraction pattern is again observed on a screen at a great distance from the crystal.

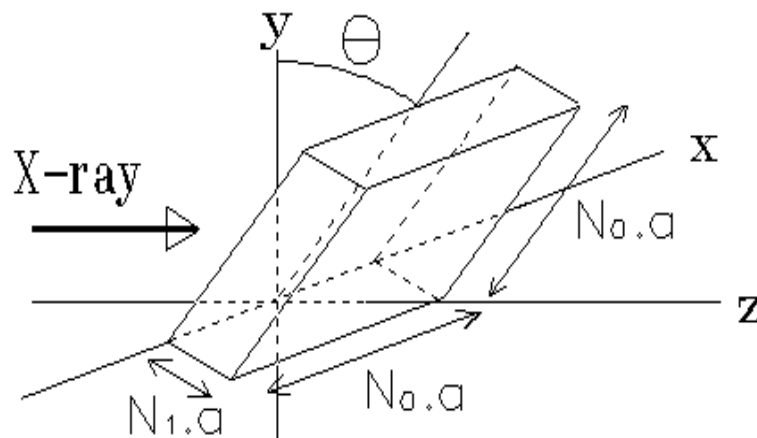

Figure 1 Diffraction of a parallel X-ray beam along the z -axis. The angle between the crystal and the y -axis is Θ .

- b - Calculate the position and width of the maxima as a function of the angle Θ (for small Θ).
- What in particular are the consequences of the fact that $N_1 \ll N_0$.

The diffraction pattern can also be derived by means of Bragg's theory, in which it is assumed that the X-rays are reflected from atomic planes in the lattice. The diffraction pattern then arises from interference of these reflected rays with each other.

- c - Show that this so-called Bragg reflection yields the same conditions for the maxima as those that you found in b.

In some measurements the so-called powder method is employed. A beam of X-rays is scattered by a powder of very many, small crystals. (Of course the sizes of the crystals are much larger than the lattice spacing, a).

Scattering of X-rays of wavelength 0.15 nm by Potassium Chloride [KCl] (which has a cubic lattice, see Fig.2) results in the production of concentric dark circles on a photographic plate. The distance between the crystals and the plate is 0.10 m, and the radius of the smallest circle is 0.053 m (see Fig. 3). K^+ and Cl^- ions have almost the same size, and they may be treated as identical scattering centres.

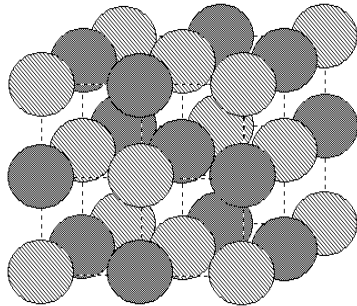

Figure 2. The cubic lattice of Potassium Chloride in which the K^+ and Cl^- ions have almost the same size.

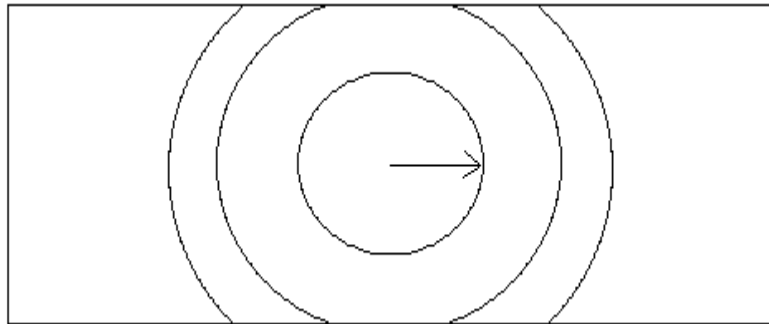

Figure 3. Scattering of X-rays by a powder of KCl crystals results in the production of concentric dark circles on a photographic plate.

d - Calculate the distance between two neighbouring K ions in the crystal.

Question 2. Electric experiments in the magnetosphere of the earth.

In May 1991 the spaceship Atlantis will be placed in orbit around the earth. We shall assume that this orbit will be circular and that it lies in the earth's equatorial plane. At some predetermined moment the spaceship will release a satellite S, which is attached to a conducting rod of length L . We suppose that the rod is rigid, has negligible mass, and is covered by an electrical insulator. We also neglect all friction. Let α be the angle that the rod makes to the line between the Atlantis and the centre of the earth. (see Fig. 1).

S also lies in the equatorial plane.

Assume that the mass of the satellite is much smaller than that of the Atlantis, and that L is much smaller than the radius of the orbit.

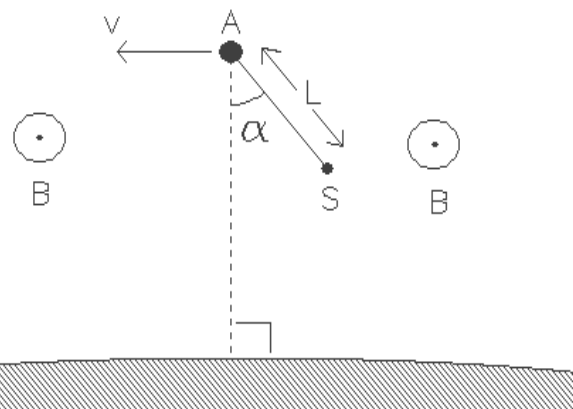

a₁ - Deduce for which value(s) of α the configuration of the spaceship and satellite remain unchanged (with respect to the earth)? In other words, for which value(s) of α is α constant?

Figure 1 The spaceship Atlantis (A) with a satellite (S) in an orbit around the earth. The orbit lies in the earth's equatorial plane. The magnetic field (B) is perpendicular to the diagram and is directed towards the reader.

a₂ - Discuss the stability of the equilibrium for each case.

Suppose that, at a given moment, the rod deviates from the stable configuration by a small angle. The system will begin to swing like a pendulum.

b - Express the period of the swinging in terms of the period of revolution of the system around the earth.

In Fig. 1 the magnetic field of the earth is perpendicular to the diagram and is directed towards the reader. Due to the orbital velocity of the rod, a potential difference arises between its ends. The environment (the magnetosphere) is a rarefied, ionised gas with a very good electrical conductivity. Contact with the ionised gas is made by means of electrodes in A (the Atlantis) and S (the satellite). As a consequence of the motion, a current, I, flows through the rod.

c₁ - In which direction does the current flow through the rod? (Take $\alpha = 0$)

Data:	- the period of the orbit	$T = 5,4 \cdot 10^3 \text{ s}$
	- length of the rod	$L = 2,0 \cdot 10^4 \text{ m}$
	- magnetic field strength of the earth at the height of the satellite	$B = 5,0 \cdot 10^{-5} \text{ Wb.m}^{-2}$
	- the mass of the shuttle Atlantis	$m = 1,0 \cdot 10^5 \text{ kg}$

Next, a current source inside the shuttle is included in the circuit, which maintains a net direct current of 0.1 A in the opposite direction.

c₂ - How long must this current be maintained to change the altitude of the orbit by 10 m.

Assume that α remains zero. Ignore all contributions from currents in the magnetosphere.

- Does the altitude decrease or increase?

Question 3. The rotating neutron star.

A 'millisecond pulsar' is a source of radiation in the universe that emits very short pulses with a period of one to several milliseconds. This radiation is in the radio range of wavelengths; and a suitable radio receiver can be used to detect the separate pulses and thereby to measure the period with great accuracy.

These radio pulses originate from the surface of a particular sort of star, the so-called neutron star. These stars are very compact: they have a mass of the same order of magnitude as that of the sun, but their radius is only a few tens of kilometers. They spin very quickly. Because of the fast rotation, a neutron star is slightly flattened (oblate). Assume the axial cross-section of the surface to be an ellipse with almost equal axes. Let r_p be the polar and r_e the equatorial radii; and let us define the flattening factor by:

$$\epsilon = \frac{(r_e - r_p)}{r_p}$$

Consider a neutron star with a mass of $2.0 \cdot 10^{30}$ kg,
 an average radius of $1.0 \cdot 10^4$ m,
 and a rotation period of $2.0 \cdot 10^{-2}$ s.

a - Calculate the flattening factor, given that the gravitational constant is $6.67 \cdot 10^{-11}$ N.m².kg⁻².

In the long run (over many years) the rotation of the star slows down, due to energy loss, and this leads to a decrease in the flattening. The star has however a solid crust that floats on a liquid interior. The solid crust resists a continuous adjustment to equilibrium shape. Instead, starquakes occur with sudden changes in the shape of the crust towards equilibrium. During and after such a star-quake the angular velocity is observed to change according to figure 1.

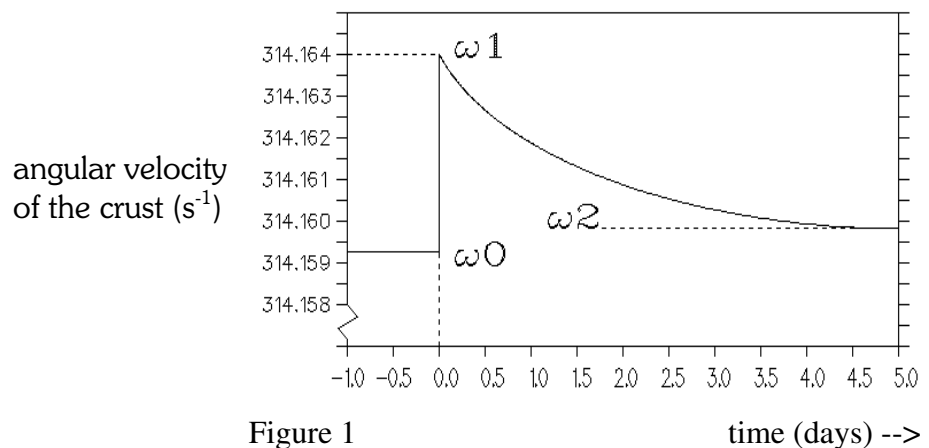

Figure 1
 A sudden change in the shape of the crust of a neutron star results in a sudden change of the angular velocity.

b - Calculate the average radius of the liquid interior, using the data of Fig. 1. Make the approximation that the densities of the crust and the interior are the same. (Ignore the change in shape of the interior).

Question 4. Determination of the efficiency of a LED.

Introduction

In this experiment we shall use two modern semiconductors: the light-emitting diode (LED) and the photo-diode (PD). In a LED, part of the electrical energy is used to excite electrons to higher energy levels. When such an excited electron falls back to a lower energy level, a photon with energy E_{photon} is emitted, where

$$E_{\text{photon}} = \frac{h \cdot c}{\lambda}$$

Here h is Planck's constant, c is the speed of light, and λ is the wavelength of the emitted light. The efficiency of the LED is defined to be the ratio between the radiated power, Φ , and the electrical power used, P_{LED} :

$$\eta = \frac{\Phi}{P_{LED}}$$

In a photo-diode, radiant energy is transformed into electrical energy. When light falls on the sensitive surface of a photo-diode, some (but not all) of the photons free some (but not all) of the electrons from the crystal structure. The ratio between the number of incoming photons per second, N_p , and the number of freed electrons per second, N_e , is called the quantum efficiency, q_p

$$q_p = \frac{N_e}{N_p}$$

The experiment

The purpose of this experiment is to determine the efficiency of a LED as a function of the current that flows through the LED. To do this, we will measure the intensity of the emitted light with a photo-diode. The LED and the PD have been mounted in two boxes, and they are connected to a circuit panel (Fig. 1). By measuring the potential difference across the LED, and across the resistors R_1 and R_3 , one can determine both the potential differences across, and the currents flowing through the LED and the PD.

We use the multimeter to measure VOLTAGES only!! This is done by turning the knob to position 'V'. The meter selects the appropriate sensitivity range automatically. If the display is not on "AUTO" switch "off" and push on "V" again. Connection: "COM" and "V- Ω ".

The box containing the photo-diode and the box containing the LED can be moved freely over the board. If both boxes are positioned opposite to each other, then the LED, the PD and the hole in the box containing the PD remain in a straight line.

Data:- The quantum efficiency of the photo-diode	$q_p = 0.88$
- The detection surface of the PD is	$2.75 \times 2.75 \text{ mm}^2$
- The wave-length of the light emitted from the LED is	635 nm.
- The internal resistance of the voltmeter is:	100 M Ω in the range up to 200 mV 10 M Ω in the other ranges.
	The range is indicated by small numbers on the display.
- Planck's constant	$h = 6.63 \cdot 10^{-34} \text{ J.s}$
- The elementary quantum of charge	$e = 1.6 \cdot 10^{-19} \text{ C}$
- The speed of light in vacuo	$c = 3.00 \cdot 10^8 \text{ m.s}^{-1}$

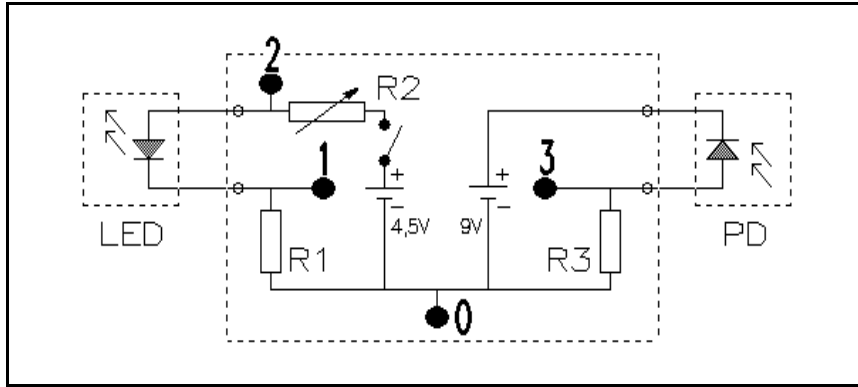

Figure 1.

$$R_1 = 100 \Omega$$

$R_2 =$ variable resistor

$$R_3 = 1 \text{ M}\Omega$$

The points labelled 0, 1, 2 and 3 are measuring points.

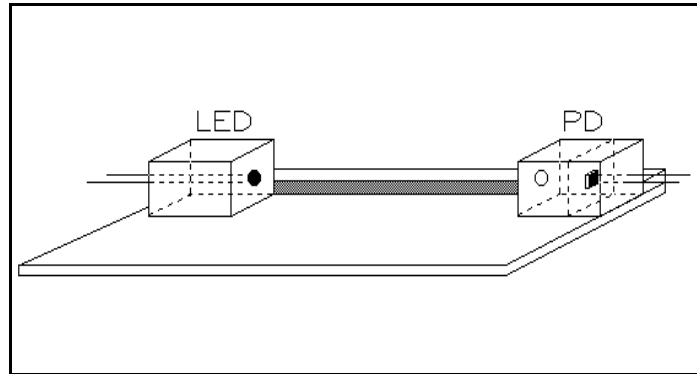

Figure 2 The experimental setup: a board and the two boxes containing the LED and the photo-diode.

Instructions

1. Before we can determine the efficiency of the LED, we must first calibrate the photo-diode. The problem is that we know nothing about the LED.

Show experimentally that the relation between the current flowing through the photo-diode and the intensity of light falling on it, I [$\text{J}\cdot\text{s}^{-1}\cdot\text{m}^{-2}$], is linear.
2. Determine the current for which the LED has maximal efficiency.
3. Carry out an experiment to measure the maximal (absolute) efficiency of the LED.

No marks (points) will be allocated for an error analysis (in THIS experiment only). Please summarize data in tables and graphs with clear indications of quantities (and units).

Question 5. Determination of the ratio of the magnetic field strengths of two different magnets.

Introduction

When a conductor moves in a magnetic field, currents are induced: these are the so-called eddy currents. As a consequence of the interaction between the magnetic field and the induced currents, the moving conductor suffers a reactive force. Thus an aluminium disk that rotates in the neighbourhood of a stationary magnet experiences a braking force.

Material available

1. A stand.
2. A clamp.
3. An homogenous aluminium disk on an axle, in a holder, that can rotate.
4. Two magnets. The geometry of each is the same (up to 1%); each consists of a clip containing two small magnets of identical magnetization and area, the whole producing a homogenous field, B_1 or B_2 .
5. Two weights. One weight has twice the mass (up to 1%) of the other.
6. A stop-watch.
7. A ruler.

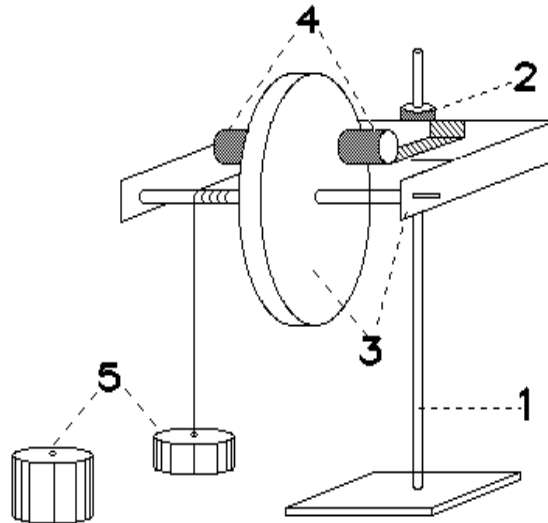

Figure 1.

The experiment

The aluminium disk is fixed to an axle, around which a cord is wrapped. A weight hangs from the cord; and when the weight is released, the disk accelerates until a constant angular velocity is reached. The terminal speed depends, among other things, on the magnitude of the magnetic field strength of the magnet.

Two magnets of different field strengths B_1 or B_2 , are available. Either can be fitted on to the holder that carries the aluminium disk: they may be interchanged.

Instructions

1. Think of an experiment in which the ratio of the magnetic field strengths B_1 and B_2 , of the two magnets can be measured as accurately as possible.
2. Give a - short - theoretical treatment, indicating how one can obtain the ratio from the measurements.
3. Carry out the experiment and determine the ratio.
4. GIVE AN ERROR ESTIMATION.

Use of the stopwatch

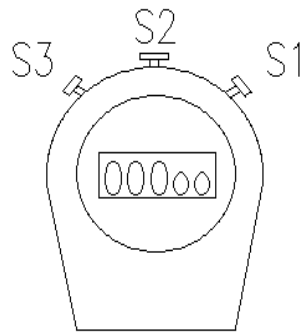

Figure 2.

The stop-watch has three buttons: S_1 , S_2 and S_3 (see Fig. 2).

Button S_2 toggles between the date-time and the stop-watch modes. Switch to the stop-watch mode. One should see this:

00000

On pressing S_1 once, the stop-watch begins timing. To stop it, press S_1 a second time.

The stop-watch can be reset to zero by pressing S_3 once.

Solution of question 1.

- a - Consider first the x-direction. If waves coming from neighbouring slits (with separation d_1) traverse paths of lengths that differ by:

$$\Delta_1 = n_1 \cdot \lambda$$

where n_1 is an integer, then a principal maximum occurs. The position on the screen (in the x-direction) is:

$$x_{n_1} = \frac{n_1 \cdot \lambda \cdot L}{d_1}$$

since $d_1 \ll d_2$.

The path difference between the middle slit and one of the slits at the edge is then:

$$\Delta_{\left(\frac{N_1}{2}\right)} = \frac{N_1}{2} \cdot n_1 \cdot \lambda$$

If on the other hand this path difference is:

$$\Delta_{\left(\frac{N_1}{2}\right)} = \frac{N_1}{2} \cdot n_1 \cdot \lambda + \frac{\lambda}{2}$$

then the first minimum, next to the principal maximum, occurs. The position of this minimum on the screen is given by:

$$x_{n_1} + \Delta x = \frac{\left(\frac{N_1}{2} \cdot n_1 \cdot \lambda + \frac{\lambda}{2}\right) \cdot L}{\frac{N_1}{2} \cdot d_1} = \frac{n_1 \cdot \lambda \cdot L}{d_1} + \frac{\lambda \cdot L}{N_1 \cdot d_1}$$

$$\rightarrow \Delta x = \frac{\lambda \cdot L}{N_1 \cdot d_1}$$

The width of the principal maximum is accordingly:

$$2 \cdot \Delta x = 2 \cdot \frac{\lambda \cdot L}{N_1 \cdot d_1}$$

A similar treatment can be made for the y-direction, in which there are N_2 slits with separation d_2 . The positions and widths of the principal maximal are:

$$(x_{n_1}, y_{n_2}) = \left(\frac{n_1 \cdot \lambda \cdot L}{d_1}, \frac{n_2 \cdot \lambda \cdot L}{d_2}\right)$$

$$2 \cdot \Delta x = 2 \cdot \frac{\lambda \cdot L}{N_1 \cdot d_1} ; \quad 2 \cdot \Delta y = 2 \cdot \frac{\lambda \cdot L}{N_2 \cdot d_2}$$

An alternative method of solution is to calculate the intensity for the 2-dimensional grid as a function of the angle that the beam makes with the screen.

- b - In the x-direction the beam 'sees' a grid with spacing a , so that in this direction we have:

$$x_{n_1} = \frac{n_1 \cdot \lambda \cdot L}{a} \quad \Delta x = 2 \cdot \frac{\lambda \cdot L}{N_0 \cdot a}$$

In the y-direction, the beam 'sees' a grid with effective spacing $a \cdot \cos(\Theta)$. Analogously, we obtain:

$$y_{n_2} = \frac{n_2 \cdot \lambda \cdot L}{a \cdot \cos(\Theta)} \quad \Delta y = 2 \cdot \frac{\lambda \cdot L}{N_0 \cdot a \cdot \cos(\Theta)}$$

In the z-direction, the beam 'sees' a grid with effective spacing $a \cdot \sin(\Theta)$. This gives rise to principal maxima with position and width:

$$y'_{n_3} = \frac{n_3 \cdot \lambda \cdot L}{a \cdot \sin(\Theta)} \quad \Delta y' = 2 \cdot \frac{\lambda \cdot L}{N_1 \cdot a \cdot \sin(\Theta)}$$

This pattern is superimposed on the previous one. Since $\sin(\Theta)$ is very small, only the zeroth-order pattern will be seen, and it is very broad, since $N_1 \cdot \sin(\Theta) \ll N_0$. The diffraction pattern from a plane wave falling on a thin plate of a cubic crystal, at a small angle of incidence to the normal, will be almost identical to that from a two-dimensional grid.

- c - In Bragg reflection, the path difference for constructive interference between neighbouring planes:

$$\Delta = 2 \cdot a \cdot \sin(\phi) \approx 2 \cdot a \cdot \phi = n \cdot \lambda \quad \rightarrow \quad \frac{x}{L} \approx 2 \cdot \phi \approx \frac{n \cdot \lambda}{a} \quad \rightarrow \quad x \approx \frac{n \cdot \lambda \cdot L}{a}$$

Here ϕ is the angle of diffraction.

This is the same condition for a maximum as in section b.

- d - For the distance, $\sqrt{2} \cdot a$, between neighbouring K ions we have:

$$\text{tg}(2\phi) = \frac{x}{L} = \frac{0,053}{0,1} \approx 0,53 \quad \rightarrow \quad a = \frac{\lambda}{2 \cdot \sin(\phi)} \approx \frac{0,15 \cdot 10^{-9}}{2 \cdot 0,24} \approx 0,31 \text{ nm}$$

$$K-K \approx \sqrt{2} \cdot 0,31 \approx 0,44 \text{ nm}$$

Marking Breakdown

- | | | |
|---|------------------------------|----|
| a | position of principal maxima | :1 |
| | width of principal maxima | :3 |
| b | lattice constants | :1 |
| | effect of thickness | :2 |
| c | Bragg reflection | :2 |
| d | Calculation of K-K spacing | :1 |

Solution of question 2.

a_1 - Since $m_2 \ll m_1$, the Atlantis travels around the earth with a constant speed. The motion of the satellite is composed of the circular motion of the Atlantis about the earth and (possibly) a circular motion of the satellite about the Atlantis.

For m_1 we have:

$$m_1 \cdot \Omega^2 \cdot R = \frac{G \cdot m_1 \cdot m_a}{R^2} \rightarrow \Omega^2 = \frac{G \cdot m_a}{R^3}$$

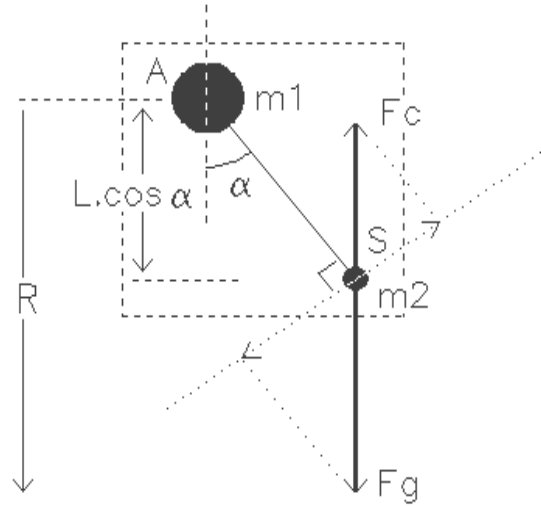

For m_2 we have:

$$m_2 \cdot L \cdot \ddot{\alpha} = -(F_g - F_c) \cdot \sin(\alpha) = -\left(\frac{G \cdot m_2 \cdot m_a}{(R - L \cdot \cos(\alpha))^2} - m_2 \cdot \Omega^2 \cdot (R - L \cdot \cos(\alpha)) \right) \cdot \sin(\alpha)$$

Using the approximation:

$$\frac{1}{(R - L \cdot \cos(\alpha))^2} \approx \frac{1}{R^2} + \frac{2 \cdot L \cdot \cos(\alpha)}{R^3}$$

and equation (1), one finds:

$$L \cdot \ddot{\alpha} = -\left(\frac{G \cdot m_a}{R^2} + \frac{2 \cdot G \cdot m_a}{R^3} \cdot L \cdot \cos(\alpha) - \frac{G \cdot m_a}{R^3} \cdot R + \frac{G \cdot m_a}{R^3} \cdot L \cdot \cos(\alpha) \right) \cdot \sin(\alpha)$$

so:

$$\ddot{\alpha} + 3 \cdot \Omega^2 \cdot \sin(\alpha) \cdot \cos(\alpha) = 0 \quad (2)$$

If α is constant: $\ddot{\alpha} = 0 \rightarrow \sin(\alpha) = 0 \rightarrow \alpha = 0; \alpha = \pi$
 $\rightarrow \cos(\alpha) = 0 \rightarrow \alpha = \pi/2; \alpha = 3\pi/2$

a₂ - The situation is stable if the moment $M = m_2 L \ddot{\alpha} L = m_2 L^2 \ddot{\alpha}$ changes sign in a manner opposed to that in which the sign of $\alpha - \alpha_0$ changes:

sign($\alpha - \alpha_0$)	-	+	-	+	-	+	-	+	-	+
α	0	$\pi/2$	π	$3\pi/2$	2π					
sign(M)	+	-	-	+	+	-	-	+	+	-
α	0	$\pi/2$	π	$3\pi/2$	2π					

The equilibrium about the angles 0 en π is thus stable, whereas that around $\pi/2$ and $3\pi/2$ is unstable.

b - For small values of α equation (2) becomes:

$$\ddot{\alpha} + 3\Omega^2 \alpha = 0$$

This is the equation of a simple harmonic motion.

The square of the angular frequency is:

$$\omega^2 = 3\Omega^2$$

so:

$$\omega = \Omega \sqrt{3} \quad \rightarrow \quad T_1 = \frac{2\pi}{\omega} = \frac{1}{3} \sqrt{3} \left(\frac{2\pi}{\Omega} \right) \approx 0,58 T_0$$

c₁ - According to Lenz's law, there will be a current from the satellite (S) towards the shuttle (A).

c₂ - For the total energy of the system we have:

$$U = U_{kin} + U_{pot} = \frac{1}{2} m \Omega^2 R^2 - \frac{G m m_a}{R} = -\frac{1}{2} \frac{G m m_a}{R}$$

A small change in the radius of the orbit corresponds to a change in the energy of:

$$\Delta U = \frac{1}{2} \frac{G m m_a}{R^2} \Delta R = \frac{1}{2} m \Omega^2 R \Delta R$$

In the situation under c₁ energy is absorbed from the system as a consequence of which the radius of the orbit will decrease.

Is a current source inside the shuttle included in the circuit, which maintains a net current in the opposite direction, energy is absorbed by the system as a consequence of which the radius of the orbit will increase.

From the assumptions in c₂ we have:

$$\Delta U = F_i v t = B I L \Omega R t = \frac{1}{2} m \Omega^2 R \Delta R \quad \rightarrow \quad t = \frac{1}{2} \frac{m \Omega \Delta R}{B I L}$$

Numerical application gives for the time: $t \approx 5,8 \cdot 10^3$ s; which is about the period of the system.

Marking breakdown:

a ₁	: 1
a ₂	: 1
b - Atlantis in uniform circular motion	: 0,5
- calculation of the period Ω	: 0,5
- equation of motion of the satellite	: 2,5
- equation of motion for small angles	: 0,5
- period of oscillations	: 1
c ₁ -	: 1
c ₂ - calculation of the time the current has to be maintained	: 1,5
- increase or decrease of the radius of the orbit	: 0,5

Solution of question 3.

a - 1st method

For equilibrium we have $F_c = F_g + N$
 where N is normal to the surface.

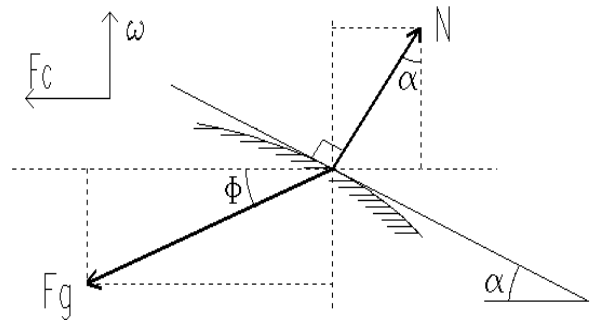

Resolving into horizontal and vertical components, we find:

$$F_g \cdot \cos(\phi) = F_c + N \cdot \sin(\alpha)$$

$$F_g \cdot \sin(\phi) = N \cdot \cos(\alpha) \quad \rightarrow \quad F_g \cdot \cos(\phi) = F_c + F_g \cdot \sin(\phi) \cdot \text{tg}(\alpha)$$

From:

$$F_g = \frac{G \cdot M}{r^2}, \quad F_c = \omega^2 \cdot r, \quad x = r \cdot \cos(\phi), \quad y = r \cdot \sin(\phi) \quad \text{en} \quad \text{tg}(\alpha) = \frac{dy}{dx}$$

we find:

$$y \cdot dy + \left(1 - \frac{\omega^2 \cdot r^3}{G \cdot M} \right) \cdot x \cdot dx = 0$$

where:

$$\frac{\omega^2 \cdot r^3}{G \cdot M} \approx 7 \cdot 10^{-4}$$

This means that, although r depends on x and y, the change in the factor in front of xdx is so slight that we can take it to be constant. The solution of Eq. (1) is then an ellipse:

$$\frac{x^2}{r_e^2} + \frac{y^2}{r_p^2} = 1 \rightarrow \frac{r_p}{r_e} = \sqrt{1 - \frac{\omega^2 \cdot r^3}{G \cdot M}} \approx 1 - \frac{\omega^2 \cdot r^3}{2 \cdot G \cdot M}$$

and from this it follows that:

$$\epsilon = \frac{r_e - r_p}{r_e} = \frac{\omega^2 \cdot r^3}{2 \cdot G \cdot M} \approx 3,7 \cdot 10^{-4}$$

2nd method

For a point mass of 1 kg on the surface,

$$U_{pot} = -\frac{G \cdot M}{r} \quad U_{kin} = \frac{1}{2} \cdot \omega^2 \cdot r^2 \cdot \cos^2(\phi)$$

The form of the surface is such that $U_{pot} - U_{kin} = \text{constant}$. For the equator ($\Phi = 0$, $r = r_e$) and for the pole ($\Phi = \pi/2$, $r = r_p$) we have:

$$\frac{G \cdot M}{r_p} = \frac{G \cdot M}{r_e} + \frac{1}{2} \cdot \omega^2 \cdot r_e^2 \rightarrow \frac{r_e}{r_p} = 1 + \frac{\omega^2 \cdot r_e^3}{2 \cdot G \cdot M}$$

Thus:

$$\epsilon = \frac{r_e - r_p}{r_e} = \frac{1 + \frac{\omega^2 \cdot r_e^3}{2 \cdot G \cdot M} - 1}{1 + \frac{\omega^2 \cdot r_e^3}{2 \cdot G \cdot M}} \approx \frac{\omega^2 \cdot r_e^3}{2 \cdot G \cdot M} \approx 3,7 \cdot 10^{-4}$$

- b - As a consequence of the star-quake, the moment of inertia of the crust I_m decreases by ΔI_m .

From the conservation of angular momentum, we have:

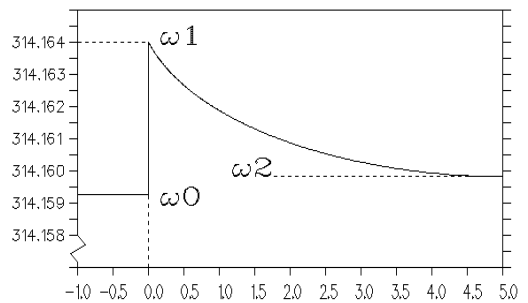

$$I_m \cdot \omega_0 = (I_m - \Delta I_m) \cdot \omega_1 \rightarrow \Delta I_m = I_m \cdot \frac{\omega_1 - \omega_0}{\omega_1}$$

After the internal friction has equalized the angular velocities of the crust and the core, we have:

$$(I_m + I_c) \cdot \omega_0 = (I_m + I_c - \Delta I_m) \cdot \omega_2 \rightarrow \Delta I_m = (I_m + I_c) \cdot \frac{\omega_2 - \omega_0}{\omega_2}$$

$$\frac{I_m}{I_m + I_c} = \frac{(\omega_2 - \omega_0) \cdot \omega_1}{(\omega_1 - \omega_0) \cdot \omega_2} \rightarrow 1 - \frac{I_c}{I_m + I_c} = \frac{(\omega_2 - \omega_0) \cdot \omega_1}{(\omega_1 - \omega_0) \cdot \omega_2}$$

$I (\cdot) R^2$

$$\rightarrow \frac{I_c}{I_m + I_c} = \frac{r_c^2}{r^2} \rightarrow \frac{r_c}{r} = \sqrt{1 - \frac{(\omega_2 - \omega_0) \cdot \omega_1}{(\omega_1 - \omega_0) \cdot \omega_2}} \approx 0.95$$

Marking breakdown

- | | | | |
|---|------------|---|------|
| a | 1st method | - expressions for the forces | :1 |
| | | - equation for the surface | :2 |
| | | - equation of ellipse | :1 |
| | | - flattening factor | :1 |
| | 2nd method | - energy equation | :4 |
| | | - flattening factor | :1 |
| b | | - conservation of angular momentum for crust | :1.5 |
| | | - conservation of angular momentum for crust and core | :1.5 |
| | | - moment of inertia for a sphere | :1 |
| | | - ratio r_c/r | :1 |

Solution of question 4.

1. The linearity of the photo-diode.

The linearity of the photo-diode can be checked by using the inverse square law between distance and intensity. Suppose that the measured distance between the LED and the (box containing the) PD is x . The intensity of the light falling on the PD satisfies:

$$I(x) = \frac{I_0}{x^2}$$

If the intensity is indeed proportional to the current flowing through the PD, it will also be proportional to the voltage, $V(x)$, measured across the resistor R_3 . From (1) it then follows that:

$$\frac{1}{\sqrt{V(x)}} \propto x$$

To obtain the correct value of $V(x)$, one should subtract from the measured voltage V_1 the voltage V_2 that one measures when the LED is turned off (but the LED box is still in place in front of the PD).

x (cm)	V_1 (V)	V_2 (V)	i_1 (μA)	i_2 (μA)	$1/[i_1(x) - i_2(x)]^{1/2}$ ($\mu\text{A}^{-1/2}$)
1.0	5.66	.003	6.23	.003	0.40
2.0	4.07	.004	4.48	.005	0.47
3.0	3.03	.005	3.33	.005	0.55
4.0	2.32	.006	2.55	.006	0.63
5.0	1.83	.006	2.01	.006	0.71
6.0	1.48	.007	1.63	.007	0.79
7.0	1.23	.007	1.35	.007	0.86
8.0	1.006	.008	1.107	.008	0.95
9.0	0.859	.009	0.945	.009	1.03
10.0	0.744	.009	0.818	.009	1.11
11.0	0.648	.010	0.713	.010	1.19
12.0	0.570	.011	0.627	.011	1.27
13.0	0.507	.012	0.558	.012	1.35
14.0	0.456	.012	0.502	.012	1.43
15.0	0.414	.013	0.455	.013	1.50
16.0	0.373	.013	0.410	.014	1.59
17.0	0.341	.014	0.375	.014	1.66
18.0	0.312	.014	0.343	.014	1.74
19.0	0.291	.015	0.320	.015	1.81
20.0	0.272	.015	0.299	.015	1.88

Plotted on a graph, one finds a perfect straight line.

2. The light intensity as a function of the electrical power of the LED

The photo-current i_{PD} is determined from the voltage V over $R_3 = 1M\Omega$. The meter itself has an internal resistance of $100 M\Omega$ in the $200 mV$ range and $10 M\Omega$ in the other ranges. We have then: $i_{PD} = 1.01 V$ resp. $i_{PD} = 1.1 V$ where V is in volts and i_{PD} in μA . The current in ampères through the LED is the voltage over R_1 in volts, divided by 100 .

----- PD -----		----- LED -----				
[x = 5 cm]						
V_1 (V)	V_2 (V)	$i_1 - i_2$ (μA)	i_{LED} (10^{-2} A)	V_{LED} (V)	P_{LED} (10^{-2} W)	$(i_1 - i_2)/P_{LED}$
1.806	.0061	1.98	2.70	1.752	4.73	0.419
1.637	.0061	1.79	2.30	1.742	4.01	0.446
1.511	.0061	1.66	2.08	1.735	3.61	0.460
1.225	.0061	1.34	1.606	1.722	2.77	0.484
1.117	.0061	1.22	1.433	1.718	2.46	0.496
0.903	.0061	0.99	1.123	1.705	1.91	0.518
0.711	.0061	0.78	0.889	1.708	1.52	0.513
0.448	.0061	0.49	0.555	1.673	0.93	0.527
0.315	.0061	0.34	0.410	1.659	0.68	0.5
0.192	.0061	0.21	0.258	1.637	0.42	0.2

The efficiency is proportional to $(i_1 - i_2)/P_{LED}$. In the graph of $(i_1 - i_2)/P_{LED}$ against i_{LED} the maximal efficiency corresponds to $i_{LED} = 0,6 \cdot 10^{-2}$ A. (See figure 2.)

3. Determination of the maximal efficiency.

The LED emits a conical beam with cylindrical symmetry. Suppose we measure the light intensity with a PD of sensitive area d^2 at a distance r_i from the axis of symmetry. Let the intensity of the light there be $\Phi(r_i)$, then we have:

$$i(r_i) = N_e \cdot e = N_f q_f e = \frac{\Phi(r_i)}{h \cdot \nu} \cdot q_f e$$

$$\Phi = \sum_i \Phi(r_i) \cdot \frac{2 \cdot \pi \cdot r_i \cdot d}{d^2} = \frac{2 \cdot \pi}{d} \cdot \sum_i \Phi(r_i) \cdot r_i = \frac{2 \cdot \pi}{d} \cdot \frac{h \cdot \nu}{q_f e} \cdot \sum_i i(r_i) \cdot r_i$$

r_i (mm)	V_1 (V)	V_2 (V)	$(i_1 - i_2) \cdot r_i$ ($\times 10^{-9}$ Am)	r_i (mm)	V_1 (V)	V_2 (V)	$(i_1 - i_2) \cdot r_i$ ($\times 10^{-9}$ Am)
0	1.833	0.006	0	39	0.097	0.006	
3	1.906	0.006	6.27	42	0.089	0.006	4.16
6	1.846	0.006	12.54	45	0.082	0.006	3.86
9	1.750	0.006	17.28	48	0.071	0.006	3.79
12	1.347	0.006	17.76	51	0.066	0.006	3.48
15	0.997	0.006	16.20	54	0.050	0.006	3.39
18	0.643	0.006	12.60	57	0.045	0.006	2.52
21	0.313	0.006	7.14	60	0.037	0.006	2.45
24	0.343	0.006	8.88	63	0.032	0.006	2.08
27	0.637	0.006	18.90	66	0.023	0.006	1.83
30	0.681	0.006	22.20	69	0.017	0.006	1.27
33	0.266	0.006	9.57	72	0.014	0.006	0.88
36	0.119	0.006	4.48	75	0.011	0.006	0.68
							0.49

The efficiency = $\Phi/P_{LED} \approx 0.001$

Marking breakdown

1 linearity of the PD

- inverse square law :1.5
- number of measuring points [1,3>; [3,5>; [5,..> :0.5/1.0/1.5
- dark current :0.5
- correct graph :1

2 determination of current at maximal efficiency

- principle :0.5
- number of measuring points [1,3>; [3,5>; [5,..> :0.5/1.0/1.5
- graph efficiency-current :0.5
- determination of current at maximal efficiency :0.5

3 determination of the maximal efficiency

- determination of the emitted light intensity :1.5
 - via estimation of the cone cross-section :0.5
 - via measurement of the intensity distribution :1.5
- determination of the maximum efficiency :1

Solution of question 5.

1. Theory	Let	- the moment of inertia of the disk be	: I
		- the mass of the weight	: m
		- the moment of the frictional force	: M_f
		- magnetic field strength	: B
		- the radius of the axle	: r
		- the moment of the magnetic force	: M_B

For the motion of the rotating disk we have:

$$I.\alpha = (m.g - m.a).r - M_f - M_B$$

We suppose that M_f is constant but not negligible. Because the disk moves in the magnetic field, eddy currents are set up in the disk. The magnitude of these currents is proportional to B and to the angular velocity. The Lorentz force as a result of the eddy currents and the magnetic field is thus proportional to the square of B and to the angular velocity, i.e.

$$M_B = c.B^2.\omega$$

Substituting this into Eq. (1), we find:

$$I.\alpha = (m.g - m.a).r - M_f - c.B^2.\omega$$

$$v_e = \left(\frac{g.r^2}{c.B^2}\right) \left(m - \frac{M_f}{g.r}\right)$$

After some time, the disk will reach its final constant angular velocity; the angular acceleration is now zero and for the final velocity v_e we find:

The final constant velocity is thus a linear function of m.

2. The experiment

The final constant speed is determined by measuring the time taken to fall the last 21 cm [this is the width of a sheet of paper].

In the first place it is necessary to check that the final speed has been reached. This is done by allowing the weight to fall over different heights. It is clear that, with the weaker magnet, the necessary height before the constant speed is attained will be larger.

Measurements for the weak magnet system:

----- time taken to fall -----

height (m)	smaller weight	larger weight
0.30	5.04 ± 0.02 (s)	2.00 ± 0.01 (s)
0.40	4.67 ± 0.04 (s)	1.71 ± 0.02 (s)
0.50	4.59 ± 0.05 (s)	1.55 ± 0.02 (s)
0.60	4.44 ± 0.06 (s)	1.48 ± 0.01 (s)
0.70	4.49 ± 0.05 (s)	1.44 ± 0.04 (s)
0.80	4.43 ± 0.03 (s)	1.38 ± 0.03 (s)
0.90	4.43 ± 0.04 (s)	1.35 ± 0.02 (s)
1.10	---	1.34 ± 0.05 (s)
1.30	---	1.33 ± 0.04 (s)

3. Final constant speed measurements for both magnet systems and for several choices of weight.

Measurements for the weak magnet:

weight	T (s)	T (s)	T (s)	T (s)	<T> (s)	<v> (m/s)
small	4.42	4.23	4.24	4.33	4.31 ± 0.09	4.9 ± 0.1
large	1.89	1.91	1.98	1.92	1.93 ± 0.04	10.9 ± 0.2
both	1.29	1.32	1.23	1.30	1.29 ± 0.04	16.3 ± 0.5

Measurements for the strong magnet:

weight	T (s)	T (s)	T (s)	T (s)	<T> (s)	<v> (m/s)
small	8.93	9.01	9.17	8.91	9.0 ± 0.1	2.33 ± 0.03
large	4.03	3.92	4.03	3.95	3.98 ± 0.06	5.28 ± 0.08
both	2.53	2.52	2.53	2.48	2.52 ± 0.03	8.3 ± 0.1

4. Discussion of the results:

- A graph between v_e and the weight should be made.
- From Eq. (2) we observe that:
 - both straight lines should intersect on the horizontal axis.
 - from the square-root of the ratio of the slopes we have immediately the ratio of the magnetic field strengths.
 - For the above measurements we find:

$$\frac{B_1}{B_2} = \sqrt{\frac{7.22}{15}} \approx 0.69 \quad \rightarrow \quad \frac{\Delta\left(\frac{B_1}{B_2}\right)}{\left(\frac{B_1}{B_2}\right)} = \frac{1}{2} \cdot \sqrt{\left(\frac{\Delta r_1}{r_1}\right)^2 + \left(\frac{\Delta r_2}{r_2}\right)^2} \approx 0.05$$

$$\frac{B_1}{B_2} = 0.69 \pm 0.03$$

Marking Breakdown

1	$M_B = c \cdot B^2 \cdot \omega$: 1
	Eq. (2)	: 1
2	Investigation of the range in which the speed is constant	: 2
3	Number of timing measurements [1,2,3,...]	: 0,1,2
	Error estimation	: 0.5
4	graph	: 0.5
	- quality	: 0.5
	- the lines intersect each other on the mass-axis	: 1
	- calculation of B_1/B_2	: 1
	- Error calculation	: 1

THEORETICAL PROBLEMS

Problem 1

The figure 1.1 shows a solid, homogeneous ball radius R . Before falling to the floor its center of mass is at rest, but the ball is spinning with angular velocity ω_0 about a horizontal axis through its center. The lowest point of the ball is at a height h above the floor.

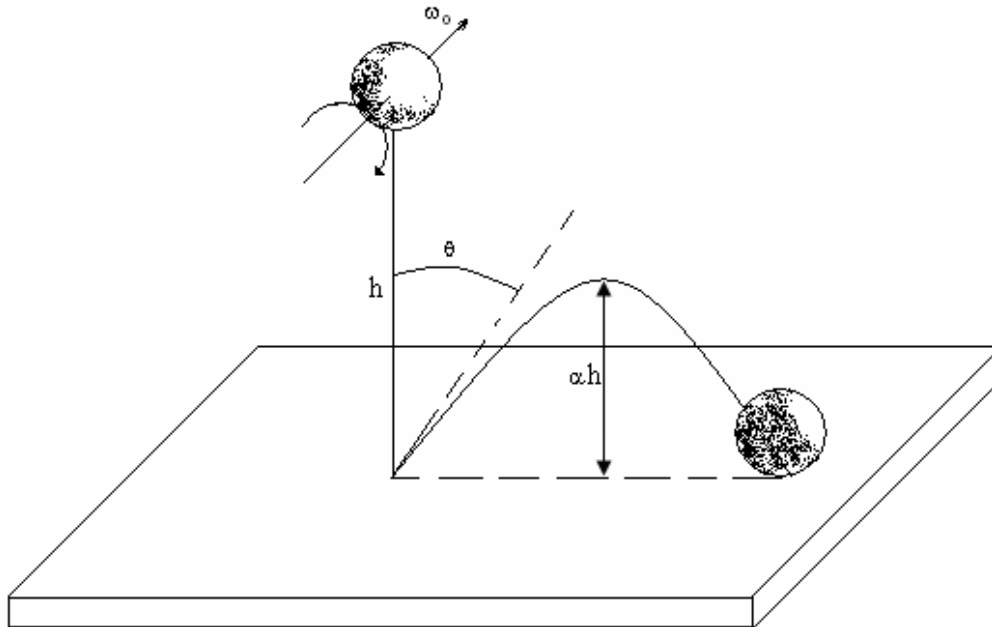

Figure 1.1

When released, the ball falls under gravity, and rebounds to a new height such that its lowest point is now αh above the floor. The deformation of the ball and the floor on impact may be considered negligible. Ignore the presence of the air. The impact time, although, is finite.

The mass of the ball is m , the acceleration due the gravity is g , the dynamic coefficient of friction between the ball and the floor is μ_k , and the moment of inertia of the ball about the given axis is:

$$I = \frac{2mR^2}{5}$$

You are required to consider two situations, in the first, the ball slips during the entire impact time, and in the second the slipping stops before the end of the impact time.

Situation I: slipping throughout the impact.

Find:

- a) $\tan \theta$, where θ is the rebound angle indicated in the diagram;
- b) the horizontal distance traveled in flight between the first and second impacts;
- c) the minimum value of ω_0 for this situations.

Situation II: slipping for part of the impacts.

Find, again:

- a) $\tan \theta$;
- b) the horizontal distance traveled in flight between the first and second impacts.

Taking both of the above situations into account, sketch the variation of $\tan \theta$ with ω_0 .

Problem 2

In a square loop with a side length L , a large number of balls of negligible radius and each with a charge q are moving at a speed u with a constant separation a between them, as seen from a frame of reference that is fixed with respect to the loop. The balls are arranged on the loop like the beads on a necklace, L being much greater than a , as indicated in the figure 2.1. The non conducting wire forming the loop has a homogeneous charge density per unit length in the in the frame of the loop. Its total charge is equal and opposite to the total charge of the balls in that frame.

Consider the situation in which the loop moves with velocity v parallel to its side AB (fig. 2.1) through a homogeneous electric field of strength E which is perpendicular to the loop velocity and makes an angle θ with the plane of the loop.

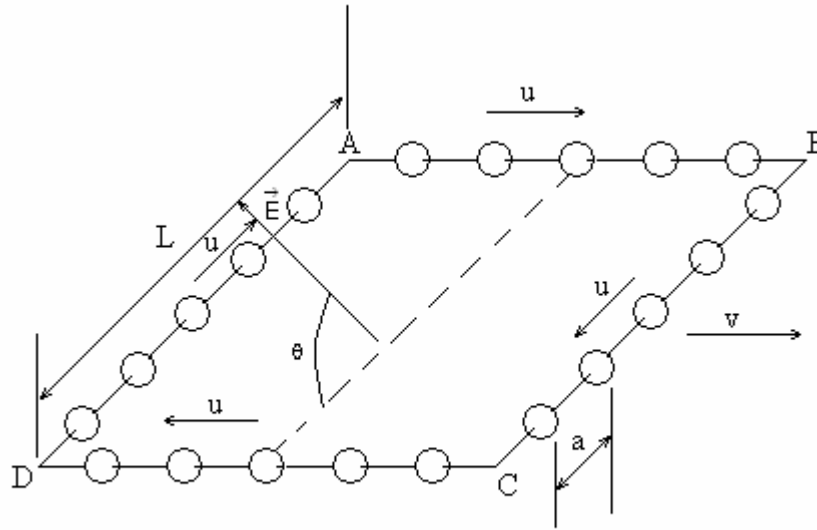

Figure 2.1

Taking into account relativistic effects, calculate the following magnitudes in the frame of reference of an observer who sees the loop moving with velocity v :

- The spacing between the balls on each of the side of the loop, a_{AB} , a_{BC} , a_{CD} , and a_{DA} .
- The value of the net charge of the loop plus balls on each of the side of the loop: Q_{AB} , Q_{BC} , Q_{CD} , and Q_{DA} .
- The modulus M of the electrically produced torque tending to rotate the system of the loop and the balls.
- The energy W due to the interaction of the system, consisting of the loop and the balls with the electric field.

All the answers should be given in terms of quantities specified in the problem.

Note. The electric charge of an isolated object is independent of the frame of reference in which the measurements takes place. Any electromagnetic radiation effects should be ignored.

Some formulae of special relativity

Consider a reference frame S' moving with velocity V with reference to another reference frame S . The axes of the frames are parallel, and their origins coincide at $t = 0$. V is directed along the positive direction of the x axis.

Relativistic sum of velocities

If a particle is moving with velocity u' in the x' direction, as measured in S' , the velocity of the particle measured in S is given by:

$$u = \frac{u' + V}{1 + \frac{u'V}{c^2}}$$

Relativistic Contraction

If an object at rest in frame S has length L_0 in the x -direction, an observer in frame S' (moving at velocity V in the x -direction) will measure its length to be:

$$L = L_0 \sqrt{1 - \frac{v^2}{c^2}}$$

Problem 3 Cooling Atoms by laser

To study the properties of isolated atoms with a high degree of precision they must be kept almost at rest for a length of time. A method has recently been developed to do this. It is called “laser cooling” and is illustrated by the problem below.

In a vacuum chamber a well collimated beam of Na^{23} atoms (coming from the evaporation of a sample at 10^3 K) is illuminated head-on with a high intensity laser beam (fig. 3.1). The frequency of laser is chosen so there will be resonant absorption of a photon by those atoms whose velocity is v_0 . When the light is absorbed, these atoms are excited to the first energy level, which has a mean value E above the ground state and uncertainty of Γ (fig. 3.2).

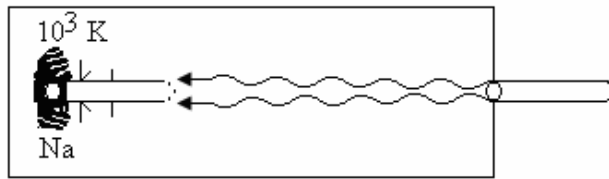

Figure 3.1

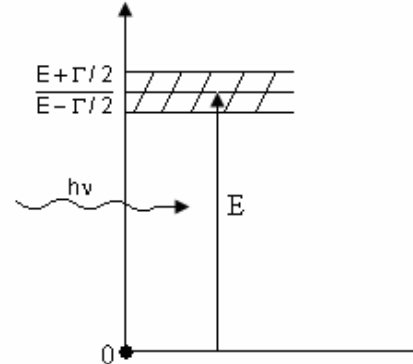

Figure 3.2

For this process, the atom's decrease in velocity Δv_1 is given by $\Delta v_1 = v_1 - v_0$. Light is then emitted by the atom as it returns to its ground state. The atom's velocity changes by $\Delta v' = v_1 - v_1$ and its direction of motion changes by an angle φ (fig. 3.3).

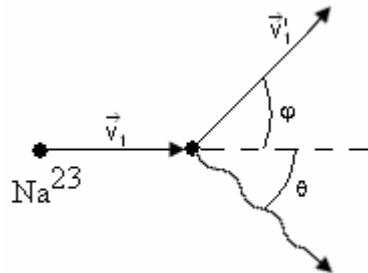

Figure 3.3

This sequence of absorption and emission takes place many times until the velocity of the atoms has decreased by a given amount Δv such that resonant absorption of light at frequency ν no longer occurs. It is then necessary to change the frequency of laser so as to maintain resonant absorption. The atoms moving at the new velocity are further slowed down until some of them have a velocity close to zero.

As first approximation we may ignore any atomic interaction processes apart from the spontaneous absorption and emission light described above.

Furthermore, we may assume the laser to be so intense that the atoms spend practically no time in the ground state.

Questions

- Find the laser frequency needed ensure the resonant absorption of the light by those atoms whose kinetic energy of the atoms inside the region behind the collimator. Also find the reduction in the velocity of these atoms, Δv_1 , after the absorption process.
- Light of the frequency calculated in question a) is absorbed by atoms which velocities lie within a range Δv_0 . Calculate this velocity range.

- c) When an atom emits light, its direction of motion changes by φ from initial direction. Calculate φ .
d) Find the maximum possible velocity decrease Δv for a given frequency.
e) What is the approximate number N of absorption-emission events necessary to reduce the velocity of an atom from its initial value v_0 -found in question a) above- almost to zero? Assume the atom travels in a straight line.
f) Find the time t that the process in question e takes. Calculate the distance ΔS an atom travels in this time.

Data

$$\begin{aligned} E &= 3,36 \cdot 10^{-19} \text{ J} \\ \Gamma &= 7,0 \cdot 10^{-27} \text{ J} \\ c &= 3 \cdot 10^8 \text{ ms}^{-1} \\ m_p &= 1,67 \cdot 10^{-27} \text{ kg} \\ h &= 6,62 \cdot 10^{-34} \text{ Js} \\ k &= 1,38 \cdot 10^{-23} \text{ JK}^{-1} \end{aligned}$$

where c is speed of light, h is Planck's constant, k is the Boltzmann constant, and m_p is the mass of proton.

THEORETICAL PROBLEMS. SOLUTIONS

Solution Problem 1

a) *Calculation of the velocity at the instant before impact*

Equating the potential gravitational energy to the kinetic energy at the instant before impact we can arrive at the pre-impact velocity v_0 :

$$mgh = \frac{mv_0^2}{2} \quad (1)$$

from which we may solve for v_0 as follows:

$$v_0 = \sqrt{2gh} \quad (2)$$

b) *Calculation of the vertical component of the velocity at the instant after impact*

Let v_{2x} and v_{2y} be the horizontal and vertical components, respectively, of the velocity of the mass center an instant after impact. The height attained in the vertical direction will be αh and then:

$$v_{2y}^2 = 2g\alpha h \quad (3)$$

from which, in terms of α (or the restitution coefficient $c = \sqrt{\alpha}$):

$$v_{2y} = \sqrt{2g\alpha h} = cv_0 \quad (4)$$

c) *General equations for the variations of linear and angular momenta in the time interval of the Impact*

Figure 1.2 shows the free body of the ball during impact

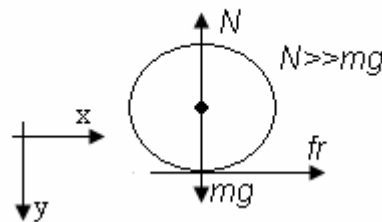

Considering that the linear impulse of the forces is equal to the variation of the linear momentum and that the angular impulse of the torques is equal to the variation of the angular momentum, we have:

$$I_y = \int_{t_1}^{t_2} N(t) dt = mv_0 + mv_{2y} = m(1+c) \sqrt{2gh} \quad (5)$$

$$I_x = \int_{t_1}^{t_2} f_r(t) dt = mv_{2x} \quad (6)$$

$$I_{\theta} = \int_{t_1}^{t_2} R f_r(t) dt = R \int_{t_1}^{t_2} f_r(t) dt = I(\omega_0 - \omega_2) \quad (7)$$

Where I_x , I_y and I_{θ} are the linear and angular impulses of the acting forces and ω_2 is the angular velocity after impact. The times t_1 and t_2 correspond to the beginning and end of impact.

Variants

At the beginning of the impact the ball will always be sliding because it has a certain angular velocity ω_0 . There are, then, two possibilities:

- I. The entire impact takes place without the friction being able to spin the ball enough for it to stop at the contact point and go into pure rolling motion.
- II. For a certain time $t \in (t_1, t_2)$, the point that comes into contact with the floor has a velocity equal to zero and from that moment the friction is zero. Let us look at each case independently.

Case I

In this variant, during the entire moment of impact, the ball is sliding and the friction relates to the normal force as:

$$f_r = \mu_k N(t) \quad (8)$$

Substituting (8) in relations (6) and (7), and using (5), we find that:

$$I_x = \mu_k \int_{t_1}^{t_2} N(t) dt = \mu_k I_y = \mu_k (1+c) \sqrt{2gh} = mv_{2x} \quad (9)$$

and:

$$I_{\theta} = R \mu_k \int_{t_1}^{t_2} N(t) dt = R \mu_k m(1+c) \sqrt{2gh} = I(\mu_0 - \mu_2) \quad (10)$$

which can give us the horizontal component of the velocity v_{2x} and the final angular velocity in the form:

$$V_{2x} = \mu_k (1+c) \sqrt{2gh} \quad (11)$$

$$\omega_2 = \omega_0 - \frac{\mu_k m R (1+c)}{I} \sqrt{2gh} \quad (12)$$

With this we have all the basic magnitudes in terms of data. The range of validity of the solution under consideration may be obtained from (11) and (12). This solution will be valid whenever at the end of the impact the contact point has a velocity in the direction of the negative x . That is, if:

$$\omega_2 R > v_{2x}$$

$$\omega_0 - \frac{\mu_k m R (1+c)}{I} \sqrt{2gh} > \frac{\mu_k (1+c)}{R} \sqrt{2gh}$$

$$\omega_0 > \frac{\mu_k \sqrt{2gh}}{R} (1+c) \left(\frac{mR^2}{I} + 1 \right) \quad (13)$$

so, for angular velocities below this value, the solution is not valid.

Case II

In this case, rolling is attained for a time t between the initial time t_1 and the final time t_2 of the impact. Then the following relationship should exist between the horizontal component of the velocity v_{2x} and the final angular velocity:

$$\omega_2 R = v_{2x} \quad (14)$$

Substituting (14) and (6) in (7), we get that:

$$mRv_{2x} = I \left(\omega_0 - \frac{v_{2x}}{R} \right) \quad (15)$$

which can be solved for the final values:

$$v_{2x} = \frac{I\omega_0}{mR + \frac{I}{R}} = \frac{I\omega_0 R}{mR^2 + I} = \frac{2}{7} \omega_0 R \quad (16)$$

and:

$$\omega_2 = \frac{I\omega_0}{mR^2 + I} = \frac{2}{7} \omega_0 \quad (17)$$

Calculation of the tangents of the angles

Case I

For $\tan \theta$ we have, from (4) and (11), that:

$$\tan \theta = \frac{v_{2x}}{v_{2y}} = \frac{\mu_k (1+c) \sqrt{2gh}}{c \sqrt{2gh}} = \mu_k \frac{(1+c)}{c}$$

$$\tan \theta = \mu_k \frac{(1+c)}{c} \quad (18)$$

i.e., the angle is independent of ω_0 .

Case II

Here (4) and (16) determine for $\tan \theta$ that:

$$\tan \theta = \frac{v_{2x}}{v_{2y}} = \frac{I\omega_0 R}{I + mR^2} \frac{1}{c \sqrt{2gh}} = \frac{I\omega_0 R}{(I + mR^2) c \sqrt{2gh}}$$

$$\tan \theta = \frac{2\omega_0 R}{7c \sqrt{2gh}} \quad (19)$$

then (18) and (19) give the solution (fig. 1.3).

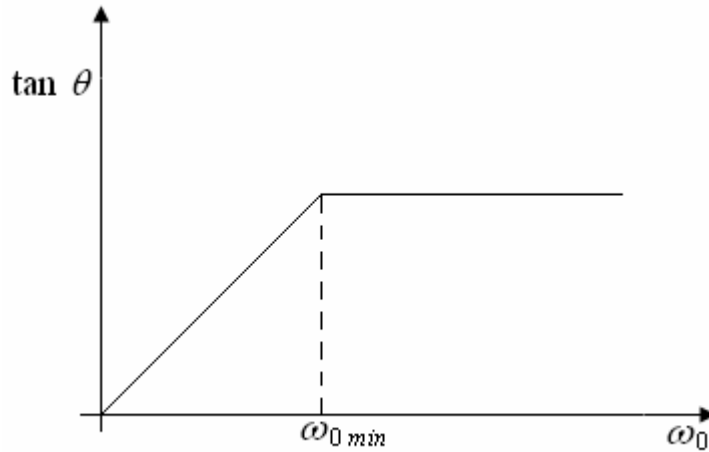

Figure 1.3

We see that θ does not depend on ω_0 if $\omega_0 > \omega_{0 \min}$; where $\omega_{0 \min}$ is given as:

$$\omega_{0 \min} = \frac{\mu_k (1+c) \sqrt{2gh} \left(1 + \frac{mR^2}{I} \right)}{R}$$

$$\omega_{o\ min} = \frac{7\mu_k(1+c)\sqrt{2gh}}{2R} \quad (20)$$

Calculation of the distance to the second point of impact

Case I

The rising and falling time of the ball is:

$$t_v = 2 \frac{v_{2y}}{g} = \frac{2c\sqrt{2gh}}{g} = 2c\sqrt{\frac{2h}{g}} \quad (21)$$

The distance to be found, then, is;

$$d_I = v_{2x}t_v = \mu_k(1+c)\sqrt{2gh}2c\sqrt{\frac{2h}{g}} \quad (22)$$

$$d_I = 4\mu_k(1+c)ch$$

which is independent of ω_0 .

Case II

In this case, the rising and falling time of the ball will be the one given in (21). Thus the distance we are trying to find may be calculated by multiplying t_v by the velocity v_{2x} so that:

$$d_{II} = v_{2x}t_v = \frac{I\omega_0}{mR^2 + I}2c\sqrt{\frac{2h}{g}} = \frac{2\omega_0 Rc}{1 + \frac{5}{2}}\sqrt{\frac{2h}{g}}$$

$$d_{II} = \frac{4}{7}c\sqrt{\frac{2h}{g}}R\omega_0$$

Thus, the distance to the second point of impact of the ball increases linearly with ω_0 .

Marking Code

The point value of each of the sections is:

- | | |
|-----|------------|
| 1.a | 2 points |
| 1.b | 1.5 points |
| 1.c | 2 points |
| 2.a | 2 points |
| 2.b | 1.5 points |
| 3 | 1 point |

Solution Problem 2

Question a:

Let's call S the lab (observer) frame of reference associated with the observer that sees the loop moving with velocity v ; S' to the loop frame of reference (the x' axis of this system will be taken in the same direction as \vec{v} ; y' in the direction of side DA and z' axis, perpendicular to the plane of the loop). The axes of S are parallel to those of S' and the origins of both systems coincide at $t = 0$.

1. Side AB

S''_{AB} will be a reference frame where the moving balls of side AB are at rest. Its axes are parallel to those of S and S' . S'' has a velocity u with respect to S' .

According to the Lorentz contraction, the distance a , between adjacent balls of AB , measured in S'' , is:

$$a_r = \frac{a}{\sqrt{1 - \frac{u^2}{c^2}}} \quad (1)$$

(This result is valid for the distance between two adjacent balls that are in one of any sides, if a is measured in the frame of reference in which they are at rest).

Due to the relativistic sum of velocities, an observer in S sees the balls moving in AB with velocity:

$$u_{AB} = \frac{v + u}{1 + \frac{uv}{c^2}} \quad (2)$$

So, because of Lorentz contraction, this observer will see the following distance between balls:

$$a_{AB} = \sqrt{1 - \frac{u_{AB}^2}{c^2}} a_r \quad (3)$$

Substituting (1) and (2) in (3)

$$a_{AB} = \sqrt{\frac{1 - \frac{v^2}{c^2}}{1 + \frac{uv}{c^2}}} a \quad (4)$$

2. Side CD

For the observer in S , the speed of balls in CD is:

$$u_{CD} = \frac{v - u}{1 - \frac{uv}{c^2}} \quad (5)$$

From the Lorentz contraction:

$$a_{CD} = \sqrt{1 - \frac{u_{CD}^2}{c^2}} a_r \quad (6)$$

Substituting (1) and (5) in (6) we obtain:

$$a_{CD} = \frac{\sqrt{1 - \frac{v^2}{c^2}}}{1 - \frac{uv}{c^2}} a \quad (7)$$

3. Side DA

In system S' , at time t'_0 , let a ball be at $x'_1 = y'_1 = z'_1 = 0$. At the same time the nearest neighbour to this ball will be in the position $x'_2 = 0, y'_2 = a, z'_2 = 0$.

The space-time coordinates of this balls, referred to system S , are given by the Lorentz transformation:

$$\begin{aligned} x &= \frac{1}{\sqrt{1 - \frac{v^2}{c^2}}} (x' + vt') \\ y &= y' \\ z &= z' \\ t &= \frac{1}{\sqrt{1 + \frac{v^2}{c^2}}} \left(t' + \frac{x'v'}{c^2} \right) \end{aligned} \quad (8)$$

Accordingly, we have for the first ball in S :

$$x_1 = \frac{1}{\sqrt{1-\frac{v^2}{c^2}}} vt'_0; y_1=0; z_1=0; t_1 = \frac{1}{\sqrt{1-\frac{v^2}{c^2}}} t'_0 \quad (9)$$

And for the second:

$$x_2 = \frac{1}{\sqrt{1-\frac{v^2}{c^2}}} vt'_0; y_2 = a; z_2 = 0; t_2 = \frac{1}{\sqrt{1-\frac{v^2}{c^2}}} t'_0 \quad (10)$$

As $t_1 = t_2$, the distance between two balls in S will be given by:

$$a_{DA} = (x_2 - x_1)^2 + (y_2 - y_1)^2 + (z_2 - z_1)^2 \quad (11)$$

So:

$$a_{AD} = a \quad (12)$$

4. Side BC

If we repeat the same procedure as above, we can obtain that:

$$a_{BC} = a \quad (13)$$

Question b:

The charge of the wire forming any of the sides, in the frame of reference associated with the loop can be calculated as:

$$Q_{\text{wire}} = -\frac{L}{a} q \quad (14)$$

Because L/a is the number of balls in that side. Due to the fact that the charge is invariant, the same charge can be measured in each side of the wire in the lab (observer) frame of reference.

1. Side AB

The charge corresponding to balls in side AB is, in the lab frame of reference:

$$Q_{\text{AB,balls}} = \frac{L\sqrt{1-\frac{v^2}{c^2}}}{a_{\text{AB}}} - q \quad (15)$$

This is obtained from the multiplication of the number of balls in that side multiplied by the (invariant) charge of one ball. The numerator of the first factor in the right side of equation (15) is the contracted distance measured by the observer and the denominator is the spacing between balls in that side.

Replacing in (15) equation (4), we obtain:

$$Q_{\text{AB,balls}} = \left(\frac{1+uv}{c^2} \right) \frac{Lq}{a} \quad (16)$$

Adding (14) and (16) we obtain for the total charge of this side:

$$Q_{\text{AB}} = \frac{uvL}{c^2} \frac{L}{a} - q \quad (17)$$

2. Side CD

Following the same procedure we have that:

$$Q_{\text{CD,balls}} = \frac{\sqrt{1-\frac{v^2}{c^2}}}{a_{\text{CD}}} - q = \left(1 - \frac{uv}{c^2} \right) \frac{Lq}{a} \quad (18)$$

And adding (14) and (18) we obtain:

$$Q_{\text{CD}} = -\frac{uvL}{c^2} \frac{L}{a} - q \quad (19)$$

The length of these sides measured by the observer in S is L and the distance between balls is a, so:

$$Q_{\text{BC,balls}} = Q_{\text{DA,balls}} = \frac{Lq}{a} \quad (20)$$

Adding (14) and (20) we obtain:

$$Q_{BC} = 0 \quad (21.1)$$

$$Q_{DA} = 0 \quad (21.2)$$

Question c:

There is electric force acting into the side AB equal to:

$$\vec{F}_{AB} = Q_{AB} \vec{E} = \left(\frac{uv}{c^2}\right) \frac{L}{a} q \vec{E} \quad (22)$$

and the electric force acting into the side CD is:

$$\vec{F}_{CD} = Q_{CD} \vec{E} = -\left(\frac{uv}{c^2}\right) \frac{L}{a} q \vec{E} \quad (23)$$

F_{CD} and F_{AB} form a force pair. So, from the expression for the torque for a force pair we have that (fig. 2.2):

$$M = \left| \vec{F}_{AB} \right| L \sin \theta \quad (24)$$

And finally:

$$M = \frac{uv L^2}{c^2 a} |q| |\vec{E}| \sin \theta \quad (25)$$

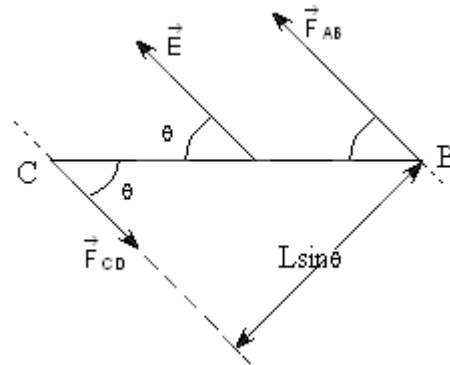

Fig 2.2

Question d:

Let's call V_{AB} and V_{CD} the electrostatic in the points of sides AB and CD respectively. Then:

$$W = V_{AB} Q_{AB} + V_{CD} Q_{CD} \quad (26)$$

Let's fix zero potential ($V=0$) in a plane perpendicular to \vec{E} and in an arbitrary distance R from side AB (fig. 2.3).

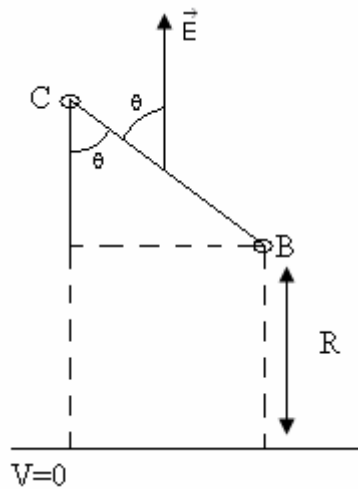

Figure 2.3

Then:

$$W = -ERQ_{AB} - E(R + L \cos \theta) Q_{CD} \quad (27)$$

But $Q_{CD} = -Q_{AB}$, so:

$$W = -ELQ_{AB} \cos \theta \quad (28)$$

Substituting (17) in (28) we obtain:

$$W = \frac{uvL^2qE}{c^2a} \cos \theta \quad (29)$$

Marking Code

Grading for questions will be as follows:

- a) 4,5 points.
- b) 2,0 points.
- c) 1,5 points.
- d) 2,0 points.

These points are distributed in questions in the following way:

Question a:

1. Obtaining expressions (4) and (7) correctly: 3,0 points.
Only one of them correct: 2,0 points.
2. Obtaining expressions (12) and (13) correctly including the necessary calculations to arrive to this results: 1,5 points.
Only one of them correct: 1,0 points.

If the necessary calculations are not present: 0,8 point for both (12) and (13) correct; 0,5 points for only one of them correct.

Question b:

1. Obtaining expressions (17) and (19) correctly: 1,0 point.
Only one of them correct: 1,0 point.
2. Obtaining expressions (21.1) and (21.2) correctly: 0,5 point.
Only one them correct: 0,5 point.

Question d:

1. Obtaining expression (29) correctly: 2,0 points.

When the modulus of a vector is not present where necessary, the student will loose 0,2 points. When the modulus of q is not present where necessary the student will loose 0,1 points.

Solution Problem 3

Question a:

The velocity v_o of the atoms whose kinetic energy is the mean of the atoms on issuing from the collimator is given is given by:

$$\frac{1}{2}mv_o^2 = \frac{3}{2}kT \Rightarrow v_o = \sqrt{\frac{3kT}{m}} \quad (1)$$

$$v_o = \sqrt{\frac{3 \cdot 1,38 \cdot 10^{-23} \cdot 10^3}{23 \cdot 1,67 \cdot 10^{-27}}} \text{ m/s}$$

$v_o \approx 1,04 \cdot 10^3$ m/s because:

$$m \approx 23 m_p \quad (2)$$

Since this velocity is much smaller than c , $v_o \ll c$, we may disregard relativistic effects.

Light is made up of photons with energy $h\nu$ and momentum $h\nu/c$.

In the reference system of the laboratory, the energy and momentum conservation laws applied to the absorption process imply that:

$$\frac{1}{2}mv_o^2 + h\nu = \frac{1}{2}mv_1^2 + E; mv_o - \frac{h\nu}{c} = mv_1 \Rightarrow \Delta v_1 = v_1 - v_o = \frac{-h\nu}{mc}$$

$$\frac{1}{2}m(v_1^2 - v_o^2) = h\nu - E \Rightarrow \frac{1}{2}m(v_1 + v_o)(v_1 - v_o) = h\nu - E$$

$h\nu/c \ll mv_o$. Then $v_1 \approx v_o$ and this implies $mv_o \Delta v_1 = h\nu - E$, where we assume that

$$v_1 + v_o \approx 2v_o$$

Combining these expressions:

$$v = \frac{\frac{E}{h}}{1 + \frac{v_o}{c}} \quad (3)$$

and:

$$\Delta v_1 = -\frac{E}{mc} \frac{1}{1 + \frac{v_o}{c}} \quad (4)$$

And substituting the numerical values:

$$v \approx 5,0 \cdot 10^{14} \text{ Hz} \quad \Delta v_1 \approx -3,0 \cdot 10^{-2} \text{ m/s}$$

If we had analyzed the problem in the reference system that moves with regard to the laboratory at a velocity v_o , we would have that:

$$\frac{1}{2} m(v_1 - v_2)^2 + E = hv$$

Where $v = \frac{v'}{1 + \frac{v_o}{c}}$ is the frequency of the photons in the laboratory

system. Disregarding Δv_1^2 we get the same two equations above.

The approximations are justifiable because:

$$-\frac{|\Delta v_1|}{v_o} \sim 10^{-4}$$

Then $v_1 + v_o = 2v_o - \Delta v_1 \approx 2v_o$

Question b:

For a fixed v :

$$v_o = c \left(\frac{E}{hv} - 1 \right) \quad (5)$$

if E has an uncertainty Γ , v_o would have an uncertainty:

$$\Delta v_o = \frac{c\Gamma}{hv} = \frac{c\Gamma \left(1 + \frac{v_o}{c} \right)}{E} \approx \frac{c\Gamma}{E} = 6,25 \text{ m/s} \quad (6)$$

so the photons are absorbed by the atoms which velocities are in the interval

$$\left(v_o - \frac{\Delta v_o}{2}, v_o + \frac{\Delta v_o}{2} \right)$$

Question c:

The energy and momentum conservation laws imply that:

$$\frac{1}{2} m v_1^2 + E = \frac{1}{2} m v_1'^2 + hv'$$

(v' – is the frequency of emitted photon)

$$m v_1 = m v_1' \cos \varphi + \frac{h v'}{c} \cos \theta$$

$$0 = m v_1' \sin \varphi - \frac{h v'}{c} \sin \theta$$

The deviation φ of the atom will be greatest when $\theta = \frac{\pi}{2}$, then:

$$mv_1 = mv'_1 \cos \varphi_m; \frac{hv'}{c} = mv'_1 \sin \varphi_m \Rightarrow \tan \varphi_m = \frac{hv'}{mv_1 c}$$

since $v' \approx v$:

$$\tan \varphi_m \approx \frac{E}{mv_1 c} \quad (7)$$

$$\varphi_m = \arctg \frac{E}{m v c} \Rightarrow \varphi_m \approx 5 \cdot 10^{-5} \text{ rad} \quad (8)$$

Question d:

As the velocity of the atoms decreases, the frequency needed for resonant absorption increases according to:

$$v = \frac{\frac{E}{h}}{1 + \frac{v_o}{c}}$$

When the velocity is $v_o = \Delta v$, absorption will still be possible in the lower part of the level if:

$$hv = \frac{E - \frac{\Gamma}{2}}{1 + \frac{v_o - \Delta v}{c}} = \frac{E}{1 + \frac{v_o}{c}} \Rightarrow \Delta v = \frac{c\Gamma}{2E} \left(1 + \frac{v_o}{c} \right) \quad (9)$$

$$\Delta v = 3,12 \text{ m/s}$$

Question e:

If each absorption-emission event varies the velocity as $\Delta v_1 \approx \frac{E}{mc}$, decreasing velocity from v_o to almost zero would require N events, where:

$$N = \frac{v_o}{|\Delta v_1|} \approx \frac{m c v_o}{E} \Rightarrow N \approx 3,56 \cdot 10^4$$

Question f:

If absorption is instantaneous, the elapsed time is determined by the spontaneous emission. The atom remains in the excited state for a certain time, $\tau = \frac{h}{\Gamma}$, then:

$$\Delta t = N\tau = \frac{Nh}{\Gamma} = \frac{m c h v_o}{\Gamma E} \Rightarrow \Delta t \approx 3,37 \cdot 10^{-9} \text{ s}$$

The distance covered in that time is $\Delta S = v_o \Delta t / 2$. Assuming that the motion is uniformly slowed down:

$$\Delta S = \frac{1}{2} m c h v_o^2 \Gamma E \Rightarrow \Delta S \approx 1,75 \text{ m}$$

Marking Code

a) Finding	v_o	1 pt	Total 3 pt
“	v	1 pt	
“	Δv_1	1 pt	
b) “	Δv_o	1,5 pt	Total 1,5 pt

c)	“	Φ_m	1,5 pt	Total 1,5 pt
d)	“	Δv	1 pt	Total 1 pt
e)	“	N	1 pt	Total 1 pt
f)	“	Δt	1 pt	Total 2 pt
	“	ΔS	1 pt	

Overall total 10 pts

We suggest in all cases: 0,75 for the formula; 0,25 for the numeral operations.

E X P E R I M E N T A L P R O B L E M

Problem

Inside a black box provided with three terminals labeled A, B and C, there are three electric components of different nature. The components could be any of the following types: batteries, resistors larger than 100 ohm, capacitors larger than 1 microfarad and semiconductor diodes.

- a) Determine what types of components are inside the black box and its relative position to terminal A, B and C. Draw the exploring circuits used in the determination, including those used to discard circuits with similar behaviour
- b) If a battery was present, determine its electromotive force. Draw the experimental circuit used.
- c) If a resistor was present, determine its value. Draw the experimental circuit used.
- d) If a capacitor was present, determine its value. Draw the experimental circuit used.
- e) If a diode was present, determine V_o and V_r , where V_o the forward bias threshold voltage and V_r is the reverse bias breakdown voltage.
- f) Estimate, for each measured value, the error limits.

The following equipments and devices are available for your use:

- 1 back box with three terminals labeled A, B and C;
- 1 variable DC power supply;
- 2 Polytest 1 W multimeters;
- 10 connection cables;
- 2 patching boards;
- 1 100 k Ω , 5 % value resistor;
- 1 10 k Ω , 5 % value resistor;
- 1 1 k Ω , 5 % value resistor;
- 1 100 μ F, 20 % value capacitor;
- 1 chronometer;
- 2 paper sheets;
- 1 square ruler;
- 1 interruptor.

Voltmeter internal resistance.

Scale	Value in k Ω	
0-1 V	3,2	1 %
0-3 V	10	1 %
0-10 V	32	1 %
0-20 V	64	1 %
0-60 V	200	1 %

Ammeter internal resistance.

Scale	Value in Ω	
0-0,3 mA	1 000	1 %
0-1 mA	263	1 %
0-3 mA	94	1 %
0-20 mA	30,4	1 %
0-30 mA	9,84	1 %
0-100 mA	3,09	1 %
0-300 mA	0,99	1 %
0-1 mA	0,31	1 %

Notice: Do not use the Polystes 1 W as an ohmmeter. Protect your circuit against large currents, and do not use currents larger than 20 mA.

Give your results by means of tables or plots.

When drawing the circuits, use the following symbols:

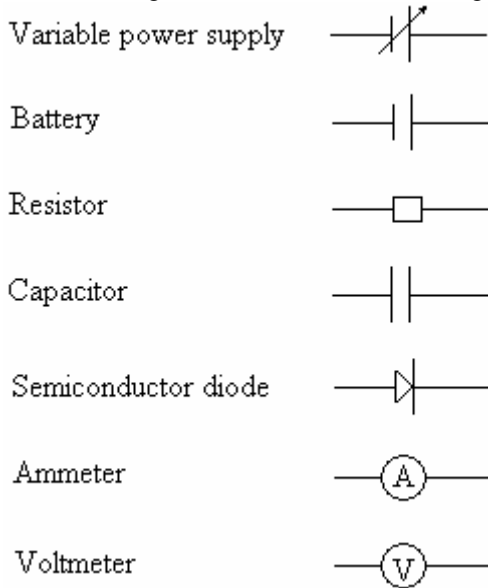

EXPERIMENTAL PROBLEM. SOLUTION

Solution Problem

Since a battery could be present, the first test should be intended to detect it. To do that, the voltage drops V_{ab} , V_{ac} and V_{bc} should be measured using a voltmeter. This test will show that no batteries are present.

Next, a testing circuit as shown in figure 4.1 should be used.

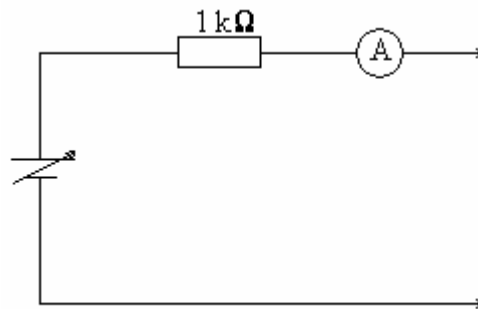

Figure 4.1

By means of this circuit, the electric conduction between a pair of terminals should be tested, marking all permutations and reversing the polarity. Resistor R_1 is included to prevent a large current across the diode. One conclusion is that between A and C there is a diode and a resistor in series, although its current position is still unknown. The other conclusion is that a capacitor is tighted to terminal B. To determine the actual circuit topology, further transient experiments have to be conducted.

In this way, it is concluded that the actual circuit inside the black box is that shown in figure 4.2.

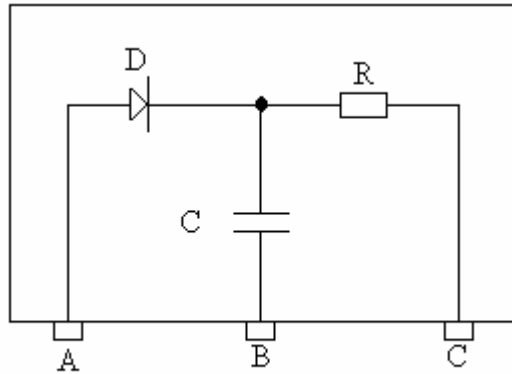

Figure 4.2

The best procedure for the resistor value determination is to plot a set of voltage and current values measured between A and C. Figure 4.3 shows the resulting plot. Extrapolating both linear regions, the values of V_0 and V_z are obtained and the resistor value equals the reciprocal of the slope.

Similar, the best method to measure the capacitor value is to build a testing circuit as shown in figure 4.4. The current is adjusted to full scale and then, the switch is opened.

The time needed by the current to drop to its half value is measured. Applying the formulae $t = RC \ln(2)$, the value of C is obtained.

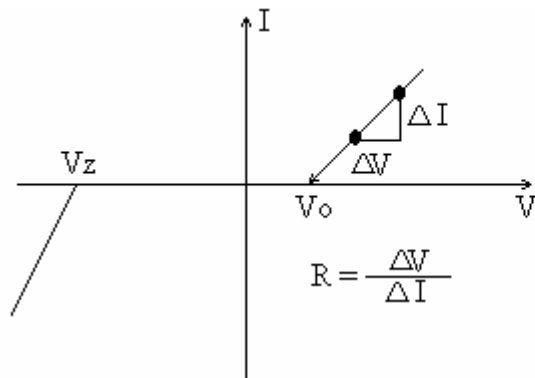

Figure 4.3

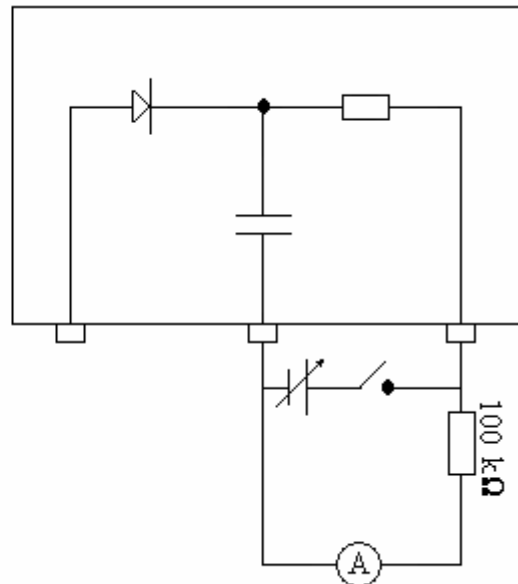

Figure 4.4

Marking Code

1. Determination of circuit topology: 8 points.
 - 1.1 For discarding the presence of a battery: 1 point.
 - 1.2 For drawing the exploring circuit which determine the circuit topology in a unique way: 7 points.
2. Resistor and diode parameters value measurement: 8 points.
 - 2.1 For drawing the measuring circuit: 2 points.
 - 2.2 Error limits calculation: 3 points.
 - 2.3 Result: 3 points.
 - 2.3.1 Coarse method: 2 points.
 - 2.3.2 Graphic method: 3 points.
3. Capacitor value measurement: 4 points.
 - 3.1 For drawing the measuring circuit: 2 points.
 - 3.2 Error limits calculations: 2 points.

PROBLEM 1: A ROTATING SATELLITE.

The figure shows a satellite which is circling the Earth in an approximately circular orbit in the Earth's equatorial plane. The satellite consists of a massless central body P and four small peripheral bodies B. The four bodies B each have mass m ; they are fastened to P by means of long thin wires of length r that do not stretch. All these five bodies, P and the four bodies B, are coplanar with the equatorial plane, and they can rotate within this plane. The four radial wires are linked to each other by further thin wires which keep the angles between the radial wires constant at 90° .

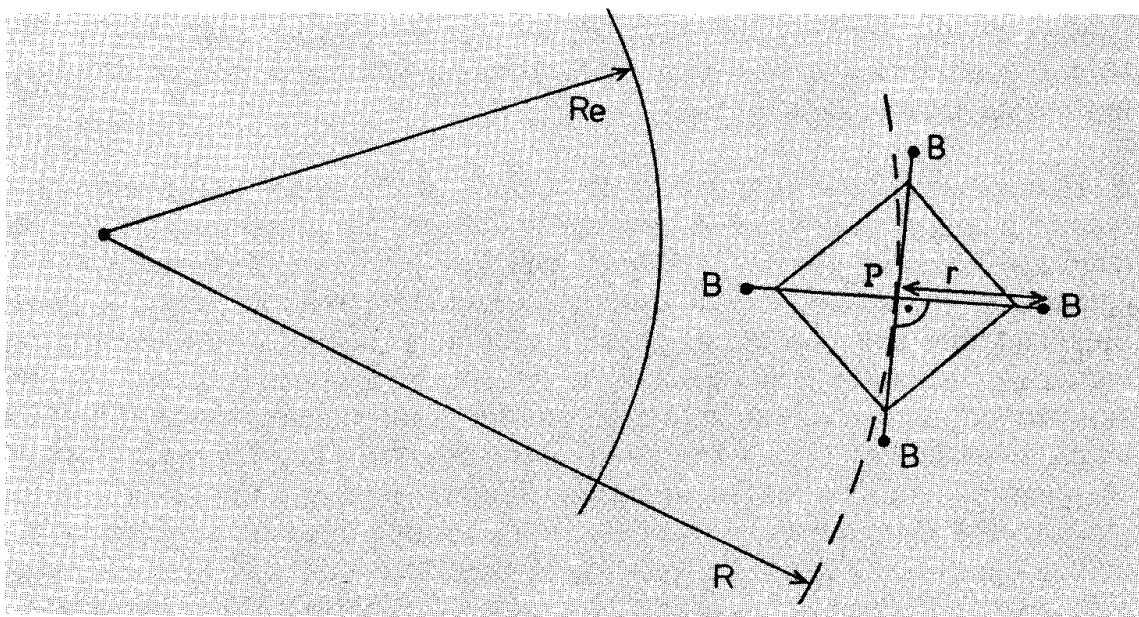

The link wires are included in the system in order to prevent oscillatory movement of the individual bodies B which would otherwise make the analysis of the movements extremely complicated. All the bodies B rotate around P at the same angular velocity, which is ω with respect to the fixed stars. Thus, the satellite behaves as a rigid body.

Analyze the following questions for the general case, considering all possible situations, including both senses of rotation of the bodies B. Also obtain numerical values for certain of the quantities found in questions (1) and (2)—the quantities required and the necessary numerical data are listed at the end of the problem.

- 1) The drawing shows the satellite in the position where for the various wires, r is parallel, anti-parallel or perpendicular to \mathbf{R} . (The vector \mathbf{r} runs from body P to a body B and has length r ; the vector \mathbf{R} runs from the centre of mass of the Earth to the body P.)

Determine the force exerted by a radial wire on one of the bodies B in each of these four positions. These positions correspond approximately to the maximum and minimum forces.

- 2) Inside the four bodies B there are four identical machines, powered by solar energy, connected to the radial wires. Each machine pulls the wire in, towards B, for a short time whenever there is near maximum force in the wire (as indicated in the previous question), and lets the same length of wire out again when the tension is at a minimum. The length of wire that is pulled in and let out is 1% of the mean length of the radial wire. The mean length does not change with time.

What is the net power converted by one machine, averaged over one rotation of the satellite?

The net power is defined as $\frac{W_1 - W_2}{T}$, where W_1 is the work that the machine performs on the wire when pulling it in, W_2 is the work that the wire performs on the machine when it is reeled out and T is the period of rotation.

- 3) Discuss the changes in the motion of the satellite that are caused by the action of the machines. In particular, analyze any changes that may occur in each of the situations listed in the table overleaf.

Fill in the table with your results and comments, and don't forget to hand it in.

Data:

Numerical answers are required in the following situation:

The radius of the orbit of the central body is given by $R = R_E + 500$ km.

The mean length of the radial wires is $r = 100$ km.

Thus the diameter of the satellite system is 200 km.

The bodies B have masses $m = 1000$ kg.

Initially the four bodies B rotate, as referred to the stars, around the central body P at 10 revolutions/hour.

The masses of the wires are negligible, and the central body P is massless.

Advice:

Consider both senses of rotation for ω .

Exact solutions are not expected. Results with 5% accuracy are fully acceptable.

Ignore the gravitational effect of the moon and the sun.

Useful data:

Mass of Earth	$M_E = 5.97 \times 10^{24}$ kg
Gravitational constant	$G = 6.673 \times 10^{-11}$ m ³ kg ⁻¹ s ⁻²
Radius of Earth at equator	$R_E = 6378$ km
Denote the product $M_E G$ by K .	$K = 3.983 \times 10^{14}$ m ³ s ⁻²

Country code:

ANSWER TABLE

Fill in this table as part of your answer. Write down equalities or inequalities and/or short explanations where necessary.

The quantity indicated below ...	increases if ...	decreases if ...	stays unchanged if ...	stays unchanged in all situations.
orbital velocity of the satellite				Yes <input type="checkbox"/> No <input type="checkbox"/>
radius R of the orbit of the satellite				Yes <input type="checkbox"/> No <input type="checkbox"/>
angular velocity ω of the satellite				Yes <input type="checkbox"/> No <input type="checkbox"/>
gravitational potential energy of the satellite				Yes <input type="checkbox"/> No <input type="checkbox"/>
<p>Could the satellite reach a higher orbit as a result of the work done by the machines?</p> <p style="text-align: center;">Yes <input type="checkbox"/> No <input type="checkbox"/></p>				
<p>Could the satellite reach an arbitrarily high orbit, practically leaving the gravitational influence of Earth? Why?</p> <p>Answer:</p>				

SOLUTION : PROBLEM 1

Notation. Vectors are denoted as \vec{r} , \vec{R} . Without vector symbol, r and R mean the lengths of these vectors.

Unit vectors of specified direction are indicated by indicating the direction vector in brackets: $\vec{e}(\vec{R})$ is a vector of unit length, directed from the centre of earth to point P. The vector pointing from B to the centre of earth is $-\vec{e}(\vec{R} + \vec{r})$ and $\vec{a} = -\vec{e}(\vec{R})K/R^2 = -K\vec{R}/R^3$ represents the gravitational acceleration at \vec{R} .

Different cases are denoted as follows: in the first section, the word *parallel* means that \vec{R} and \vec{r} are parallel, i.e. that the periferal body B is highest up in its orbit. In the same way, *antiparallel* means the position of B nearest to the earth. In later sections, the different senses of rotation of the satellite are denoted as *parallel* and *antiparallel*: When the angular velocity vectors $\vec{\omega}$ and $\vec{\Omega}$ (the angular velocity of P with respect to the centre of the earth) are parallel, it means that the satellite rotates in the direction of its orbital motion.

Determination of the tensional forces

Determination of the tensional forces requires certain approximations to be done:

1. The centre of the satellite is on a circular Kepler orbit, i.e.

$$\Omega^2 R = K/R^2.$$

The problem formulation indicates that the initial orbit is intended to be circular. Physically, the orbit could also be elliptical.

2. ω and Ω are constant.

3. $r \ll R$ so that higher powers of r/R can be neglected.

4. As shown in Figure 1, the extreme end of each radial wire of the satellite is free to swing back and forth according to the resultant acceleration of the body B. The force acting on a body B is generally not directed towards the centre P of the satellite. However, the end section of the wire between P and B is directed along the direction of the force. It is assumed that these free end sections are so short that their swinging doesn't affect significantly the motion of the bodies B of the satellite, i.e. that $\vec{\omega}$ and \vec{r} are valid for describing the motion of B around P.

5. The side position was defined in the problem as the position where \vec{r} and \vec{R} are perpendicular. The distance between this point and the centre of the earth is $\sqrt{r^2 + R^2} = R\sqrt{1 + (r^2/R^2)} \approx 1.00011 R \approx R + 0.008r$. Thus a good approximation for the side position is the point whose distance to the centre of earth equals R . We can equally well estimate the force for this approximate side point, the error of approximation will certainly be less than 5 %.

None of the assumptions 1, 2, 3, and 5 holds if r , the radius of the satellite, is thousands of kilometers and if the satellite is near the earth. With the numerical values given in the problem, $r/R \approx 0.0145$ so that the approximations are better than the expected accuracy of solution. Rigorous proof of these approximations

PROBLEM 1: A ROTATING SATELLITE.

might be more demanding than solving the problem itself. It was not expected from the competitors and it will not be given here.

The vectors \vec{r} and \vec{R} , and the angular velocities $\vec{\omega}$ and $\vec{\Omega}$ are defined with respect to an inertial (non-rotating) frame of reference.

The location vector for one body B is $\vec{R} + \vec{r}$. Thus we get for the velocity and acceleration of B

$$\vec{v} = \vec{\Omega} \times \vec{R} + \vec{\omega} \times \vec{r}, \quad (1)$$

$$\vec{a} = -\Omega^2 \vec{R} - \omega^2 \vec{r} \quad (2)$$

With less formalism: the motion of a body B is a superposition (or sum) of two circular motions, one around the earth and the other around the centre of the satellite. Thus also the acceleration of B is the sum of the two accelerations: one directed towards the centre of earth, and of magnitude $\Omega^2 R$, and the other directed towards the centre of the satellite, and of magnitude $\omega^2 r$.

The gravitational force acting on the body B depends on the distance of B from the centre of earth, i.e. on the length of the sum of vectors $\vec{R} + \vec{r}$:

$$F_{gravity} = m \frac{K}{|\vec{R} + \vec{r}|^2}. \quad (3)$$

and is directed towards the centre of earth, i.e. the direction is opposite to the sum of vectors $\vec{R} + \vec{r}$. In vector notation this can be written as

$$\vec{F}_{gravity} = -m \frac{K \vec{e}(\vec{R} + \vec{r})}{|\vec{R} + \vec{r}|^2} \quad (4)$$

$$= -m \frac{K(\vec{R} + \vec{r})}{|\vec{R} + \vec{r}|^3}. \quad (5)$$

Quite often, the second form is simpler in computations.

The total force acting on B corresponds to the acceleration:

$$\vec{F} = \vec{F}_{wire} + \vec{F}_{gravity} \quad (6)$$

$$= m\vec{a} = m(-\Omega^2 \vec{R} - \omega^2 \vec{r}) \quad (7)$$

This gives the tensional force:

$$\vec{F}_{wire}/m = -\Omega^2 \vec{R} - \omega^2 \vec{r} + \frac{K(\vec{R} + \vec{r})}{|\vec{R} + \vec{r}|^3}. \quad (8)$$

This is an exact result. Numerical answers can be calculated with this expression. One example is given in the section for numerical results. However, a better understanding is possible if we find an approximation so that such higher order terms are neglected which don't have a significant influence on the results. Indicate the

SOLUTION : PROBLEM 1

position of the body B by defining the distance of B from the centre of earth as $|\vec{R} + \vec{r}| = R + \rho$ where $-r \leq \rho \leq r$. Express the denominator in powers of ρ/R :

$$(R + \rho)^{-3} = R^{-3}(1 - 3\rho/R + O(r/R)^2) \quad (9)$$

Physically this approximation means that the change of gravitational acceleration is assumed to be linearly proportional to ρ , the change of radius. Substituting this approximation in the expression of \vec{F}_{wire} gives the tensional force in arbitrary rotational position of the satellite as

$$\vec{F}_{wire}/m = -\Omega^2 \vec{R} - \omega^2 \vec{r} + \frac{(\vec{R} + \vec{r})(1 - 3\rho/R + O(r/R)^2)}{R} \frac{K}{R^2} \quad (10)$$

$$= -\Omega^2 \vec{R} - \omega^2 \vec{r} + \Omega^2 R \left(\vec{R}/R + \vec{r}/R - 3\rho \vec{R}/R^2 + \vec{R}O(r/R)^2 \right) \quad (11)$$

$$\approx -\omega^2 \vec{r} + \Omega^2 \vec{r} - 3\Omega^2 \rho \frac{\vec{R}}{R} \quad (12)$$

Analyze the contribution of the last term in the positions up (\vec{r} and \vec{R} parallel), down (\vec{r} and \vec{R} antiparallel), and sideways (instead of the exact definition, use the approximate definition which corresponds to the value $\rho = 0$):

Up, $\rho = +r$: $\vec{R} = \vec{r} \frac{R}{r}$, giving $\rho \vec{R} = r \vec{R} = r \vec{r} \frac{R}{r} = \vec{r} R$.

The last term equals $-3\Omega^2 \vec{r}$.

Down, $\rho = -r$: $\vec{R} = -\vec{r} \frac{R}{r}$, giving $\rho \vec{R} = -r \vec{R} = -r(-\vec{r} \frac{R}{r}) = \vec{r} R$.

Again, the last term equals $-3\Omega^2 \vec{r}$.

Sideways, $\rho = 0$: The last term is zero.

Substituting for the last term gives the force in the three different cases:

$$\vec{F}_{min} = -(\omega^2 - \Omega^2) \vec{r} m \quad \text{if } \rho = 0 \quad (13)$$

$$\vec{F}_{max} = -(\omega^2 + 2\Omega^2) \vec{r} m \quad \text{if } \rho = \pm r \quad (14)$$

$$\Delta F = F_{max} - F_{min} = 3\Omega^2 r m \quad (15)$$

In all three cases the force is parallel or antiparallel to the direction of vector \vec{r} . The expression $(\omega^2 + 2\Omega^2)$ is always positive. Thus \vec{F}_{max} is always directed to the direction of $-\vec{r}$, i.e. the wire is pulling the body B at 'up' and 'down' positions. However, the expression $(\omega^2 - \Omega^2)$ becomes negative if $\omega < \Omega$. This would mean that \vec{F}_{min} is directed parallel to \vec{r} , i.e. that the wire is pushing the body B. This is impossible, however: it would cause the collapse of the satellite because the structure consisting of thin wires can only withstand pulling forces. Thus we must require $\omega > \Omega$ in the following analysis. The expression given for ΔF is based on this assumption.

PROBLEM 1: A ROTATING SATELLITE.

Work done by the machines

The maximum force affecting any selected body B is present when B is in 'up' position and when B is in 'down' position, i.e. twice during one revolution of the satellite with respect to the vertical axis. Similarly the minimum force is present twice during one relative revolution, in the 'left' and 'right' side positions. The vertical direction rotates with the angular velocity Ω of the orbital motion. If the satellite rotates in the direction of its orbital motion ($\vec{\omega}$ and $\vec{\Omega}$ are parallel) then the satellite must rotate slightly more than one full revolution in order to make one revolution with respect to the vertical axis. Then the angular velocity of the satellite with respect to the vertical axis is $\omega - \Omega$. In the other case (satellite rotates in the direction opposite to the direction of orbital motion) the angular velocity of the satellite with respect to the vertical axis is $\omega + \Omega$: less than one absolute revolution is needed for one relative revolution. In vector notation both cases are given by the expression $\vec{\omega} - \vec{\Omega}$.

The machines perform two work cycles (one cycle: pulling the wire + releasing it) during one relative revolution. Thus the work per one relative revolution is

$$\Delta E = 2 \Delta r (F_{max} - F_{min}) = 6 m \Delta r r \Omega^2 = 0.06 m r^2 \Omega^2$$

The period of one relative revolution is

$$\Delta T = 2\pi / (\omega \pm \Omega)$$

where plus sign corresponds to the antiparallel case. The mean power is given by

$$P = \Delta E / \Delta T = 2 \Delta r (F_{max} - F_{min}) / (2\pi / (\omega \pm \Omega)) = \Delta r (F_{max} - F_{min}) (\omega \pm \Omega) / \pi$$

Numerical results

From $K/R^2 = \Omega^2 R$ one gets $KR = 25.4 \cdot 10^{20} m^4 s^{-2}$ and

$\Omega = \sqrt{(KR^{-3})} = 0.001106 \text{ rad/s}$. The orbital period is 5678 s.

The angular velocity of the satellite is $\omega = 2\pi/360s = 0.01745 \text{ rad/s}$.

The relative angular velocities are

$\omega - \Omega = 0.01634 \text{ rad/s}$ (parallel case) and

$\omega + \Omega = 0.01856 \text{ rad/s}$ (antiparallel case).

$$F_{min} = (\omega^2 - \Omega^2) rm = 100km \cdot 1000kg \cdot 303.08 \cdot 10^{-6} s^{-2} = 30339 \text{ N} \quad (16)$$

$$F_{max} = (\omega^2 + 2\Omega^2) rm = 100km \cdot 1000kg \cdot 307.68 \cdot 10^{-6} s^{-2} = 30706 \text{ N} \quad (17)$$

$$F_{max} - F_{min} = 3 r m \Omega^2 = 367 \text{ N}. \quad (18)$$

$$P = \Delta r (F_{max} - F_{min}) (\omega \pm \Omega) / \pi, \quad (19)$$

$$P_{antiparallel} = 1 \text{ km} \cdot 367 \text{ N} \cdot 0.01856 \text{ rad/s} \cdot \pi^{-1} = 2168 \text{ W}. \quad (20)$$

$$P_{parallel} = 1 \text{ km} \cdot 367 \text{ N} \cdot 0.01634 \text{ rad/s} \cdot \pi^{-1} = 1909 \text{ W}. \quad (21)$$

SOLUTION : PROBLEM 1

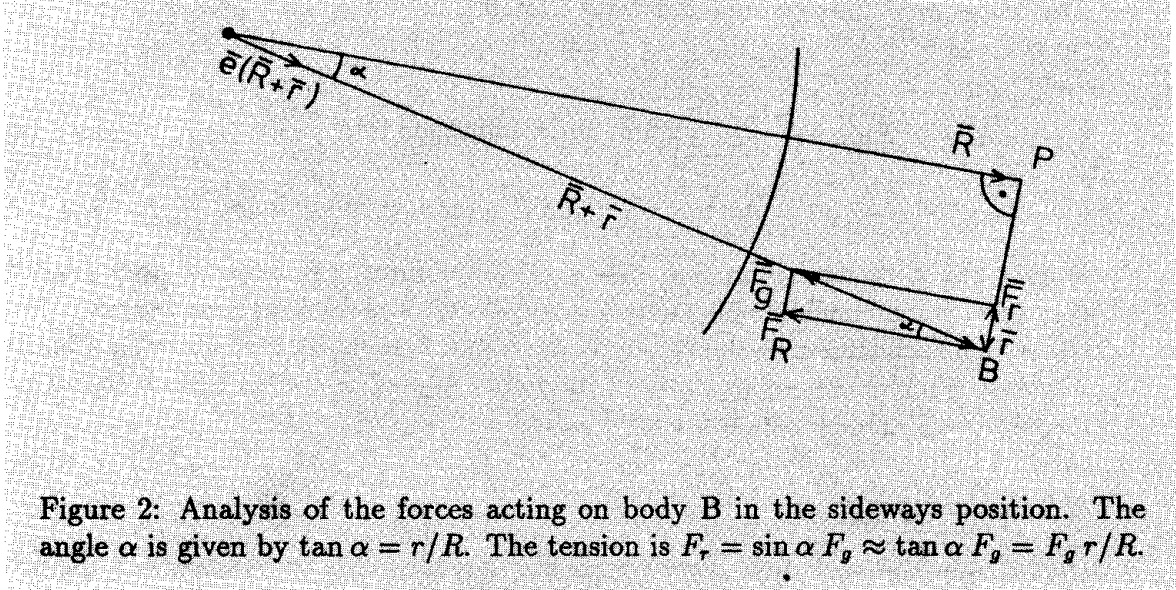

Figure 2: Analysis of the forces acting on body B in the sideways position. The angle α is given by $\tan \alpha = r/R$. The tension is $F_\tau = \sin \alpha F_g \approx \tan \alpha F_g = F_g r/R$.

These values should be reported rounded to two significant figures because approximations have been used:

$$P_{\text{antiparallel}} = 2200 \text{ W}, \quad (22)$$

$$P_{\text{parallel}} = 1900 \text{ W}. \quad (23)$$

Example of the exact expression. As an example, we evaluate here the force for the exact side position directly from the expression

$$\vec{F}_{\text{wire}}/m = -\Omega^2 \vec{R} - \omega^2 \vec{r} + \frac{K (\vec{R} + \vec{r})}{|\vec{R} + \vec{r}|^3} \quad (24)$$

$$= -\Omega^2 \vec{R} - \omega^2 \vec{r} + \frac{K \vec{e}(\vec{R} + \vec{r})}{|\vec{R} + \vec{r}|^2}. \quad (25)$$

Taking into account the Kepler equation and the radius value for the side point, we get

$$\vec{F}_{\text{wire}}/m = -\Omega^2 \vec{R} - \omega^2 \vec{r} + \frac{K}{1.00011^2 R^2} \vec{e}(\vec{R} + \vec{r}) \quad (26)$$

$$= -\Omega^2 \vec{R} - \omega^2 \vec{r} + 0.99979 \Omega^2 R \vec{e}(\vec{R} + \vec{r}) \quad (27)$$

Now the unit vector $\vec{e}(\vec{R} + \vec{r})$ must be expressed with the vectors \vec{R} and \vec{r} :

$$\vec{e}(\vec{R} + \vec{r}) = \frac{\vec{R} + \vec{r}}{|\vec{R} + \vec{r}|} = 0.99989 \left(\frac{\vec{R}}{R} + \frac{\vec{r}}{R} \right).$$

PROBLEM **1**: A ROTATING SATELLITE.

The same result may be obtained from a triangular construction, see Figure 2. Thus we get

$$\vec{F}_{wire}/m = -\Omega^2 \vec{R} - \omega^2 \vec{r} + 0.99968 \Omega^2 R \left(\frac{\vec{R}}{R} + \frac{\vec{r}}{R} \right) \quad (28)$$

$$= -0.00032 \Omega^2 \vec{R} - (\omega^2 - 0.99968 \Omega^2) \vec{r}. \quad (29)$$

Within the numerical accuracy, this is an exact result. It is easily seen that the first term can be neglected because it is small and also because it represents a force which is perpendicular to the radial wire. In fact, it could be used for estimating the direction of the free-swinging end of the radial wire. The second term is practically identical with our earlier result for F_{min} .

Change of orbit

In principle, the work done by the machines in the satellite could transform the orbit into a non-circular shape. In this problem, however, it is given that the machines work four times during *each* rotational cycle of the satellite. Thus the effect of the machines is distributed more or less symmetrically all around the orbit. Because of the circular symmetry, we may safely assume that the orbit stays circular even while the machines are operating. Thus the change of orbit, as caused by the action of the machines, is from one circular Kepler orbit to another circular Kepler orbit. It would be possible to analyze the change of orbit by analyzing the resultant of the gravitational forces which are acting on the four bodies B. This is, however, a difficult and laborious route. Full analysis of the situation is extremely difficult by that route. However, that might be the only possible method for analyzing how an intermittent use of the machines leads to an elliptic Kepler orbit. But in the present case it is not needed. Conservation laws are the all-important technique for analyzing many physical situations, and if it is possible to identify a sufficient number of conserved quantities, the problem can be transformed to solving the conservation equations. When rotational motion is considered, typical conserved quantities are: energy and angular momentum. The difficulty is often how to define the system correctly so that it includes all the energies which together are conserved, or all the angular momenta. First consider the angular momentum. As is explained elsewhere, the angular momentum of the rotational motion of the satellite need not be conserved. However, the total angular momentum I_{tot} of the satellite with respect to the centre of earth is conserved because the only external forces acting on the satellite are gravitational and directed towards the centre of earth. (This would not be true if the satellite were in a polar orbit and the non-spherical shape of the earth were considered). The I_{tot} consists of two parts: the internal angular momentum, due to the rotation of the satellite, and the orbital angular momentum, due to the motion of the centre-of-mass of the satellite around the earth.

Another conserved quantity is the energy. To be more precise, the total energy E_{tot} of the satellite is increased by the net work done by the machines. The following terms are included in E_{tot} :

SOLUTION : PROBLEM 1

- The rotational energy of the satellite, $1/2 4m \omega^2 r^2$
- The orbital kinetic energy of the satellite, i.e. the kinetic energy of the motion of the centre-of-mass, $1/2 4m \Omega^2 R^2$
- The potential energy of the satellite in the gravitational field of earth, $-4mK/R$. In the first order approximation which we are using, this can be calculated as if the total mass of the satellite were concentrated in the centre point P.

Thus we have for the total energy the equation

$$E_{tot} = 4m(-K/R + 1/2 \Omega^2 R^2 + 1/2 \omega^2 r^2) \quad (30)$$

$$= 2m(-\Omega^2 R^2 + \omega^2 r^2) \quad (\text{because of Kepler}). \quad (31)$$

A third equation for solving the system is obtained from the Kepler law, connecting the radius of orbit and the orbital velocity of the satellite. Thus we have the system of three equations

$$\frac{K}{R^2} = \Omega^2 R \quad (\text{Kepler law}) \quad (32)$$

$$I_{tot} = 4m(\omega r^2 \pm \Omega R^2) = \text{Constant} \quad (33)$$

$$E_2 - E_1 = E_m, \quad (34)$$

where E_1 and E_2 are the total energies before and after the machines have done the net work E_m . The upper sign corresponds to the *parallel case*: the satellite rotates in the sense of the orbital motion, and the lower sign to the *antiparallel case*: the senses of the rotations are opposite.

These three independent equations are sufficient for solving the three unknowns Ω , R , and ω . As such, the equations do not give a clear picture of the change. The total angular momentum depends on three variables which all can vary when the orbit changes. Analysis of equations is best started by solving the orbital angular momentum as a function of R from the Kepler equation:

$$I_{orbit} = 4m\Omega R^2 = 4m\sqrt{\Omega^2 R^4} = 4m\sqrt{KR}.$$

This shows that the orbital angular momentum increases whenever R increases. Also, this gives for the total angular momentum the equation

$$I_{tot} = 4m(\omega r^2 \pm \sqrt{(KR)}) = \text{Const}.$$

Because r and K are constants, this equation defines a connection between ω and R .

- Parallel case: if the satellite rotates faster, i.e. ω increases, then R must decrease in order that I_{tot} be conserved. And if ω decreases, R must increase.

PROBLEM 1: A ROTATING SATELLITE.

- Antiparallel case: if the satellite rotates faster, i.e. ω increases, then R must increase in order that I_{tot} be conserved. Similarly, if ω decreases in the antiparallel case, then R also must decrease.

Intuitively one would expect that the increase of the total energy of the satellite (because of the positive work done by the machines) would lead to increase of ω , then the whole problem would be fully analyzed. However, it is necessary to analyze the energy equations in order to make certain that this really is true. The orbital energy as a function of R is

$$E_{orbit}/4m = -K/R + 1/2 \Omega^2 R^2 = -1/2 K/R,$$

and the total energy:

$$E_{total}/2m = -K/R + \omega^2 r^2.$$

As shown above, in the antiparallel case the conservation of angular momentum requires that ω and R either both increase or both decrease. The first alternative is valid because then both terms of the total energy expression increase which correctly corresponds to the increase of total energy.

The parallel case requires a more detailed analysis. We form the differential change of I_{tot} :

$$d\omega r^2 + 1/2 K (KR)^{-1/2} dR = 0.$$

This is substituted in the expression of total energy,

$$dE_{total}/2m = d(-K/R + \omega^2 r^2) \tag{35}$$

$$= K/R^2 dR + 2\omega d\omega r^2 \tag{36}$$

$$= K/R^2 dR - 2\omega 1/2 K (KR)^{-1/2} dR \tag{37}$$

$$= K dR (1/R^2 - \omega (KR)^{-1/2}) \tag{38}$$

$$= K dR (1/R^2 - \omega/(\Omega R^2)) \tag{39}$$

$$= K dR R^{-2}(1 - \omega/\Omega) \tag{40}$$

Because $\omega > \Omega$, an increase of total energy corresponds to a decrease of R and further to an increase of ω . This confirms that ω is increasing in both cases, as intuitively expected.

Answers to the tabulated questions.

The radius R decreases in the parallel case and increases in the antiparallel case.

The change of the orbital velocity is opposite to the change of R : increase in the parallel and decrease in the antiparallel case.

The angular velocity ω increases.

The potential energy increases with increasing R , thus increasing in the antiparallel and decreasing in the parallel case.

As seen from earlier answers, it is possible that the satellite gets in a higher orbit.

SOLUTION : PROBLEM 1

It happens in the antiparallel case.

The last question was not quite clear. It was hoped that this question might bring forward the contrast with ordinary rocket propulsion: it is possible for a rocket to practically leave the gravitational field of earth by using a *finite* amount of energy. However, a rotating satellite would need an infinite amount of energy if R grows without limit: The equation for I_{tot} shows that ω must increase without limit, proportional to the square root of the radius of orbit. Tensional forces in the satellite would then also increase without limit, proportional to the radius R . Thus there would be a maximum value for R , corresponding to the strength of the radial wires. With larger values of R , the wires would break. Rather few participants were able to analyze this aspect of the problem.

In a few answers, the last question was seen in a different perspective. When the Kepler equation is taken into account, the work per one revolution can be written as

$$\Delta E = 2 \int dr (F_{max} - F_{min}) = 6 m \int dr r \Omega^2 = 6K m \int dr r R^{-3}$$

showing that the mean power decreases proportionally to $R^{-2.5}$. Thus the increase of R gets slower and slower when time goes on. Strictly speaking, this alone would not prevent R from reaching any predetermined value, given enough time.

Grading

The credit points for this problem were split to two parts of five points each:

- Correct results for the forces 'up' and 'down' were given one and half points. Another 1.5 points were given for the correct force in the 'sideways' position. Small numerical errors were forgiven. If there was an essential error in the equations, then no credit was given for such a result.
- Two points were given if the mean power was correctly obtained as based on the results of the first part. This merit was given even if the forces were wrong. This part of the problem was very easy. (In fact, it was difficult enough because of the need to use the relative angular velocity, but this was only recognized after the competition.)
- The second half of points were given for the analysis of the changes of orbit. One point was given for the answer which correctly related changes in the orbital velocity and radius R , although it did not help in understanding the mechanism of orbit change. Half a point was given for each one of the conservation equations of energy and angular momentum even if there was no further analysis of the situation. One point was given if the conservation equations were correctly analyzed for one rotational sense, and another point if the other rotational sense was also covered. No credit was given for a few correct stray answers in the table if they did not reflect an understanding of the situation.

PROBLEM 1: A ROTATING SATELLITE.

- One point was given for the last question of the table, concerning the ability of the satellite to leave the gravitational field of earth.

Remarks

1. **Coriolis force?** There was a difficulty in this problem which luckily was not affecting the competitors. When the problem was scrutinized, several people thought that it would be necessary to include the Coriolis term in the solution of the problem. Of course, it would be possible to use a rotating coordinate system. Either, one could use a system which rotates with Ω , so that one coordinate axis points 'down', towards centre of earth. Or, one could use a system which rotates with the satellite, with angular velocity ω , so that the bodies B of the satellite would be in fixed positions in this coordinate system. But both cases generate unnecessary complications without any useful simplifications. There are no relative movements which would need to be defined with respect to a rotating frame of reference.

The only thing that is relative to another coordinate system is the relative angular velocity of the satellite with respect to the vertical axis (needed for the computation of the mean power). It is obtained simply as a sum or difference of the angular velocities ω and Ω .

Thus it is better to work in one inertial coordinate system. Only a few of the competitors used or attempted to use Coriolis formalism!

2. **The reason for varying forces.** The vector presentation which we used for the solution does not explain the 'reason' for the variation of tension: The extra tension in up and down positions is caused by the variation of the gravitational force as a function of radius: higher up, the pull of earth is less, thus more tension is needed for keeping the body in orbit. And deeper down, the gravitational pull is stronger, needing more tension for supporting the body. The smaller tension in the side positions is explained by the direction of the gravitational pull: there is an angle between the pull directions at the centre of the satellite and at the body B. The whole phenomenon is well known as *the tide*: the gravitational forces of the sun and the moon create a change of apparent gravity on earth which is exactly the same phenomenon as the varying tensional forces of our rotational satellite.

3. **Consistency check.** The resultant of the calculated four forces acting on the four bodies B is zero (the opposing forces are of same magnitude but point in opposite directions). This is correct, it is consistent with the assumption that the central structures (wires and centre point) of the satellite are massless.

If the analysis were carried out to second order, then the resultant would not be zero, which would indicate a contradiction. This means that the original assumptions (centre point of satellite on circular Kepler orbit, constant ω and Ω) would need to be revised in second order calculations. It would turn out that the centre point oscillates around the circular orbit with a frequency $2(\omega \pm \Omega)/\pi$.

SOLUTION : PROBLEM 1

4. Difficulty of the problem. From the outset it was estimated that this is a difficult problem. However, the problem turned out to be even more difficult than we estimated. Only about 10 % of participants were able to analyze the change of orbit. One detail of the solution fooled both the participants, the team leaders, the grading team, and the author of the problem: we all calculated the mean power on the basis of the absolute angular velocity ω of the satellite. Only during the writing of this final report it was recognized that the relative angular velocity $\omega \pm \Omega$ must be used when calculating the mean power. The natural meaning of 'mean power' of a periodic process is the work done during one period divided by the length of that period. In one period there are the four positions of any single body B, thus the length of the period must be the time of one relative revolution of the satellite (relative with respect to the local vertical direction). Question 2 says ambiguously: 'averaged over one rotation of the satellite', but the only sensible interpretation of this is 'averaged over one rotation with respect to the local vertical'!

5. Usual mistakes in the solutions. In many solutions the decrease of tension in the side position was not recognized at all, it was assumed that the tension in side position is $\omega^2 r m$. (The author of the problem first made this error, too. Only two days before the competition he got this part of the solution right.) If the vector formalism is used, then this decrease appears automatically. It can also be obtained by means of a geometrical diagram where the difference of the 'vertical' directions at P and at B is taken into account.

In a surprising number of solutions the tensions in up and down positions were wrong because of the following mistake: it was assumed that the body B was performing one circular motion with angular velocity ω and radius r and the second circular motion with Ω and $R + r$ (when considering the up position). This results in an excessive tension for the up position. Often there was also another error which caused the tension in the down position to be too small. Such a situation is not consistent, but the competitors did not make a consistency check.

In many solutions it was erroneously assumed that the angular momentum $4m\omega r^2$ of the rotation of the satellite about its centre point P would be conserved. If this were true, then also ω would not be changed by the work done by the machines. The gravitational forces acting on B are not directed towards the centre of the satellite, they are not *central forces* with respect to the centre of the satellite. Thus there is no reason for assuming that the angular momentum or ω would remain constant.

It seems that a few competitors remembered the classical example of conservation of angular momentum: a skater accelerates his/her pirouette by pulling arms close to the body. It was thought that the work done by the machines goes for increasing the angular velocity of the satellite. In small scale, this would seem to be true: pulling one body B closer to P would indeed speed up ω . The effect would not be cumulative, however: later the same B would recede back to the original distance and there would be a slowing down of ω back to the original value. Without the inhomogeneous gravitational field, there would be no cumulative change of ω . Furthermore, the problem was by purpose formulated so that while two bodies get closer to P, another

PROBLEM **1**: A ROTATING SATELLITE.

two recede from P. Thus the moment of inertia of the satellite does not change and there is no fluctuation of the value of ω .

In a few solutions the numerical values for maximum and minimum forces were rounded to two significant figures before calculating the difference. But then the error in the difference of two nearly equal forces may be nearly 100 %!. It is essential to maintain full accuracy in the intermediate results.

6. Experience with the fill-in table The fill-in table was introduced in the hope of achieving the following:

- Eliminating unnecessary explanations from the answers, thus making it possible to grade the answers with a minimum of language translations. It was thought that by asking sufficiently many details one can get a complete picture of whether the competitor does or doesn't understand the situation.
- Making the grading process fast, objective, and straightforward, treating all the participants justly and on equal basis.

These goals were only partly fulfilled:

It was possible to see if a competitor had a good understanding of the situation. Then all or almost all entries of the table were well answered. However, it was somewhat problematic how to deal with partly filled tables. Many answers contained such relations which are trivially true for all circular Kepler orbits. This had not been expected. It was necessary to formulate a policy about how to deal with true answers which did not address the intended matters.

The last question was unfortunately formulated so that it could be understood in two different ways. Also, this question was not supported by other related questions. Thus it was difficult to decide how to grade half-correct answers to the last question. Our experience indicates that a fill-in table may be a good device in making the grading process easier and more objective. However, it requires a good deal of careful planning and also test filling by a number of persons in order to eliminate multiple meanings of the questions.

PROBLEM 2: THE LONGITUDINAL MOTION OF A LINEAR MOLECULE

In this problem you will analyze the longitudinal motion of a linear molecule, i.e., the motion along the molecular axis. The rotational motion and the bending of the molecule are not considered. The molecule is assumed to consist of N atoms of mass m_1, m_2, \dots, m_N , respectively. Each atom is assumed to be connected to its neighbors by a chemical bond. Each bond is approximated by a massless spring which obeys Hooke's law with spring constants k_1, k_2, \dots, k_{N-1} . The molecule is shown in Fig. 1.

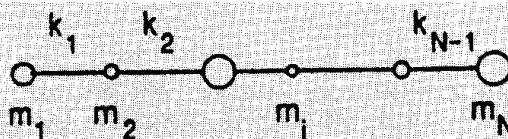

Fig.1. A linear molecule with N atoms.

Use the following facts when solving this problem: The longitudinal vibrational motion of a linear molecule consists of a superposition of separate vibrational motions called normal vibrations, or normal modes. In a normal mode all atoms vibrate in simple harmonic motion with the same frequency and pass through their equilibrium positions simultaneously.

Questions

1) Let x_i be the displacement of atom i from its equilibrium position. Express the force F_i acting on each atom i as a function of the displacements x_1, x_2, \dots, x_N and the spring constants k_1, k_2, \dots, k_{N-1} . What relationship is there among the forces F_1, F_2, \dots, F_N ? Using this relationship, derive a relationship between the displacements x_1, x_2, \dots, x_N and give a physical interpretation of this relationship.

2) Analyze the motion of a diatomic molecule AB (Fig. 2). The value of the spring constant is k . Derive an expression for the forces acting on atoms A and B. Determine the possible types of motion of the molecule. Determine the corresponding vibrational frequencies and interpret the result. In particular, how is it possible for the atoms to vibrate with the same frequency even though their masses are not the same?

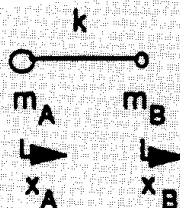

Fig. 2. The diatomic molecule AB

3) Analyze the motion of the triatomic molecule BA_2 (Fig. 3)

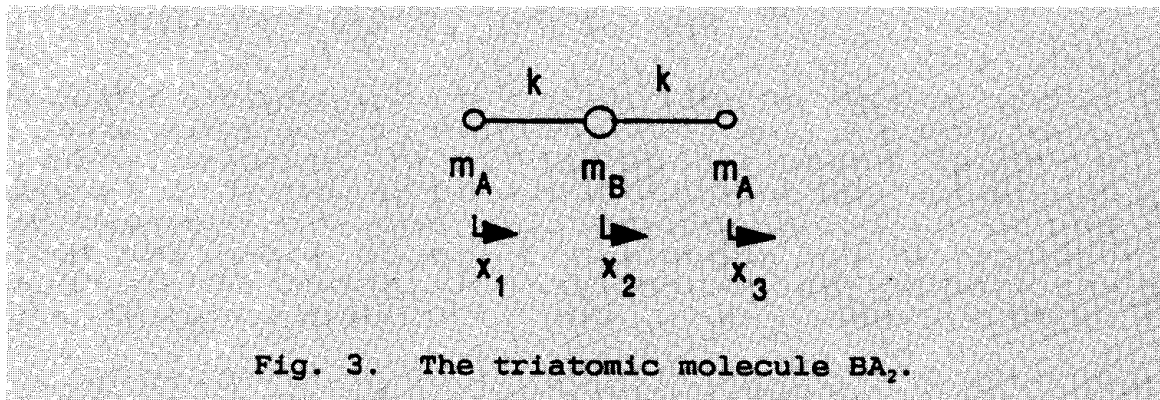

Fig. 3. The triatomic molecule BA_2 .

Express the net force on each atom as a function of its displacement only. Deduce the possible motions of the molecule and the corresponding vibrational frequencies.

4) The frequencies of the two longitudinal modes of vibration of the CO_2 molecule are 3.998×10^{13} Hz and 7.042×10^{13} Hz, respectively. Determine a numerical value for the spring constant of the CO bond.

How well do you think this approximation for the bond structure of the molecule describes the vibrational motion of the real molecule?

The atomic mass of the carbon atom = 12 amu and that of the oxygen atom = 16 amu. The atomic mass unit = 1.660×10^{-27} kg.

SOLUTION : PROBLEM 2

The solution is given as several basically equivalent versions. The problem is formulated in such a way that no knowledge of matrix theory as applied to problems of this kind is assumed. However, as many of the participants produced elegant and balanced solutions using matrix theory, a brief sketch of this kind of solution is also presented below.

1) The force on atom i can be deduced from Fig. 1. below.

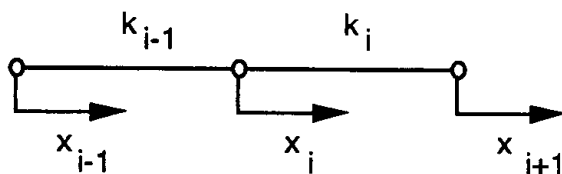

SOLUTION : PROBLEM 2

A positive displacement x_{i-1} of atom $i-1$ causes a shortening of the spring k_{i-1} . That causes a force $k_{i-1}x_{i-1}$ (acting to the right) on atom i . Correspondingly, a displacement x_i of atom i causes a force $-k_{i-1}x_{i-1} - k_i x_i$ acting to the left on atom i . Finally, a displacement x_{i+1} on atom i causes a force $k_{i+1}x_{i+1}$ acting to the right on atom i . The forces on atom i add up to

$$F_i = -k_{i-1}(x_i - x_{i-1}) - k_i(x_i - x_{i+1}) \quad (1)$$

Taking into account that atom 1 has no left neighbor and atom N no right neighbor, the forces can be written

$$\begin{aligned} F_1 &= -k_1(x_1 - x_2) \\ F_2 &= -k_1(x_2 - x_1) - k_2(x_2 - x_3) \\ &\dots \\ F_i &= -k_{i-1}(x_i - x_{i-1}) - k_i(x_i - x_{i+1}) \\ &\dots \\ F_N &= -k_{N-1}(x_N - x_{N-1}) \end{aligned} \quad (2)$$

Adding up the forces gives the total force F acting on the molecule:

$$F = F_1 + F_2 + \dots + F_N = 0 \quad (3)$$

According to Newton's second law, this force equals the mass of the molecule multiplied by the acceleration of its center of mass:

$$F = Ma = 0 \quad (4)$$

Each separate force equals the mass of the corresponding atom multiplied by the acceleration of that atom:

$$F_i = M_i a_i \quad (5)$$

(3) and (5) together give

$$m_1 a_1 + m_2 a_2 + \dots + m_N a_N = 0 \quad (6)$$

Relation (6) gives

$$m_1 v_1 + m_2 v_2 + \dots + m_N v_N = M v_0 = \text{constant} \quad (7)$$

PROBLEM 2: THE LONGITUDINAL MOTION OF A LINEAR MOLECULE

where v_0 denotes the velocity of the center of mass. If the molecule is observed in a coordinate system moving with the center of mass, this velocity equals zero. Thus, we find the following relation between the displacements of the separate atoms:

$$m_1x_1 + m_2x_2 + \dots + m_Nx_N = Mx_0 = \text{constant} \quad (8)$$

This constant can be set equal to zero, meaning that the origin coincides with the center of mass of the molecule and that the motion of the center of mass is not influenced upon by the internal forces of the molecule .

2) The molecule and the pertinent quantities are shown in the figure below:

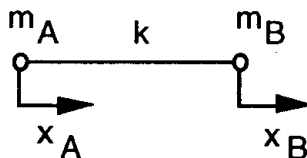

The forces on the atoms can be expressed as

$$\begin{aligned} F_A &= -k(x_A - x_B) = m_A a_A \\ F_B &= -k(x_B - x_A) = m_B a_B \end{aligned} \quad (9)$$

Again,

$$F_A + F_B = m_A + m_B = 0 \quad (10)$$

In the center - of - mass system there correspondingly holds

$$m_A x_A + m_B x_B = 0 \quad (11)$$

and further

$$x_B = -\frac{m_A}{m_B} x_A \quad (12)$$

SOLUTION : PROBLEM 2

Relations (9) can then be written

$$\begin{aligned}
 F_A &= -k\left(x_A + \frac{m_A}{m_B} x_A\right) = -k\left(\frac{m_A + m_B}{m_A}\right)x_A \\
 F_B &= -k\left(x_B + \frac{m_B}{m_A} x_B\right) = -k\left(\frac{m_A + m_B}{m_B}\right)x_B
 \end{aligned}
 \tag{13}$$

According to the formulation of the problem, the force on each atom is proportional to its displacement. This can be expressed as

$$\begin{aligned}
 F_A &= -r_A x_A \\
 F_B &= -r_B x_B
 \end{aligned}
 \tag{14}$$

The proportionality constants r_A and r_B are obtained by comparing (13) and (14):

$$r_A = k\left(\frac{m_A + m_B}{m_B}\right); \quad r_B = k\left(\frac{m_A + m_B}{m_A}\right)
 \tag{15}$$

The crucial point in the solution is now to utilize the fact given in the formulation of the problem that the atoms vibrate with equal frequencies:

$$\omega_A = \sqrt{\frac{r_A}{m_A}} = \sqrt{\frac{m_A + m_B}{m_A m_B}} = \omega_B
 \tag{16}$$

The other solution to be deduced from Eqns. (9) and (11) is the trivial one corresponding to

$$x_A = x_B
 \tag{17}$$

giving $w = 0$, which corresponds to a uniform translation of the molecule without vibrational motion, or in the center-of-mass system, to a molecule at rest.

Another possible solution is obtained by assuming that x_A and x_B are proportional to each other, as can be inferred from the solution to Part 1 of the problem. Thus, we set

$$x_B = c x_A
 \tag{18}$$

Inserting (18) into (13) gives

$$\begin{aligned}
 F_A &= -k(x_A - c x_A) = -k(1 - c_B)x_A = -r_A x_A \\
 F_B &= -k\left(\frac{1}{c} x_B - x_B\right) = -k\left(\frac{1}{c_B} - 1\right)x_B = -r_B x_B
 \end{aligned}
 \tag{19}$$

PROBLEM 2: THE LONGITUDINAL MOTION OF A LINEAR MOLECULE

The vibrational angular frequencies are

$$\omega_A = \sqrt{\frac{r_A}{m_A}} = \sqrt{\frac{k(1-c)}{m_A}} = \omega_B = \sqrt{\frac{r_B}{m_B}} = \sqrt{\frac{k(\frac{1}{c}-1)}{m_B}} \quad (20)$$

Solving the resulting second-degree equation for c gives the earlier derived results

$$c_1 = 1, c_2 = -\frac{m_A}{m_B} \quad (21)$$

The solution $c_1 = 1$ directly gives $F_A = F_B = 0$ without any further conditions on x_A and x_B .

The solution $c_2 = -m_A/m_B$ corresponds to the genuine vibrational motion.

A third way of obtaining the solution is, of course, to use the full equations of motion

$$\begin{aligned} F_A &= m_A \ddot{x}_A = -k(x_A - x_B) \\ F_B &= m_B \ddot{x}_B = -k(x_B - x_A) \end{aligned} \quad (22)$$

and assuming harmonic solutions of the form

$$x_A = x_{A0} e^{i\omega t}; x_B = x_{B0} e^{i\omega t} \quad (23)$$

(23) inserted in (22) leads to the linear system of equations

$$\begin{aligned} (k - m_A \omega^2) x_{A0} - k x_{B0} &= 0 \\ -k x_{A0} + (k - m_B \omega^2) x_{B0} &= 0 \end{aligned} \quad (24)$$

Surprisingly many of the participants obtained the solution in this way, correctly utilizing the fact that the condition for a non-trivial solution is that the determinant of the coefficients of the unknowns equal zero:

$$\begin{vmatrix} k - m_A \omega^2 & -k \\ -k & k - m_B \omega^2 \end{vmatrix} = 0 \quad (25)$$

SOLUTION : PROBLEM 2

The solution to this equation again retrieves the earlier results:

$$\omega_1 = 0; \omega_2 = \sqrt{\frac{k(m_A + m_B)}{m_A m_B}} \quad (26)$$

with the amplitudes x_A and x_B obtained as before.

3) The molecule to be analyzed in the third part of the problem is illustrated in the following figure together with the pertinent quantities defined:

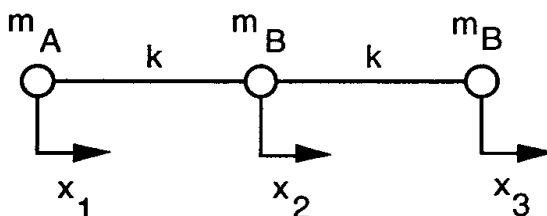

The forces on the atoms are

$$\begin{aligned} F_1 &= -k(x_1 - x_2) \\ F_2 &= -k(x_2 - x_1) - k(x_2 - x_3) = -k(-x_1 + 2x_2 - x_3) \\ F_3 &= -k(x_3 - x_2) \end{aligned} \quad (27)$$

Again we the displacements can be assumed proportional to each other, as the sum of the mass-weighted displacements is a constant:

$$x_2 = c_2 x_1; \quad x_3 = c_3 x_1 \quad (28)$$

where c_2 and c_3 are constants to be determined. According to the formulation of the problem, the participants were supposed to proceed by trying to express the force acting on each atom as a function of the displacement of that particular atom only. Inserting (28) in (27) then gives

$$\begin{aligned} F_1 &= -k(1 - c_2)x_1 = -r_1 x_1 \\ F_2 &= -k\left(-\frac{1}{c_2} + 2 - c_3\right)x_2 = -r_2 x_2 \\ F_3 &= -k\left(1 - \frac{c_2}{c_3}\right)x_3 = -r_3 x_3 \end{aligned} \quad (29)$$

PROBLEM 2: THE LONGITUDINAL MOTION OF A LINEAR MOLECULE

The constants c_2 and c_3 can now be determined from the condition that the atoms vibrate with equal angular frequencies:

$$\omega_1 = \sqrt{\frac{r_1}{m_A}} = \omega_2 = \sqrt{\frac{r_2}{m_B}} = \omega_3 = \sqrt{\frac{r_3}{m_A}} \quad (30)$$

Squaring the roots and using (29) gives the equations

$$\frac{1-c_2}{m_A} = \frac{-\frac{1}{c_2} + 2 - \frac{c_3}{c_2}}{m_B} = \frac{1-c_2}{m_A} = \frac{c_3}{m_A} \quad (31)$$

These equations must hold simultaneously, so that there hold the relations

$$1-c_2 = 1 - \frac{c_2}{c_3} \quad (32)$$

$$\frac{1-c_2}{m_A} = (2 - (1+c_3)\frac{1}{c_2})\frac{1}{m_B} \quad (33)$$

The first of these equations has two different solutions:

- 1) $c_2 = 0$ & $c_3 \neq 0$
 - 2) $c_3 = 1$ & $c_2 \neq 0$
- (34)

The first solution inserted in (33) gives the result

$$\frac{1}{m_A} = (2 - \frac{1+c_3}{c_2})\frac{1}{m_B} \quad (35)$$

If c_2 is directly set = 0 in the right-hand member, the expression diverges. For that not to occur, the expression $1+c_3$ must vanish, implying the result

$$c_3 = -1 \quad (36)$$

Thus, we have

$$x_2 = 0, x_3 = -x_1 \quad (37)$$

SOLUTION : PROBLEM 2

From (29) and (37) we obtain

$$r_1 = k; \omega_1 = \sqrt{\frac{k}{m_A}} \quad (38)$$

The angular frequency ω_3 is equal to ω_1 , because the solution actually was obtained on that condition. An additional complication is that the frequency ω_2 comes out indeterminate, as atom 2 does not move at all in this particular vibrational mode. The participants were not supposed to analyze that fact any further; obtaining the result that the central atom does not move was enough.

The second solution in (34), i.e. $c_3=1$ and $c_2 \neq 0$ gives inserted in (33)

$$\frac{1-c_2}{m_A} = 2\left(1-\frac{1}{c_2}\right)\frac{1}{m_B} \quad (39)$$

This gives a second-degree equation for c_2 :

$$c_2^2 + \left(\frac{2m_A}{m_B} - 1\right)c_2 - \frac{2m_A}{m_B} = 0 \quad (40)$$

The roots of this equation are

$$c_{2,1} = 1; c_{2,2} = -\frac{2m_A}{m_B} \quad (41)$$

The first solution corresponds to equal amplitudes for all atoms, again implying that no bonds are stretched and no vibrational motion occurs. The second root gives

$$F_1 = -k\left(1 + \frac{2m_A}{m_B}\right) = -r_1 x_1 \quad (41)$$

with the corresponding vibrational angular frequency

$$\omega_1 = \sqrt{\frac{r_1}{m_A}} = \sqrt{k\left(\frac{2}{m_B} + \frac{1}{m_A}\right)} \quad (42)$$

PROBLEM 2: THE LONGITUDINAL MOTION OF A LINEAR MOLECULE

As in part 2 of this problem, the solution can also be obtained from the vanishing of the determinant formed from the equations of motion. They are

$$\begin{aligned} F_1 &= m_A \ddot{x}_1 = -k(x_1 - x_2) \\ F_2 &= m_B \ddot{x}_2 = -k(-x_1 + 2x_2 - x_3) \\ F_3 &= m_A \ddot{x}_3 = -k(x_3 - x_2) \end{aligned} \quad (43)$$

Again assuming an complex exponential solution

$$x_i = x_{i0} e^{i\omega t} \quad (44)$$

a linear system of equations is obtained by factoring out the exponential:

$$\begin{aligned} (k - m_A \omega^2)x_{10} - kx_{20} &= 0 \\ -kx_{20} + (2k - m_B \omega^2)x_{20} - kx_{30} &= 0 \\ kx_{20} + (k - m_A \omega^2)x_{30} &= 0 \end{aligned} \quad (45)$$

The condition for the existence of a non-vanishing solution is again

$$\begin{vmatrix} k - m_A \omega^2 & -k & 0 \\ -k & 2k - m_B \omega^2 & -k \\ 0 & -k & k - m_A \omega^2 \end{vmatrix} = 0 \quad (46)$$

The roots for the determinant are obtained as

$$\omega_1 = 0; \quad \omega_2 = \sqrt{\frac{k}{m_A}}; \quad \omega_3 = \sqrt{k\left(\frac{2}{m_B} + \frac{1}{m_A}\right)} \quad (47)$$

thus reproducing the earlier results. The amplitudes are trivially solved by inserting the roots in the equation system one at a time. This method of solution is, of course, much faster than the one suggested in the text, but it was not assumed that the participants would have to master the more advanced techniques. On the other hand, those who did it were rewarded for a correct solution, even though they took a shorter route demanding less physical reasoning than that suggested in the formulation of the problem.

SOLUTION : PROBLEM 2

4) Within the realm of the model adopted, we note that $\omega_3 > \omega_2$, so that the higher vibrational frequency, i.e. $7.042 \cdot 10^{13}$ Hz, should be set to correspond to ω_3 and the lower one, $3.998 \cdot 10^{13}$ Hz, should be set to correspond to ω_2 . First the correspondence between the angular frequency and the frequency is noted:

$$\omega = 2\pi\nu \quad (48)$$

Thus, there holds

$$\omega_2 = 2\pi\nu_2; \omega_3 = 2\pi\nu_3 \quad (49)$$

The estimates for k come out as

$$\begin{aligned} k_2 &\approx m_A \omega_2^2 \approx 1670 \text{ N/m} \\ k_3 &\approx \left(\frac{m_A m_B}{2m_A + m_B} \right) \omega_3^2 \approx 1420 \text{ N/m} \end{aligned} \quad (50)$$

The agreement is reasonable. The participants were not expected to produce any further speculations as to the reasons for the discrepancy. This part of the problem was rather meant as an illustration of the degree of accuracy inherent in a simple model of the kind presented here.

PROBLEM **3** : A SATELLITE IN SUNSHINE

In this problem you will calculate the temperature of a space satellite. The satellite is assumed to be a sphere with a diameter of 1 m. All of the satellite remains at a uniform temperature. All of the spherical surface of the satellite is coated with the same kind of coating. The satellite is located near the earth but is not in the earth's shadow.

The surface temperature of the sun (its blackbody temperature) $T_{\text{sun}} = 6000 \text{ K}$ and its radius is $6.96 \times 10^8 \text{ m}$. The distance between the sun and the earth is $1.5 \times 10^{11} \text{ m}$. The sunlight heats the satellite to a temperature at which the blackbody emission from the satellite equals the power absorbed from the sunlight. The power per unit area emitted by a blackbody is given by Stefan-Boltzmann's law $P = \sigma T^4$ where σ is the universal constant $5.67 \times 10^{-8} \text{ W}\cdot\text{m}^{-2}\text{K}^{-4}$. In the first approximation, you can assume that both the sun and the satellite absorb all electromagnetic radiation incident upon them.

1) Find an expression for the temperature T of the satellite. What is the numerical value of this temperature?

2) The blackbody radiation spectrum $u(T, f)$ of a body at temperature T obeys Planck's radiation law

$$u(T, f) df = \frac{8\pi k^4 T^4}{c^3 h^3} \frac{\eta^3 d\eta}{e^\eta - 1}$$

where $\eta = hf/kT$ and $u(T, f)df$ is the energy density of the electromagnetic radiation in a frequency interval $[f, f + df]$. In the equation $h = 6.6 \times 10^{-34} \text{ J}\cdot\text{s}$ is Planck's constant, $k = 1.4 \times 10^{-23} \text{ J}\cdot\text{K}^{-1}$ is Boltzmann's constant, and $c = 3.0 \times 10^8 \text{ m}\cdot\text{s}^{-1}$ is the speed of light.

The blackbody spectrum, integrated over all frequencies f and directions of emission, gives the total radiated power per unit area $P = \sigma T^4$ as expressed in the Stefan-Boltzmann law given above.

$$\sigma = \frac{2\pi^5 k^4}{15 c^2 h^3}$$

The figure shows the normalized spectrum

$$\frac{c^3 h^3}{8\pi k^4} \frac{u(T, f)}{T^4}$$

as a function of η .

In many applications it is necessary to keep the satellite as cool as possible. To cool the satellite, engineers use a reflective coating that reflects light above a cut-off frequency but does not prevent heat radiation at lower frequency from escaping. Assume that this (sharp) cut-off frequency corresponds to $hf/k = 1200 \text{ K}$.

What is the new equilibrium temperature of the satellite? The exact answer is not needed. Therefore, do not perform any tedious integrations; make approximations where necessary. The integral over the entire range is

$$\int_0^{\infty} \frac{\eta^3 d\eta}{e^{\eta} - 1} = \frac{\pi^4}{15}$$

and the maximum of $\eta^3/(e^{\eta} - 1)$ occurs at $\eta \approx 2.82$. For small η you can expand the exponential function as $e^{\eta} \approx 1 + \eta$.

3) If we now have a real satellite, with extending solar panels that generate electricity, the dissipated heat in the electronics inside the satellite acts as an extra source of heat. Assuming that the power of the internal heat source is 1 kW, what is the equilibrium temperature of the satellite in case 2 above?

4) A manufacturer advertises a special paint in the following way:

"This paint will reflect more than 90% of all incoming radiation (both visible light and infrared) but it will radiate at all frequencies (visible light and infrared) as a black body, thus removing lots of heat from the satellite. Thus the paint will help keep the satellite as cool as possible."

Can such paint exist? Why or why not?

5) What properties should a coating have in order to raise the temperature of a spherical body similar to that of the satellite considered here above the temperature calculated in 1?

$$\frac{c^3 h^3}{8\pi k^4} \frac{u(T, f)}{T^4}$$

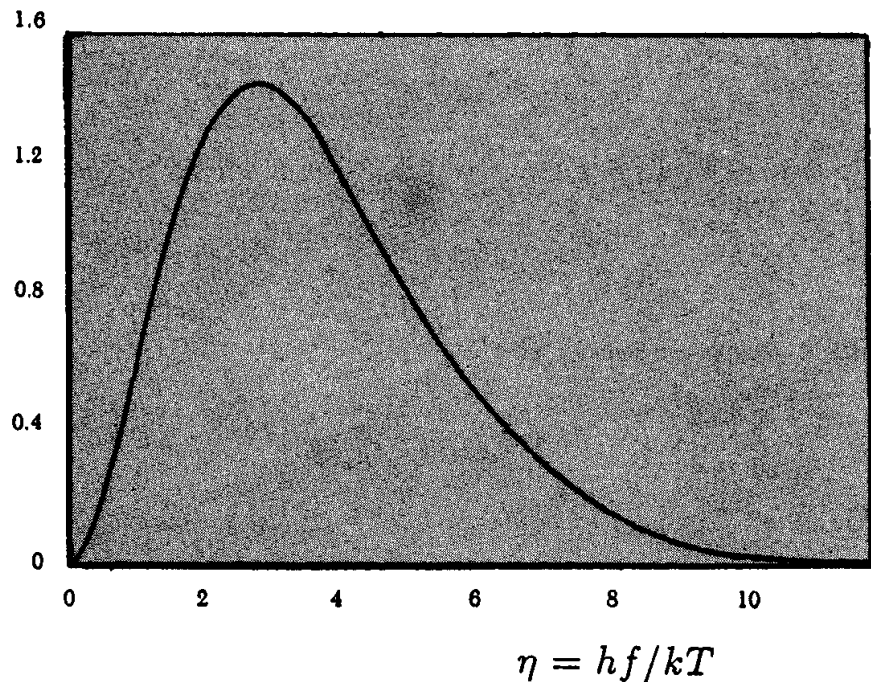

SOLUTION : PROBLEM 3

1. Over the whole surface of the sun, the emitted energy is $4\pi R_{Sun}^2 \cdot \sigma T_{Sun}^4$. All this energy passes through a spherical shell at earth's distance R , where the intensity now is $4\pi R_{Sun}^2 \cdot \sigma T_{Sun}^4 / 4\pi R^2$.

The satellite is a circular object absorbing

$$\pi r_{sat}^2 \cdot \frac{4\pi R_{Sun}^2 \cdot \sigma T_{Sun}^4}{4\pi R^2}$$

but a spherical object emitting $4\pi r_{sat}^2 \cdot \sigma T_{sat}^4$.

Equating this absorption and emission we get $T_{sat} = T_{Sun} \sqrt{\frac{R_{Sun}}{2R}}$ giving $T_{sat} = 289 \text{ K} = 16 \text{ }^\circ\text{C}$.

2. We have to calculate what part of the absorbed power comes from the part of the spectrum below 1200 K.

$$\eta_{cutoff} = \frac{1200 \text{ K}}{6000 \text{ K}} = 0.2 \ll 1$$

This fraction of power is

$$\begin{aligned} \delta &= \int_0^{\eta_{cutoff}} \frac{\eta^3 d\eta}{e^\eta - 1} / \int_0^{\eta_\infty} \frac{\eta^3 d\eta}{e^\eta - 1} \\ &\approx \int_0^{\eta_{cutoff}} \eta^2 d\eta / \frac{\pi^4}{15} = \frac{\eta_{cutoff}^3}{3} / \frac{\pi^4}{15} = 4.1 \cdot 10^{-4} \end{aligned}$$

Now, the satellite is cold with respect to 1200 K so we ignore that a small part of the satellite blackbody emission will be retained. The energy balance is now

$$4\pi r_{sat}^2 \cdot \sigma T_{sat}^4 = \delta \cdot \pi r_{sat}^2 \cdot \frac{4\pi R_{Sun}^2 \cdot \sigma T_{Sun}^4}{4\pi R^2}$$

by which the new satellite temperature is the previous corrected by a factor $\delta^{1/4}$

$$T_{sat} = (4.1 \cdot 10^{-4})^{1/4} \cdot 289 \text{ K} = 41 \text{ K}$$

3. The whole absorbed energy is

$$\delta \cdot \pi r_{sat}^2 \cdot \frac{4\pi R_{Sun}^2 \cdot \sigma T_{Sun}^4}{4\pi R^2} = 0.5 \text{ W}$$

which is small (ignorable) compared to $P_{internal} = 1 \text{ kW}$. Thus the energy balance becomes

$$P_{internal} = 4\pi r_{sat}^2 \cdot \sigma T_{sat}^4$$

PROBLEM **3** : A SATELLITE IN SUNSHINE

giving $T_{sat} = 274$ K ($\eta = 4.38$). Note: strictly speaking, this is not accurate, because for a blackbody radiation of 274 K, some 33 % of the emitted power lies above the 1200 K cutoff ! This means that the satellite has to be hotter, to emit all of the 1 kW in frequencies below the cutoff. The resulting integral equation is

$$\left(\frac{\eta}{4.38}\right)^4 = \int_0^{\eta} \frac{\eta^3 d\eta}{e^{\eta} - 1} / \frac{\pi^4}{15}$$

which can be solved numerically by iteration. The true solution is $\eta = 3.80$ corresponding to a temperature of 316 K.

4. The paint cannot exist, because it would violate the second law of thermodynamics. The physics textbook explanation is the principle of detailed balance, which means that for equilibrium to exist, the emission and absorption in a given frequency interval must match exactly. This should not be confused with the fact that reflection and absorption can be quite different. If the manufacturer's paint existed, one could create a temperature difference between two bodies in a closed system, and hence a perpetum mobile.
5. The coating should be transparent for high frequencies (in the range of the peak or tail of the sun's radiation), but reflective and hence insulating at low frequencies (the satellite temperature).

XXIII INTERNATIONAL PHYSICS OLYMPIAD

HELSINKI, ESPOO

EXPERIMENTAL COMPETITION

July 9th 1992

available time: 2 x 2 1/2 hours

READ THIS FIRST

After two and half hours you must stop carrying out your first experiment and go to another room for the second experiment.

Instructions:

1. Use no other pen than the one allotted by the organizers
2. Do not use the same paper for different problems.
3. Use only the marked side of the paper
4. Write at the top of each and every page:
 - the number of the problem
 - the number of the page per problem, starting by number 1
 - the total number of pages per problem

Example: 1 1/4; 1 2/4; 1 3/4; 1 4/4

5. Mark the graph papers with your identification.

EXPERIMENTAL PROBLEM 1

Investigation of the Electric Breakdown of Air

In this experimental problem the electric breakdown of air is to be studied by means of high voltages generated by piezoelectric material.

The experimental apparatus consists of an inclined slide (see figure) on which a hammer of mass m can slide down a guide rail. The sliding hammer then hits an assembly of two cylinders of piezoelectric material and compresses them. Compression of the piezoelectric material causes electric charging of the ends of the cylinders. The generated voltage is conducted to an adjustable spark gap. If the gap is small enough there will be a spark across the gap which can be seen by the naked eye. However, if the voltage is too small, there will be no spark. The smallest voltage that produces a spark over a given gap is called the breakdown voltage of the gap.

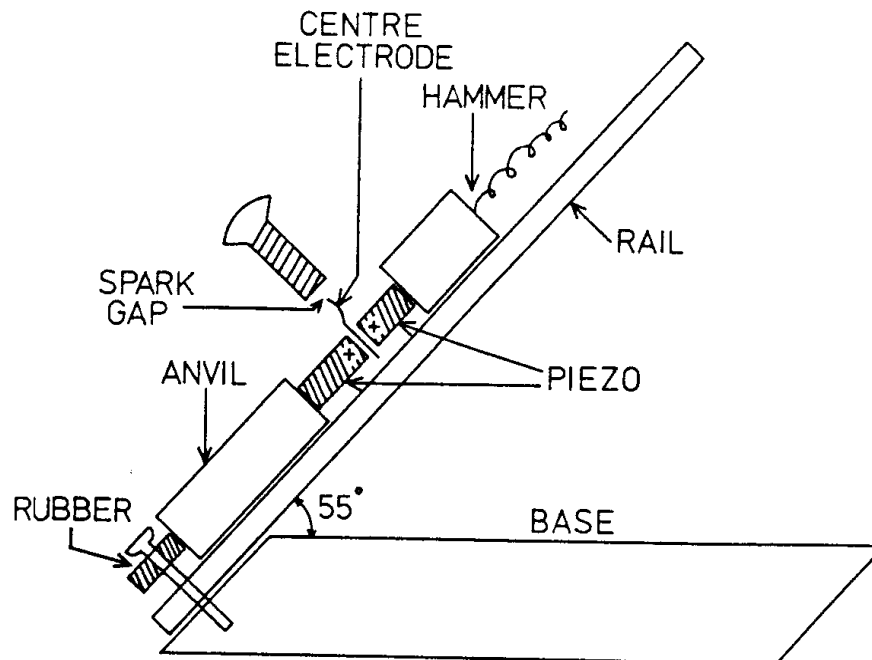

Instructions

- o determine the breakdown voltage as a function of the gap width;
- o estimate the errors in the results, and discuss the nature of the various errors.

In your report,

- o explain your experimental procedure;
- o explain how you have overcome the experimental difficulties in performing the measurements;
- o discuss the general validity of this result in other situations in which electrical breakdown of air occurs;
- o write down the serial number on your piezoelectric assembly so that your results can be checked.

Discussion of the theory for a piezoelectric cylinder

The full theory of a piezoelectric is not required in this experiment. The following approximate analysis is sufficient.

The piezoelectric cylinder can be modelled as a combination of a mechanical spring and an electric capacitor. The two ends of the cylinder act as the plates of the capacitor. When the spring is compressed, the compressing movement causes electric charge to move from one plate of the capacitor to the other plate, causing a voltage to appear across the capacitor. The quantity of charge moved is proportional to the amount of compression. The process is reversible: when the compressing force is released and the material resumes its original shape, an opposite movement of charge takes place. Consider the following sequence of events with a piezoelectric cylinder of capacitance C : 1) a force is applied on the cylinder; 2) the two ends of the cylinder are momentarily short circuited; and 3) the force is removed. In (1), a charge Q is transferred and the voltage $U = Q/C$ appears across the cylinder. In (2), the voltage drops to zero, $U = 0$. In (3), a smaller voltage is generated of opposite sign to the original voltage.

The capacitance of the piezoelectric cylinder is denoted by C_p . When an initially uncharged and unstressed piezoelectric cylinder is compressed so that mechanical work E is done by the compressing force, then energy $K \times E$ is transformed into electrical energy and stored in the capacitor (capacitance C_p). The value of the constant K depends on the piezoelectric material. The manufacturer of the piezoelectric cylinders used in this experiment reports that

$$K = 0.5.$$

Performing the experiment

The piezoelectric assembly supplied has been made so that compression causes a positive charge to appear in the ends of the piezoelectric cylinders which are marked + in the figure. The + ends are connected to each other and to an electrode in the centre of the assembly which acts as one terminal of the spark gap.

The apparatus is arranged so that the hammer makes electrical contact with the upper end of the top piezoelectric cylinder, thus connecting the piezoelectric material with the metal rail.

There is a larger mass which acts as an anvil below the piezoelectric assembly. The compressing force is generated by the combined action of the hammer and the anvil. The anvil is supported on a cushion of foam rubber so that no sudden impact force is transmitted from the anvil to the base of the equipment. The anvil provides an electrical connection between the lower end of the bottom piezoelectric cylinder and the rail. There is a copper wire connected from the rail to an adjusting screw which serves as the other terminal of the spark gap.

There is a limiter on the rail which prevents the hammer from exceeding a height of approximately 10 cm. Do not attempt to bypass this limiter. Contact the invigilator if you are unable to observe any sparks at all.

There are two methods for observing the sparks:

1. Visual observation of the spark. If this method is used, then it is necessary to make the electrical connection between the adjusting screw and the sliding rail.
2. Feeling the spark with your finger. If this method is used, disconnect the grounding wire and instead, touch one finger to the screw and another finger to the metal rail. The spark current will go through your hand and you will be able to feel whether there is a spark or not.

You can use whichever method you prefer, or both methods if you wish.

In addition to the apparatus discussed above, a triangular ruler/protractor, a small screw driver, and some sheets of graph paper are provided.

Data for the experimental apparatus

Acceleration due to gravity	$g = 9.82 \text{ m/s}^2$
Capacitance of one piezoelectric cylinder	$C_p = 20 \text{ pF} \pm 2 \text{ pF}$
Mass of the hammer	$m = 34.6 \text{ g}$
Combined mass of the piezoelectric assembly and anvil	$M = 87.5 \text{ g} \pm 0.5 \text{ g}$
Angle of the slide rail with respect to the horizontal direction	$= 55^\circ \pm 1^\circ$
Pitch of the thread on the screw used for adjusting the spark gap	$= 0.80 \text{ mm/turn}$

Notes

1. The capacitor equivalent of the piezoelectric cylinder, C_p , has a very low leakage current, thus it can keep a charge for a long time. Bear this fact in mind when planning your experimental procedures.
2. The electrical charge generated by the piezoelectric material is so small that it is not dangerous. The spark does not hurt but you can feel it!
3. There is a small risk that the piezoelectric cylinders could shatter into pieces because of the repeated impacts. If this should happen, contact the organizers: there are spare cylinders available. In order to avoid breakages, make sure that the piezoelectric assembly rests properly on the rail and is pressed securely against the anvil before each impact. Suspend the hammer by the thread supplied before letting it slide, so that it will slide smoothly without jumping.
4. The capacitance of the spark gap is so small that it need not be taken into account.
5. The hammer and anvil are considered to be absolutely rigid bodies, so they are not compressed by the impact.

SOLUTION : EXPERIMENTAL PROBLEM 1

Modelling the physical reality

In many exercises and competition problems the participants are told exactly what to do: to neglect or not to neglect air resistance, friction, flexibility, or other such

SOLUTION : EXPERIMENTAL PROBLEM 1

details. In contrast, this experimental problem is presented in an open form: the goal of the experiment is stated (=determination of the breakdown strength of room air) but the means for achieving this goal are left to the participants. This resembles the situation in real physical research work: something should be measured but there are no set rules about how to proceed with the measurements. If the researcher ignores essential interactions then his/her results are simply wrong and there is no such excuse as 'but I decided to ignore air resistance'. An essential part of the present problem consists of the modelling of the experimental situation and in deciding what interactions to ignore and what to take into account. The simple and natural rule is: take into account all those interactions whose effects exceed or are comparable to the general level of errors in the measurements (provided that these interactions can be modelled). On the other hand, it is not necessary to evaluate such quantities which don't affect the results: the true coefficient of friction is not needed, one can use the apparent coefficient and save some error-prone trigonometric calculations (see below).

The following potentially harmful interactions may be identified:

1. Air resistance. The hammer moves through an air column of length less than 13 cm. The mass of this air column is less than one thousandth of the mass of the hammer. Thus also the energy deposited by the hammer to the turbulent movement of the displaced air is less than one thousandth of the energy of the hammer. This order-of-magnitude estimation indicates that the turbulent drag can be neglected. Also, the general physical experience should indicate that for this kind of motion the viscous drag is smaller than the turbulent drag (=the Reynolds number is greater than unity). Thus also the viscous drag can be neglected. Because the influence of air resistance is so small, we don't expect that air resistance is discussed by the participants.

2. Friction. Some participants felt that because the coefficient of friction was not given it was correct to ignore the friction. A great majority understood the problem in the same spirit as it was given: the friction is essential and the coefficient of friction can be estimated by tilting the device and by observing the motion of the hammer on the tilted rail.

The ideal solution would be as follows: tilt the rail to a selected angle and keep it fixed. Put the hammer on the rail and push it slightly so that it starts to move. If the hammer continues to slide with approximately constant velocity, then the tilting angle is correct for computing the apparent coefficient of dynamic friction (see later). If the hammer stops, then the slope is too small. And if the hammer accelerates down the slope, then the slope is too steep.

Such solutions were also accepted where the coefficient of static friction was determined and used instead of the dynamic friction. It can be estimated simply by tilting the rail until the hammer starts to move. In the present case, the difference between static and dynamic friction is relatively small.

EXPERIMENTAL PROBLEM 1

Investigation of the Electric Breakdown of Air

3. The finite mass of the anvil. In the problem definition it was stressed that no sudden forces are transmitted from the anvil to the main body of the equipment. Thus the anvil, piezo, and hammer must be considered 'free-flying' during the impact and the total impulse of these three bodies is conserved throughout the impact. One part of the kinetic energy of the hammer goes for the compression of the piezo but another part remains as the kinetic energy of these three bodies which are moving together as one piece during the time of strongest compression.

4. Deformations of the hammer and the anvil. Although the anvil is of steel it is somewhat deformable: the impact sends a compression wave travelling down the anvil, and there is some energy in this wave. On one hand, this amount of energy is quite small. On the other hand, it would be practically impossible to estimate this energy during the competition. Thus we included the instruction that the anvil should be considered absolutely rigid. The same applies even more to the hammer which is shorter and thus less resilient.

5. Residual voltage of the piezo condenser. After one impact has been made, the charging status of the piezo condenser is unknown. There may be negative charge which has been formed in the piezo during the decrease of compression after the spark has short-circuited the capacitor. Such a charge would reduce the largest positive charge generated by the next impact and would thus tend to prevent another spark from appearing. Thus it is essential that the piezo is discharged by short-circuiting between the impacts. This is most easily done by short-circuiting the spark gap with the provided screw-driver.

It is important to understand that the piezo may acquire a charge even if no spark is observed. This is due to weak corona discharges which are diffuse and not visible in daylight.

Calculations

We denote by x the length of the sliding path of the hammer and by α the angle between the sliding path and the horizontal direction. When the hammer travels the length x , it descends by the amount $x \sin \alpha$ in the gravitational field of earth. So it converts the gravitational energy

$$E_g = m g x \sin \alpha$$

into mechanical energy.

The gravitational force is represented as the sum of two perpendicular forces:

$$\vec{F}_g = \vec{F}_x + \vec{F}_n$$

where \vec{F}_x is parallel to the sliding path and \vec{F}_n is normal to it:

$$\vec{F}_n = \cos \alpha \vec{F}_g \quad (1)$$

$$\vec{F}_x = \sin \alpha \vec{F}_g \quad (2)$$

SOLUTION : EXPERIMENTAL PROBLEM 1

The frictional force \vec{F}_μ is parallel to \vec{F}_x and

$$F_\mu = \mu F_n$$

where μ is the apparent coefficient of dynamic friction. Energy loss by friction is

$$E_\mu = x \mu F_n = \mu m g x \cos \alpha .$$

For determining the apparent coefficient of friction one has to determine an angle β so that when the sliding path has the sloping angle β , the hammer slides without losing or gaining energy. Then frictional energy loss equals gravitational energy gain:

$$E_\mu = x \mu F_n = \mu m g x \cos \beta = E_g = m g x \sin \beta .$$

This gives $\mu = \tan \beta$.

Energy of hammer before impact is thus

$$E_H = E_g - E_\mu = \frac{1}{2} m v_1^2$$

where v_1 is the velocity of the hammer when the impact is about to start. Conservation of impulse gives the velocity v_2 of the combination hammer + piezo + anvil when there is maximum compression, i.e. when all three move as one piece:

$$m v_1 = (m + M) v_2 \quad (3)$$

$$v_2 = \frac{m v_1}{m + M} \quad (4)$$

At maximum compression there is no relative movement of the three bodies with respect to each other. Thus the kinetic energy of the three bodies is obtained from the common movement:

$$E_2 = \frac{1}{2} v_2^2 (M + m) \quad (5)$$

$$= \frac{1}{2} v_1^2 \frac{m^2}{M + m} = \frac{m}{M + m} E_H . \quad (6)$$

Kinetic energy used for compressing the piezo is the difference of the kinetic energies before impact and at maximum compression:

$$E_p = E_H - E_2 \quad (7)$$

$$= \frac{M}{M + m} E_H \quad (8)$$

$$= \frac{M}{M + m} (E_g - E_\mu) \quad (9)$$

The fraction K of this energy is used for generating the electrical energy:

$$E_E = \frac{1}{2} C U^2 \quad (10)$$

$$= K \frac{M}{M + m} m g x (\sin \alpha - \mu \cos \alpha) . \quad (11)$$

EXPERIMENTAL PROBLEM 1

Investigation of the Electric Breakdown of Air

The voltage U is solved from the preceding equation:

$$U = \sqrt{\frac{2KMmg(\sin \alpha - \mu \cos \alpha)}{(M+m)C}} \sqrt{x}. \quad (12)$$

Here C is the combined capacitance of the two piezo capacitors in parallel: $C = 40 \pm 4$ pF.

In the problem, the coefficient K is reported without an error estimate (again, typical for a real experimental situation). It is an empirical quantity. It would be incorrect to assume that it is an exact value. One could assume that $K = 0.5 \pm 0.05$ or $K = 0.5 \pm 0.1$.

Measurements and presentation of results

The gap width d should be determined by using the electrode screw as a micrometer. It is natural to do the measurements with one turn intervals.

The object of this work is to investigate electrical breakdown. As the measurements will show, there is considerable scatter or randomness in the phenomenon. If only some 'best' or mean values are reported, then an important part of information is left out. One should report the original data in a suitable format, either as a table or as a diagram.

The measurements are best organized so that one gap setting at a time is investigated. One should try several falling heights, so that for the lowest heights, no sparks are seen, and for the highest, all trials produce a spark. For each height, several trials should be made.

It might be good to record all results immediately in graphical form in a diagram where abscissa axis shows the gap width d and the ordinate axis shows x , the sliding length of the hammer. The result of each trial should be recorded in this diagram as a mark, e.g. so that a mark '+' is drawn if there is a spark, and a mark '0' is drawn if there is no spark. The set of marks corresponding to same values d and x should be drawn as a cluster of marks near each other. This diagram would show the randomness of the phenomenon. Then one should find the representative values of (x, d) for breakdown from this diagram (see next paragraph). It would be enough to do the conversion to voltage only for these representative values, not for all observations.

There is also the question of what is meant with the concept 'breakdown voltage'. The wording of the problem defines it as 'the smallest voltage that produces a spark over a given gap'. It would be better to interpret this so that breakdown voltage is 'the smallest voltage where the majority of experiments produce a spark'. Such voltage values can be visually determined from the figure.

Another diagram should be drawn, showing how the voltage values depend on the gap length. When the task is to investigate *the voltage* it is not enough to show a diagram of falling heights.

SOLUTION : EXPERIMENTAL PROBLEM 1

Some participants understood the problem so that a coefficient would be needed which would give the ratio of breakdown voltage and gap length, i.e. express the breakdown voltage in 'Volts/millimeters'. Because spark formation is quite nonlinear such a coefficient is not very meaningful and we ignored that part of computed results. However, some competitors also fitted a straight line or a curve to their results so that this line or curve went through the origin. Offering such a diagram as part of the results was considered an outright error because it would communicate to the reader of a research report an interpretation of the data which is unfounded by the observations and contradicts known theory.

Analysis of errors

There was the question about general validity of results. One should mention that spark formation depends strongly on humidity and on electrode shape, and also on the duration of the high tension pulse and on air pressure. Thus the results are without any general validity whatsoever. This should be mentioned in the report.

A complete analysis of errors should consider systematic and random errors separately. The errors in C , α , g , m , and M are systematic, they are same for all individual measurements made with one equipment. Thus the random errors are small (due to x and d and variation of μ), and the relative accuracy of the readings is rather high, certainly better than 10 %. On the other hand, considerable scatter is seen in the results. Thus one might conclude that most part of the scatter of results must be due to the random nature of the fast spark process itself (possibly due to the presence or non-presence of suitable free ions or aerosol particles for initiating the discharge).

Grading

Experimental results might be graded by the quality of the obtained results. In this case it was not possible because of the following reasons:

1. The conditions in the room could not be fully controlled. Both humidity and illumination levels varied throughout the day, causing correct results to change and making the observation of sparks more difficult in the brighter light of noon time.
2. There were probably some individual differences between the different piezo devices. Also, it was possible that an invisible crack was formed in the piezo during one experimental session so that it influenced the next competitor without his/her own fault. Thus all results of different numerical values were accepted if their order of magnitude was reasonable.

The schedule for grading the experimental problems was extremely tight. Thus it was decided to use a fixed grading table. The entries and their values were as follows:

EXPERIMENTAL PROBLEM 1

Investigation of the Electric Breakdown of Air

Acceptable results (3 points -1 -1/2)

This required that there are in table form or graph form the results (voltage vs. gap) and that these results are reasonable: we required that the correct equation for energy of a capacitor had been used etc. Also it was required that the values are not meaningless. We did not consider acceptable such results which were smaller than a few hundreds of volts or more than 1 MV!

From these 3 points we subtracted one point if a line or curve had been fitted to the points so that this curve was forced to run straight to origin, implying that voltage is inherently proportional to gap length. We regarded this as a non-physical assumption which is seriously distorting the results.

If the competitor did not know the unit pF we deducted half a point from those 3 points. Even if this unit is not normally used in schools in some countries, we regard it as common physical knowledge which should be mastered. And assuming that nano is known, pico cannot mean the same. Thus one can logically conclude that 10^{-12} is the only probable choice because 10^{-15} would lead to suspiciously high voltages, to hundreds of kilovolts.

Friction correction (1 point)

This credit was given if the (apparent) friction coefficient was estimated empirically by tilting the device. We didn't require the use of the sliding method for determining dynamic friction, as described earlier in this report. This credit was not given if the friction coefficient was guessed or specifically ignored.

Center-of-mass energy (2 points)

If the factor $M/(m + M)$ was present, two points were given.

Error estimate of K (1/2 point)

In reality the value given for K is probably the largest single cause for error of the results. In good real work it would be necessary to calibrate the equipment when the error of K is not given. Now it was not possible to calibrate. Thus the error of K could not be properly estimated. However, we required that K is recognized as a source of error and that the uncertainty of K is assumed to be at least 0.05 units. Fulfilling this requirement earned half a point of credit.

A similar situation is often encountered in real life: one must use a value but there is no easy method of getting a reliable error estimate for it.

Randomness indicated (1/2 point)

The sparking itself is a random process, and the results should indicate some randomness. If all this randomness had been removed in the preliminary treatment of data or if only one set of experiments was made, and randomness was not explained in the report, then we considered that one important result was missing. If randomness was somehow indicated in the results, half a point was given.

SOLUTION : EXPERIMENTAL PROBLEM **1**

General validity (1/2 + 1/2 points)

There is the question about the general validity of the results. The two most important conditions which cause that the results have no general validity are the shape of electrodes and the environmental variables (humidity, air pressure, temperature etc.). It was required that both were mentioned. However, it was considered sufficient if air pressure was mentioned in stead of humidity.

Short circuiting (1 point)

One point was given if it was mentioned in the report that the piezo capacitor was short-circuited between individual trials. A few reports revealed that this was not fully understood: either the short circuiting was only done after a spark, or only after no spark, or it was attempted after the hammer had been raised. However, the full point was given to all who mentioned this detail even if there was some misunderstanding.

Micrometric use of the screw (1 point)

In order to get good results, it is essential to measure the gap by using the screw as a micrometer. If such a technique was mentioned in the report or if it was evident (=if the distance values were multiples of 0.8 mm) then one point was given for this experimental skill. Most competitors received this credit.

Special credits (1/2 + 1/2 points)

A few competitors remarked that there is a depression in the tip of the screw which makes the distance readings inaccurate or biased. Such a remark was awarded an extra half point. The full score of 10 points could be obtained without this half-point. In some cases the rigid scheme does not do full justice. E.g., if there is a good table of dropping distance vs. gap, this does not merit our 'Acceptable results' (3) points. Also, sometimes there is a feel of quality in the work which can't be included in any fixed grading scheme. In such cases an extra bonus of 1/2 points was given. The full score of 10 points is possible without this half- point.

Remarks

Our preliminary experiments clearly indicated that dirt affects the apparent coefficient of friction. Handling the hammer by hands leaves some grease on the cylindrical sliding surface, this grease accumulates dust, and the apparent coefficient of friction is increased. In order to obtain stable results one should clean the hammer and the sliding rail every now and then. For this purpose, a paper towel was included in the equipment which was made available for this problem. But hardly any competitor used the towel! This aspect was ignored in the grading.

EXPERIMENTAL PROBLEM 1

Investigation of the Electric Breakdown of Air

The rail was made of anodized aluminium because it gave a more repeatable friction than uncoated aluminium. The anodized coating is, however, isolating. Thus we had to make a few scratches in the coating below the anvil and the hammer so that the electric current could penetrate the coating without a large voltage drop.

It is quite tiresome to drop the hammer many times from a precisely determined falling height if one has to read the height each time on the provided scale. For this reason, a clothes-peg was supplied as part of the equipment. It was intended to be used as an adjustable stopper so that one lifts the hammer up against the stopper and lets it fall from this position. This procedure would make the repetition of measurements quick and easy. However, only a few of the participants used the clothes-peg in this way. Many of them used the clothes-peg as a pincer for gripping the tail of the hammer although it seemed to make the work harder than without.

The most important concern in constructing, operating and maintaining the piezo impact device is: how to make sure that the impact on the piezo happens uniformly so that the hammer touches all of the surface of the piezo end. This requirement is very strict, the maximum allowable skewness is at most a few μm . The requirement was probably not met by some of the units used in the competition. This can be suspected because ten piezo devices were broken during the competition. — Another reason for breaking can be that the hammer was dropped carelessly, so that it bounced on the rails and hit the piezo in a skewed position. When observing the competitors during the competition one could see that quite a number of them simply did not follow the advice of letting the hammer fall smoothly so that it does not bounce.

EXPERIMENTAL PROBLEM **2**

A Grating and Optical Filters

The following equipment is at your disposal:

- a small torch
- a non-standard reflection diffraction grating, fixed to a plastic block.
The lines on this grating are in the form of circular arcs. Thus the behaviour of the grating is somewhat different from that of an ordinary diffraction grating.
- a few plastic toy blocks, to be used as supports
- several optical 'slides':
 - 1 (red);
 - 2 (red);
 - 3 (blue);
 - 4 (pink);
 - 5 (purple);
 - 6 (grey);
 - 7 (white)
- three sheets of graph paper
- a cardboard box that may be used for supporting the apparatus

- 1) Determine the line separation of the reflection diffraction grating, as accurately as possible. Estimate the error in your result. Explain the theory and describe the experimental method used; draw diagrams where needed. Tabulate your raw experimental data, give your final numerical results complete with errors and an explanation of how you obtained them.
- 2) Slides 1–5 are coloured filters. Find which wavelengths are transmitted or absorbed by them. Report numerical values and error estimates where possible, or otherwise report your results graphically. Identify the optical item in slide 6.
- 3) Slide 7 consists of a wire mesh. Determine the distance between the wires in this mesh for both perpendicular directions. Fully describe your method in the form of a diagram.

Visible light has wavelength between 0.4 and 0.7×10^{-6} m.

Warning

The torch batteries will not last forever. Switch the torch off when you are not using it as otherwise, after 40 minutes, the light will become noticeably dimmer and redder in colour.

SOLUTION : EXPERIMENTAL PROBLEM 2

Place the grating and lamp on a sheet of graph paper possibly by using suitable supporting blocks. Make a mark in the middle of the grating. By looking over the lamp find the mirror reflection (0th order spectrum) in the grating. Align the setup in such a way that a line from the lamp to the mark on the grating is parallel to the lines in the graph paper and then adjust the grating so that the mirror image of the lamp is seen exactly on the mark. For measurement purposes we define an x-axis which is perpendicular to the line from the lamp to the grating and whose origin is located at the intersection of this x-axis and the sighting line (from lamp to mark on the grating). This setup can be called a spectroscope, which is now aligned.

By looking from both sides one can now see a spectrum, actually two on both sides. Because the grid lines on our grating are circular the surface acts as a Fresnel lens that tends to magnify or demagnify the spectrum, but this phenomenon does not affect the angles that need to be measured. Find the side where it is easier to observe the first order spectrum. Find those directions where each colour is seen OVER THE MARK in the grating. Especially identify the directions where the extreme ends of the spectrum, i.e. deep red and violet blue are seen. These directions should correspond to wave lengths 0.7 and 0.4 μm .

Alternately one could perform a symmetric measurement by measuring the ends of the spectra on both sides. But due to the Fresnel lens effect this may be more difficult.

Denote the distance from the grating to the x-axis by L. Denote the measurement from the origin of the x-axis to the point where any of the sighting lines intersect the x-axis by x. Find $\sin(\alpha) = x / \sqrt{x^2 + L^2}$ for each end of the spectrum by using quantities L and x read off the graph paper. Then compute the grid constant from each value as $d = \lambda / \sin(\alpha)$, where λ is 0.4 or 0.7 μm .

Typical values might be as follows:

$$\begin{array}{llll} L = 300 \text{ mm} & x = 139 \text{ mm} & \text{red, } 0.7 \mu\text{m} & d = 1.67 \mu\text{m} \\ & x = 86 \text{ mm} & \text{blue, } 0.4 \mu\text{m} & d = 1.45 \mu\text{m} \end{array}$$

An uncertainty of 2 mm in x will affect d by 0.02 μm in the red end and by 0.03 μm in the blue end. This can be found out by using a calculator. The quantity L can easily be measured more accurately, 1 mm uncertainty will change "red" d by 0.005 μm .

What would be a proper result for the grid constant d? If we assume that the given values for the red and blue ends of the visible spectrum have an uncertainty of 0.05 μm the red end is more reliable. Moreover it is quite possible that an incandescent light bulb radiates weakly in the blue region. Thus one should probably give more weight to the measurement carried out

EXPERIMENTAL PROBLEM 2

A Grating and Optical Filters

with red light. A reasonable result from the values above would be $1.6 \mu\text{m}$ with an uncertainty of $0.15 \mu\text{m}$.

A quick measurement with a red HeNe laser at 633 nm gave a result $d = 1.67 \mu\text{m}$. Actually not all gratings are equal. The nominal value given in technical literature is $1.6 \mu\text{m}$.

After one has determined the grid constant our spectroscope is also calibrated. We do not need really an accurate value of the quantity d if we use the given end points 0.4 and $0.7 \mu\text{m}$ as fixed calibration points. By looking at the spectrum through each of the filters one soon gets an idea about their characteristics that is which colours are transmitted and which are absorbed. Since a human eye is not very suited to absolute intensity measurements the results can be presented as follows:

The following results are from measurements carried out independently before the results from the IPhO students arrived:

The filters (values may not vary very much)

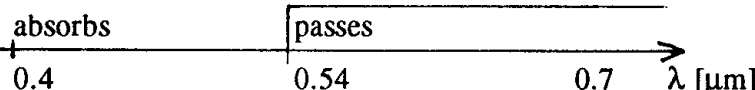
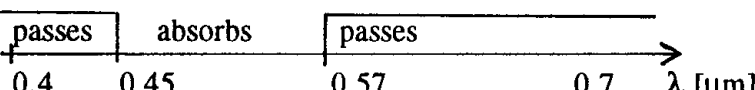
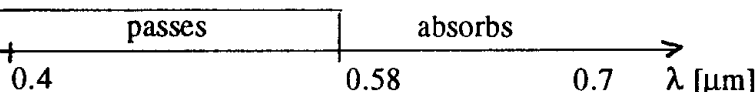
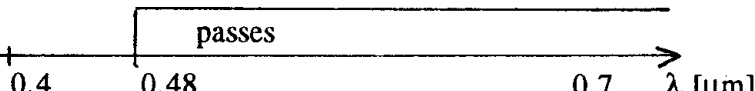
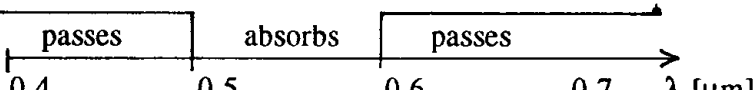
1. 
absorbs violet and blue
2. 
absorbs part of the violet and blue light
3. 
absorbs orange and red light
4. 
absorbs blue light
5. 
absorbs yellow light

SOLUTION : EXPERIMENTAL PROBLEM 2

A few comments can be made about the filters. Numbers 1 and 2 were made of red material used in front of floodlights used for stage lighting. They both transmit red light very well, but there is a small difference in cutoff wave length and moreover number 2 also transmits some blue light, it is almost pink.

Filters 3 .. 5 were made by photographing a VGA colour screen on slide film. They do not have pure colours and they have different characteristics. Number 3 is a high pass, number 4 is a low pass filter, together they make up an almost neutral grey filter. Number 5 is a band reject filter, it does not transmit yellow light.

After the contest these filters were measured by using a spectrophotometer. The results are shown in figures 1 and 2. The cutoff wave lengths in the sketches shown above correspond very well to the measured curves. The eye does not measure intensities reliably as was stated above.

Item number 6 is a polarizer. It can be identified by looking at reflected light from any insulating surface, tabletop, ruler etc. Any LCD display in a watch or calculator will also identify it without difficulty.

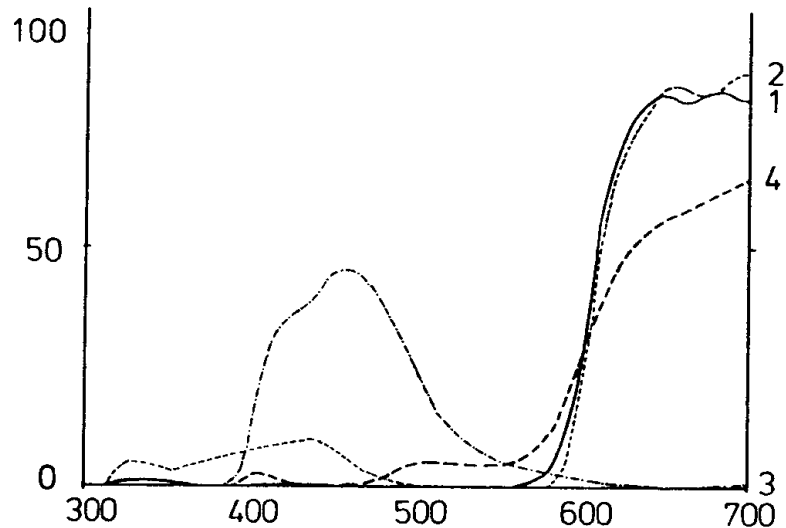

Figure 1

EXPERIMENTAL PROBLEM 2

A Grating and Optical Filters

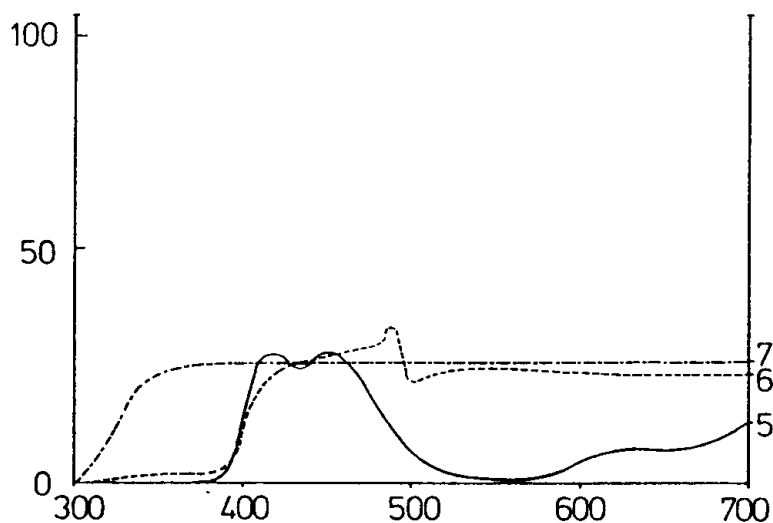
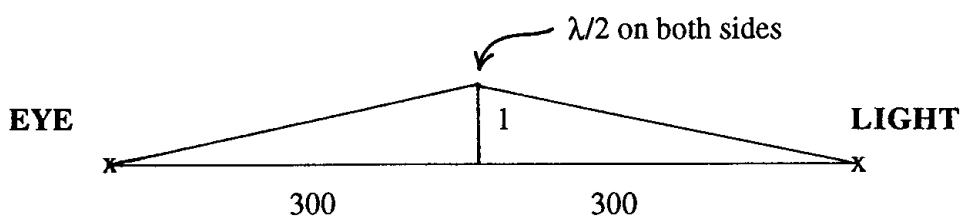

Figure 2

The last item number 7 is a fine mesh as was indicated in the text. By looking at a point light source (which is found if one looks into the penlight bulb from side) through the mesh a two dimensional diffraction pattern can be seen. The grid constant can be determined as follows: Take the mesh and a ruler in your hand so that the ruler is in front of the mesh. Then look through the mesh at the light and keep it half way between your eye and the light. Adjust the distance so that the diffraction pattern matches the millimeter scale on the ruler. Then note the distance between the eye and the light. It is approximately 60 cm. Then the grid constant can be computed from the geometry:



$$0.5 \lambda : d = 1 \text{ mm} : 300 \text{ mm}$$

The middle wave length of visible light is $0.55 \mu\text{m}$ which gives $80 \mu\text{m}$ for the grid constant.

An investigation with a microscope shows that the wires and holes in the mesh are roughly equal in width and that the holes are approximately $50 \cdot 50 \mu\text{m}^2$.

Distribution of the results of the XXIII IPhO

Theoretical #1

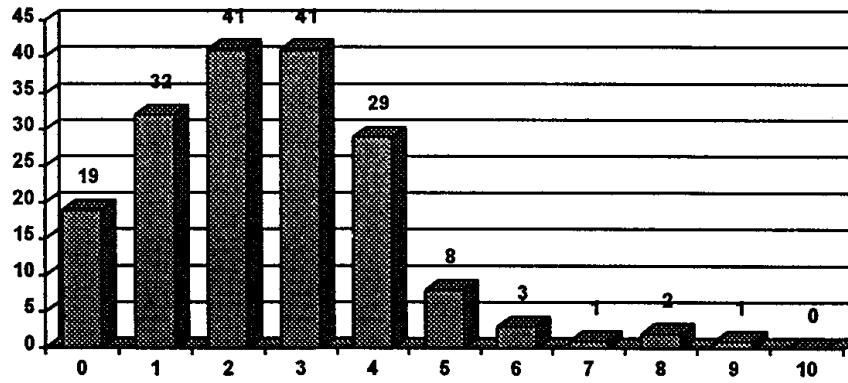

Theoretical #2

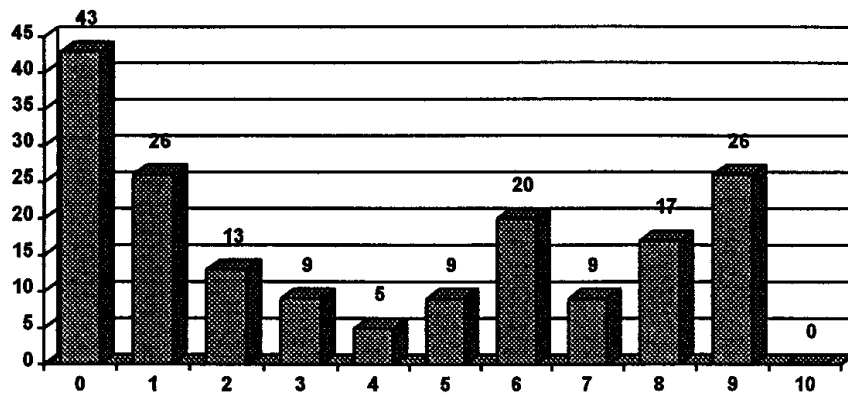

Theoretical #3

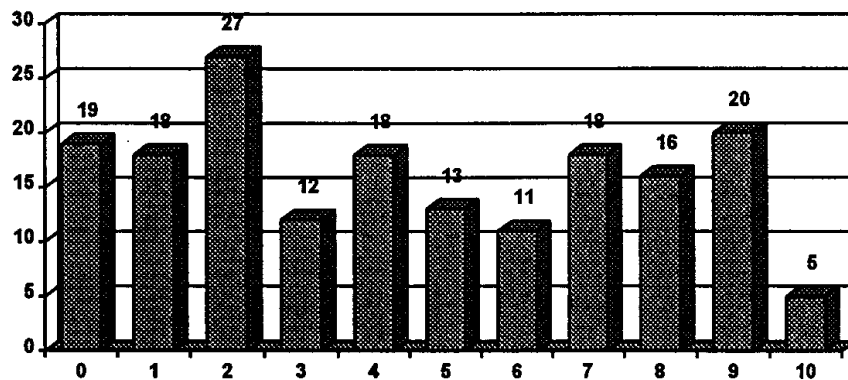

Helsinki-Espoo, Finland

July 5-13, 1992

Experimental #1

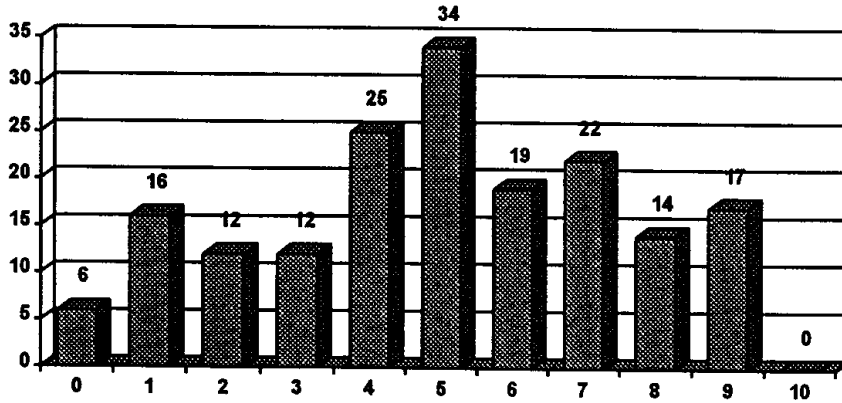

Experimental #2

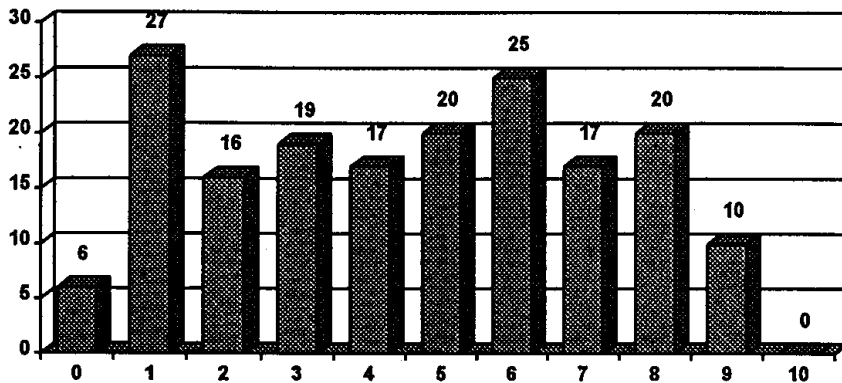

All problems

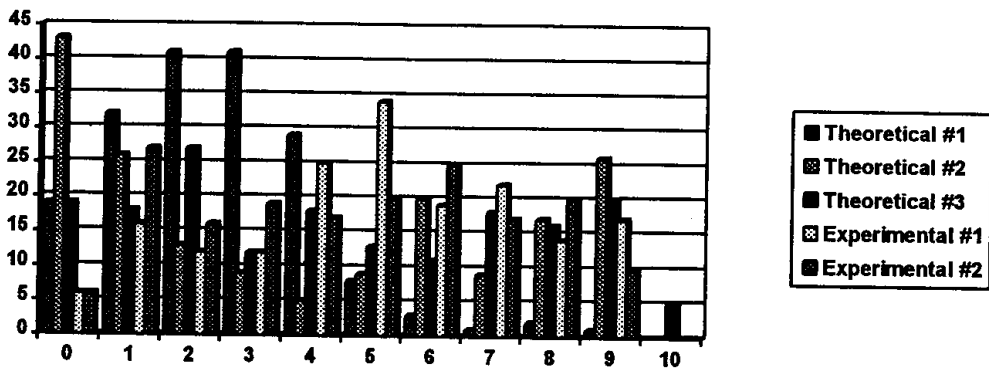

COUNTRY : _____

XXIV INTERNATIONAL PHYSICS OLYMPIAD

WILLIAMSBURG, VIRGINIA, U.S.A.

THEORETICAL COMPETITION

July 12, 1993

Time available: 5 hours

READ THIS FIRST!

INSTRUCTIONS:

1. Use only the pen provided.
2. Use only the marked side of the paper.
3. Begin each problem on a separate sheet.
4. Write at the top of each and every page:
 - The number of the problem
 - The number of the page of your solution in each problem
 - The total number of pages in your solution to the problem.

Example (for Problem 1): 1 1/4; 1 2/4; 1 3/4; 1 4/4.

General Tabulated Information

Quantity	Symbol	Value
Earth's mean radius	R_E	6.4×10^6 m.
acceleration due to gravity	g	9.8 m s ⁻² .
Newtonian gravitational constant	G	6.67×10^{-11} N m ² kg ⁻² .
permittivity of vacuum	ϵ_0	8.85×10^{-12} C ² N ⁻¹ m ⁻² .
permeability of vacuum	μ_0	8.85×10^{-7} N A ⁻² .
speed of light in vacuum (or air)	c	3.00×10^8 m s ⁻¹ .
elementary charge	e	1.60×10^{-19} C.
mass of electron	m_e	9.11×10^{-31} kg.
mass of proton	m_p	1.67×10^{-27} kg
Planck constant	h	6.63×10^{-34} J s.
Avogadro constant	N_A	6.02×10^{23} mol ⁻¹ .
Boltzmann constant	k	1.38×10^{-23} J K ⁻¹ .
molar gas constant	R	8.31 J mol ⁻¹ K ⁻¹ .

Theoretical Problem 1

ATMOSPHERIC ELECTRICITY

From the standpoint of electrostatics, the surface of the Earth can be considered to be a good conductor. It carries a certain total charge Q_0 and an average surface charge density σ_0 .

- 1) Under fair-weather conditions, there is a downward electric field, E_0 , at the Earth's surface equal to about 150 V/m. Deduce the magnitude of the Earth's surface charge density and the total charge carried on the Earth's surface.
- 2) The magnitude of the downward electric field decreases with height, and is about 100 V/m at a height of 100 m. Calculate the average amount of net charge per m^3 of the atmosphere between the Earth's surface and 100 m altitude.
- 3) The net charge density you have calculated in (2) is actually the result of having almost equal numbers of positive and negative singly-charged ions per unit volume (n_+ and n_-). Near the Earth's surface, under fair-weather conditions, $n_+ \approx n_- \approx 6 \times 10^8 m^{-3}$. These ions move under the action of the vertical electric field. Their speed is proportional to the field strength:

$$v \approx 1.5 \times 10^{-4} \cdot E,$$

where v is in m/s and E in V/m. How long would it take for the motion of the atmospheric ions to neutralize half of the Earth's surface charge, if no other processes (e.g. lightning) occurred to maintain it?

- 4) One way of measuring the atmospheric electric field, and hence σ_0 , is with the system shown in the diagram. A pair of metal quadrants, insulated from ground but connected to each other, are mounted just underneath a grounded uniformly rotating disk with two quadrant-shaped holes cut in it. (In the diagram, the spacing has been exaggerated in order to show the arrangement.) Twice in each revolution the insulated quadrants are completely exposed to the field, and then (1/4 of a period later) are completely shielded from it. Let T be the period of revolution, and let the inner and outer radii of the insulated quadrants be r_1 and r_2 as shown.

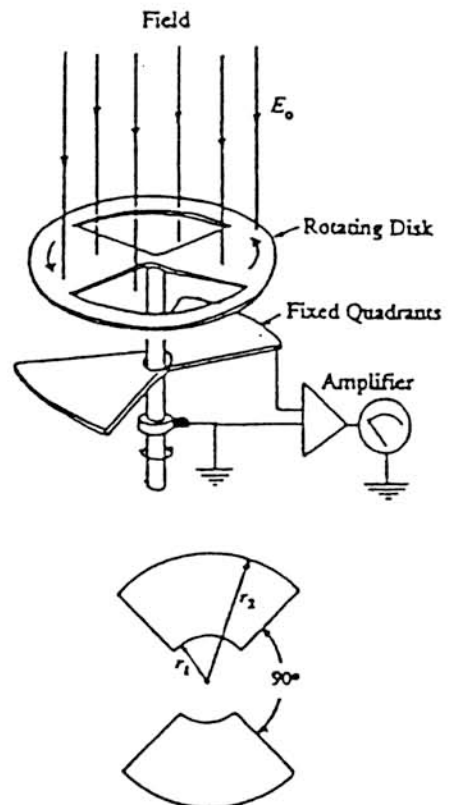

(Continued on next page)

Take $t = 0$ to be an instant when the insulated quadrants are completely shielded.

Obtain expressions that give the total charge $q(t)$ induced on the upper surface of the insulated quadrants as a function of time between $t = 0$ and $t = T/2$, and sketch a graph of this variation.

[The effects of the atmospheric ion current can be ignored in this situation.]

(5) The system described in (4) is connected to an amplifier whose input circuit is equivalent to a capacitor C and a resistor R in parallel. (You can assume that the capacitance of the quadrant system is negligible compared to C .) Sketch graphs of the form of the voltage difference V between the points M and N as a function of t during one revolution of the disk, just after it has been set into rotation with period of revolution T , if:

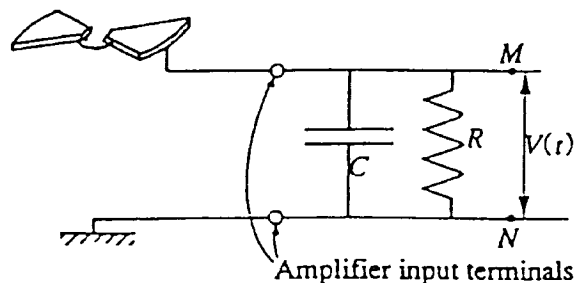

- a) $T = T_a \ll CR$;
- b) $T = T_b \gg CR$.

[Assume that C and R have fixed values; only T changes between situations (a) and (b).] Obtain an expression for the approximate ratio, V_a/V_b , of the largest values of $V(t)$ in cases (a) and (b).

6) Assume that $E_0 = 150 \text{ V/m}$, $r_1 = 1 \text{ cm}$, $r_2 = 7 \text{ cm}$, $C = 0.01 \text{ } \mu\text{F}$, $R = 20 \text{ M}\Omega$, and suppose that the disk is set into rotation at 50 revolutions per second.

Approximately, what is the largest value of V during one revolution in this case?

Theoretical Problem 1 -- Solution

1) By Gauss' law, $\sigma = \epsilon_0 E_0$.

$$\therefore \sigma = -8.85 \cdot 10^{-12} \times 150$$

$$\approx -1.3 \times 10^{-9} \text{ C/m}^2.$$

$$Q = 4\pi R^2 \sigma = 4\pi \times (6.4 \cdot 10^6)^2 \times 1.3 \cdot 10^{-9} = -6.7 \cdot 10^5 \text{ C.}$$

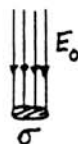

2) Consider a cylinder of cross-section A with faces at heights of 0 and 100 m.

$$\begin{aligned} \text{By Gauss' law, } E(0)A - E(100)A &= q_{\text{enclosed}}/\epsilon_0 \\ &= \rho_{\text{ave.}} \times (100A)/\epsilon_0. \end{aligned}$$

$$\begin{aligned} \therefore \rho_{\text{ave.}} &= \frac{\epsilon_0[E(0) - E(100)]}{100} \\ &= \frac{8.85 \cdot 10^{-12} \times 50}{100} \approx 4.4 \times 10^{-12} \text{ C/m}^3. \end{aligned}$$

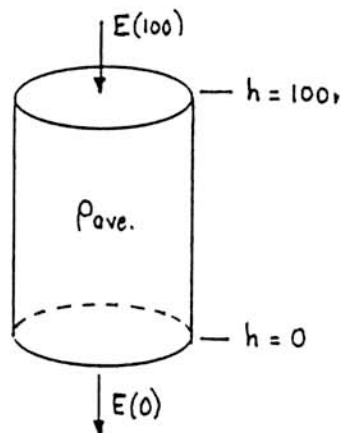

3) If a conductor contains n charges per unit volume, each with charge q and travelling with speed v , the current per unit area (j) is given by:

$$j = nqv.$$

Here, we have both positive and negative charges ($\pm e$). Clearly, with a downward electric field, the positive charges move downward and the negative charges move upward.

In the situation as described, only the positive charges can contribute to neutralization of the Earth's surface charge. Hence we have (taking downward as the positive direction for this purpose):

$$\begin{aligned} j &= n_+ e v \\ &\approx (6 \cdot 10^8) \times (1.6 \cdot 10^{-19}) \times (1.5 \cdot 10^{-4} E) \\ &= 1.44 \times 10^{-14} E. \end{aligned}$$

Now j is the rate of change ($d\sigma/dt$) of the surface charge density σ , and E (if defined as positive downward) is equal to $-\sigma/\epsilon_0$. Thus the above equation can be written:

$$\frac{d\sigma}{dt} = -1.44 \cdot 10^{-14} \frac{\sigma}{\epsilon_0} = -\frac{1.44 \cdot 10^{-14}}{8.85 \cdot 10^{-12}} \sigma = -1.63 \cdot 10^{-3} \sigma \approx -\frac{1}{600} \sigma.$$

This is just like the equation of radioactive decay. Its solution is an exponential decrease of σ with time:

$$\sigma(t) = \sigma_0 e^{-t/\tau}, \quad \text{with } \tau = 600 \text{ sec.}$$

Putting $\sigma(t) = \sigma_0/2$ then gives $t = \tau \ln 2 = 0.693 \times 600 \approx 415 \text{ sec} \approx 7 \text{ min.}$

[A simpler approximate solution is to assume that j remains constant at its initial value j_0 :

$$j_0 = 1.44 \cdot 10^{-14} E_0 = 1.44 \cdot 10^{-14} \times 150 \approx 2.15 \times 10^{-12} \text{ A/m}^2.$$

With $|\sigma_0| = 1.3 \cdot 10^{-9} \text{ C/m}^2$ from part 1, we would then put:

$$|\sigma_0/2| = j_0 \times t, \text{ giving } t = (0.65 \cdot 10^{-9}) / (2.15 \cdot 10^{-12}) \approx 300 \text{ s} = 5 \text{ min.}]$$

4) If $t = 0$ is an instant at which the insulated quadrants are completely shielded, we have the following relations:

$$\text{For } 0 \leq t \leq \frac{T}{4}, q(t) = -2\pi(r_2^2 - r_1^2)\epsilon_0 E_0 \frac{t}{T}.$$

$$\text{For } \frac{T}{4} < t \leq \frac{T}{2}, q(t) = -\pi(r_2^2 - r_1^2)\epsilon_0 E_0 \left(1 - \frac{2t}{T}\right).$$

Corresponding variations occur during all the succeeding pairs of quarter-cycles.

The maximum (negative) induced charge is given by:

$$q_{\max.} = -\frac{\pi}{2}(r_2^2 - r_1^2)\epsilon_0 E_0.$$

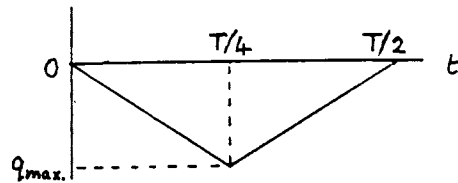

5) This question can be discussed without making a full circuit analysis. One only needs to realize that the rate of flow of charge into the amplifier is divided into a rate of charging of the capacitor, $C \, dV/dt$, and a conduction current, V/R , through the resistor. There are then two extreme situations, depending on whether the amount of charge lost by leakage during one quarter-period is small or large compared to CV .

(a) If $CV \gg (V/R) \times (T/4)$ -- i.e., $T = T_a \ll CR$ -- very little of the charge is carried away

through R during the time $T/4$. Thus, when the insulated quadrants are charged negatively through induction, an almost equal *positive* charge is given to C . Thus $V(t)$ rises almost linearly with t between $t = 0$ and $t = T/4$, and then decreases almost linearly by an equal amount between $t = T/4$ and $t = T/2$. In this case,

$$V_{\max.} = V_a \approx \frac{|q_{\max.}|}{C},$$

where $q_{\max.}$ has the value obtained in part 4.*

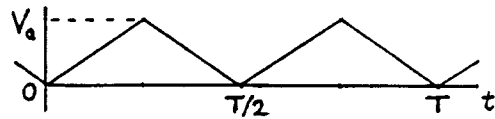

(b) If, however, $T = T_b \gg CR$ -- i.e., $CR \ll T_b$ -- most of the charge is quickly carried away through R . A constant positive current flows through R when the magnitude of q is increasing, and an equal negative current when the magnitude of q is decreasing. The size

*Note: Ultimately (unless CR is infinite) the form of V_a will become a sawtooth varying symmetrically between $\pm q_{\max.}/2C$. The statement of the problem avoids this complication by specifying that V is measured *just after* the rotation has begun.

of this current is approximately equal to $iq_{\max.}/(T_b/4)$. The resulting voltage across R is approximately constant during each quarter-period, and is alternately positive and negative. In this case,

$$V_{\max.} = V_b \approx \frac{4 q_{\max.} R}{T_b}$$

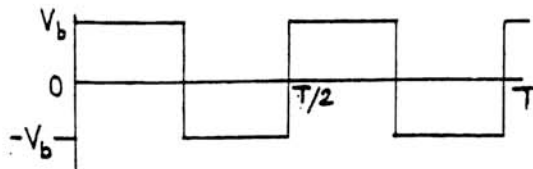

Putting these results together, we see that:

$$\frac{V_a}{V_b} \approx \frac{T_b}{4CR}$$

6) We have $CR = 10^{-8} \times 2 \cdot 10^7 = 0.2$ s, and $T = 1/50 = 0.02$ s.

Thus $CR = 10 \times T$, which satisfies the criterion $CR \gg T$.

Therefore we can use the solution 5(a) above.

We have $A_{\max.} = \frac{\pi}{2} (7^2 - 1^2) = 75 \text{ cm}^2 = 7.5 \times 10^{-3} \text{ m}^2$.

$E_o = 150 \text{ V/m} \rightarrow \sigma = \epsilon_o E_o \approx 1.33 \times 10^{-9} \text{ C/m}^2$ (as in part 1).

$\therefore q_{\max.} = 1.33 \cdot 10^{-9} \times 7.5 \cdot 10^{-3} \approx 1.0 \times 10^{-11} \text{ C}$,

and so $V_{\max.} = \frac{q_{\max.}}{C} = \frac{1.0 \times 10^{-11}}{1.0 \times 10^{-8}} = 10^{-3} \text{ V} = 1 \text{ mV}$.

Theoretical Problem 1: Grading Scheme

Part 1.	1 point	(1/2 point for σ_o , 1/2 point for Q)
Part 2.	1 point	
Part 3.	2 points	(1/2 point for recognizing $j = nev$; 1/2 point for recognizing $j = d\sigma/dt$; 1/2 point for getting $\sigma(t) = \sigma_o e^{-t/\tau}$; 1/2 point for final numerical answer.) [1 point maximum for using $t = \sigma_o/2j_o$.]
Part 4.	1-1/2 points	(1/2 point for each equation; 1/2 point for graph.)
Part 5.	3-1/2 points	(1 point for correct graphical form of (a); 1 point for correct graphical form of (b); 1-1/2 points for correct evaluation of V_d/V_b .)
Part 6.	1 point	(1/2 point for recognizing that $T \ll CR$; 1/2 point for final answer)

LASER FORCES ON A TRANSPARENT PRISM

By means of refraction a strong laser beam can exert appreciable forces on small transparent objects. To see that this is so, consider a small glass triangular prism with an apex angle $A = \pi - 2\alpha$, a base of length $2h$ and a width w . The prism has an index of refraction n and a mass density ρ .

Suppose that this prism is placed in a laser beam travelling horizontally in the x direction. (Throughout this problem assume that the prism does not rotate, i.e., its apex always points opposite to the direction of the laser beam, its triangular faces are parallel to the xy plane, and its base is parallel to the yz plane, as shown in Fig. 1.) Take the index of refraction of the surrounding air to be $n_{\text{air}} = 1$. Assume that the faces of the prism are coated with an anti-reflection coating so that no reflection occurs.

The laser beam has an intensity that is uniform across its width in the z direction but falls off linearly with distance y from the x axis such that it has a maximum value of I_0 at $y = 0$ and falls to zero at $y = \pm 4h$ (Fig. 2). [Intensity is power per unit area, e.g. expressed in W m^{-2} .]

- 1) Write equations from which the angle θ (see Fig. 3) may be determined (in terms of α and n) in the case when laser light strikes the upper face of the prism.

Fig. 1.

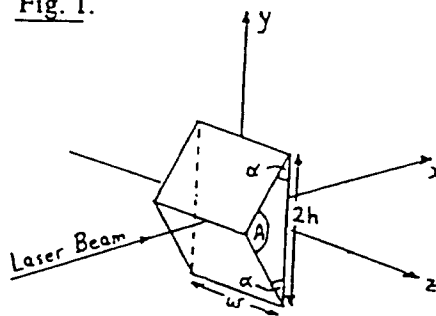

Fig. 2.

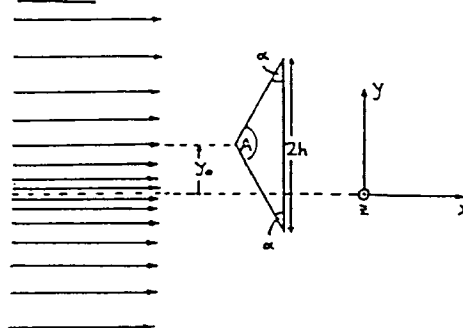
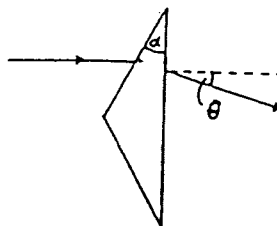

Fig. 3.



(Continued on next page)

-
- 2) Express, in terms of I_0 , θ , h , w and y_0 , the x and y components of the net force exerted on the prism by the laser light when the apex of the prism is displaced a distance y_0 from the x axis where $|y_0| \leq 3h$.
Plot graphs of the values of the horizontal and vertical components of force as functions of vertical displacement y_0 .
- 3) Suppose that the laser beam is 1 mm wide in the z direction and $80 \mu\text{m}$ thick (in the y direction). The prism has $\alpha = 30^\circ$, $h = 10 \mu\text{m}$, $n = 1.5$, $w = 1 \text{ mm}$ and $\rho = 2.5 \text{ g cm}^{-3}$. How many watts of laser power would be required to balance this prism against the pull of gravity (in the $-y$ direction) when the apex of the prism is at a distance $y_0 = -h/2 (= -5 \mu\text{m})$ below the axis of the laser beam?
- 4) Suppose that this experiment is done in the absence of gravity with the same prism and a laser beam with the same dimensions as in (3), but with $I_0 = 10^8 \text{ W m}^{-2}$. What would be the period of oscillations that occur when the prism is displaced and released a distance $y = h/20$ from the center line of the laser beam?

Theoretical Problem 2 -- Solution

1. This is a simple problem in geometry and Snell's Law

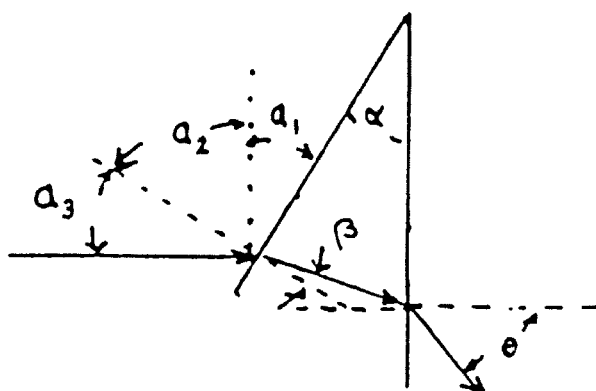

Figure 1: Refraction through a wedge.

The angle of incidence $\alpha_3 = \alpha$ because $\alpha_1 = \alpha$ and $\alpha_1 + \alpha_2 = \alpha_2 + \alpha_3 = 90^\circ$. The angle β is found from Snell's law $\sin \alpha = n \sin \beta$. The angle of incidence on the base is

$$\frac{\pi}{2} - (\pi - \alpha - (\frac{\pi}{2} - \beta)) = \alpha - \beta$$

from which it follows that

$$\sin \theta = n \sin(\alpha - \beta)$$

implying that

$$\theta = \sin^{-1} \left[n \sin \left(\alpha - \sin^{-1} \left(\frac{\sin \alpha}{n} \right) \right) \right]$$

2. The force on the prism is equal and opposite to the rate of change of momentum of the laser light passing through it. To analyze this, consider the momentum changes of the laser light incident on the upper half of the prism.

Think of the laser beam as delivering to the upper half of the prism r_u photons per second parallel to the x axis. If the energy of a photon is E , then its momentum is $\vec{p}_i = \frac{E}{c} \hat{i}$, and a photon leaving the prism at an angle θ to the x axis will differ in momentum from the incident photon by

$$\delta \vec{p} = \frac{E}{c} (\cos \theta - 1) \hat{i} - \frac{E}{c} \sin \theta \hat{j}.$$

The rate of change of momentum of these photons will then be

$$\vec{F}_{up} = r_u \delta \vec{p} = \frac{r_u E}{c} [(\cos \theta - 1) \hat{i} - \sin \theta \hat{j}.]$$

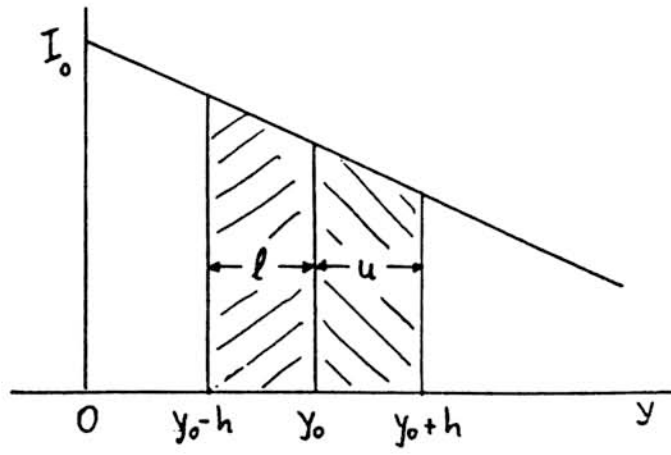

Figure 2: \bar{I}_u and \bar{I}_l when $y_0 \geq h$

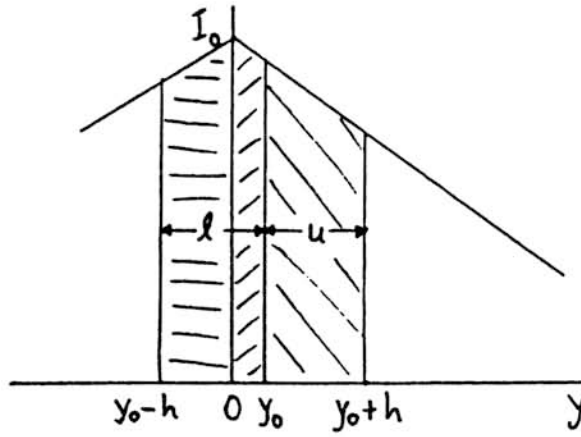

Figure 3: \bar{I}_u and \bar{I}_l when $0 < y_0 < h$

The quantity $r_u E$ is the power P_u delivered to the upper face, and the recoil force \vec{F}_u produced by light refracting through the upper half of the prism will be

$$\vec{F}_u = \frac{P_u}{c} [(1 - \cos \theta) \hat{i} + \sin \theta \hat{j}].$$

A similar argument gives the force on the lower half as

$$\vec{F}_l = \frac{P_l}{c} [(1 - \cos \theta) \hat{i} - \sin \theta \hat{j}].$$

From these two results we see that the net force on the prism will be

$$\vec{F} = \frac{1}{c} [(P_u + P_l)(1 - \cos \theta)] \hat{i} + \frac{1}{c} [(P_u - P_l) \sin \theta] \hat{j}.$$

The angle θ can be expressed in terms of α (see answer to part 1).

To find the values of P_u and P_l calculate the average intensities, \bar{I}_u and \bar{I}_l , incident on each half of the prism and multiply by hw , the area of each half of the prism projected perpendicular to the laser beam. Because the intensity distribution $I(y)$ is a linear function of y , the average intensities are easily determined.

The problem states that

$$\begin{aligned} I(y) &= I_0 \left(1 - \frac{y}{4h}\right) && \text{for } 0 < y < +4h \\ &= I_0 \left(1 + \frac{y}{4h}\right) && \text{for } -4h < y < 0. \end{aligned}$$

Now suppose that the prism is lifted a distance y_0 from the x axis ($y_0 > 0$). There are two distinct cases:

- (a) When $h \leq y_0 \leq 3h$, the whole prism is entirely in the upper half of the beam. As Fig. 2 shows, for this case the average is equal to the intensity at the center of each face which is at $y_0 + h/2$ for the upper face and at $y_0 - h/2$ for the lower one. This gives

$$\begin{aligned} \bar{I}_u &= I_0 \left(1 - \frac{y_0 + h/2}{4h}\right) = I_0 \left(\frac{7}{8} - \frac{y_0}{4h}\right) \\ \bar{I}_l &= I_0 \left(1 - \frac{y_0 - h/2}{4h}\right) = I_0 \left(\frac{9}{8} - \frac{y_0}{4h}\right) \end{aligned}$$

From these it follows that

$$\begin{aligned} F_x &= \frac{2hwI_0}{c} \left(1 - \frac{y_0}{4h}\right) (1 - \cos \theta) \\ F_y &= -\frac{hwI_0}{4c} \sin \theta. \end{aligned}$$

- (b) When $0 < y_0 < h$, the lower half of the prism is partly in the lower half of the laser beam as shown in Fig. 3. Then the part of the lower half of the prism between 0 and y_0 has a fraction y_0/h of the area of the lower half of the prism and sees an average intensity

$$\bar{I}_{l_1} = I(y_0/2) = I_0 \left(1 - \frac{y_0}{8h} \right).$$

The part between 0 and $y_0 - h$ has a fraction $1 - y_0/h$ of the area and sees an average intensity of

$$\bar{I}_{l_2} = I\left(\frac{h - y_0}{2}\right) = I_0 \left(\frac{7}{8} + \frac{y_0}{8h} \right).$$

Putting these together we get

$$\begin{aligned} P_l &= hw \frac{y_0}{h} \bar{I}_{l_1} + hw \left(1 - \frac{y_0}{h} \right) \bar{I}_{l_2} \\ &= hw I_0 \left(\frac{7}{8} + \frac{y_0}{4h} - \frac{y_0^2}{4h^2} \right). \end{aligned}$$

The average intensity on the upper face has the same functional dependence on y_0 as in the first case. Therefore, $P_u = hw I_0 \left(\frac{7}{8} - \frac{y_0}{4h} \right)$ as before.

Putting these together gives

$$\begin{aligned} P_u + P_l &= hw I_0 \left(\frac{7}{4} - \frac{y_0^2}{4h^2} \right) \\ P_u - P_l &= -hw I_0 \frac{y_0}{2h} \left(1 - \frac{y_0}{2h} \right) \end{aligned}$$

from which it follows that

$$\begin{aligned} F_x &= \frac{hw I_0}{c} \left(\frac{7}{4} - \frac{y_0^2}{4h^2} \right) (1 - \cos \theta) \\ F_y &= -\frac{hw I_0}{c} \frac{y_0}{2h} \left(1 - \frac{y_0}{2h} \right) \sin \theta. \end{aligned}$$

Because the intensity distribution is symmetric about the axis of the laser beam, the solutions for $y_0 < 0$ will mirror the solutions for $y_0 > 0$. Graphs of the F_x and F_y as functions of y_0 are shown in Fig. 4.

3. Both the equation and the graph of F_y show that to have $F_y > 0$ and opposite the force of gravity, y_0 must be < 0 . Then to find the force necessary to support the prism against gravity, find the prism's mass, and equate the expression for the vertical component of force from the laser beam to the weight of the prism, and find I_0 for the parameters given. Use that result to find the total power in the laser beam. This

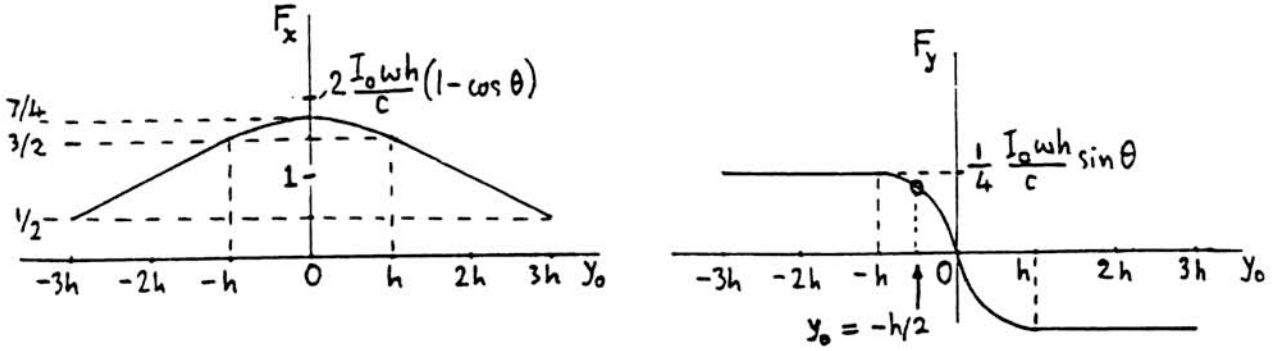

Figure 4: (a) F_x vs y_0 ; (b) F_y vs y_0

can be done by finding the average value \bar{I} over the specified cross sectional area of the laser beam.

To find the mass of the prism first find its volume = $\tan \alpha h^2 w$ then

$$\begin{aligned}
 m &= \frac{1}{\sqrt{3}} \times (10^{-3})^2 \times .1 \times 2.5 \\
 &= 1.44 \times 10^{-7} \text{ g} \\
 &= 1.44 \times 10^{-10} \text{ kg;} \\
 mg &= 1.42 \times 10^{-9} \text{ N}
 \end{aligned}$$

The solution to (2) assumed a displacement in the $y > 0$ direction, but the problem is symmetric so we can use that solution. We want the value of I_0 that satisfies

$$\frac{I_0 h w}{c} \frac{y_0}{2h} \left(1 - \frac{y_0}{2h}\right) \sin \theta = mg = 1.42 \times 10^{-9}$$

when

$$\begin{aligned}
 \theta &= 15.9^\circ \\
 y_0 &= \frac{h}{2} \\
 h &= 10 \times 10^{-6} \text{ m} \\
 w &= 10^{-3} \text{ m}
 \end{aligned}$$

$$I_0 = \frac{3 \times 10^8 \times 1.42 \times 10^{-9}}{10^{-5} \times 10^{-3} \times .274 \times \frac{3}{16}} = 8.30 \times 10^8 \text{ W/m}^2$$

since the power P is given by $P = \bar{I} \times \text{area of laser beam}$ where $\bar{I} = \frac{I_0}{2}$. This yields

$$P = \frac{1}{2} \times 8.30 \times 10^8 \times 10^{-3} \times 80 \times 10^{-6} = 33.2 \text{ W.}$$

4. A displacement of $h/20$ corresponds to $y_0/h = .05 \ll 1$ so that the vertical force component is well approximated by

$$F_y = -\frac{I_0 w \sin \theta}{2c} y.$$

This is the equation of a harmonic oscillator with angular frequency

$$\omega = \sqrt{\frac{I_0 w \sin \theta}{2mc}} = \sqrt{\frac{I_0 \sin \theta}{2c\rho h^2 \tan \alpha}}.$$

Putting numbers into this gives

$$T = \frac{2\pi}{\omega} = 2\pi \sqrt{\frac{2 \times 3 \times 10^8 \times 2.5 \times 10^3 \times 10^{-10} \times 1/\sqrt{3}}{10^8 \times .274}} = 11.2 \times 10^{-3} \text{ s.}$$

Theoretical Problem 2: Grading Scheme

Part 1. 1.5 points

Part 2. 5 points (2 points for obtaining expression for net force in terms of θ and powers P_u, P_l incident on upper and lower prism faces ;
1 point for finding F_x and F_y explicitly in terms of I_0, y_0 and θ for $h \leq y_0 \leq 3h$;
1 point for finding F_x and F_y explicitly in terms of I_0, y_0 and θ for $0 \leq y_0 \leq h$;
1 point for drawing appropriate graphs)

Part 3. 1.5 points

Part 4. 2 points

Theoretical Problem 3

ELECTRON BEAM

An accelerating voltage V_0 produces a uniform, parallel beam of energetic electrons. The electrons pass a thin, long, positively charged copper wire stretched at right angles to the original direction of the beam, as shown in the figure. The symbol b denotes the distance at which an electron would pass the wire if the wire were uncharged. The electrons then proceed to a screen (viewing surface) a distance L ($\gg b$) beyond the wire, as shown. The beam initially extends to distances $\pm b_{\max}$ with respect to the axis of the wire. Both the width of the beam and the length of the wire may be considered infinite in the direction perpendicular to the paper.

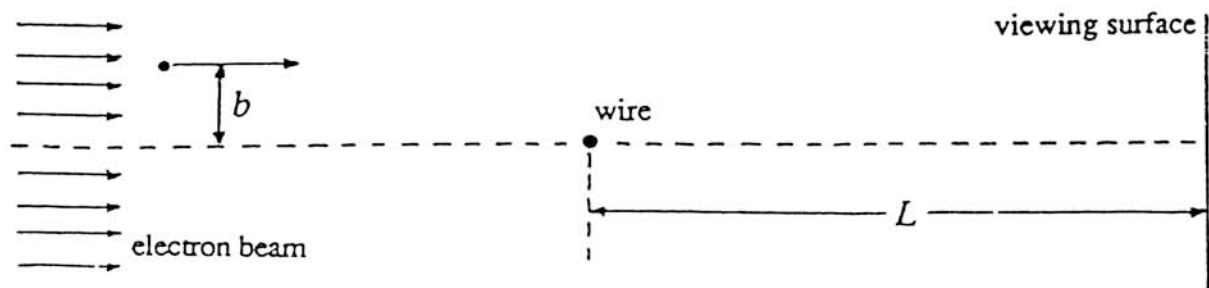

The charged wire extends perpendicularly to the plane of the paper. The sketch is not to scale.

Some numerical data are provided here; you will find other numerical data in the table at the front of the examination:

$$\text{radius of wire} = r_0 = 10^{-6} \text{ m}$$

$$\text{maximum value of } b = b_{\max} = 10^{-4} \text{ m}$$

$$\text{electric charge per unit length of wire} = q_{\text{linear}} = 4.4 \times 10^{-11} \text{ C m}^{-1}$$

$$\text{accelerating voltage} = V_0 = 2 \times 10^4 \text{ V}$$

$$\text{length from wire to observing screen} = L = 0.3 \text{ m.}$$

Note: For parts 2 - 4, make reasonable approximations that lead to analytical and numerical solutions.

- 1) Calculate the electric field \mathbf{E} produced by the wire. Sketch the magnitude of \mathbf{E} as a function of distance from the axis of the wire.

(Continued on next page)

-
- 2) Use classical physics to calculate the angular deflection of an electron. Do this for values of the parameter b such that the electron does not strike the wire. Let θ_{final} denote the (small) angle between the initial velocity of the electron and the velocity when the electron reaches the viewing surface. Hence, calculate θ_{final} .
- 3) Calculate and sketch the pattern of impacts (i.e., the intensity distribution) on the viewing screen that classical physics predicts.
- 4) Quantum physics predicts a major difference in the intensity distribution (relative to what classical physics predicts). Sketch the pattern for the quantum prediction and provide quantitative detail.

Theoretical Problem 3 -- Solution

1. By symmetry, the electric field will point radially away from the wire, and its magnitude will depend only on the radius r (in cylindrical coordinates). Place an imaginary cylinder around the wire and use Gauss's law:

$$2\pi rE(r) = \frac{q_{\text{linear}}}{\epsilon_0}$$

for a cylinder of radius r and unit length, provided $r \geq r_0$. Therefore

$$E(r) = \frac{q_{\text{linear}}}{2\pi r\epsilon_0} = \frac{0.791}{r} \text{ N/C} \quad \text{provided } r \geq r_0.$$

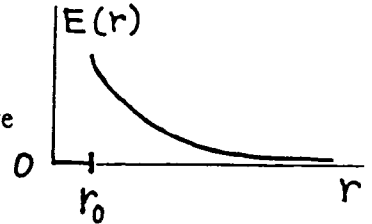

When $r < r_0$, the electric field is zero (because copper is a good conductor), that is, the electric field is zero inside the wire.

2. The problem stated that the angular deflection is small. Estimate the deflection angle θ_{final} by forming a quotient: the momentum acquired transverse to the initial velocity divided by the initial momentum:

$$\theta_{\text{final}} \cong \frac{|\Delta p_{\perp}|}{mv_0}$$

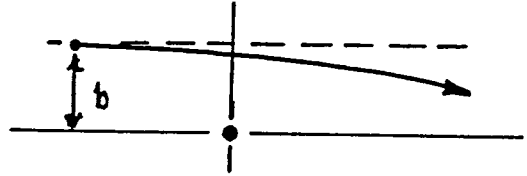

A first estimate of the transverse momentum can be made as follows:

The transverse force (where it is significant) is of order $\frac{eq_{\text{linear}}}{2\pi\epsilon_0 b}$.

The (significant) transverse force operates for a time such that the electron goes a distance of order $2b$, and hence that transverse force operates for a time of order $2b/v_0$.

The product of force and operating time gives an estimate the transverse momentum:

$$|\Delta p_{\perp}| \cong \frac{eq_{\text{linear}} 2b}{2\pi\epsilon_0 b v_0} = \frac{eq_{\text{linear}}}{\pi\epsilon_0 v_0},$$

and so $\theta_{\text{final}} \cong \frac{eq_{\text{linear}}}{\pi\epsilon_0 m v_0^2} = \frac{q_{\text{linear}}}{\pi\epsilon_0 2V_0} = 3.96 \times 10^{-5}$ radians

after one uses energy conservation to say $\frac{1}{2}mv_0^2 = eV_0$. Note that the deflection is extremely small and that the deflection is independent of the impact parameter b . Because the force between the positively charged wire and the electron is attractive, the deflection will bend the trajectory toward the wire—though only ever so slightly.

A more accurate estimate can be made by setting up an elementary integration for $|\Delta p_{\perp}|$, as follows. For the sake of the integration, approximate the actual trajectory by a straight line that passes the wire at distance b , as shown in the sketch.

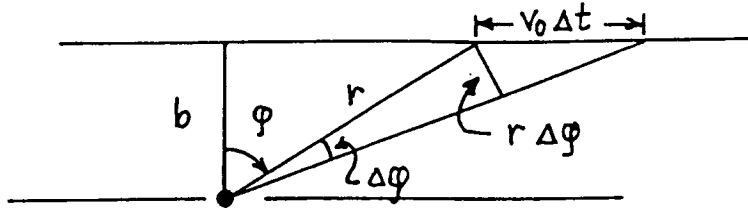

$$|F_{\perp}| = \frac{eq_{\text{linear}}}{2\pi\epsilon_0 r} \cos \varphi \quad v_0 \Delta t \cos \varphi = r \Delta \varphi \quad \text{and so} \quad \Delta t = \frac{r \Delta \varphi}{v_0 \cos \varphi}$$

$$|F_{\perp}| \Delta t = \frac{eq_{\text{linear}}}{2\pi\epsilon_0 r} \cos \varphi \frac{r \Delta \varphi}{v_0 \cos \varphi} = \frac{eq_{\text{linear}}}{2\pi\epsilon_0 v_0} \Delta \varphi.$$

Adding up the increments in $\Delta \varphi$ over the range $-\pi/2$ to $\pi/2$ yields $|\Delta p_{\perp}| = \frac{eq_{\text{linear}}}{2\epsilon_0 v_0}$.

The better estimate differs from the first estimate by merely the factor $\frac{\pi}{2}$. The better estimate yields

$$\theta_{\text{final}} \equiv \frac{eq_{\text{linear}}}{2\epsilon_0 m v_0^2} = \frac{q_{\text{linear}}}{2\epsilon_0 2V_0} = 6.21 \times 10^{-5} \text{ radians.}$$

3. Most of the bending of the trajectory occurs within a distance from the wire of order b . On the scale of L , order b is very small indeed. Therefore we may approximate the trajectory by two straight lines with a kink near the wire. Thus, at the viewing surface, the transverse displacement of each trajectory is

$$\left(\begin{array}{c} \text{transverse} \\ \text{displacement} \end{array} \right) = \theta_{\text{final}} L = 6.21 \times 10^{-5} \times 0.3 = 1.86 \times 10^{-5} \text{ meter} \approx 19 r_0 \gg r_0.$$

Thus the portions of the beam that pass on opposite sides of the wire have a region of overlap, as shown in the sketch.

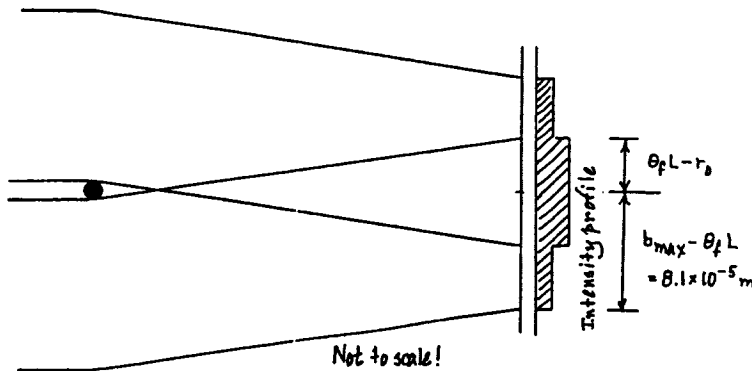

The full width of the overlap region is

$$\left(\begin{array}{c} \text{full} \\ \text{width} \end{array} \right) = 2 \times (\theta_{\text{final}} L - r_0) \cong 36 r_0 = 36 \times 10^{-6} \text{ meter.}$$

The density of impacts is constant within each region and doubled in the overlap region.

4. Associated with the electron beam is a quantum wave pattern whose de Broglie wavelength is

$$\lambda = \frac{h}{mv_0} = \frac{h}{\sqrt{2meV_0}} = 8.68 \times 10^{-12} \text{ meter.}$$

The de Broglie wavelength is so much smaller than the beam width $2b_{\text{max}}$ that one may ignore "single slit diffraction" effects. Rather, to the right of the wire, two plane waves that travel at a fixed angle relative to each other (an angle $2\theta_{\text{final}}$) overlap and interfere. In the region where, classically, the two halves of the original beam overlap, there will be interference maxima and minima.

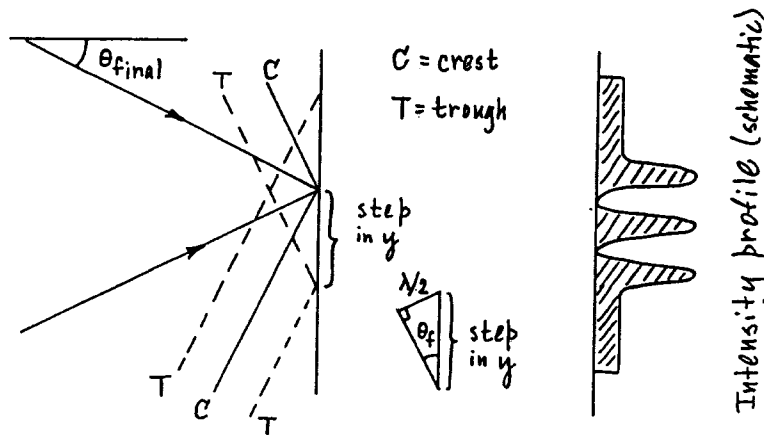

Reference to the sketch indicates that

$$\left(\begin{array}{c} \text{Interval between} \\ \text{adjacent constructive} \\ \text{interference locations} \end{array} \right) = \left(\begin{array}{c} \text{step} \\ \text{in } y \end{array} \right) = \frac{\lambda/2}{\sin \theta_{\text{final}}} \cong \frac{\lambda/2}{\theta_{\text{final}}} \cong \frac{\frac{1}{2} \times 8.68 \times 10^{-12}}{6.21 \times 10^{-5}} = 7.00 \times 10^{-8} \text{ meter.}$$

Because the region of overlap has a full width of $\cong 36 \times 10^{-6}$ meter, there will be roughly 500 interference maxima. Note that the interval between adjacent maxima does *not* depend on either b or b_{max} (unlike the situation with ordinary "double slit interference").

Historical note. This problem is based on the now-classic experiment by G. Mollenstedt and H. Duker, "Observation and Measurement of Biprism Interference with Electron Waves," *Zeitschrift für Physik*, 145, pp. 377-397 (1956).

Theoretical Problem 3: Grading Scheme

Part 1. 1 point.

E(r) correct outside of wire: 1 point.

E(r) inside wire: ignore in the grading. (Some students may ignore the interior because there is no field there.)

Part 2. 5 points, distributed as follows:

θ_{final} independent of b : 1 pt.

$\theta_{\text{final}} \propto \frac{eq_{\text{linear}}}{\epsilon_0 m v_0^2}$ or $\frac{q_{\text{linear}}}{\epsilon_0 V_0}$ or equivalent: + 1 pt.

Numerical coefficient correct to within a factor of 4: + 2 pts.

Numerical coefficient correct to within 20 %: + 1 pt.

Part 3: 1.5 points:

Overlap region exists: 0.5 pt.

Constant densities of impacts within each region: + 0.25 pt.

Correct ratio of intensities: + 0.25 pt.

Full width of pattern correct, given student's value for θ_{final} : + 0.25 pt.

Width of overlap region correct, given student's value for θ_{final} : + 0.25 pt.

Part 4: 2.5 points:

Recognizes that "two wave" interference occurs: 0.5 pt.

Correct de Broglie wavelength : 0.5 pt.

Correct separation of maxima: + 1.5 pts.

[If separation of maxima is wrong by merely a factor of 2, then partial credit: +1 pt.]

Maxima in intensity = 4 times single-wave intensity: ignore in grading.

COUNTRY : _____

XXIV INTERNATIONAL PHYSICS OLYMPIAD
WILLIAMSBURG, VIRGINIA, U.S.A.

PRACTICAL COMPETITION
Experiment No. 1

July 14, 1993

Time available: 2.5 hours

READ THIS FIRST!

INSTRUCTIONS:

1. Use only the pen provided.
2. Use only the marked side of the paper.
3. Write at the top of each and every page:
 - The number of the problem
 - The number of the page of your report
 - The total number of pages in your report.

Example (for Problem 1): 1 1/4; 1 2/4; 1 3/4; 1 4/4.

Experimental Problem 1

THE HEAT OF VAPORIZATION OF NITROGEN

The object of this experiment is to measure the heat of vaporization per unit mass (L) of nitrogen using two different methods. In Method #1, you will add a piece of aluminum to the sample of liquid nitrogen and measure how much liquid nitrogen evaporates as the aluminum cools. In Method #2, you will add energy in the form of heat at a known rate to the sample of liquid nitrogen and measure the rate at which the liquid nitrogen vaporizes.

The liquid nitrogen is supplied to you in the “reservoir” container. Some of it can be poured into the “sample” container, which can be placed on the mass balance. The reading of the mass balance will decrease as liquid nitrogen vaporizes. This occurs (1) because the container is not a perfect insulator, (2) because energy is being added to the liquid nitrogen in the form of heat when the aluminum cools (in Method #1), and (3) because energy is being added to the liquid nitrogen in the form of heat when current passes through a resistor placed in the liquid nitrogen (in Method #2). A multimeter, which can be used to measure voltage (V), current (I), and resistance (R), as well as a stopwatch are supplied. Instructions for using the multimeter and stopwatch are attached.

Warnings

- (1) **Liquid nitrogen is very cold, so do not let it, or any object which has been cooled by it, touch you or your clothing in any way.**
- (2) **Do not drop anything in the liquid nitrogen, and wear safety goggles at all times.**
- (3) **Place the piece of aluminum in the liquid nitrogen slowly, as it will cause the liquid nitrogen to boil rapidly until equilibrium is reached. A piece of string is supplied for this purpose.**
- (4) **The resistor can get very hot if it is not immersed in the liquid nitrogen. Pass current through the resistor only when it is in the container and completely immersed in liquid nitrogen.**

Method #1

The specific heat of aluminum (c) varies significantly between room temperature and the temperature at which liquid nitrogen vaporizes under atmospheric pressure (77 K). A graph showing the variation of c with temperature (T) is attached. Conduct an experiment to measure how much liquid nitrogen vaporizes when the aluminum block is cooled. Use this determination and the specific heat graph to determine the heat of vaporization per unit mass of nitrogen. You may assume that room temperature is $21 \pm 2^\circ\text{C}$. Be sure to provide a quantitative estimate of the accuracy of your heat of vaporization value.

Method #2

Conduct an experiment to measure the rate at which liquid nitrogen vaporizes when current is passed through the resistor placed in the liquid nitrogen. A direct current power supply is provided; use it only with the dial in the “8” position and do not disconnect the

capacitor installed across its terminals. Use this result to determine the heat of vaporization per unit mass of nitrogen. Be sure to provide a quantitative estimate of the accuracy of your result.

Notes:

- (1) Please include sketches, schematic diagrams, properly labelled tables, numbers with the proper units, etc. so the graders can determine exactly what you did.
- (2) Ask for assistance if any piece of equipment is not working properly.

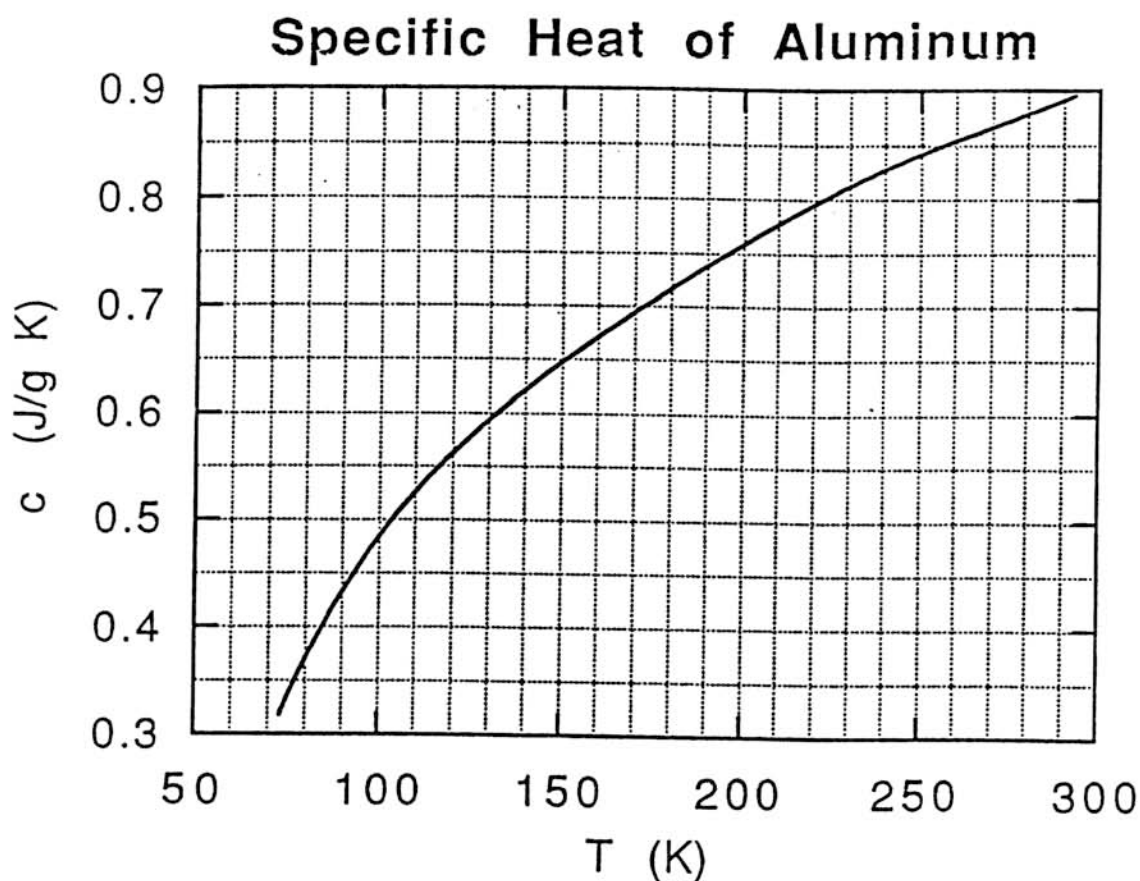

Digital Stopwatch

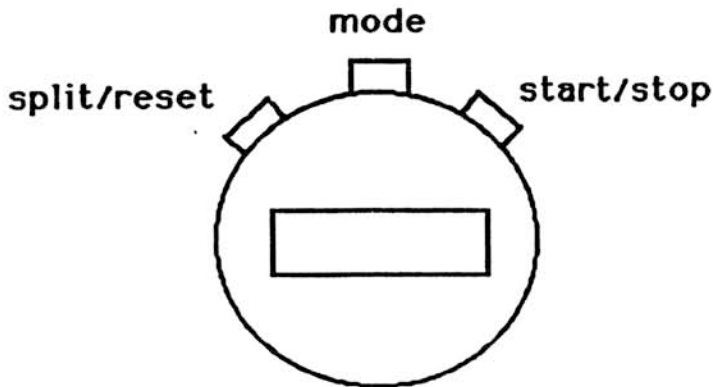

To Perform Timing Operations

1. Press "Mode" until 0 00 00 appears
(You may have to press "Mode" several times to get the 0 00 00 to appear)

To Time a Single Interval

1. Press "Start/Stop" to start stopwatch.
2. Press "Start/Stop" to stop stopwatch.
3. Press "Split/Reset" to reset stopwatch to zero.

To Time Multiple Events Without Stopping the Stopwatch

1. Press "Start/Stop" to start stopwatch.
2. Press "Split/Reset" to stop the display while stopwatch keeps running.
3. Press "Split/Reset" to reset display to actual time.
4. Press "Start/Stop" to stop stopwatch after last event.
5. Press "Split/Reset" to reset stopwatch to zero.

Multimeter

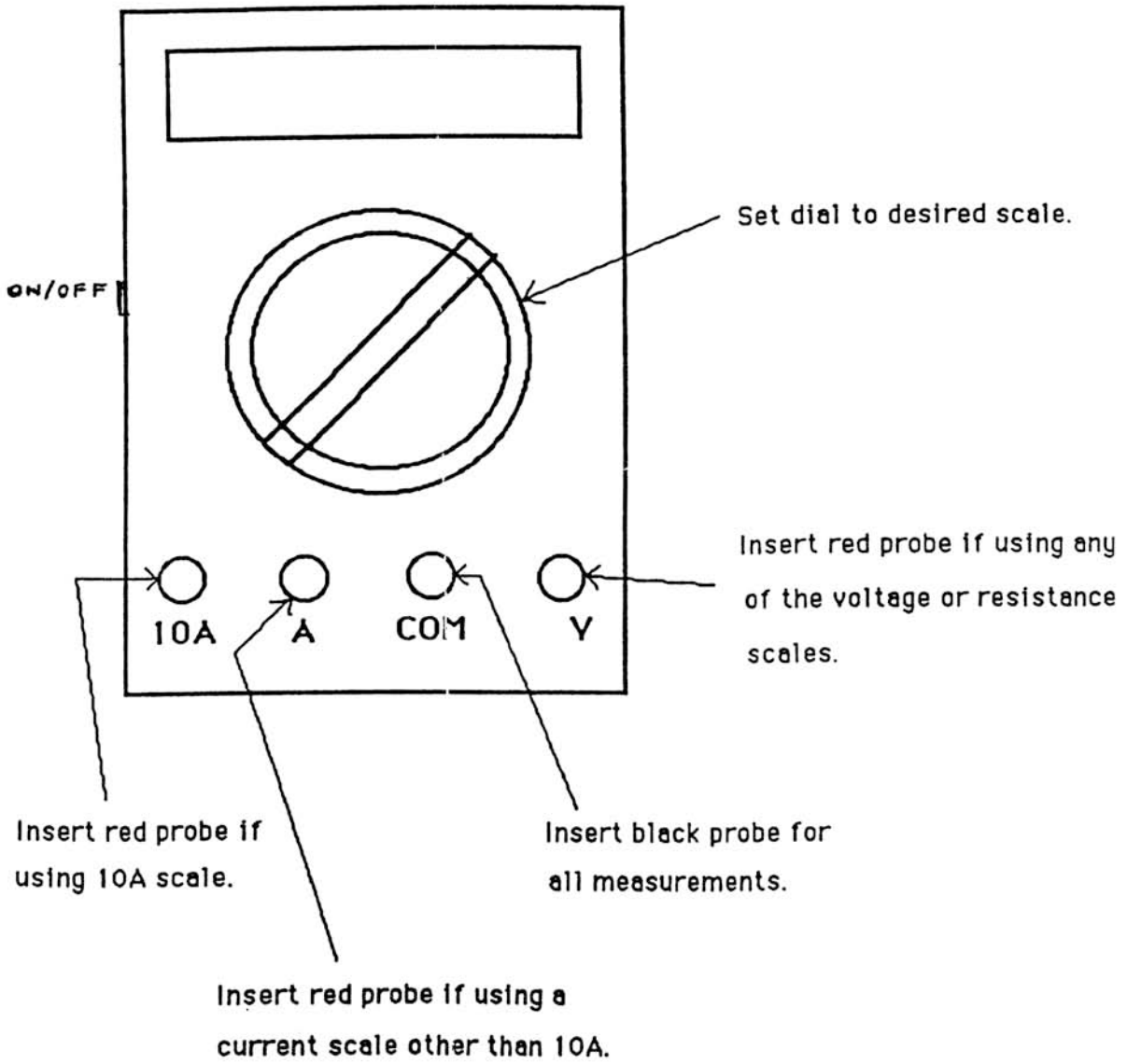

Experimental Problem 1 -- Solutions

Method #1

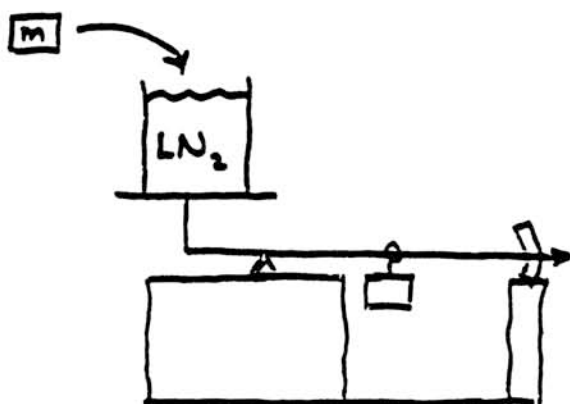

$$Q = mc\Delta T = m \int c dT$$

$$Q = L \Delta M_{LN_2}$$

$$m = 19.4 \pm 0.1 \text{ g}$$

	<u>total mass</u>	<u>clock time</u>	<u>time</u>
	153 g	0:00.0	0
	152	0:36.8	36.8
	151	1:19.1	79.1
	150	2:00.7	120.7
	149	2:40.5	160.5
	148	3:23.1	203.1
Add Al mass			
	150 (130.6)	5:31.8	331.8
	149 (129.6)	6:21.6	381.6
	148 (128.6)	7:17.3	457.3
	147 (127.6)	8:08.6	488.6
	146 (126.6)	9:00.9	540.9
	145 (125.6)	9:54.6	594.6

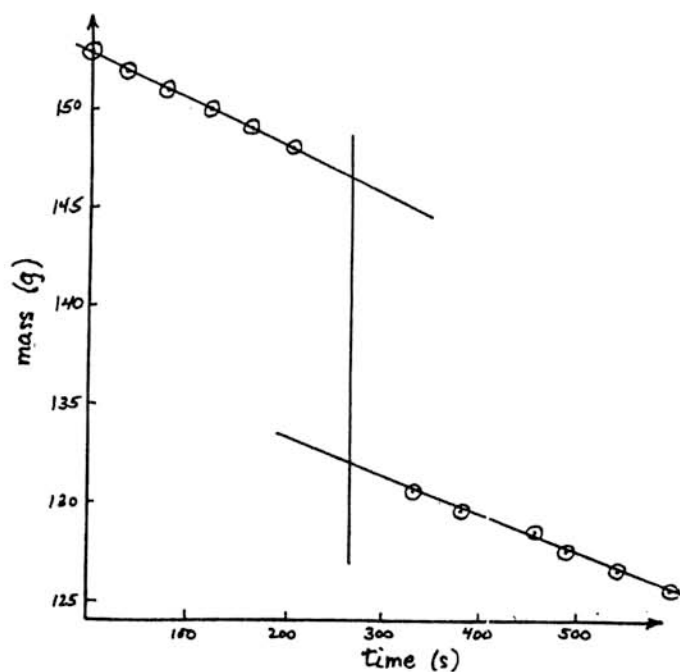

$$\begin{aligned} \Delta M_{LN_2} &= 146.5 - 132.0 \\ &= 14.5 \pm 0.3 \text{ g} \end{aligned}$$

Specific Heat of Aluminum

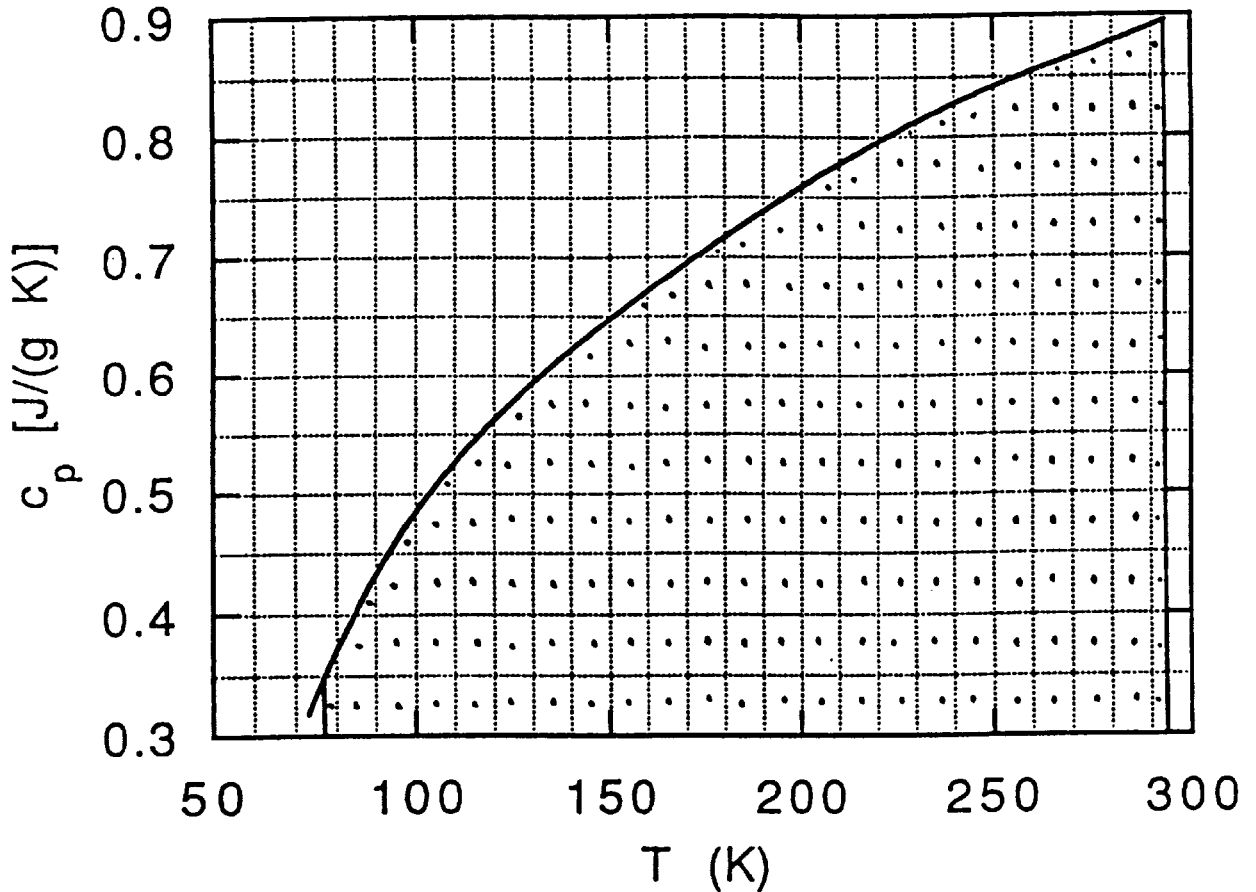

$$\int_{77}^{293} c \, dT \approx (0.3)(293 - 77) + (173)(0.5)$$

$$\approx 64.8 + 86.5 = 151 \pm 2 \text{ J/g}$$

$$Q = \int m c \, dT = (19.4 \pm 0.1 \text{ g})(151 \pm 2 \text{ J/g})$$

$$= 2930 \pm 42 \text{ J.}$$

$$L = \frac{Q}{\Delta M_{\text{LN}_2}} = \frac{2930 \pm 42 \text{ J}}{14.5 \pm 0.3 \text{ g}} = 202 \pm 5 \text{ J/g}$$

Method #2

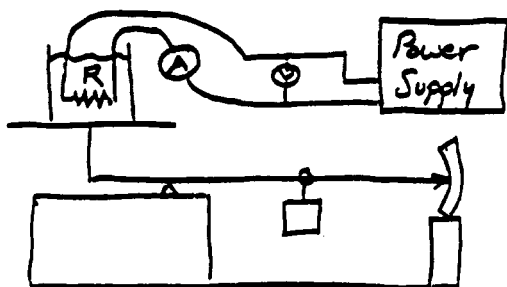

$$P = IV = V^2/R = I^2R$$

$$P = \Delta Q/\Delta t$$

$$Q = M_{LN_2}L$$

$$R = 23.0 \Omega \text{ (in LN}_2\text{)}$$

$$V = 12.7 \text{ V}$$

$$I = 0.56 \text{ A}$$

	total mass	clock time	time
$P=0$	156 g	0:00.0	0 s
	155	0:45.2	45.2
	154	1:31.4	91.4
	153	2:16.2	136.2
	152	2:60.0	180.0
	151	3:47.2	227.2
$P \neq 0$	150	4:13.6	253.6
	149	4:32.1	272.1
	148	4:50.1	290.1
	147	5:08.9	308.9
	146	5:27.2	327.2
	145	5:45.7	345.7
	144	6:04.1	364.1
$P=0$	143	6:21.9	381.9
	142	7:02.3	422.3
	141	7:58.4	478.4
	140	8:51.2	531.2
	139	9:43.7	583.7
	138	10:34.6	634.6
137	11:30.7	690.7	

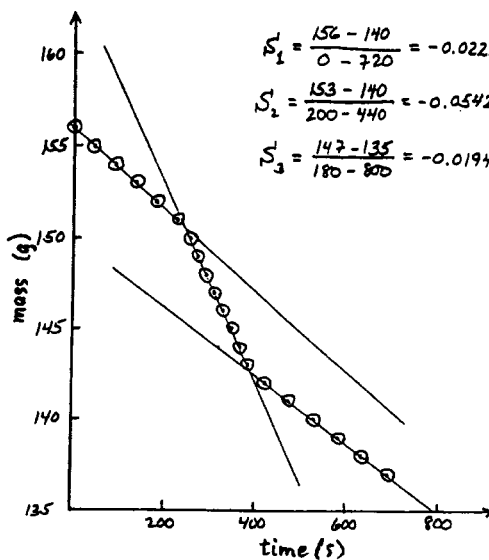

$$S_1 = \frac{156 - 140}{0 - 720} = -0.0222 \frac{\text{g}}{\text{s}}$$

$$S_2 = \frac{153 - 140}{200 - 440} = -0.0542 \frac{\text{g}}{\text{s}}$$

$$S_3 = \frac{147 - 135}{180 - 800} = -0.0194 \frac{\text{g}}{\text{s}}$$

$$S_{P \neq 0} = -0.054 \pm 0.001 \text{ g/s}$$

$$\langle S_{P=0} \rangle = -0.020 \pm 0.001 \text{ g/s}$$

$$\text{Power} = P = \left| \frac{Q}{\Delta t} \right| = L \left| \frac{\Delta M_{LN_2}}{\Delta t} \right|$$

$$P = IV = 7.11 \text{ W}$$

$$P = I^2R = 7.21 \text{ W}$$

$$P = V^2/R = 7.01 \text{ W}$$

$$P = 7.1 \pm 0.1 \text{ W}$$

$$|\Delta M_{LN_2}/\Delta t| = 0.054 - 0.020 = 0.034 \pm 0.0014 \text{ J/s}$$

$$L = \frac{P}{\Delta M_{LN_2}/\Delta t} = \frac{7.1 \pm 0.1}{0.034 \pm 0.0014} = 209 \pm 9 \text{ J/g}$$

Experimental Problem 1: Grading Scheme

Method No. 1 (5 points maximum)

- 1) 0.5 Uses $Q = mc\Delta T$ or $Q = m \int c dT$
- 2) 0.5. Uses $Q = L\Delta M_{LN_2}$
- 3) 0.5 Measures mass of aluminum correctly
- 4) 0.5 Measures ΔM_{LN_2} in some way
- 5) 0.5 Takes into account "thermal leakage" in some way and corrects for aluminum added to container
- 6) 0.5 Takes into account "thermal leakage" not being constant in time
- 7) 0.5 Uses reasonable values for c and ΔT or does $\int c dT$ integral in a reasonable way
- 8) 0.5 No mistakes made in computing L
- 9) 0.5 Error estimate is reasonable for methods used
- 10) 0.5 Value for L is within bounds set by grading team using good procedures

Method No. 2 (5 points maximum)

- 1) 0.5 Uses $P = \Delta Q/\Delta t$
- 2) 0.5 Uses $P = IV = I^2R = V^2/R$
- 3) 0.5 Uses $Q = LM_{LN_2}$
- 4) 0.5 Measures two parameters (to get P) correctly
- 5) 0.5 Measures M_{LN_2} in some way
- 6) 0.5 Takes into account "thermal leakage" in some way
- 7) 0.5 Takes into account "thermal leakage" not being constant in time
- 8) 0.5 No mistakes made in computing L
- 9) 0.5 Error estimate is reasonable for methods used
- 10) 0.5 Value for L is within bounds set by grading team using good procedures

COUNTRY: _____

XXIV INTERNATIONAL PHYSICS OLYMPIAD
WILLIAMSBURG, VIRGINIA, U.S.A.

PRACTICAL COMPETITION

Experiment No. 2

July 14, 1993

Time available: 2.5 hours

READ THIS FIRST!

INSTRUCTIONS:

1. Use only the pen provided, and only the equipment supplied.
2. Use only the marked side of the paper.
3. Write at the top of each page:
 - The number of the problem
 - The number of the page of your report
 - The total number of pages in your report.

Example (for problem 1): 1 1/4; 1 2/4; 1 3/4; 1 4/4

Experimental Problem 2

MAGNETIC MOMENTS AND FIELDS

This experiment has two parts:

- Part 1:** To determine the absolute magnitude μ_X of the magnetic moment of a small cylindrical permanent magnet, contained in the envelope marked "X". (A similar magnet, also needed for the experiment, is contained in the envelope marked "A".)
- Part 2:** To investigate the magnetic field of a given axially symmetric distribution of magnets, contained in the envelope marked "B".

In your experiments, you should make use of the following facts:

- (1) The magnetic field B produced by a dipole magnet at a point along its axis at distance x from its center is parallel to that axis and of strength given by:

$$B(x) = \frac{2\mu K}{x^3},$$

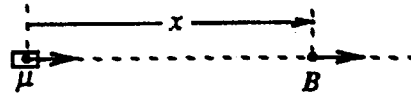

where B is in Tesla [= N/(A m)], $K = 10^{-7}$ Tesla m/A, x is in m, and μ is in A m².

- (2) The period of small torsional (angular) oscillations of a horizontal freely suspended magnet, such as a compass needle in the Earth's magnetic field, is given by:

$$T = 2\pi\sqrt{\frac{I}{\mu B_h}},$$

where B_h is the horizontal component of the net field at the magnet, and I is the moment of inertia of the magnet about a vertical axis through its center.

Apparatus

The apparatus is illustrated in the diagrams at the end. A thin thread is suspended from the upper of two shelves on a wooden stand. A magnet ("X" or "A") can be attached to the bottom end of the thread. A copper plate can be placed on the lower shelf, just below the suspended magnet, to damp out its motion if desired. Two auxiliary wooden stands are provided. One of these serves as a holder for either "A" or "X" in Part 1; the other holds the magnet system B (used in Part 2). Distances between a suspended magnet and a magnet mounted in one of the auxiliary stands can be measured with a ruler mounted on that stand.

Warning: These magnets are extremely strong. Hold onto them tightly and be careful not to let them be pulled out of your fingers.

PART 1

The magnetic moment to be determined (μ_X) is that of the pair of magnets in envelope X, labelled at the ends with a letter-number combination. Always keep this pair together. The moment of inertia of this pair has been calculated and written on envelope X. Envelope A contains another pair of magnets with north and south poles marked respectively with black and red spots. This pair is similar

to the pair from envelope X, though its magnetic moment (μ_A) cannot be assumed equal to μ_X . A given pair of magnets can be “split” and placed around the bronze disk attached to the thread, forming a “compass” whose torsional oscillation period may be measured. (The value I_X given on envelope X includes the effects of the bronze disk.)

One magnet-pair, centered in the hole in the wooden holder, can be used to influence the “compass” pair, possibly affecting its period and its angular equilibrium position. The angular position is best studied by placing the copper plate a few millimeters below the “compass” so as to provide electromagnetic damping. **Please do not mark or write on the copper plate.**

You will need to use more than one arrangement of the magnets. **Draw clearly labelled diagrams showing each experimental arrangement used. Also, write equations to show how you will combine your different observations to obtain the value of μ_X .**

Keep all magnets in the same horizontal plane. Note for the main stand that the top knob can be rotated, and the thread length adjusted. The position of each shelf can also be adjusted.

Practical Details (IMPORTANT!)

- 1) **COMPASS ASSEMBLY AND USE:** Hold one magnet from a given pair between the thumb and forefinger of one hand. Center the bronze disk over one end. Then, carefully, and without pulling on the thread, slowly bring in the second magnet. This forms the compass pair (“X” or “A”). Also, avoid pulling on the thread in taking the compass apart.
Warning: Rapid snapping of magnets or magnet pairs together can break the thread or chip the magnets. The tiny loop can be threaded again if thread breakage occurs. (Consult the organizers if necessary.)
- 2) Study the torsional mode of oscillation. To prevent excitation of the “pendulum” mode, a small assembly made of copper wire is mounted on the lower shelf of the main stand. Rotate this assembly so that the horizontal piece is up against the thread at a point about 2 mm above where the thread is tied. With a slight additional rotation in the same direction, move the wire a few mm further.
Warning: If this is not done, the two modes can “couple,” causing a periodic variation in the amplitude of the torsional oscillations, and affecting their period.
Use the nail (see diagrams at end) to start the torsional oscillations in a controlled way.
- 3) Keep magnetic or magnetizable objects stationary, and as far as possible from the experimental area. Consider such items as the nail, wrist watches, pens, etc. The table has some steel support parts; if you want to change the position of the apparatus, consider this fact.

Suggestions

- (i) The torsion constant of the thread is quite small. It turns out that you can neglect its effect in the analysis provided the thread is reasonably long, e.g. around 15 cm.

-
- (ii) You may notice that a given magnet pair does not hang horizontally. This is because of the vertical component of the Earth's field. The effect of this on the analysis is small and should be neglected. In other words, simply pretend that the magnet is horizontal.
- (iii) We suggest that you postpone the error analysis for Part 1 until after you have made the measurements needed for Part 2.
- (iv) You should not make any assumptions about the magnitude of the Earth's field.

PART 2

The aluminum tube (in envelope B) contains an axially symmetrical distribution of magnets. The magnetic field along the x axis, B_x , of this assembly varies as a function of distance x measured from the center of the tube according to the relation $B_x(x) = Cx^p$. Determine the exponent p , with its approximate error. As sketched below, you should study the field on the side in the direction of the end marked with a black spot.

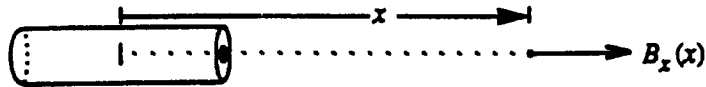

WRITE YOUR SET-UP NUMBER ON YOUR REPORT. THIS IS THE LETTER-NUMBER COMBINATION PRINTED ON THE EQUIPMENT BOX AND ALSO ON THE MAGNET ENVELOPES LIKE THIS:

#

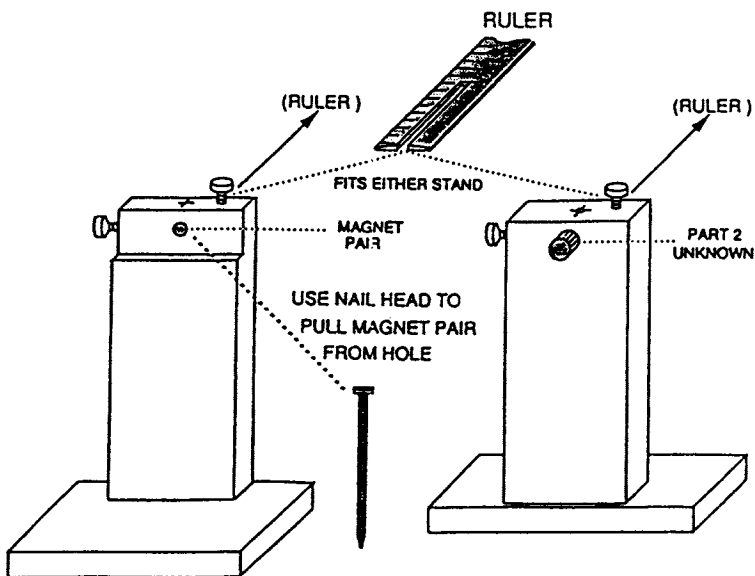
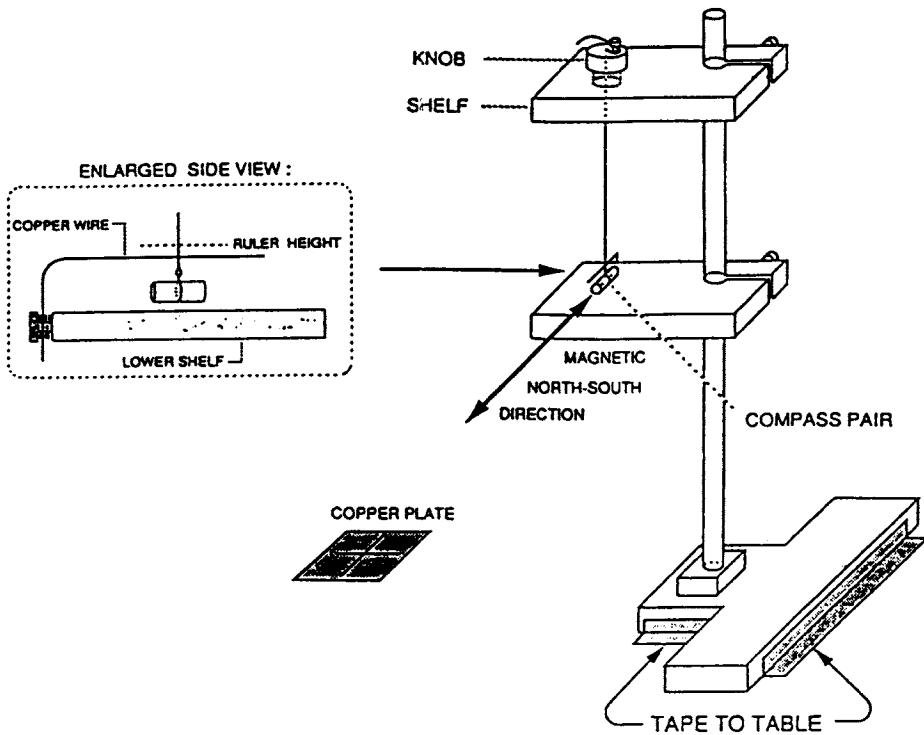

Experimental Problem 2 -- Solutions

PART 1 : DETERMINATION OF μ_X

Basic Insight :

The idea which enables one to "see into" the problem is contained in the following remark: The oscillation period of a given suspended magnet depends on the product of its moment and the (horizontal component of) the Earth's field, while the extent to which that magnet can influence the direction of another magnet used as a compass depends on the ratio of those two quantities.

It follows that by making measurements of both types, both the unknown moment and the horizontal component of the Earth's field can be determined. We suspect that this idea goes historically back to Gauss.

First Solution : The "Turn-Around Method"

Experimental Arrangement

Equation

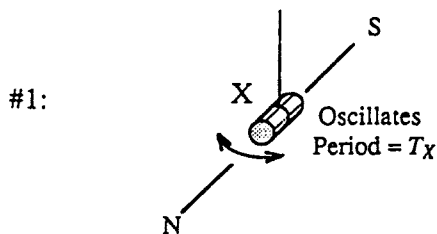

$$\mu_X B_h = I_X (2\pi/T_X)^2 \quad (1)$$

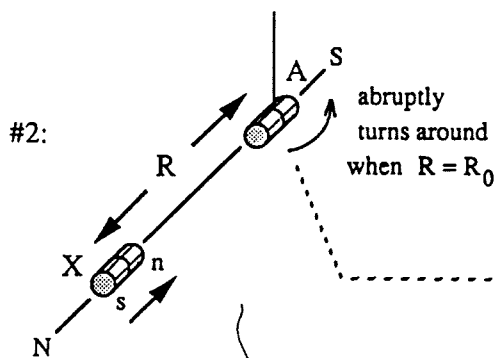

$$\mu_X \frac{2K}{R_0^3} = B_h \quad (2)$$

use copper
damping plate
beneath
compass

note that the
 μ and I values
of the compass
magnet
do not matter

Combining (1) and (2) one easily finds:

$$\mu_X = \frac{R_0^{3/2}}{(2K)^{1/2}} \frac{2\pi}{T_X} (I_X)^{1/2}$$

Second Solution : Dynamic Method with 3 Unknowns

The experience from our tests was that the "Turn-Around" method did not occur naturally to most students. They were much more comfortable with the idea of using one magnet to influence the period of another. Since the magnetic moments are not necessarily equal, it is clear that two measurements will no longer suffice. Our guess is that the following 3-measurement scheme will be the most common student choice.

Experimental Arrangement

Equation

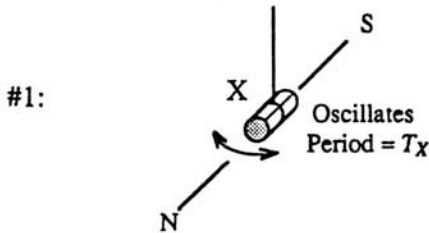

$$\mu_X B_h = I_X (2\pi/T_X)^2 \quad (1)$$

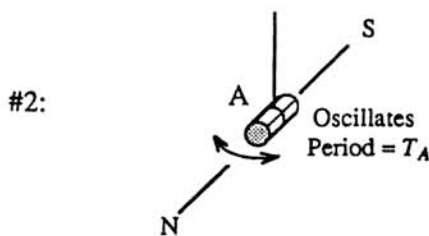

$$\mu_A B_h = I_A (2\pi/T_A)^2 \quad (2)$$

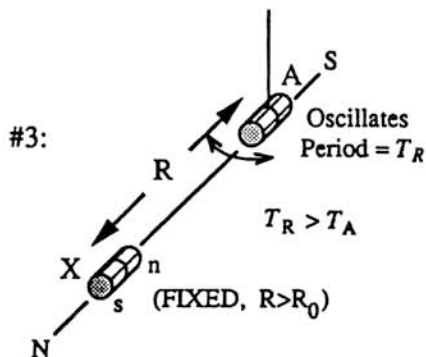

$$\mu_A \left[B_h - \mu_X \frac{2K}{R^3} \right] = I_A (2\pi/T_R)^2 \quad (3)$$

Note that the X magnet (positioned at a distance R which is somewhat larger than the turn-around distance R_0) is being used here to slow the oscillations of the A magnet on the compass.

One worries at first that there are actually 4 unknowns, since the inertial moment of A need not equal that of X. Inspection of equations (2) and (3) shows, however, that the ratio μ_X/B_h can be expressed

in terms of experimentally known quantities. Since (1) gives the product $\mu_X B_h$, the calculational strategy is clear. One easily finds:

$$\mu_X = \frac{R^{3/2}}{(2K)^{1/2}} \frac{2\pi}{T_X} (I_X)^{1/2} [1 - (T_A/T_R)^2]^{1/2} \quad (4)$$

Alternatively, by reversing its poles, one can use the X magnet to speed-up the oscillations of the A magnet. Then, of course we have $T_R < T_A$. In this case (which is formally equivalent to the first case, with a reversal of the sign of K), one finds:

$$\mu_X = \frac{R^{3/2}}{(2K)^{1/2}} \frac{2\pi}{T_X} (I_X)^{1/2} [(T_A/T_R)^2 - 1]^{1/2} \quad (4')$$

SAMPLE EXPERIMENT

The Dynamic Method just outlined was used (in the case where the X magnet was used to slow down the oscillations of the A magnet in Arrangement #3). In all cases 20 oscillations were timed. The distance R was (17.0 ± 0.1) cm. The X moment of inertia was $I_X = (4.95 \pm 0.1) \times 10^{-8} \text{ kg m}^2$. Using the notation given previously, the data were as follows:

Measurements (in seconds) of $20T_X$: 10.83, 10.99, 10.91, 10.94. [Arrangement #1]

Measurements (in seconds) of $20T_A$: 10.95, 11.10, 11.01, 10.92. [Arrangement #2]

Measurements (in seconds) of $20T_R$: 21.70, 21.65, 21.78, 21.59. [Arrangement #3]

Using a pocket calculator (HP32S) to obtain the averages and statistical errors gives:

$$T_X = (0.546 \pm 0.003) \text{ sec}$$

$$T_A = (0.550 \pm 0.004) \text{ sec}$$

$$T_R = (1.084 \pm 0.004) \text{ sec}$$

The "statistical errors" here are naively based on what the calculator gave for the estimated standard deviation around the sample mean. More carefully, one should divide this by the square root of the number of observations to give the estimated standard error of the sample mean. [Still more carefully, for such a small sample, one should apply the appropriate statistical correction factor]. For simplicity

we will use the naively calculated results. This will suffice for our purposes.

Write (4) as $\mu_X = GF$, where

$$G = \frac{R^{3/2}}{(2K)^{1/2}} \frac{2\pi}{T_X} (I_X)^{1/2} \quad \text{and} \quad F = [1 - (T_A/T_R)^2]^{1/2}$$

The expression for G is identical for that for μ_X in the "turnaround method" when $R=R_0$. This must be true, since in that case T_R goes to infinity.

Numerically

$$G = \frac{[(0.170 \pm 0.001) \text{ m}]^{3/2}}{[2 \times 10^{-7} \text{ N/A}^2]^{1/2}} \frac{2\pi}{(0.546 \pm 0.003) \text{ sec}} [(4.95 \pm 0.1) \times 10^{-8} \text{ kg m}^2]^{1/2}$$

then standard error propagation and reduction of the units give

$$G = (0.401 \pm 0.006) \text{ Am}^2$$

which is a 1.5% uncertainty. For F we find numerically :

$$F = \left\{ 1.000 - \left[\frac{(0.550 \pm 0.004) \text{ sec}}{(1.084 \pm 0.004) \text{ sec}} \right]^2 \right\}^{1/2}$$

The central value here is 0.862. One can easily use a pocket calculator to see the effects of the permitted statistical variations in each of the two places above. This shows that the effect of the numerator uncertainty is essentially ± 0.0022 , while that of the denominator is ± 0.0013 . Combining these statistically gives an net uncertainty in F of 0.0026, so that the fractional uncertainty in F is 0.0033. [An analysis of this by calculus is straightforward, but cumbersome.] Then the fractional uncertainty in μ_X is practically that in G. We find:

$$\mu_X = (0.862 \pm 0.0026) (0.401 \pm 0.006) \text{ Am} = (0.346 \pm 0.005) \text{ A m}^2.$$

By way of comparison, measurement of the same magnet X using Fluxgate Magnetometry (at a distance of around 16 cm) gave $\mu_X = (0.345 \pm 0.003) \text{ A m}^2$.

PART 2 : DISTANCE DEPENDENCE OF FIELD OF "B" UNKNOWN

Method I (Close Distances) : Nulling of Transverse Static Deflection

Arrangement (top view)

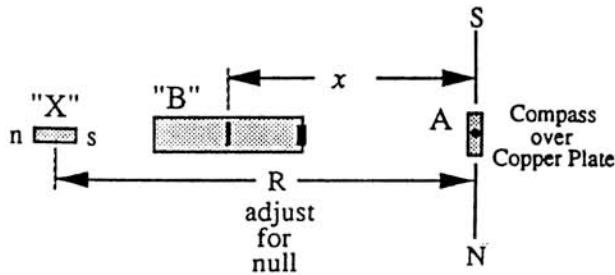

Equation

$$B_x(x) = \frac{2K\mu_X}{R^3}$$

Method II (Intermediate Distances) : Differential $1/T^2$ Technique

General Relation : $T = T_X$; B_h =local (horiz.) field $\left\{ (2\pi T)^2 = \frac{\mu_X B_h}{I_X} \right.$

Arrangement (top view)

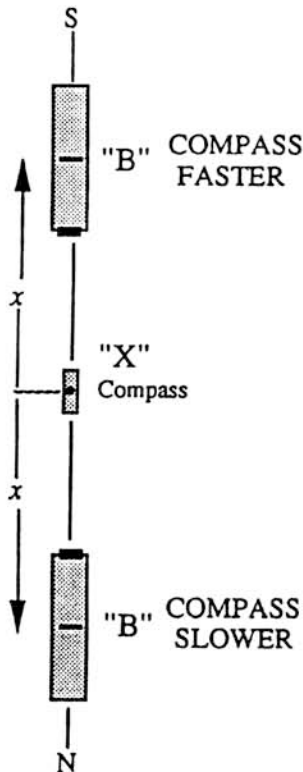

DEFINE:

$$\Delta(1/T^2) \equiv (1/T^2)_{\text{faster}} - (1/T^2)_{\text{slower}}$$

THEN:

$$\Delta(1/T^2) = \frac{\mu_X \Delta B_h}{4\pi^2 I_X} \quad \text{where } \Delta B_h = 2B_x(x)$$

$$B_x(x) = \frac{2\pi^2 I_X}{\mu_X} \Delta(1/T^2)$$

"Master Equation"

Method III (Large Distances) :

Differential $1/T^2$ Technique with Partial "Bucking" of the Earth's Field

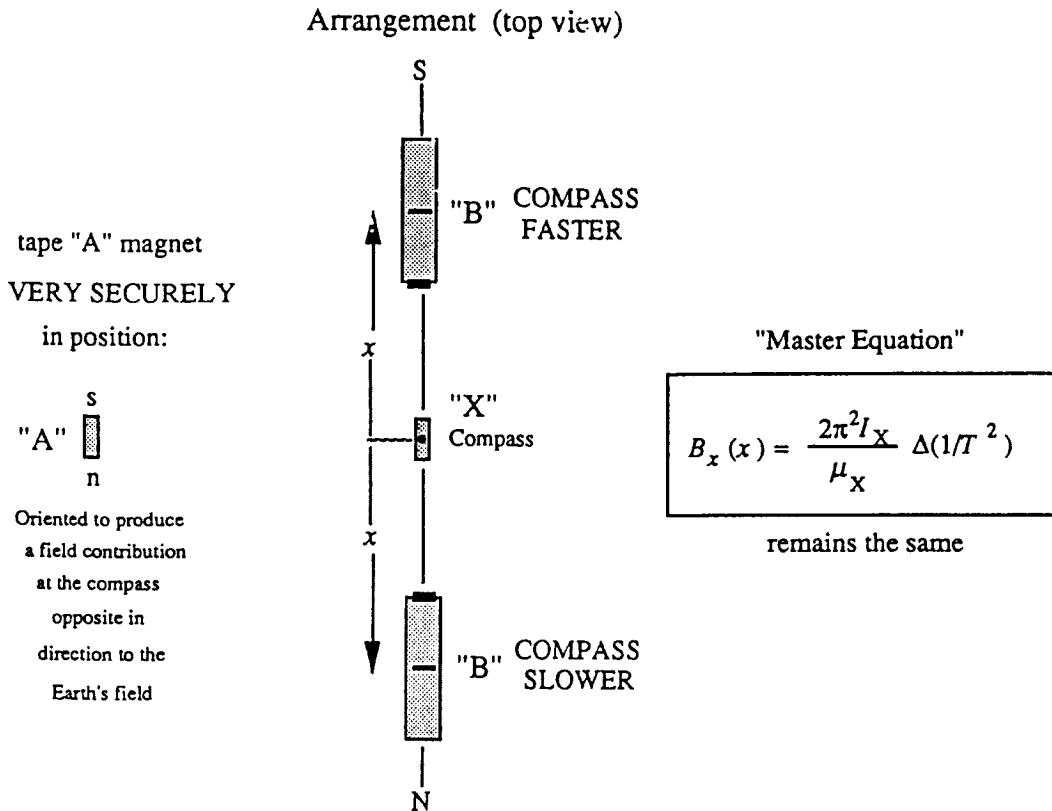

Use only partial buckout --(slow natural oscillations typically by a factor of 2)

In working at a given distance x , $\Delta(1/T^2)$ must be constant (independent of the "bucking").

$$\Delta(1/T^2) = \text{const.}$$

$$\Delta T/T^3 = \text{const.} \longrightarrow \boxed{\Delta T \propto T^3}$$

Sample Experiment

$$\text{Method I} \quad B_x(x) = \frac{2K\mu_x}{R^3} = \frac{[(2 \times 10^{-7}) \text{T m/A}][0.346 \pm 0.005] \text{Am}^2}{[R(\text{m})]^3}$$

DATA TABLE FOR METHOD I

measured data		calculated $B_x(x)$ (10^{-7} T)	standard error propagation $\Delta B/B$	see below	
x (m)	R (m)			$4\Delta x/x$	$(\Delta B/B)_{\text{eff}}$
.062±.001	.112±.0112	493.	.031	.065	.072
.0705±.0015	.133±.0015	294	.019	.085	.087
.0845±.0015	.167±.002	149	.039	.071	.081
.102±.0015	.206±.005	79	.074	.059	.095

The uncertainty in R includes the ruler reading error, together with the imprecision in locating the null position, the latter effect becoming predominant at larger x . The R uncertainty, together with the small uncertainty in μ_x define the $\Delta B/B$ values listed in the 4th column.

Of course there are also the uncertainties in the x values, which we could represent graphically by horizontal error bars. Since this is technically awkward, we choose instead to define an effective vertical uncertainty. Since it turns out that the log-log plot slope is about -4, a given fractional error in x corresponds to 4 times as much in $B(x)$. These fractional errors have been tabulated in the 5th column. From this it is clear that we should take the effective $\Delta B/B$ as the square root of the sum of the squares of the contributions in columns 4 and 5. These values, listed in column 6, form the basis for the error bars used. Though we would certainly not expect a student to do this, we would expect him to be aware of the horizontal uncertainties.

$$\text{Method II} \quad B_x(x) = \frac{2\pi^2 f X}{\mu_x} \Delta(1/T^2) = (28.2 \pm .51) \times 10^{-7} \text{ Tesla sec}^2 \cdot \Delta(1/T^2)$$

$$\bullet x = (.120 \pm .001) \text{m} :$$

Data in seconds for 20 oscillations: Pocket Calculator Results:

$$20 T_{\text{slow}} : 14.56, 14.50, 14.52, 14.58 \quad T_{\text{slow}} = (.727 \pm .0018) \text{sec}$$

$$20 T_{\text{fast}} : 11.32, 11.34, 11.31, 11.28 \quad T_{\text{fast}} = (.5656 \pm .0013) \text{sec}$$

$$\Delta(1/T^2) = [(3.1257 \pm 0.138) - (1.892 \pm 0.095)] \text{sec}^{-2} = (1.23 \pm 0.17) \text{sec}^{-2}$$

$$\longrightarrow B_x(x) = (34.7 \pm 0.8) \times 10^{-7} \text{ Tesla}$$

Method III

Introduced bucking magnet in transverse position to slow oscillations in Earth's Field to about 1.2sec

Master equation is still:

$$B_x(x) = \frac{2\pi^2 I_X}{\mu_X} \Delta(1/T^2) = (28.2 \pm .51) \times 10^{-7} \text{ Tesla sec}^2 \cdot \Delta(1/T^2)$$

● $x = (.150 \pm .001)\text{m} :$

Data in seconds for 20 oscillations:

Pocket Calculator Results:

20 $T_{\text{slow}} :$ 27.90, 27.80, 27.78, 27.77

$T_{\text{slow}} = (1.391 \pm .003)\text{sec}$

20 $T_{\text{fast}} :$ 19.56, 19.66, 19.50, 19.64

$T_{\text{fast}} = (.9795 \pm .0037)\text{sec}$

$$\Delta(1/T^2) = [(1.0422 \pm .0079) - (.5171 \pm .0022)] \text{sec}^{-2} = (.525 \pm .0082) \text{sec}^{-2}$$

$$\longrightarrow B_x(x) = (14.8 \pm .35) \times 10^{-7} \text{ Tesla}$$

● $x = (.170 \pm .001)\text{m} :$

Data in seconds for 20 oscillations:

Pocket Calculator Results:

20 $T_{\text{slow}} :$ 24.97, 24.97, 24.87

$T_{\text{slow}} = (1.2468 \pm .0029)\text{sec}$

20 $T_{\text{fast}} :$ 20.55, 20.46, 20.79, 20.65

$T_{\text{fast}} = (1.0306 \pm .00708)\text{sec}$

$$\Delta(1/T^2) = [(.9415 \pm .013) - (.6433 \pm .0030)] \text{sec}^{-2} = (.298 \pm .013) \text{sec}^{-2}$$

$$\longrightarrow B_x(x) = (8.4 \pm 0.4) \times 10^{-7} \text{ Tesla}$$

● $x = (.190 \pm .001)\text{m} :$

Data in seconds for 20 oscillations:

Pocket Calculator Results:

20 $T_{\text{slow}} :$ 17.17, 17.15, 17.11, 17.10

$T_{\text{slow}} = (.8566 \pm .0017)\text{sec}$

20 $T_{\text{fast}} :$ 16.01, 15.93, 15.91, 15.92

$T_{\text{fast}} = (.797 \pm .0029)\text{sec}$

$$\Delta(1/T^2) = [(1.574 \pm .028) - (1.3628 \pm .0053)] \text{sec}^{-2} = (.2112 \pm .029) \text{sec}^{-2}$$

$$\longrightarrow B_x(x) = (6.0 \pm 0.8) \times 10^{-7} \text{ Tesla}$$

● $x = (.220 \pm .001)\text{m} :$

Data in seconds for 20 oscillations:

Pocket Calculator Results:

20 $T_{\text{slow}} :$ 23.80, 23.76, 23.70

$T_{\text{slow}} = (1.1877 \pm .00252)\text{sec}$

20 $T_{\text{fast}} :$ 22.27, 21.98, 21.86, 21.94

$T_{\text{fast}} = (1.1006 \pm .0089)\text{sec}$

$$\Delta(1/T^2) = [(.8255 \pm .0134) - (.7089 \pm .0030)] \text{sec}^{-2} = (.1166 \pm .014) \text{sec}^{-2}$$

$$\longrightarrow B_x(x) = (3.3 \pm 0.4) \times 10^{-7} \text{ Tesla}$$

DATA TABLE FOR METHODS II and III

x (m)	Method	calculated $B_x(x)$ (10^{-7} T)	standard error propagation $\Delta B/B$	see above	
				$4\Delta x/x$	$(\Delta B/B)_{\text{eff}}$
.120±.001	II	34.7	.023	.033	.040
.150±.001	III	14.8	.024	.027	.036
.170±.001	III	8.4	.05	.024	.055
.190±.001	III	6.0	.13	.021	.13
.220±.001	III	3.3	.12	.018	.12

The equivalent vertical uncertainties have calculated as before and tabulated in the last column above. These give the error bars on the log-log plot shown on the next page. The three different methods are nicely consistent, and the whole data set well fits the power law indicated by the drawn line. When this is done on the regular log paper (as provided), the easiest way in this case to get the slope is to use a pocket calculator to find the ratio of the log of the vertical rise ratio to that of the horizontal run ratio for the possible lines consistent with the errors. Since the line has to drop vertically through three decades in total, this is roughly

$$\text{slope} = \frac{-3}{\log_{10} \left[\frac{(0.30 \pm 0.02)}{(0.051 \pm 0.03)} \right]} = -3.9 \pm 0.15$$

For this particular unknown, the fluxgate magnetometer data gave an effective exponent of -3.92 over the range from 0.07m to 0.22m. A more detailed absolute comparison with those measurements is shown on the second graph. Here the drawn line corresponds to the actual magnetometer data. The student experiment is clearly doing an excellent job. Of particular interest is the next to the lowest point ($x=0.19$ m). For this point, the "buckout" magnet had been moved out a little bit so that the natural compass period in the Earth's field was about 0.89 sec., which was close to the period of the "pendulum mode". This was done deliberately to test the effectiveness of the copper wire "mode-decoupler". The point at $x=0.19$ m which is on the line was taken using the decoupler. The point at the same x value which is almost a factor of 3 higher than the line was taken without the decoupler.

This shows that the decoupler is both effective and important. Without it, the "fast" and "slow" measurements are effected differently by the coupling to the pendulum mode. Then the small difference between them can be very poorly determined.

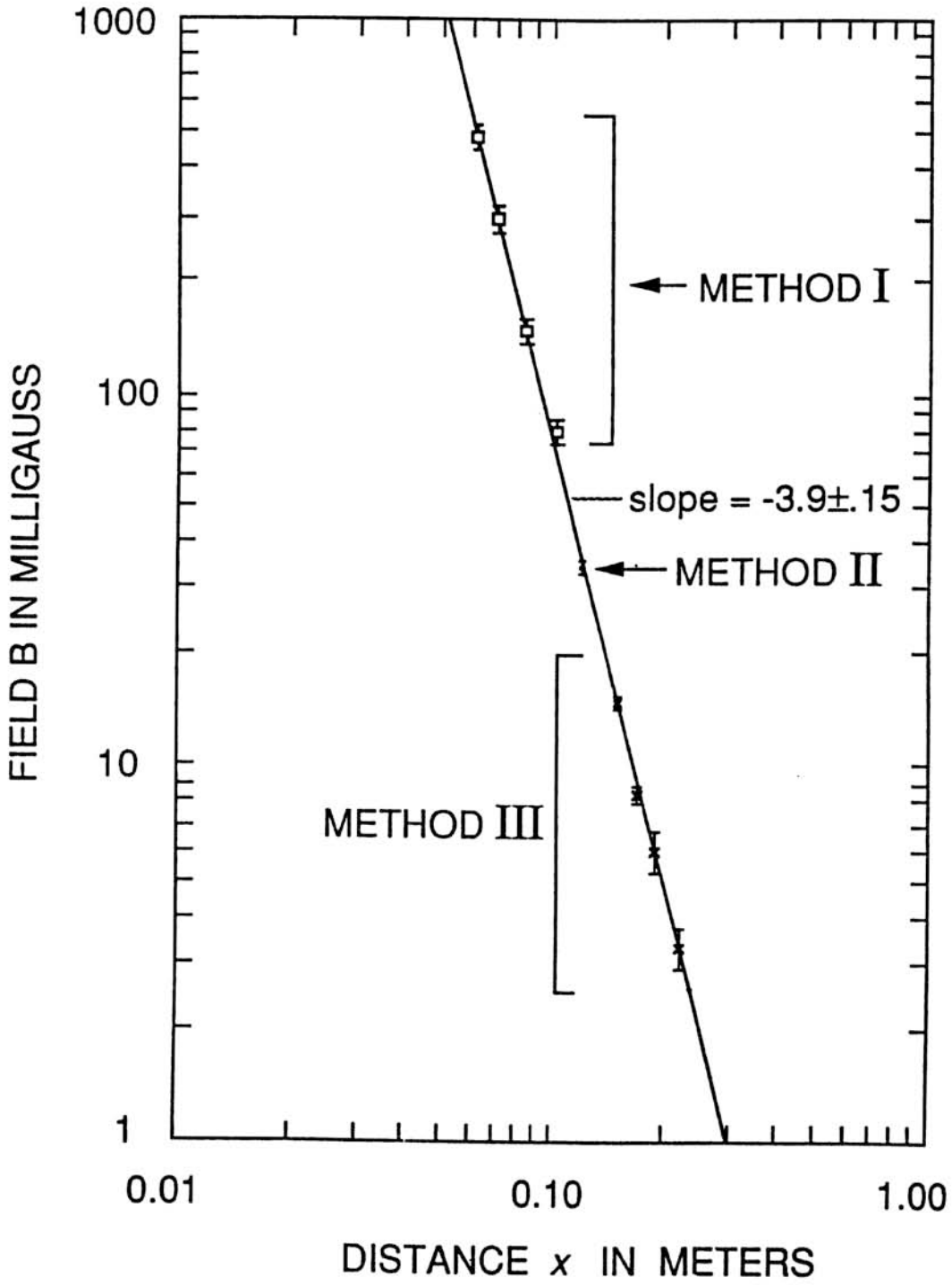

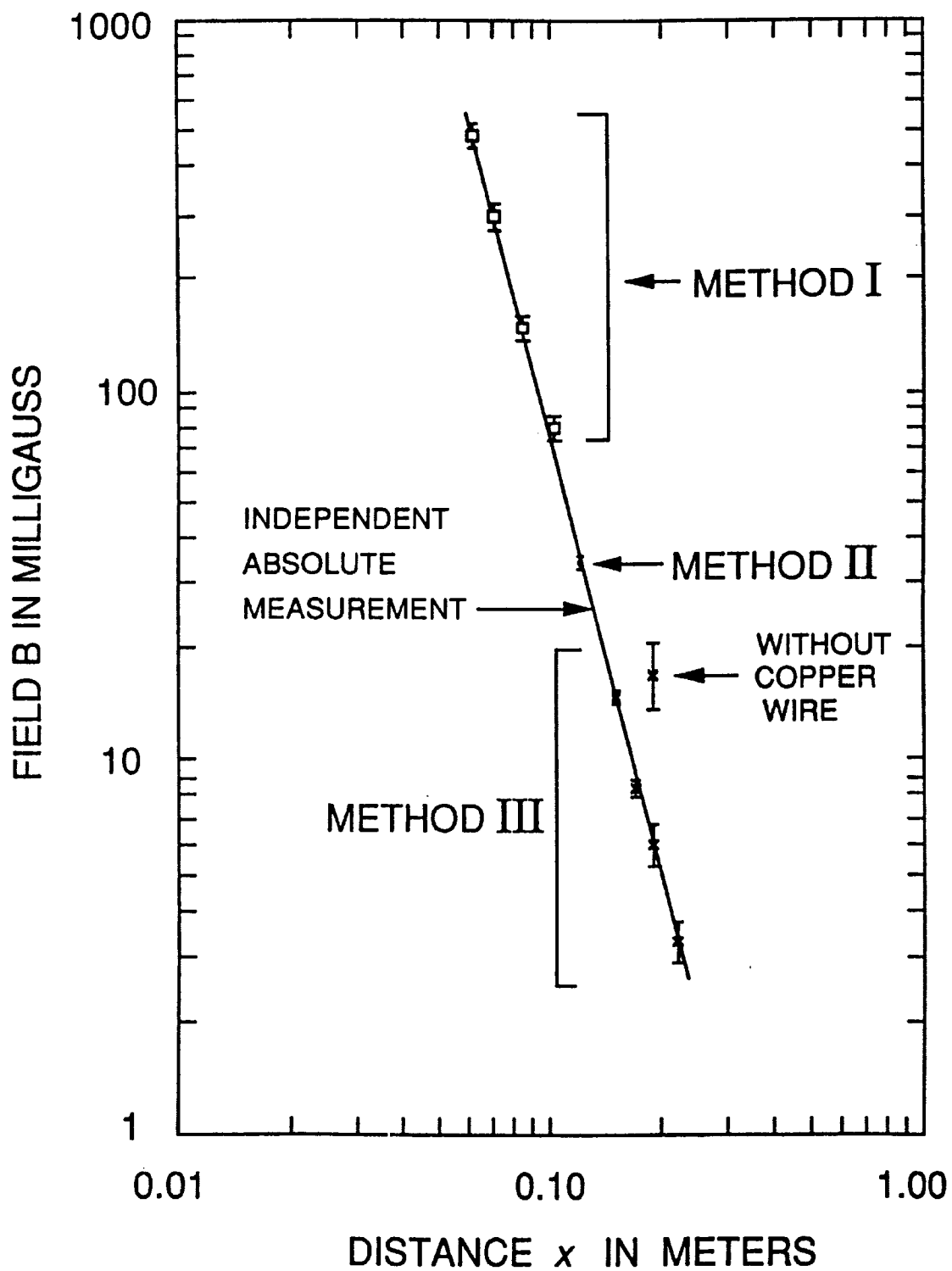

Experimental Problem 2: Grading Scheme

Part 1

- | | |
|------------------------------|---|
| 2.5 points | Show how μ_X is calculated, clearly labeled diagram |
| 1.5 points | μ_X is correctly stated |
| 0 - 1 points (sliding scale) | error analysis |
| 0 - 1 points (sliding scale) | consistency with "correct" range |

Part 2

- | | |
|------------------------------|--|
| 1.0 points | A diagram of a technique that can be used |
| 1.0 points | Correct measurements at 3 distances at least |
| 0 - 1 points (sliding scale) | Accuracy of the result (correct value of p) |
| 0 - 1 points (sliding scale) | Precision and error analysis |

THE EXAMINATION
XXV INTERNATIONAL PHYSICS OLYMPIAD
BEIJING, PEOPLE'S REPUBLIC CHINA
THEORETICAL COMPETITION

July 13, 1994

Time available: 5 hours

READ THIS FIRST!

INSTRUCTIONS:

1. Use only the ball pen provided.
2. Your graphs should be drawn on the answer sheets attached to the problem.
3. Your solutions should be written on the sheets of paper attached to the problems.
4. Write at the top of the first page of each problem:
 - The total number of pages in your solution to the problem
 - Your name and code number

Theoretical Problem 1

RELATIVISTIC PARTICLE

In the theory of special relativity the relation between energy E and momentum P or a free particle with rest mass m_0 is

$$E = \sqrt{p^2 c^2 + m_0^2 c^4} = mc^2$$

When such a particle is subject to a conservative force, the total energy of the particle, which is the sum of $\sqrt{p^2 c^2 + m_0^2 c^4}$ and the potential energy, is conserved. If the energy of the particle is very high, the rest energy of the particle can be ignored (such a particle is called an ultra relativistic particle).

- 1) consider the one dimensional motion of a very high energy particle (in which rest energy can be neglected) subject to an attractive central force of constant magnitude f . Suppose the particle is located at the centre of force with initial momentum p_0 at time $t=0$. Describe the motion of the particle by separately plotting, for at least one period of the motion: x against time t , and momentum p against space coordinate x . Specify the coordinates of the “turning points” in terms of given parameters p_0 and f . Indicate, with arrows, the direction of the progress of the motion in the (p, x) diagram. There may be short intervals of time during which the particle is not ultrarelativistic. However, these should be neglected.

Use Answer Sheet 1.

- 2) A meson is a particle made up of two quarks. The rest mass M of the meson is equal to the total energy of the two-quark system divided by c^2 .

Consider a one-dimensional model for a meson at rest, in which the two quarks are assumed to move along the x -axis and attract each other with a force of constant magnitude f . It is assumed they can pass through each other freely. For analysis of the high energy motion of the quarks the rest mass of the quarks can be neglected. At time $t=0$ the two quarks are both at $x=0$. Show separately the motion of the two quarks graphically by a (x, t) diagram and a (p, x) diagram, specify the coordinates of the “turning points” in terms of M and f , indicate the direction of the process in your (p, x) diagram, and determine the maximum distance between the two quarks.

Use Answer Sheet 2.

- 3) The reference frame used in part 2 will be referred to as frame S , the Lab frame, referred to as S' , moves in the negative x -direction with a constant velocity $v=0.6c$. the coordinates in the two reference frames are so chosen that the point

$x=0$ in S coincides with the point $x'=0$ in S'' at time $t=t'=0$. Plot the motion of the two quarks graphically in a (x', t') diagram. Specify the coordinates of the turning points in terms of M, f and c , and determine the maximum distance between the two quarks observed in Lab frame S' .

Use Answer Sheet 3.

The coordinates of particle observed in reference frames S and S'' are related by the Lorentz transformation

$$\begin{cases} x' = \gamma(x + \beta ct) \\ t' = \gamma(t + \beta \frac{x}{c}) \end{cases}$$

where $\beta = v/c, \gamma = 1/\sqrt{1-\beta^2}$ and v is the velocity of frame S moving relative to the frame S'' .

- 4) For a meson with rest energy $Mc^2=140$ MeV and velocity $0.60c$ relative to the Lab frame S'' , determine its energy E' in the Lab Frame S'' .

ANSWER SHEET 1

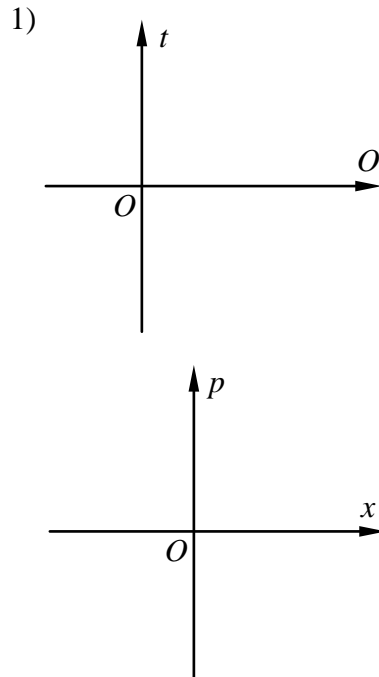

ANSWER SHEET 2

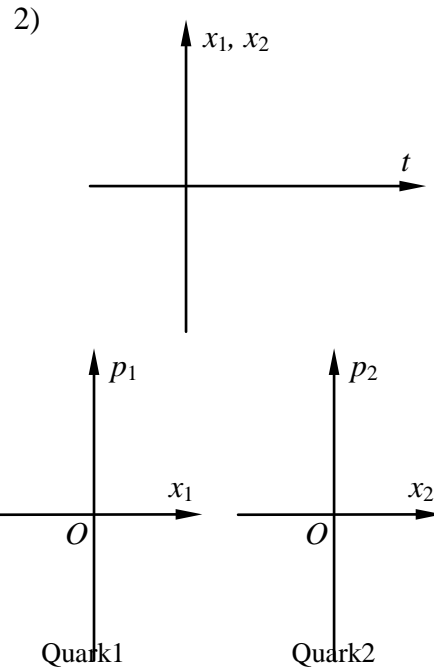

The maximum distance between the two quarks is $d=$

ANSWER SHEET 3

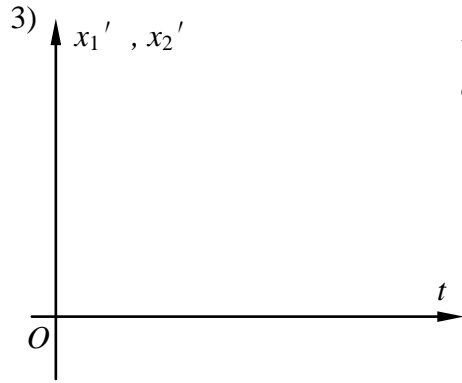

The maximum distance between the two quarks observed in S' frame is $d' =$

Theoretical Problem 1—Solution

1) 1a. Taking the force center as the origin of the space coordinate x and the zero potential point, the potential energy of the particle is

$$U(x) = f |x| \tag{1}$$

The total energy is

$$W = \sqrt{p^2 c^2 + m_0^2 c^4} + f |x|.$$

1b. Neglecting the rest energy, we get

$$W = |p| c + f |x|, \tag{2}$$

Since W is conserved throughout the motion, so we have

$$W = |p| c + f |x| = p_0 c, \tag{3}$$

Let the x axis be in the direction of the initial momentum of the particle,

$$\left. \begin{aligned} pc + fx &= p_0 c && \text{when } x > 0, \quad p > 0; \\ -pc + fx &= p_0 c && \text{when } x > 0, \quad p < 0; \\ pc - fx &= p_0 c && \text{when } x < 0, \quad p > 0; \\ -pc - fx &= p_0 c && \text{when } x < 0, \quad p < 0. \end{aligned} \right\} \tag{4}$$

The maximum distance of the particle from the origin, let it be L , corresponds to $p=0$. It is

$$L = p_0 c / f.$$

1c. From Eq. 3 and Newton's law

$$\frac{dp}{dt} = F = \begin{cases} -f, & x > 0; \\ f, & x < 0; \end{cases} \tag{5}$$

we can get the speed of the particle as

$$\left| \frac{dx}{dt} \right| = \frac{c}{f} \left| \frac{dp}{dt} \right| = c, \tag{6}$$

i.e. the particle with very high energy always moves with the speed of light except that it is in the region extremely close to the points $x = \pm L$. The time for the particle to move from origin to the point $x = L$, let it be denoted by τ , is

$$\tau = L/c = p_0/f.$$

So the particle moves to and for between $x = L$ and $x = -L$ with speed c and period $4\tau = 4p_0/f$. The relation between x and t is

$$\left. \begin{aligned} x &= ct, & 0 \leq t \leq \tau \\ x &= 2L - ct, & \tau \leq t \leq 2\tau, \\ x &= -2L + ct, & 2\tau \leq t \leq 3\tau, \\ x &= ct - 4L, & 3\tau \leq t \leq 4\tau, \end{aligned} \right\} \quad (7)$$

The required answer is thus as given in Fig. 1 and Fig. 2.

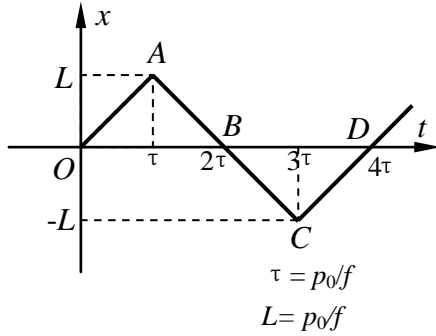

Fig. 1

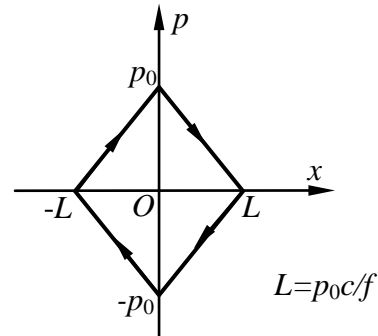

Fig. 2

2) The total energy of the two-quark system can be expressed as

$$Mc^2 = |p_1|c + |p_2|c + f|x_1 - x_2|, \quad (8)$$

where x_1, x_2 are the position coordinates and p_1, p_2 are the momenta of quark 1 and quark 2 respectively. For the rest meson, the total momentum of the two quarks is zero and the two quarks move symmetrically in opposite directions, we have

$$p = p_1 + p_2 = 0, \quad p_1 = -p_2, \quad x_1 = -x_2. \quad (9)$$

Let p_0 denote the momentum of the quark 1 when it is at $x=0$, then we have

$$Mc^2 = 2p_0c \quad \text{or} \quad p_0 = Mc/2 \quad (10)$$

From Eq. 8, 9 and 10, the half of the total energy can be expressed in terms of p_1 and x_1 of quark 1:

$$p_0c = |p_1|c + f|x_1|, \quad (11)$$

just as though it is a one particle problem as in part 1 (Eq. 3) with initial momentum

$p_0 = Mc/2$. From the answer in part 1 we get the (x, t) diagram and (p, x) diagram of the motion of quark 1 as shown in Figs. 3 and 4. For quark 2 the situation is similar except that the signs are reversed for both x and p ; its (x, t) and (p, x) diagrams are shown in Figs. 3 and 4.

The maximum distance between the two quarks as seen from Fig. 3 is

$$d = 2L = 2p_0c/f = Mc^2/f. \quad (12)$$

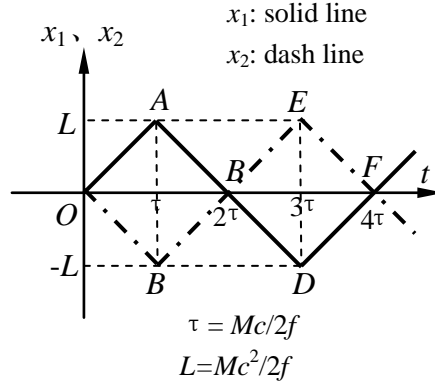

Fig. 3

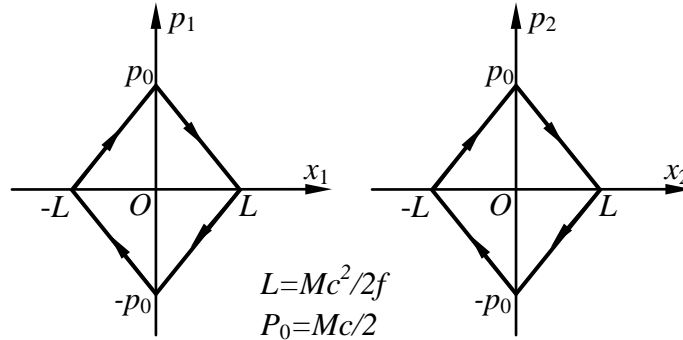

Fig. 4a

Quark1

Fig. 4b

Quark2

3) The reference frame S moves with a constant velocity $V=0.6c$ relative to the Lab frame S'' in the x' axis direction, and the origins of the two frames are coincident at the beginning ($t = t' = 0$). The Lorentz transformation between these two frames is given by:

$$\begin{aligned} x' &= \gamma(x + \beta ct), \\ t' &= \gamma(t + \beta x/c), \end{aligned} \quad (13)$$

where $\beta = V/c$, and $\gamma = 1/\sqrt{1-\beta^2}$. With $V = 0.6c$, we have $\beta = 3/5$, and $\gamma = 5/4$. Since the Lorentz transformation is linear, a straight line in the (x, t) diagram

transforms into a straight line the (x', t') diagram, thus we need only to calculate the coordinates of the turning points in the frame S' .

For quark 1, the coordinates of the turning points in the frames S and S' are as follows:

Frame S		Frame S'	
x_1	t_1	$x'_1 = \gamma(x_1 + \beta ct_1)$ $= \frac{5}{4}x_1 + \frac{3}{4}ct_1$	$t'_1 = \gamma(t_1 + \beta x_1/c)$ $= \frac{5}{4}t_1 + \frac{3}{4}x_1/c$
0	0	0	0
L	τ	$\gamma(1 + \beta)L = 2L$	$\gamma(1 + \beta)\tau = 2\tau$
0	2τ	$2\gamma\beta L = \frac{3}{2}L$	$2\gamma\tau = \frac{5}{2}\tau$
$-L$	3τ	$\gamma(3\beta - 1)L = L$	$\gamma(3 - \beta)\tau = 3\tau$
0	4τ	$4\gamma\beta L = 3L$	$4\gamma\tau = 5\tau$

where $L = p_0 c / f = Mc^2 / 2f$, $\tau = p_0 / f = Mc / 2f$.

For quark 2, we have

Frame S		Frame S'	
x_2	t_2	$x'_2 = \gamma(x_2 + \beta ct_2)$ $= \frac{5}{4}x_2 + \frac{3}{4}ct_2$	$t'_2 = \gamma(t_2 + \beta x_2/c)$ $= \frac{5}{4}t_2 + \frac{3}{4}x_2/c$
0	0	0	0
$-L$	τ	$-\gamma(1 - \beta)L = -\frac{1}{2}L$	$\gamma(1 - \beta)\tau = \frac{1}{2}\tau$
0	2τ	$2\gamma\beta L = \frac{3}{2}L$	$2\gamma\tau = \frac{5}{2}\tau$
L	3τ	$\gamma(3\beta + 1)L = \frac{7}{2}L$	$\gamma(3 + \beta)\tau = \frac{9}{2}\tau$
0	4τ	$4\gamma\beta L = 3L$	$4\gamma\tau = 5\tau$

With the above results, the (x', t') diagrams of the two quarks are shown in Fig. 5.

The equations of the straight lines OA and OB are:

$$x'_1(t') = ct'; \quad 0 \leq t' \leq \gamma(1 + \beta)\tau = 2\tau; \quad (14a)$$

$$x'_2(t') = -ct'; \quad 0 \leq t' \leq \gamma(1 - \beta)\tau = \frac{1}{2}\tau \quad (14b)$$

The distance between the two quarks attains its maximum d' when $t' = \frac{1}{2}\tau$, thus we have maximum distance

$$d' = 2c\gamma(1 - \beta)\tau = 2\gamma(1 - \beta)L = \frac{Mc^2}{2f}. \quad (15)$$

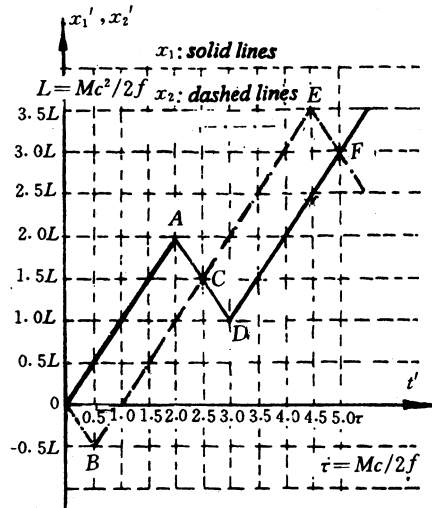

Fig. 5

4) It is given the meson moves with velocity $V=0.6$ relative to the Lab frame, its energy measured in the Lab frame is

$$E' = \frac{Mc^2}{\sqrt{1 - \beta^2}} = \frac{1}{0.8} \times 140 = 175 \text{ MeV}.$$

Grading Scheme

Part 1 2 points, distributed as follows:

- 0.4 point for the shape of $x(t)$ in Fig. 1;
- 0.3 point for 4 equal intervals in Fig. 1;
- (0.3 for correct derivation of the formula only)
- 0.1 each for the coordinates of the turning points A and C, 0.4 point in total;
- 0.4 point for the shape of $p(x)$ in fig. 2; (0.2 for correct derivation only)
- 0.1 each for specification of p_0 , $L = p_0c/f$, $-p_0$, $-L$ and arrows, 0.5 point in total.
- (0.05 each for correct calculations of coordinate of turning points only).

Part 2 4 points, distributed as follows:

- 0.6 each for the shape of $x_1(t)$ and $x_2(t)$, 1.2 points in total;
- 0.1 each for the coordinates of the turning points A, B, D and E in Fig. 3, 0.8 point in total;

0.3 each for the shape of $p_1(x_1)$ and $p_2(x_2)$, 0.6 point in total;

0.1 each for $p_0 = Mc/2$, $L = Mc^2/2f$, $-p_0$, $-L$ and arrows in Fig. 4a and Fig. 4b, 1 point in total;

0.4 point for $d = Mc^2/f$

Part 3 3 point, distributed as follows:

0.8 each for the shape of $x'_1(t')$ and $x'_2(t')$, 1.6 points in total;

0.1 each for the coordinates of the turning points A, B, D and E in Fig. 5, 0.8 point in total; (0.05 each for correct calculations of coordinate of turning points only).

0.6 point for $d' = Mc^2/2f$.

Part 4 1 point (0.5 point for the calculation formula; 0.5 point for the numerical value and units)

Theoretical Problem 2

SUPERCONDUCTING MAGNET

Superconducting magnets are widely used in laboratories. The most common form of superconducting magnets is a solenoid made of superconducting wire. The wonderful thing about a superconducting magnet is that it produces high magnetic fields without any energy dissipation due to Joule heating, since the electrical resistance of the superconducting wire becomes zero when the magnet is immersed in liquid helium at a temperature of 4.2 K. Usually, the magnet is provided with a specially designed superconducting switch, as shown in Fig. 1. The resistance r of the switch can be controlled: either $r=0$ in the superconducting state, or $r=r_n$ in the normal state. When the persistent mode, with a current circulating through the magnet and superconducting switch indefinitely. The persistent mode allows a steady magnetic field to be maintained for long periods with the external source cut off.

The details of the superconducting switch are not given in Fig. 1. It is usually a small length of superconducting wire wrapped with a heater wire and suitably thermally insulated from the liquid helium bath. On being heated, the temperature of the superconducting wire increases and it reverts to the resistive normal state. The typical value of r_n is a few ohms. Here we assume it to be 5Ω . The inductance of a superconducting magnet depends on its size; assume it be 10 H for the magnet in Fig. 1. The total current I can be changed by adjusting the resistance R .

This problem will be graded by the plots only!

The arrows denote the positive direction of I , I_1 and I_2 .

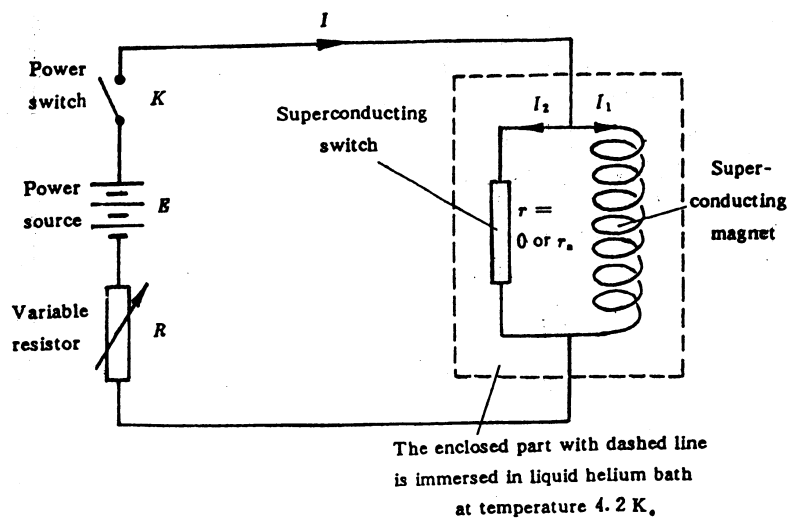

Fig. 1

1) If the total current I and the resistance r of the superconducting switch are controlled

to vary with time in the way shown in Figs, 2a and 2b respectively, and assuming the currents I_1 and I_2 flowing through the magnet and the switch respectively are equal at the beginning (Fig. 2c and Fig. 2d), how do they vary with time from t_1 to t_4 ? Plot your answer in Fig. 2c and Fig. 2d

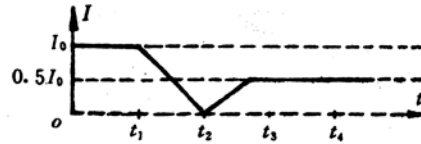
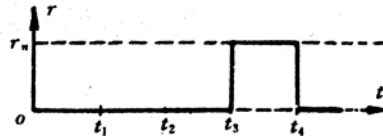
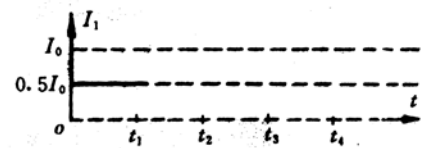

Fig.2a



2b



2c

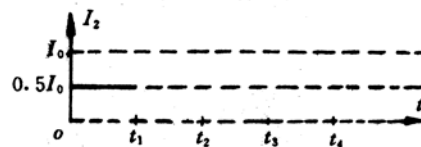

2d

2) Suppose the power switch K is turned on at time $t=0$ when $r=0$, $I_1=0$ and $R=7.5 \Omega$, and the total current I is $0.5A$. With K kept closed, the resistance r of the superconducting switch is varied in the way shown in Fig. 3b. Plot the corresponding time dependences of I , I_1 and I_2 in Figs. 3a, 3c and 3d respectively.

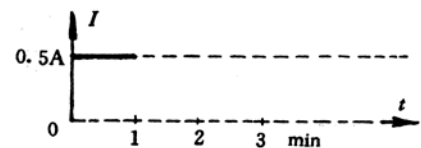
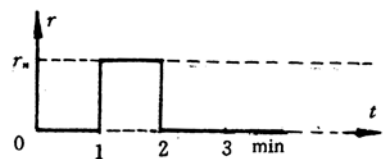
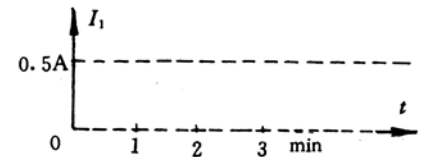

Fig. 3a



3b



3c

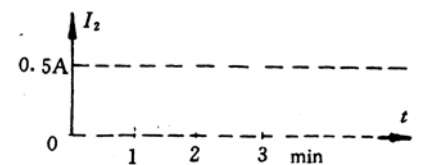

3d

3) Only small currents, less than $0.5A$, are allowed to flow through the

superconducting switch when it is in the normal state, with larger currents the switch will be burnt out. Suppose the superconducting magnet is operated in a persistent mode, i. e. $I=0$, and $I_1=i_1$ (e. g. 20A), $I_2=-i_1$, as shown in Fig. 4, from $t=0$ to $t=3\text{min}$. If the experiment is to be stopped by reducing the current through the magnet to zero, how would you do it? This has to be done in several operation steps. Plot the corresponding changes of I , r , I_1 and I_2 in Fig. 4

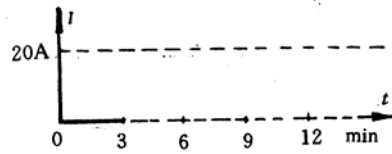
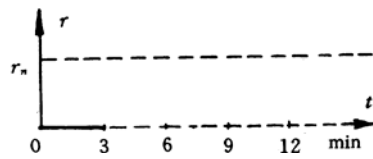
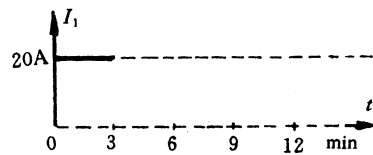

Fig. 4a



4b



4c

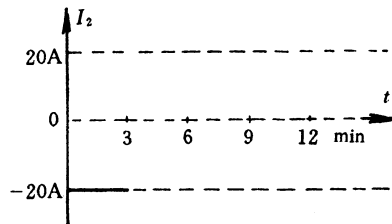

4d

4) Suppose the magnet is operated in a persistent mode with a persistent current of 20A ($t=0$ to $t=3\text{min}$. See Fig. 5). How would you change it to a persistent mode with a current of 30a? plot your answer in Fig. 5.

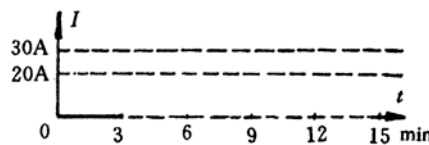
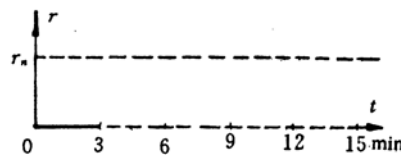
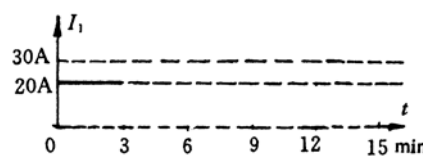

Fig. 5a



5b



5c

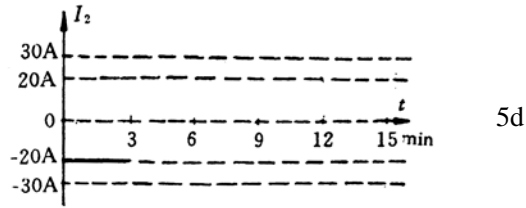

Theoretical Problem 2—Solution

1) For $t=t_1$ to t_3

Since $r = 0$, the voltage across the magnet $V_M = LdI_1 / dt = 0$, therefore,

$$I_1 = I_1(t_1) = \frac{1}{2} I_0;$$

$$I_2 = I - I_1 = I - \frac{1}{2} I_0.$$

For $t=t_3$ to t_4

Since $I_2=0$ at $t=t_3$, and I is kept at $\frac{1}{2} I_0$ after

$t = t_3$, $V_M = I_2 r_n = 0$, therefore, I_1 and I_2 will not change.

$$I_1 = \frac{1}{2} I_0;$$

$$I_2 = 0$$

These results are shown in Fig. 6.

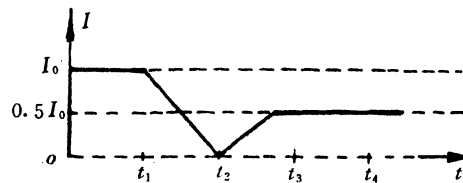
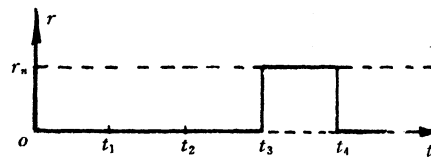
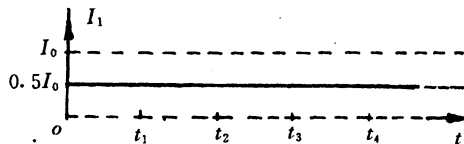

Fig. 6a



6b



6c

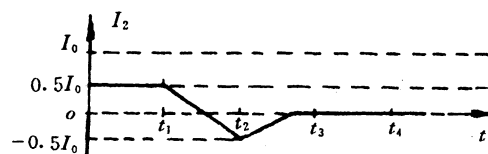

6d

2) For $t = 0$ to $t = 1$ min:

Since $r = 0$, $V_M = LdI_1/dt = 0$

$$I_1 = I_1(0) = 0$$

$$I_2 = I - I_1 = 0.5 \text{ A.}$$

At $t = 1$ min, r suddenly jumps from 0 to r_n , I will drop from E/R to $E/(R + r_n)$ instantaneously, because I_1 can not change abruptly due to the inductance of the magnet coil. For $E/R = 0.5 \text{ A}$, $R = 7.5 \Omega$ and $R_n = 5 \Omega$. I will drop to 0.3 A .

For $t = 1$ min to 2 min:

I , I_1 and I_2 gradually approach their steady values:

$$I = \frac{E}{R} = 0.5 \text{ A,}$$

$$I_1 = I = 0.5 \text{ A}$$

$$I_2 = 0.$$

The time constant

$$\tau = \frac{L(R + r_n)}{Rr_n}.$$

When $L = 10 \text{ H}$, $R = 7.5 \Omega$ and $r_n = 5 \Omega$, $\tau = 3$ sec.

For $t = 2$ min to 3 min:

Since $r = 0$, I_1 and I_2 will not change, that is

$$I_1 = 0.5 \text{ A and } I_2 = 0$$

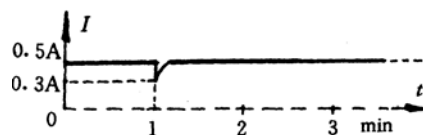
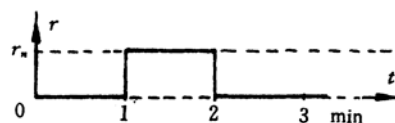
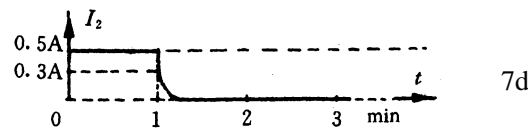
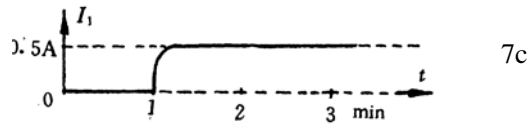

Fig. 7a



7b



3) The operation steps are:

First step

Turn on power switch K , and increase the total current I to 20 A, i. e. equal to I_1 .

Since the superconducting switch is in the state $r = 0$, so that $V_M = L \, dI_1 / dt = 0$, that is, I_1 can not change and I_2 increases by 20A, in other words, I_2 changes from -20 A to zero.

Second step

Switch r from 0 to r_n .

Third step

Gradually reduce I to zero while keeping $I_2 < 0.5$ A: since $I_2 = V_M / r_n$ and $V_m = L \, dI_1 / dt$, when $L = 10$ H, $r_n = 5 \Omega$, the requirement $I_2 < 0.5$ A corresponds to $dI_1 / dt < 0.25$ A/sec, that is, a drop of < 15 A in 1 min. In Fig. 8 $dI / dt \sim 0.1$ A/sec and dI_1 / dt is around this value too, so the requirement has been fulfilled.

Final step

Switch r to zero when $V_M = 0$ and turn off the power switch K . These results are shown in Fig. 8.

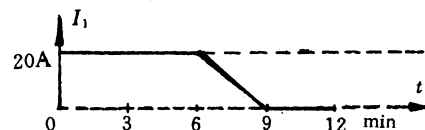
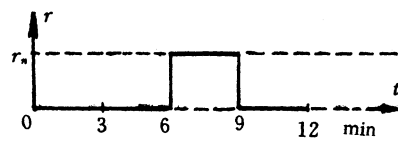
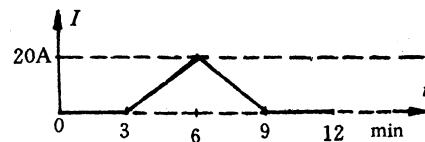

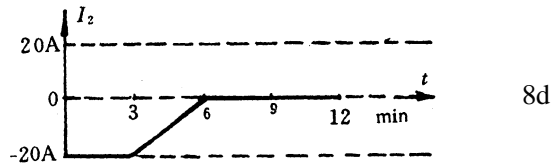

4) **First step** and **second step** are the same as that in part 3, resulting in $I_2 = 0$.

Third step Increase I by 10 A to 30 A with a rate subject to the requirement $I_2 < 0.5$ A.

Fourth step Switch r to zero when $V_M = 0$.

Fifth step Reduce I to zero, $I_1 = 30$ A will not change because V_M is zero. $I_2 = I - I_1$ will change to -30 A. The current flowing through the magnet is thus closed by the superconducting switch.

Final step Turn off the power switch K . The magnet is operating in the persistent mode.

These results are shown in Fig. 9.

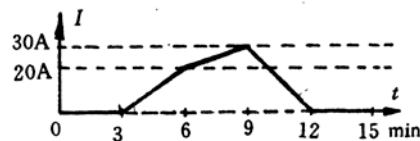
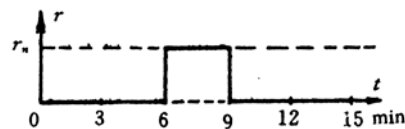
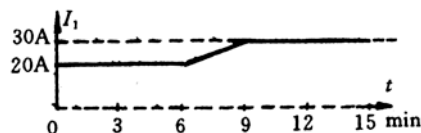

Fig. 9a



9b



9c

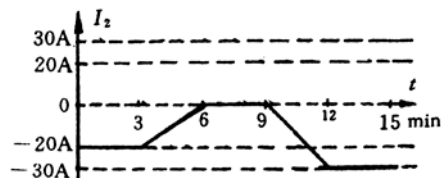

9d

Grading Scheme

Part 1, 2 points:

0.5 point for each of I_1 , I_2 from $t = t_1$ to t_3 and I_1 , I_2 from $t = t_3$ to t_4 .

Part 2, 3 points:

0.3 point for each of I_1 , I_2 from $t = 0$ to 1 min, I , I_1 , I_2 at $t = 1$ min,

and I_0 , I_1 , I_2 from $t = 1$ to 2 min;

0.2 point for each of I , I_1 , and I_2 from $t = 2$ to 3 min.

Part 3, 2 points:

0.25 point for each section in Fig. 8 from $t = 3$ to 9 min, 8 sections in total.

Part 4, 3 points:

0.25 point for each section in Fig. 9 from $t = 3$ to 12 min, 12 sections in total.

Theoretical Problem 3

COLLISION OF DISCS WITH SURFACE FRICTION

A homogeneous disc A of mass m and radius R_A moves translationally on a smooth horizontal x - y plane in the x direction with a velocity V (see the figure on the next page). The center of the disk is at a distance b from the x -axis. It collides with a stationary homogeneous disc B whose center is initially located at the origin of the coordinate system. The disc B has the same mass and the same thickness as A, but its radius is R_B . It is assumed that the velocities of the discs at their point of contact, in the direction perpendicular to the line joining their centers, are equal after the collision. It is also assumed that the magnitudes of the relative velocities of the discs along the line joining their centers are the same before and after the collision.

- 1) For such a collision determine the X and Y components of the velocities of the two discs after the collision, i. e. V'_{AX} , V'_{AY} , V'_{BX} and V'_{BY} in terms of m , R_A , R_B , V and b .
- 2) Determine the kinetic energies E'_A for disc A and E'_B for disc B after the collision in terms of m , R_A , R_B , V and b .

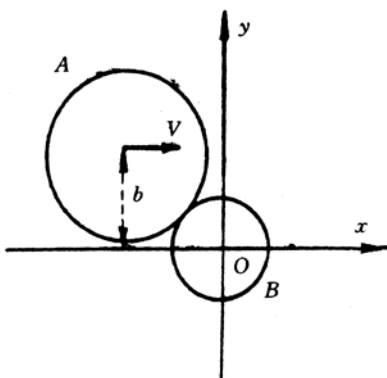

Theoretical Problem 3—Solution

1) When disc A collides with disc B, let n be the unit vector along the normal to the surfaces at the point of contact and t be the tangential unit vector as shown in the figure. Let φ be the angle between n and the x axis. Then we have

$$b = (R_A + R_B) \sin \varphi$$

The momentum components of A and B along n and t before collision are:

$$mV_{An} = mV \cos \varphi, \quad mV_{Bn} = 0,$$

$$mV_{At} = mV \sin \varphi, mV_{Bt} = 0.$$

Denote the corresponding momentum components of A and B after collision by mV'_{An} , mV'_{Bn} , mV'_{At} , and mV'_{Bt} . Let ω_A and ω_B be the angular velocities of A and B about the axes through their centers after collision, and I_A and I_B be their corresponding moments of inertia. Then,

$$I_A = \frac{1}{2}mR_A^2, \quad I_B = \frac{1}{2}mR_B^2$$

The conservation of momentum gives

$$mV \cos \varphi = mV'_{An} + mV'_{Bn}, \quad (1)$$

$$mV \sin \varphi = mV'_{At} + mV'_{Bt}, \quad (2)$$

The conservation of angular momentum about the axis through O gives

$$mVb = mV'_{At}(R_A + R_B) + I_A\omega_A + I_B\omega_B \quad (3)$$

The impulse of the friction force exerted on B during collision will cause a momentum change of mV'_{At} along t and produces an angular momentum $I_B\omega_B$ simultaneously. They are related by.

$$mV'_{Bt}R_b = I_B\omega_B \quad (4)$$

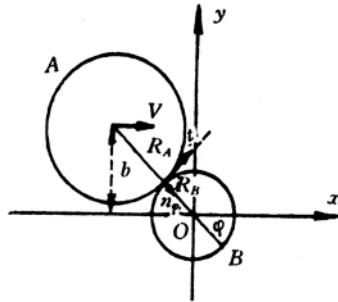

During the collision at the point of contact A and B acquires the same tangential velocities, so we have

$$V'_{At} - \omega_A R_A = V'_{Bt} - \omega_B R_B \quad (5)$$

It is given that the magnitudes of the relative velocities along the normal direction of the two discs before and after collision are equal, i. e.

$$V \cos \varphi = V'_{Bn} - V'_{An}. \quad (6)$$

From Eqs. 1 and 6 we get

$$V'_{An} = 0,$$

$$V'_{Bn} = V \cos \varphi.$$

From Eqs. 2 to 5, we get

$$V'_{At} = \frac{5}{6}V \sin \varphi,$$

$$V'_{Bt} = \frac{1}{6}V \sin \varphi,$$

$$\omega_A = \frac{V \sin \varphi}{3R_A},$$

$$\omega_B = \frac{V \sin \varphi}{3R_B}.$$

The x and y components of the velocities after collision are:

$$V'_{Ax} = V'_{An} \cos \varphi + V'_{At} \sin \varphi = \frac{5Vb^2}{6(R_A + R_B)^2}, \quad (7)$$

$$V'_{Ay} = -V'_{An} \sin \varphi + V'_{At} \cos \varphi = \frac{5Vb\sqrt{(R_A + R_B)^2 - b^2}}{6(R_A + R_B)^2}, \quad (8)$$

$$V'_{Bx} = V'_{Bn} \cos \varphi + V'_{Bt} \sin \varphi = \left[1 - \frac{5b^2}{6(R_A + R_B)^2} \right], \quad (9)$$

$$V'_{By} = -V'_{Bn} \sin \varphi + V'_{Bt} \cos \varphi = -\frac{5Vb\sqrt{(R_A + R_B)^2 - b^2}}{6(R_A + R_B)^2}, \quad (10)$$

2) After the collision, the kinetic energy of disc A is

$$E'_A = \frac{1}{2}m(V'^2_{Ax} + V'^2_{Ay}) + \frac{1}{2}I_A\omega_A^2 = \frac{3mV^2b^2}{8(R_A + R_B)^2} \quad (11)$$

while the kinetic energy of disc B is

$$E'_B = \frac{1}{2}m(V'^2_{Bx} + V'^2_{By}) + \frac{1}{2}I_B\omega_B^2 = \frac{1}{2}mV^2 \left[1 - \frac{11b^2}{12(R_A + R_B)^2} \right] \quad (12)$$

Grading Scheme

1. After the collision, the velocity components of discs A and B are shown in Eq. 7, 8, 9 and 10 of the solution respectively. The total points of this part is 8. 0. If the result in which all four velocity components are correct has not been obtained, the point is marked according to the following rules.

0.8 point for each correct velocity component;

0.8 point for the correct description of that the magnitudes of the relative velocities of the discs along the line joining their centers are the same before and after the collision.

0.8 point for the correct description of the conservation for angular momentum;

0.8 point for the correct description of the equal tangential velocity at the touching point;

0.8 point for the correct description of the relation between the impulse and the moment of the impulse.

2. After the collision, the kinetic energies of disc A and disc B are shown in Eqs. 11 and 12 of the solution respectively.

1.0 point for the correct kinetic energies of disc A;

1.0 point for the correct kinetic energies of disc B;

The total points of this part is 2.0

XXV INTERNATIONAL PHYSICS OLYMPIAD
BEIJING, PEOPLE'S REPUBLIC OF CHINA
PRACTICAL COMPETITION

July 15, 1994

Time available: 2.5 hours

READ THIS FIRST!

INSTRUCTIONS:

1. Use only the ball pen provided.
2. Your graphs should be drawn on the answer sheets attached to the problem.
3. Write your solution on the marked side of the paper only.
4. The draft papers are provided for doing numerical calculations and draft drawings.
5. Write at the top of every page:
 - The number of the problem
 - The number of the page of your report in each problem
 - The total number of pages in your report to the problem
 - Your name and code number

EXPERIMENTAL PROBLEM 1

Determination of light reflectivity of a transparent dielectric surface.

Experimental Apparatus

1. He-Ne Laser($\sim 1.5\text{mW}$). The light from this laser is not linearly polarized.
2. Two polarizers (\mathbf{P}_1 , \mathbf{P}_2) with degree scale disk (Fig. 1), one (\mathbf{P}_1) has been mounted in front of the laser output window as a polarizer, and another one can be fixed in a proper place of the drawing board by push-pins when it is necessary.
3. Two light intensity detectors (D_1 , D_2) which consisted of a photocell and a microammeter (Fig. 2).
4. Glass beam splitter(B).
5. Transparent dielectric plate, whose reflectivity and refractive index are to be determined.
6. Sample table mounted on a semicircular degree scale plate with a coaxial swivel arm(Fig. 3).
7. Several push-pins for fixing the sample table on the drawing board and as its rotation axis.
8. Slit aperture and viewing screen for adjusting the laser beam in the horizontal direction and for alignment of optical elements.
9. Lute for adhere of optical elements in a fixed place.
10. Wooden drawing board.
11. Plotting papers

Experiment Requirement

1. Determine the reflectivity of the p -component as a function of the incident angle (the electric field component, parallel to the plane of incidence is called the p -component).
 - (a) Specify the transmission axis of the polarizer (A) by the position of the marked line on the degree scale disk in the p -component measurement(the transmission axis is the direction of vibration of the electric field vector of the transmitted light).
 - (b) Choose any one of the light intensity detector and set its micro-ammeter at the range of " $\times 5$ ". Verify the linear relationship between the light intensity and the micro-ammeter reading. Draw the optical schematic diagram. Show your measured data and calculated results(including the calculation formula)in the form of a table. Plot the linear relationship curve.

- (c) Determine the reflectivity of the p -component as a function of the incident angle. Draw the optical schematic diagram. Show your measured data and calculated reflectivity(including the calculation formula)in the form of a table. Plot the reflectivity as a function of the incident angle.

2. Determine the refractive index of the sample as accurate as possible.

Explanation and Suggestion

1. Laser radiation avoid direct eye exposure.
2. Since the output power of the laser beam may fluctuate from time to time, the fluctuation of light output has to be monitored during the performance of the experiment and a correction of the experimental results has to be made.
3. The laser should be lighting all the time, even when you finish your experiment and leave the examination hall, the laser should be keeping in work.
4. The reflected light is totally plane polarized at an incident angle θ_B while $\text{tg } \theta_B = n$ (refractive index).

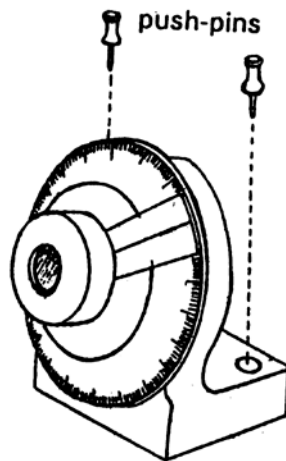

Fig. 1 polarizers with degree scale disk

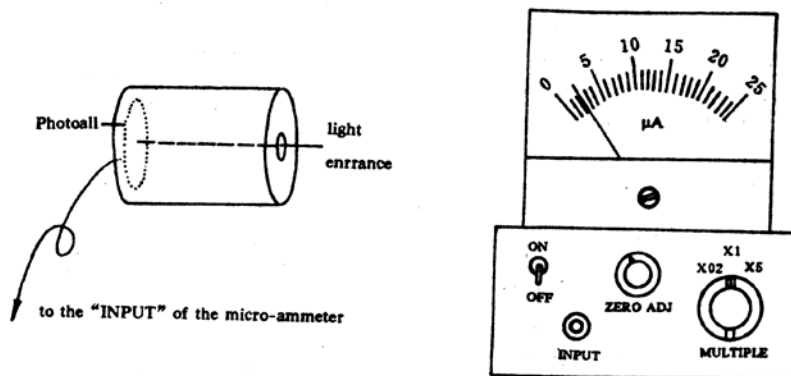

Fig. 2 Light intensity detector

- (1) Insert the plug of photocell into the “INPUT” socket of microammeter
- (2) Switching on the microammeter.
- (3) Block off the light entrance hole in front of the photocell and adjust the scale reading of micro ammeter to “0”.
- (4) Set the “Multiple” knob to a proper range.

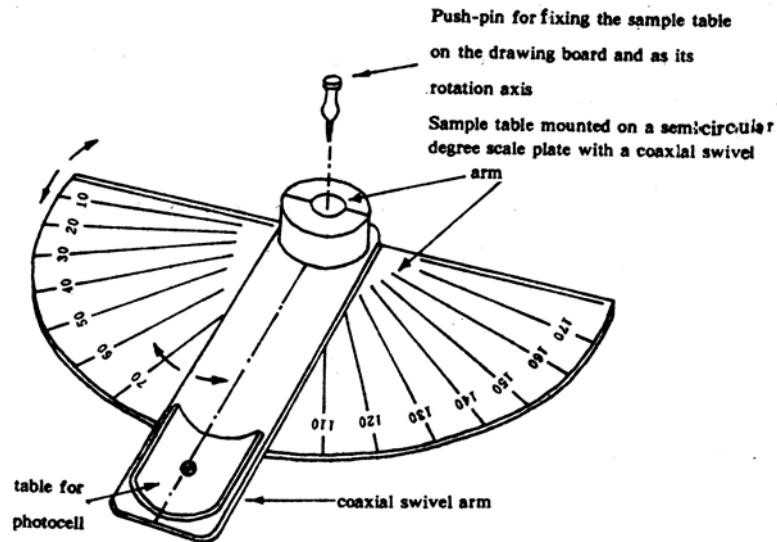
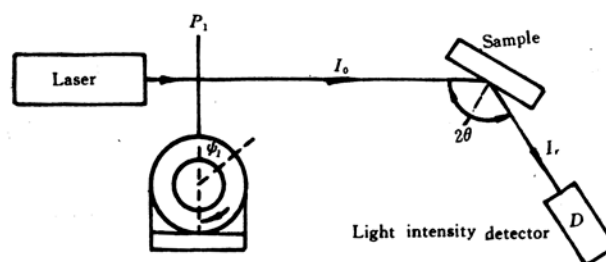

Fig.3 Sample table mounted on a semicircular degree scale plate

Experimental Problem 1—Solution

1. (a) Determine the transmission axis of the polarizer and the Brewster angle θ_B of the sample by using the fact that the reflectivity of the p -component $R_p = 0$ at the Brewster angle.

Change the orientation of the transmission axis of P_1 , specified by the position of the marked line on the degree scale disk (ψ) and the incident angle (θ_i) successively until the related intensity $I_r = 0$.



Now the incident light consists of p -component only and the incident angle is θ_B , the

corresponding values ψ_1 and θ_B are shown below:

ψ_1	140.0°	322.0°	141.0°	322.5°
θ	56.4°	56.4°	56.2°	56.2°

$$\psi_1 = 140.5^\circ \pm 0.5^\circ \quad \text{or} \quad 322.3^\circ \pm 0.1^\circ$$

The Brewster angle θ_B is $56.3^\circ \pm 0.1^\circ$

- (b) Verification of the linear relationship between the light intensity and the microammeter reading.

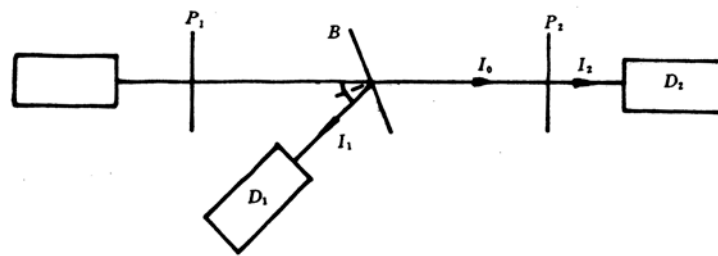

The intensity of the transmitted light passing through two polarizers P_1 and P_2 obeys Malus' law

$$I(\theta) = I_0 \cos^2 \theta$$

where I_0 is the intensity of the light polarized by p_1 and incident, I is the intensity of the transmitted light, and θ is the angle between the transmission axes of P_1 and P_2 . Thus we can obtain light with various intensities for the verification by using two polarizers.

The experimental arrangement is shown in the figure.

The light intensity detector D_1 serves to monitor the intensity fluctuation of the incident beam (the ratio of I_1 to I_2 remain unchanged), and D_2 measures I_2 . Let $i_1(\theta)$ and $i_2(\theta)$ be the readings of D_1 and D_2 respectively, and $\psi_2(\theta)$ be the reading of the marked line position. $i_2 = 0$ when $\theta = 90^\circ$, the corresponding ψ_2 is $\psi_2(90^\circ)$, and the value of θ corresponding to ψ_2 is

$$\theta = |\psi_2 - \psi_2(90^\circ) \pm 90^\circ|$$

Data and results;

$$\psi_2(90^\circ) = 4^\circ$$

ψ_2	94.0°	64.0°	49.0°	34.0°	4.0°
θ	0.0°	30.0°	45.0°	60.0°	90.0°
$i_1(\theta)\mu A$	6.3×1	5.7×1	5.7×1	5.7×1	5.7×1
$i_2(\theta)\mu A$	18.7×5	12.7×5	8.2×5	4.0×5	0.0×5

From the above data we can obtain the values of $I(\theta)/I_2(\theta)$ from the formula

$$\frac{I(\theta)}{I_0} = \frac{i_2(\theta)}{i_1(\theta)} \cdot \frac{i_1(0)}{i_2(0)}$$

and compare them with $\cos^2 \theta$ for examining the linear relationship. The results obtained are:

θ	0.0°	30.0°	45.0°	60.0°	90.0°
$\cos^2 \theta$	1.00	0.75	0.50	0.25	0.00
$I(\theta)/I_0$	1.00	0.75	0.49	0.24	0.00

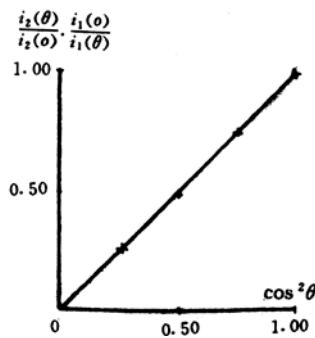

1. (c) Reflectivity measurement

The experimental arrangement shown below is used to determine the ratio of I_0 to I_1 which is proportional to the ratio of the reading (i_{20}) of D_2 to the corresponding reading (i_{10}) of D_1 .

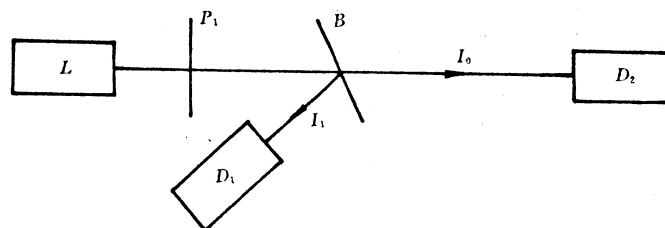

Then used the experimental arrangement shown below to measure the reflectivity R_p of the sample at various incident angle (θ) while the incident light consists of p -component only. Let $i_1(\theta)$ and $i_2(\theta)$ be the readings of D_1 and D_2 respectively.

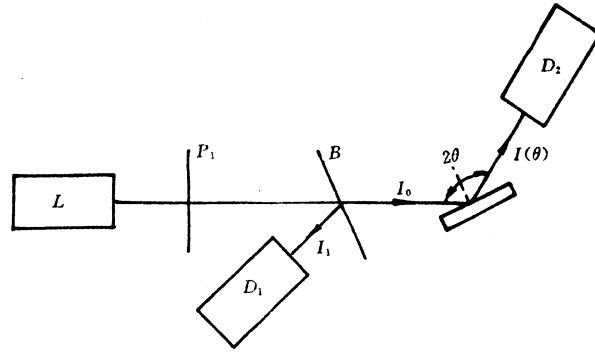

Then the reflectivity is

$$R_p(\theta) = \frac{I(\theta)}{I_0} = \frac{i_2(\theta)}{i_1(\theta)} \cdot \frac{i_{10}}{i_{20}}$$

Data and results:

$$\psi_1 = 140.5^\circ$$

$$i_{20} = 19.8 \times 5 \mu A$$

$$i_{10} = 13.3 \mu A$$

$\theta (^{\circ})$	$i_2(\theta)$	$i_1(\mu A)$	$R_p(\theta)$
5	15.1×0.2	11.1	0.037
10	14.9×0.2	11.2	0.036
20	13.3×0.2	11.1	0.032
30	11.4×0.2	12.2	0.025
40	7.8×0.2	14.7	0.014
50	2.3×0.2	16.9	0.0037
53	0.7×0.2	11.3	0.0017
55	0.3×0.2	11.3	0.00059
56.3 (dark)	~ 0	11.5	~ 0
58	0.3×0.2	11.5	0.0007
60	1.1×0.2	13.5	0.0024
64	6.5×0.2	16.7	0.011
66	7.8×0.2	11.8	0.018
68	16.3×0.2	15.0	0.029

72	5.3×0.1	11.7	0.061
76	13.1×1	14.0	0.13
80	4.4×5	11.7	0.25
84	9.1×5	14.5	0.42

The curve of reflectivity of p-component as a function of incident in plexiglass

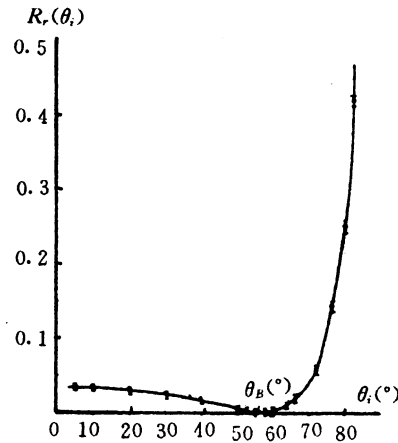

2. The Brewster angle θ_B can be found from the above data as

$$\theta_B = 56.3^\circ \pm 0.2^\circ$$

The index of refraction can be calculated as

$$n = \tan \theta_B = 1.50 \pm 0.01$$

The sources of errors are:

1. Detector sensitivity is low.
2. The incident light does not consist of p -component only.
3. The degree scales are not uniform.

EXPERIMENTAL PROBLEM 1: Grading Scheme(10 points)

Part 1. Reflectivity of the p -component. 7 points, distributed as follows.

- a. Determination of the transmission axis of the polarizer (A) in p -component measurement, 1 point.

(Error less than $\pm 2^\circ$, 1.0point;
error less than $\pm 3^\circ$, 0.7point;
error less than $\pm 4^\circ$, 0.3point;
error less than $\pm 5^\circ$, 0.1 point.)

- b. Verification of the linearity of the light intensity detector(2 points). Draws the optical schematic diagram correctly, 1.0 point; (Without the correction of the fluctuation of the light intensity, 0.4 point only);

Uses $I/I_0 \sim \cos^2 \theta$ figure to show the “linearity”, 0.5 point;

Tabulate the measured data(with 5 points at least)correctly, 0.5 point.

- c. Determination of the reflectivity of the p-component of the light as a function of incident angle, 4 points, distributed as follows.

Draws the optical schematic diagram correctly and tabulate the measured data perfectly, 2.0 points;

Plot the reflectivity as the function of incident angle with indication of errors, 2 points.

Part 2. Determination of the refractive index of sample, 3 point.

Brewster angle of sample, 1 point;

(Error less than $\pm 1^\circ$, 1.0point;

error less than $\pm 2^\circ$, 0.5point;

error less than $\pm 3^\circ$, 0.2point;

error larger than $\pm 3^\circ$, 0 point.)

The refractive index of sample, 0.5 point.

Discussion and determination of errors, 1.5 points.

EXPERIMENTAL PROBLEM 2

Black Box

Given a black box with two similar terminals. There are no more than three passive elements inside the black box. Find the values of elements in the equivalent circuit between the terminals. This box is not allowed to be opened.

Experimental Apparatus

1. Double channel oscilloscope with a panel illustration, showing the name and function of each knob

2. Audio frequency signal generator with a panel illustration, showing the name and function of each knob

3. Resistance box with a fixed value of 100 ohm($< \pm 0.5\%$)

4. Several connecting wires

5. For the coaxial cables, the wire in black color at the terminal is grounded.

6. Log-log paper, semi-log paper, and millimeter paper are provided for use if necessary

Note: The knobs, which were not shown on the panel illustration of the “signal generator” and “oscilloscope”, have been set to the correct positions. It should not be touched by the student.

Experimental Requirements

1. Draw the circuit diagram in your experiment.

2. Show your measured data and the calculated results in the form of tables. Plot the experimental curves with the obtained results on the coordinate charts provided(indicate the title of the diagram and the titles and scale units of the coordinate axes)
3. Given the equivalent circuit of the black box and the names of the elements with their values in the equivalent circuit(write down the calculation formulas).

Instructions

1. Do your experiment in the frequency range between 100 Hz and 50kHz.
2. The output voltage of the signal generator should be less than 1.0V (peak-to-peak). Set the “Out Attenuation” switch to “20” db position and it should not be changed.
3. On connecting the wires, be careful to manage the wiring so as to minimize the 50Hz interference from the electric mains.

Instruction for Using XD2 Type Frequency Generator

1. Set the “Out Attenuation” to “20” db position and it should not be changed.
2. Set the “Damping Switch” to “Fast” position.
3. The indication of the voltmeter of the signal generator is the relative value, but not the true value of the output.
4. Neglect the error of the frequency readings.

Note: For XD22 Type Audio Frequency generator, there is no “Damping Switch”, and the “output” switch should be set to the sine “~” position.

Instruction for Using SS-5702 Type Oscilloscope

1. Keep the “V mode” switch in “Dual” position.
2. The “Volts/div” (black) and the “variable control” (red) vary the gain of the vertical amplifier, and when the “variable control” (red) is in the fully clockwise position, the black setting are calibrated.
3. The “Times/div” (Black) varies the horizontal sweep rate from 0.5 μ s/div to 0.2s/div, and they are calibrated when the “variable control” (red) is in the fully clockwise CAL position.
4. The “Triggering Source” (Triggering sweep signal) is used to select the triggering signal channel and the " level" control is used to adjust the amplitude of the triggering signal.
5. Measuring accuracy: $\pm 4\%$.

Instruction for Using “Resistance Box”

The resistance of the “Resistance Box” has been set to a value of 100ohm, and it should not be changed.

Experimental problem 2..... Solution

1. The circuit diagram is shown in Fig. 1

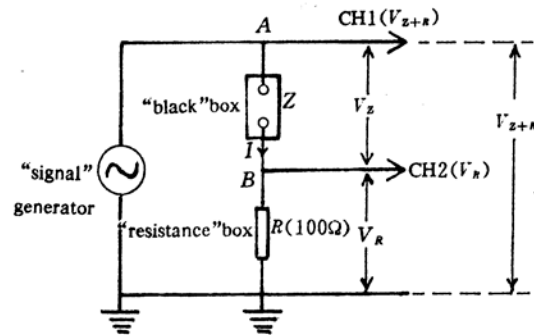

Fig. 1

We have the relation:

$$I = \frac{V_R}{R};$$

$$Z + R = \frac{V_{Z+R}}{I} = \frac{V_{Z+R}}{V_R} R$$

2. Measure the values of V_{Z+R} and V_R at various frequencies (f), the measured data and calculated value of $Z+R$ are shown in table 1. "The $Z+R$ - f curve is plotted in Fig. 2

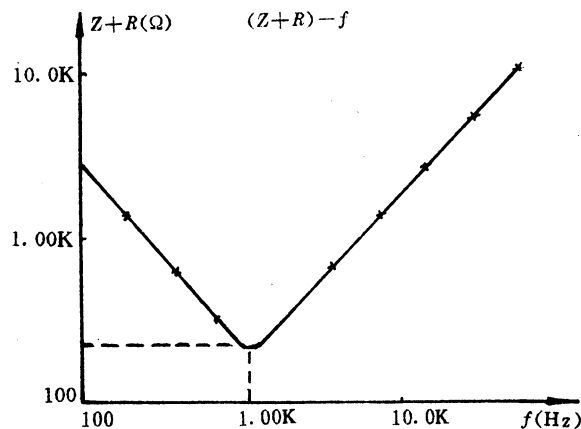

Table 1. The magnitude of impedance versus frequency

$f(\times 10^3 \text{ Hz})$	$U_{Z+R}(V_{pp})$	$U_R \text{ mV}_{pp}$	$Z + R(\times 10^3 \Omega)$
0.100	0.600	22.0	2.73
0.200	0.600	45.0	1.33
0.400	0.600	94.0	0.638
0.700	0.300	92.0	0.326
0.900	0.300	121	0.248

1.00	0.300	136	0.220
1.10	0.300	140	0.214
1.16	0.300	141	0.213
1.25	0.300	140	0.214
1.50	0.300	120	0.250
2.00	0.300	88.0	0.341
4.00	0.300	78.0	0.769
8.00	0.600	38.0	1.58
15.0	0.600	20.0	3.00
30.0	0.600	10.0	6.00
50.0	0.600	6.0	10.0

From table 1 and Fig. 2, we got the conclusions:

- (1) Current resonance (minimum of Z) occurs at $f_0 \cong 1.16 \times 10^3$ Hz.
- (2) $f \ll f_0$, $Z \propto f$, $\Delta\phi \approx -\pi/2$. The impedance of the “black box” at low frequency is dominated by a inductance.
- (3) $f \gg f_0$, $Z \propto f$, $\Delta\phi \approx \pi/2$. The impedance of the “black box” at high frequency is dominated by a inductance.
- (4) Equivalent circuit of the “black box”; r , L and C connected in series shown in Fig. 3.

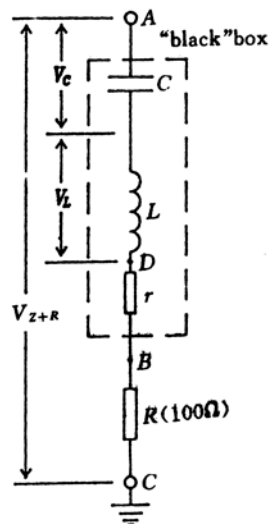

Fig. 3

3. Determination of the values of r , L and C .

(a) r

At resonance frequency f_0

$$V_C = -V_L$$

Then

$$Z + R = \frac{V_{Z+R}}{I} = \frac{V_{Z+R}}{V_R} R = r + R$$

From table 1, $r + R = 213\Omega$, it is given $R = 100\Omega$, so the equivalent resistance r in Fig. 3 is equal 113Ω .

(b) C

At low frequency, $z_L \approx 0$ in Fig. 3. So the circuit could be considered as a series RC circuit.

From phasor diagram, Fig. 4,

$$\frac{1}{\omega C} = Z_C = \frac{V_C}{I} = \frac{\sqrt{V_{Z+R}^2 - V_{R+r}^2}}{I}$$

Since $V_{R+r}^2 / V_{Z+R}^2 \approx 6 \times 10^{-3}$ at $f = 100$ Hz, V_{R+r}^2 can be neglected with respect to V_{Z+R}^2 , so

$$\frac{1}{\omega C} \approx \frac{V_{Z+R}}{I} \approx Z + R = 2.73 \times 10^3 \Omega$$

$$C \approx \frac{1}{\omega(Z + R)} = 0.58 \mu f .$$

$$C \cong 0.58 \mu f .$$

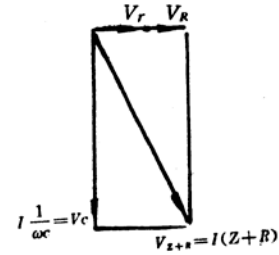

Fig. 4

(c) L

At high frequency, $Z_L \approx 0$ in Fig. 3. So the circuit could be considered as a series RL circuit.

From phasor diagram, Fig. 5,

$$|V_L| = \sqrt{V_{Z+R}^2 - V_{r+R}^2} ,$$

Since $V_{r+R}^2 / V_{Z+R}^2 \approx 4.5 \times 10^{-4}$ at $f = 50$ kHz, V_{r+R}^2 can be neglected with respect to V_{Z+R}^2 , so

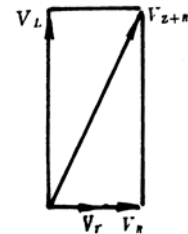

Fig. 5

$$\omega L = Z_L = \frac{V_L}{I} = \frac{|V_{Z+R}|}{I} \approx Z + R = 10^4 \Omega \quad (3)$$

$$L = \frac{Z + R}{\omega} = 31.8 \text{ mH.}$$

Error estimation:

It is given, precision of the resistance box reading $\Delta R / R \approx 0.5\%$

precision of the voltmeter reading $\Delta V / V \approx 4\%$

(1) Resistance r : at resonance frequency f_0

$$r + R = \frac{V_{Z+R}}{V_R} R$$

$$\frac{\Delta(r + R)}{r + R} = \frac{\Delta V_{Z+R}}{V_{Z+R}} + \frac{\Delta V_R}{V_R} + \frac{\Delta R}{R} \approx 4\% + 4\% + 0.5\% = 8.5\%$$

$$\Delta r = 16\Omega$$

(2) Capacitance C: (Neglect the error of the frequency reading)

$$\frac{1}{\omega C} \cong Z_C = \frac{V_{Z+R}}{V_R} R$$

$$\frac{\Delta C}{C} = \frac{\Delta V_{Z+R}}{V_{Z+R}} + \frac{\Delta V_R}{V_R} + \frac{\Delta R}{R} \approx 8.8\%$$

The approximation $V_C \approx V_{Z+R}$ will introduce a percentage error 0.3%

(3) Inductance L: Similar to the results of capacitance C, but the percentage error introduced by the approximation $V_L \approx V_{Z+R}$ is much small (0.003%) and thus negligible.

$$\frac{\Delta L}{L} \approx 8.5\% .$$

Experimental Problem 2: Grading Scheme (10 points maximum)

1. Measuring circuit is correct as shown in Fig.(a)

.....2.0point

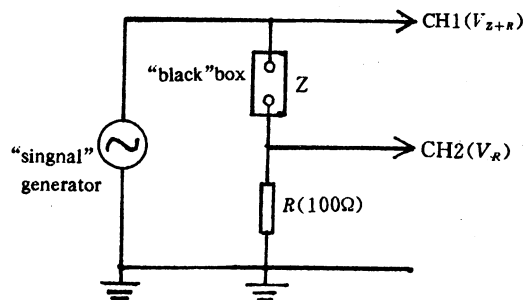

Fig. a

2. Correct data table and figure to show the characteristic of the black box

.....2.0 points

3. The equivalent circuit of the black box, and the names of the elements with their values in the equivalent circuit are correct

total 6.0 points

(a) R, L and C are connected in series

.....1.5 point

(L and C are connected in series

.....1.0 point)

(b) Correct value (error less than 15%) for each element

.....0.5 point (× 3)

(error between 15% and 30% 0.3)

(error between 30% and 50% 0.1)

(c) Correct calculation formula for each element

.....0.5 point (× 3)

(d) Error estimate is reasonable for each element

.....0.5 points (× 3)

□□□□□□□□

Theoretical Question 1

This is essentially a question in special relativity. The core of the question is part (b) which involves a simulated experiment. It requires students to combine the concepts of gravitational red shifts, resonance absorption, Doppler shifts and the graphical interpretation of data.

Overall the question appears to have met its objective of allowing nearly all students to gain a few marks from part (a). A surprisingly large number of students were able to obtain essentially the correct solution to part (b) using the appropriate straight-line graph. Part (c) also produced many basically correct solutions with some of the best students simplifying their solution to the logical limit. One student managed to obtain the correct answer making use of the 4-momentum. The very best answers to this question were almost flawless and demonstrated a very high level of conceptual understanding and the ability to synthesise ideas from a number of different areas.

Theoretical Question 2

This question is concerned with the propagation of waves in a medium with a varying refractive index and the different modes of propagation which occur. The responses to this question mirrored the marks distribution shown in Figure 1 for the overall theory results. A number of students gained near-perfect marks while an equivalent number gained very few. The most interesting part of the marking arose in connection with part (a), where the arc radius R specified in the question needs to be established. The marking team encountered four distinguishable and valid approaches to establishing the result for R .

Part (c) proved to be a useful discriminator between those students who either did, or did not, realise that a series of paths, or modes, exists from the source to the receiver. The numerical estimates in part (d), and intended to assist the markers, required some care in marking according to the way in which students treated the issue of significant figures during the calculation. Part (e), which led to the conclusion that the ray with the smallest value of initial angle will arrive first, was a useful discriminator.

Theoretical Question 3

This question is essentially a problem in mechanics with elements of hydrostatics. It involves the concepts of Archimedes' Principle, small oscillations and rotational dynamics applied to an interesting geometry.

One common mistake of interpretation noted by the examiners was to set the length of the rod equal to the radius rather than to the diameter of the cylinder. In line with the policy on marking, students were only penalised once for this mistake provided that the rest of their analysis was consistent with this assumption. The clever aspect of the problem was in part (d) where some students attempted to estimate the solution to the transcendental equation $\alpha - \sin \alpha \cos \alpha = 1.61 \sin \alpha$, rather than simply checking that $\alpha \simeq 1.57(\pi/2)$ gave a reasonable result. Students from two teams used numerical methods to obtain a more precise value for α . One student who correctly applied Newton's method to solve the equation for α received the special prize for mathematics.

Experimental Question 1

This question was concerned with the motion of small objects (cylinders) in a viscous medium, and was designed to test as wide a range of experimental skills as possible. In particular the question aimed to test:

- understanding of the concept of terminal velocity.
- experimental technique; the experiment required careful hand-eye coordination to reduce systematic effects (for example by dropping the cylinders each time with the same orientation and using multiple timings to reduce the scatter in the results).
- the ability to graph and interpret data including the use of logarithmic and linear plots and the interpretation of slopes and intercepts.
- estimation of uncertainties in the results.

The experiment generally worked as expected. Experimental techniques were uniformly good, and the students demonstrated excellent manipulative skills. Their main weakness was in the handling of the determination of the density of the glycerine from the graph of fall time as a function of the density of the cylinders. Students in general did not measure the intercept on the density axis but calculated the density from the intercept on the fall time axis and the slope of the graph.

Experimental Question 2

This question made use of a laser pointer to carry out several experiments in optics. The first task concerned the use of a metal ruler as a diffraction grating. In this experiment the diffraction pattern was formed by reflection with the incident laser beam at nearly normal incidence to the ruler. (This geometry is rather different from the more common demonstration where the incident beam is at close to grazing incidence.) A number of students had difficulty with this geometry and failed to obtain a convincing pattern.

The second experiment investigated the reflection and transmission of light through transparent media. The main difficulty with the measurements was that changes in intensity had to be estimated by eye using a set of calibrated transmission discs. This was much more demanding than using, for example, a photodiode and multimeter as it required the exercise of considerable experimental judgement. It therefore provided an excellent test of a student's experimental technique.

The final experiment was concerned with the scattering of light from a translucent material formed by adding a few drops of milk to water. The amount of scattering and the reduction in the transmitted intensity were measured as a function of the concentration of milk. Students had considerable difficulty with this experiment with some not recognising the phenomena they were meant to be observing. However the best students were still able to obtain convincing results. The exercise therefore provided good discrimination between the most able students.

Theoretical Question 1

Gravitational Red Shift and the Measurement of Stellar Mass

(a) (3 marks)

A photon of frequency f possesses an effective inertial mass m determined by its energy. Assume that it has a gravitational mass equal to this inertial mass. Accordingly, a photon emitted at the surface of a star will lose energy when it escapes from the star's gravitational field. Show that the frequency shift Δf of the photon when it escapes from the surface of the star to infinity is given by

$$\frac{\Delta f}{f} \simeq -\frac{GM}{Rc^2}$$

for $\Delta f \ll f$ where:

- G = gravitational constant
- R = radius of the star
- c = velocity of light
- M = mass of the star.

Thus, the red-shift of a known spectral line measured a long way from the star can be used to measure the ratio M/R . Knowledge of R will allow the mass of the star to be determined.

(b) (12 marks)

An unmanned spacecraft is launched in an experiment to measure both the mass M and radius R of a star in our galaxy. Photons are emitted from He^+ ions on the surface of the star. These photons can be monitored through resonant absorption by He^+ ions contained in a test chamber in the spacecraft. Resonant absorption occurs only if the He^+ ions are given a velocity towards the star to allow exactly for the red shifts.

As the spacecraft approaches the star radially, the velocity relative to the star ($v = \beta c$) of the He^+ ions in the test chamber at absorption resonance is measured as a function of the distance d from the (nearest) surface of the star. The experimental data are displayed in the accompanying table.

Fully utilize the data to determine graphically the mass M and radius R of the star. There is no need to estimate the uncertainties in your answer.

Data for Resonance Condition

Velocity parameter	$\beta = v/c$ ($\times 10^{-5}$)	3.352	3.279	3.195	3.077	2.955
Distance from surface of star	d ($\times 10^8 \text{m}$)	38.90	19.98	13.32	8.99	6.67

(c) (5 marks)

In order to determine R and M in such an experiment, it is usual to consider the frequency correction due to the recoil of the emitting atom. [Thermal motion causes emission lines to be broadened without displacing emission maxima, and we may therefore assume that all thermal effects have been taken into account.]

(i) (4 marks)

Assume that the atom decays at rest, producing a photon and a recoiling atom. Obtain the relativistic expression for the energy hf of a photon emitted in terms of ΔE (the difference in rest energy between the two atomic levels) and the initial rest mass m_0 of the atom.

(ii) (1 mark)

Hence make a numerical estimate of the relativistic frequency shift $\left(\frac{\Delta f}{f}\right)_{\text{recoil}}$ for the case of

He^+ ions.

Your answer should turn out to be much smaller than the gravitational red shift obtained in part (b).

Data:

Velocity of light	c	=	$3.0 \times 10^8 \text{ms}^{-1}$
Rest energy of He	$m_0 c^2$	=	$4 \times 938 (\text{MeV})$
Bohr energy	E_n	=	$-\frac{13.6 Z^2}{n^2} (\text{eV})$
Gravitational constant	G	=	$6.7 \times 10^{-11} \text{Nm}^2 \text{kg}^{-2}$

Theoretical Question 2

Sound Propagation

Introduction

The speed of propagation of sound in the ocean varies with depth, temperature and salinity. Figure 1(a) below shows the variation of sound speed c with depth z for a case where a minimum speed value c_0 occurs midway between the ocean surface and the sea bed. Note that for convenience $z = 0$ at the depth of this sound speed minimum, $z = z_S$ at the surface and $z = -z_b$ at the sea bed. Above $z = 0$, c is given by

$$c = c_0 + bz \quad .$$

Below $z = 0$, c is given by

$$c = c_0 - bz \quad .$$

In each case $b = \left| \frac{dc}{dz} \right|$, that is, b is the magnitude of the sound speed gradient with depth; b is assumed constant.

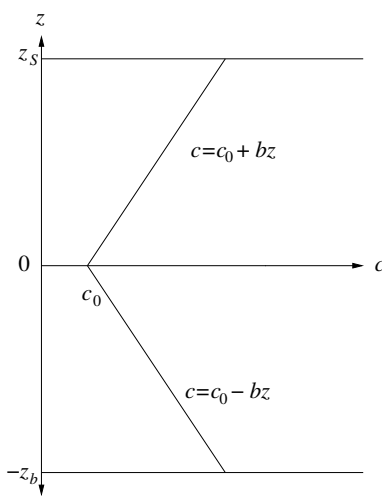

Figure 1 (a)

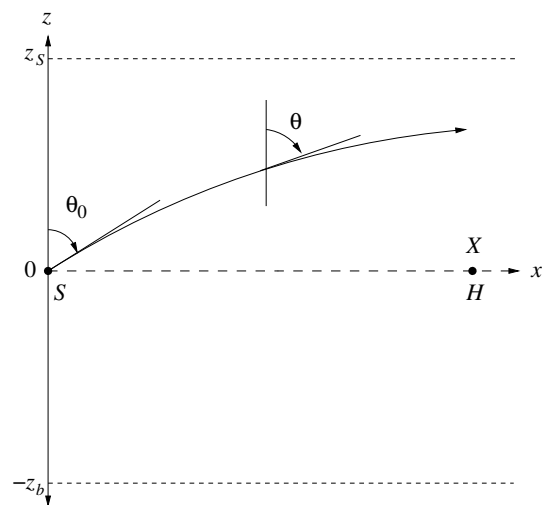

Figure 1 (b)

Figure 1(b) shows a section of the z - x plane through the ocean, where x is a horizontal direction. The variation of c with respect to z is shown in figure 1(a). At the position $z = 0$, $x = 0$, a sound source S is located. A 'sound ray' is emitted from S at an angle θ_0 as shown. Because of the variation of c with z , the ray will be refracted.

(a) (6 marks)

Show that the trajectory of the ray, leaving the source S and constrained to the z - x plane forms an arc of a circle with radius R where

$$R = \frac{c_0}{b \sin \theta_0} \quad \text{for } 0 \leq \theta_0 < \frac{\pi}{2} \quad .$$

(b) (3 marks)

Derive an expression involving z_S , c_0 and b to give the smallest value of the angle θ_0 for upwardly directed rays which can be transmitted without the sound wave reflecting from the sea surface.

(c) (4 marks)

Figure 1(b) shows the position of a sound receiver H which is located at the position $z = 0$, $x = X$. Derive an expression involving b , X and c_0 to give the series of angles θ_0 required for the sound ray emerging from S to reach the receiver H . Assume that z_S and z_b are sufficiently large to remove the possibility of reflection from sea surface or sea bed.

(d) (2 marks)

Calculate the smallest four values of θ_0 for refracted rays from S to reach H when

- $X = 10000$ m
- $c_0 = 1500$ ms⁻¹
- $b = 0.02000$ s⁻¹

(e) (5 marks)

Derive an expression to give the time taken for sound to travel from S to H following the ray path associated with the **smallest** value of angle θ_0 , as determined in part (c). Calculate the value of this transit time for the conditions given in part (d). The following result may be of assistance:

$$\int \frac{dx}{\sin x} = \ln \tan \left(\frac{x}{2} \right)$$

Calculate the time taken for the direct ray to travel from S to H along $z = 0$. Which of the two rays will arrive first, the ray for which $\theta_0 = \pi/2$, or the ray with the smallest value of θ_0 as calculated for part (d)?

Theoretical Question 3

Cylindrical Buoy

(a) (3 marks)

A buoy consists of a solid cylinder, radius a , length l , made of lightweight material of uniform density d with a uniform rigid rod protruding directly outwards from the bottom halfway along the length. The mass of the rod is equal to that of the cylinder, its length is the same as the diameter of the cylinder and the density of the rod is greater than that of seawater. This buoy is floating in sea-water of density ρ .

In equilibrium derive an expression relating the floating angle α , as drawn, to d/ρ . Neglect the volume of the rod.

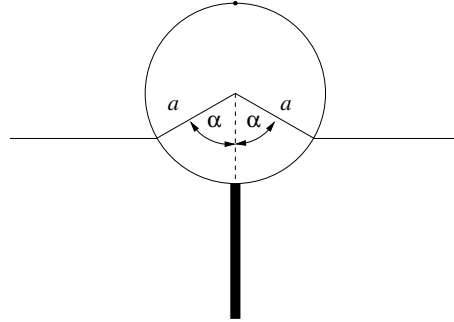

(b) (4 marks)

If the buoy, due to some perturbation, is depressed vertically by a small amount z , it will experience a nett force, which will cause it to begin oscillating vertically about the equilibrium floating position. Determine the frequency of this vertical mode of vibration in terms of α , g and a , where g is the acceleration due to gravity. Assume the influence of water motion on the dynamics of the buoy is such as to increase the effective mass of the buoy by a factor of one third. You may assume that α is not small.

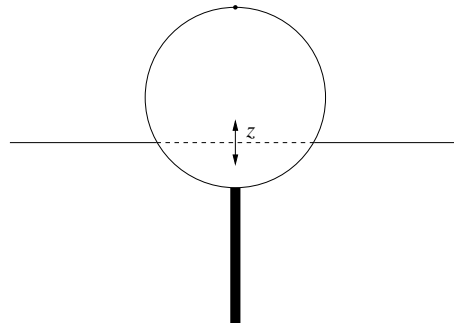

(c) (8 marks)

In the approximation that the cylinder swings about its horizontal central axis, determine the frequency of swing again in terms of g and a . Neglect the dynamics and viscosity of the water in this case. The angle of swing is assumed to be small.

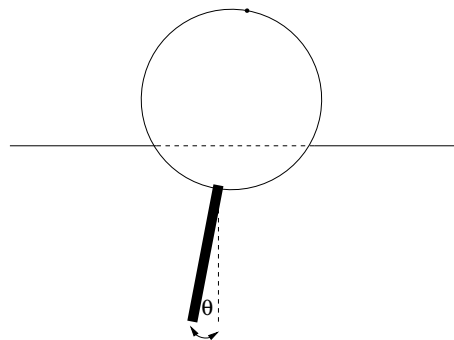

(d) (5 marks)

The buoy contains sensitive accelerometers which can measure the vertical and swinging motions and can relay this information by radio to shore. In relatively calm waters it is recorded that the vertical oscillation period is about 1 second and the swinging oscillation period is about 1.5 seconds. From this information, show that the floating angle α is about 90° and thereby estimate the radius of the buoy and its total mass, given that the cylinder length l equals a .

[You may take it that $\rho \simeq 1000 \text{ kgm}^{-3}$ and $g \simeq 9.8 \text{ ms}^{-2}$.]

Original Theoretical Question 3

The following question was not used in the XXVI IPhO examination.

Laser and Mirror

(a)

Light of frequency f_i and speed c is directed at an angle of incidence θ_i to the normal of a mirror, which is receding at speed u in the direction of the normal. Assuming the photons in the light beam undergo an elastic collision *in the rest frame of the mirror*, determine in terms of θ_i and u/c the angle of reflection θ_r of the light and the reflected frequency f_r , with respect to the original frame.

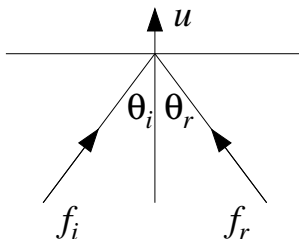

[You may assume the following Lorentz transformation rules apply to a particle with energy E and momentum \mathbf{p} :

$$p_{\perp} = p_{\perp}, \quad p_{\parallel} = \frac{p_{\parallel} - vE/c^2}{\sqrt{1 - v^2/c^2}}, \quad E = \frac{E - vp_{\parallel}}{\sqrt{1 - v^2/c^2}},$$

where \mathbf{v} is the relative velocity between the two inertial frames; p_{\perp} stands for the component of momentum perpendicular to \mathbf{v} and p_{\parallel} represents the component of momentum parallel to \mathbf{v} .]

(b)

A thin rectangular light mirror, perfectly reflecting on each side, of width $2a$ and mass m , is mounted in a vacuum (to eliminate air resistance), on essentially frictionless needle bearings, so that it can rotate about a vertical axis. A narrow laser beam operating continuously with power P is incident on the mirror, at a distance b from the axis, as drawn.

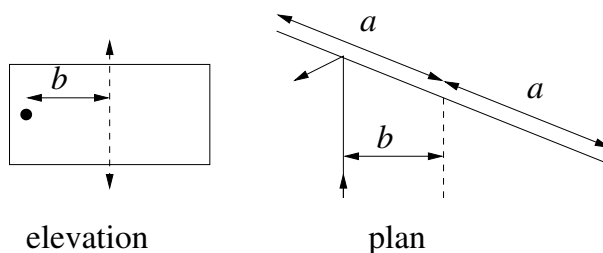

Suppose the mirror is originally at rest. The impact of the light causes the mirror to acquire a very small but not constant angular acceleration. To analyse the situation approximately, assume that at any given stage in the acceleration process the angular velocity ω of the mirror is constant throughout any one complete revolution, but takes on a slightly larger value in the next revolution due to the angular momentum imparted to the mirror by the light during the preceding revolution. Ignoring second order terms in the ratio (mirror velocity / c), calculate this increment of angular momentum per revolution at any given value of ω . [HINT: You may find it useful to know that $\int \sec^2 \theta \, d\theta = \tan \theta$.]

(c)

Using the fact that the velocity of recoil of the mirror remains small compared with c , derive an approximate expression for ω as a function of time.

(d)

As the mirror rotates, there will be instants when the light is reflected from its edge, giving the reflected ray an angle of somewhat more than 90° with respect to the incident beam.. A screen 10 km away, with its normal perpendicular to the incident beam, intercepts the beam reflected from near the mirror's edge. Find the deviation ξ of that extreme spot from its initial position (as shown by the dashed line, when the mirror was almost at rest), after the laser has operated for 24 hours. You may suppose the laser power is $P = 100$ W, that the mirror has mass $m = 1$ gram and that the geometry of the apparatus corresponds to $a = b\sqrt{2}$. Neglect diffraction effects at the edge.

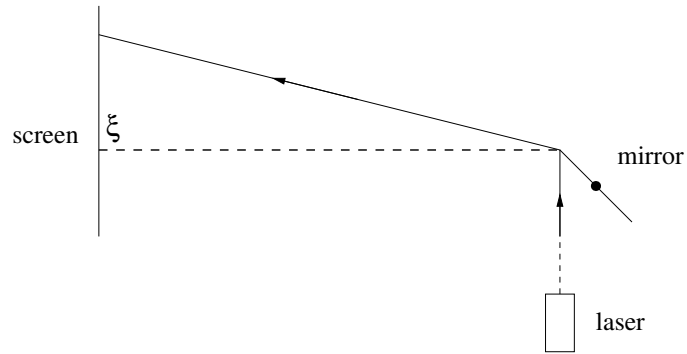

Experimental Question 1

Terminal velocity in a viscous liquid

An object falling in a liquid will eventually reach a constant velocity, called the *terminal velocity*. The aim of this experiment is to measure the terminal velocities of objects falling through glycerine.

For a sphere of radius r falling at velocity v through a viscous liquid, the viscous force F is given by $F = 6\pi\eta rv$. Here η is a property of the liquid called the *viscosity*. In this experiment you will measure the terminal velocity of metal cylinders (because cylinders are easier to make than spheres). The diameter of each cylinder is equal to its length, and we will assume the viscous force on such a cylinder is similar to the viscous force on a sphere of the same diameter, $2r$:

$$F_{cyl} = 6\pi\kappa\eta r^m v \quad (1)$$

where $\kappa = 1$, $m = 1$ for a sphere.

Preliminary

Calculation of terminal velocity (2 marks)

If ρ is the density of the cylinder and ρ' is the density of the liquid, show that the terminal velocity v_T of the cylinder is given by

$$v_T = Cr^{3-m}(\rho - \rho') \quad (2)$$

where C is a constant and derive an expression for C .

Experiment

Use the equipment available to determine the numerical value of the exponent m (10 marks) and the density of glycerine (8 marks).

Notes

- For consistency, try to ensure that the cylinders fall in the same orientation, with the axis of the cylinder horizontal.
- The tolerances on the diameter and the length of the cylinders are 0.05 mm (you need not measure them yourself).
- There is a brass sieve inside the container that you should use to retrieve the metal cylinders. Important: make sure the sieve is in place before dropping objects into the glycerine, otherwise you will not be able to retrieve them for repeat measurements.
- When glycerine absorbs water from the atmosphere, it becomes less viscous. Ensure that the cylinder of glycerine is covered with the plastic film provided when not in use.
- Do not mix cylinders of different size and different material after the experiment.

Material	Density (kgm^{-3})
Aluminium	2.70×10^3
Titanium	4.54×10^3
Stainless steel	7.87×10^3
Copper	8.96×10^3

Experimental Question 2

Diffraction and Scattering of Laser Light

The aim of this experiment is to demonstrate and quantify to some extent the reflection, diffraction, and scattering of light, using visible radiation from a Laser Diode source. A metal ruler is employed as a diffraction grating, and a perspex tank, containing water and diluted milk, is used to determine reflection and scattering phenomena.

Section 1 (6 marks)

Place the 150 mm length metal ruler provided so that it is nearly normal to the incident laser beam, and so that the laser beam illuminates several rulings on it. Observe a number of “spots” of light on the white paper screen provided, caused by the phenomenon of diffraction.

Draw the overall geometry you have employed and measure the position and separation of these spots with the screen at a distance of approximately 1.5 metres from the ruler.

Using the relation

$$N\lambda = h \sin \beta$$

where N is the order of diffraction
 λ is the radiation wavelength
 h is the grating period
 β is the angle of diffraction

and the information obtained from your measurements, determine the wavelength of the laser radiation.

Section 2 (4 marks)

Now insert the empty perspex tank provided into the space between the laser and the white paper screen. Set the tank at approximately normal incidence to the laser beam.

- (i) Observe a reduction in the emergent beam intensity, and estimate the percentage value of this reduction. Some calibrated transmission discs are provided to assist with this estimation. Remember that the human eye has a logarithmic response.

This intensity reduction is caused primarily by reflection losses at the air/perspex boundaries, of which there are four in this case. The reflection coefficient for normal incidence at each boundary, R , which is the ratio of the reflected to incident intensities, is given by

$$R = \{(n_1 - n_2)/(n_1 + n_2)\}^2$$

where n_1 and n_2 are the refractive indices before and after the boundary. The corresponding transmission coefficient, assuming zero absorption in the perspex, is given by

$$T = 1 - R .$$

- (ii) Assuming a refractive index of 1.59 for the perspex and neglecting the effect of multiple reflections and coherence, calculate the intensity transmission coefficient of the empty perspex tank. Compare this result with the estimate you made in Part (i) of this Section.

Section 3 (1 mark)

Without moving the perspex tank, repeat the observations and calculations in Section 2 with the 50 mL of water provided in a beaker now added to the tank. Assume the refractive index of water to be 1.33.

Section 4 (10 marks)

- (i) Add 0.5 mL (12 drops) of milk (the scattering material) to the 50 mL of water in the perspex tank, and stir well. Measure as accurately as possible the total angle through which the laser light is scattered, and the diameter of the emerging light patch at the exit face of the tank, noting that these quantities are related. Also estimate the reduction in transmitted intensity, as in earlier sections.
- (ii) Add a further 0.5 mL of milk to the tank, and repeat the measurements requested in part (i).
- (iii) Repeat the process in part (ii) until very little or no transmitted laser light can be observed.
- (iv) Determine the relationship between scattering angle and milk concentration in the tank.
- (v) Use your results, and the relationship

$$I = I_0 e^{-\mu z} = T_{milk} \times I_0$$

where

I_0	is the input intensity
I	is the emerging intensity
z	is the distance in the tank
μ	is the attenuation coefficient and equals a constant times the concentration of the scatterer
T_{milk}	is the transmission coefficient for the milk

to obtain an estimate for the value of μ for a scatterer concentration of 10%.

Solutions to Theoretical Question 1

Gravitational Red Shift and the Measurement of Stellar Mass

(a)

If a photon has an effective inertial mass m determined by its energy then $mc^2 = hf$ or $m = \frac{hf}{c^2}$. Now, assume that gravitational mass = inertial mass, and consider a photon of energy hf (mass $m = \frac{hf}{c^2}$) emitted upwards at a distance r from the centre of the star. It will lose energy on escape from the gravitational field of the star.

Apply the principle of conservation of energy:

Change in photon energy ($hf_i - hf_f$) = change in gravitational energy, where subscript $i \rightarrow$ initial state and subscript $f \rightarrow$ final state.

$$\begin{aligned} hf_i - hf_f &= -\frac{GMm_f}{\infty} - \left[-\frac{GMm_i}{r} \right] \\ hf_f &= hf_i - \frac{GMm_i}{r} \\ hf_f &= hf_i - \frac{GM \frac{hf_i}{c^2}}{r} \\ hf_f &= hf_i \left[1 - \frac{GM}{rc^2} \right] \\ \frac{f_f}{f_i} &= \left[1 - \frac{GM}{rc^2} \right] \\ \frac{\Delta f}{f} &= \frac{f_f - f_i}{f_i} = -\frac{GM}{rc^2} \end{aligned}$$

The negative sign shows red-shift, i.e. a decrease in f , and an increase in wavelength. Thus, for a photon emitted from the surface of a star of radius R , we have

$$\boxed{\frac{\Delta f}{f} = \frac{GM}{Rc^2}}$$

Since the change in photon energy is small, ($\delta f \ll f$),

$$m_f \simeq m_i = \frac{hf_i}{c^2}.$$

(b)

The change in photon energy in ascending from r_i to r_f is given by

$$\begin{aligned} hf_i - hf_f &= -\frac{GMm_f}{r_f} + \frac{GMm_i}{r_i} \\ &\simeq \frac{GMhf_i}{c^2} \left[\frac{1}{r_i} - \frac{1}{r_f} \right] \\ \therefore \frac{f_f}{f_i} &= 1 - \frac{GM}{c^2} \left[\frac{1}{r_i} - \frac{1}{r_f} \right] \end{aligned}$$

In the experiment, R is the radius of the star, d is the distance from the surface of the star to the spacecraft and the above equation becomes:

$$\frac{f_f}{f_i} = 1 - \frac{GM}{c^2} \left[\frac{1}{R} - \frac{1}{R+d} \right] \quad (1)$$

The frequency of the photon must be doppler shifted back from f_f to f_i in order to cause resonance excitation of the He^+ ions in the spacecraft.

Thus apply the relativistic Doppler principle to obtain:

$$\frac{f'}{f_f} = \sqrt{\frac{1+\beta}{1-\beta}}$$

where f' is the frequency as received by He^+ ions in the spacecraft, and $\beta = v/c$. That is, the gravitationally reduced frequency f_f has been increased to f' because of the velocity of the ions on the spacecraft towards the star. Since $\beta \ll 1$,

$$\frac{f_f}{f'} = (1 - \beta)^{\frac{1}{2}}(1 + \beta)^{-\frac{1}{2}} \simeq 1 - \beta$$

Alternatively, since $\beta \ll 1$, use the classical Doppler effect directly. Thus

$$f' = \frac{f_f}{1 - \beta}$$

or

$$\frac{f_f}{f'} = 1 - \beta$$

Since f' must be equal to f_i for resonance absorption, we have

$$\frac{f_f}{f_i} = 1 - \beta \quad (2)$$

Substitution of 2 into 1 gives

$$\beta = \frac{GM}{c^2} \left(\frac{1}{R} - \frac{1}{R+d} \right) \quad (3)$$

Given the experimental data, we look for an effective graphical solution. That is, we require a linear equation linking the experimental data in β and d .

Rewrite equation 3:

$$\beta = \frac{GM}{c^2} \left[\frac{R+d-R}{(R+d)R} \right]$$

Inverting the equation gives:

$$\frac{1}{\beta} = \left(\frac{Rc^2}{GM} \right) \left[\frac{R}{d} + 1 \right]$$

or

$$\boxed{\frac{1}{\beta} = \left(\frac{R^2c^2}{GM} \right) \frac{1}{d} + \frac{Rc^2}{GM}}$$

Graph of $\frac{1}{\beta}$ vs. $\frac{1}{d}$

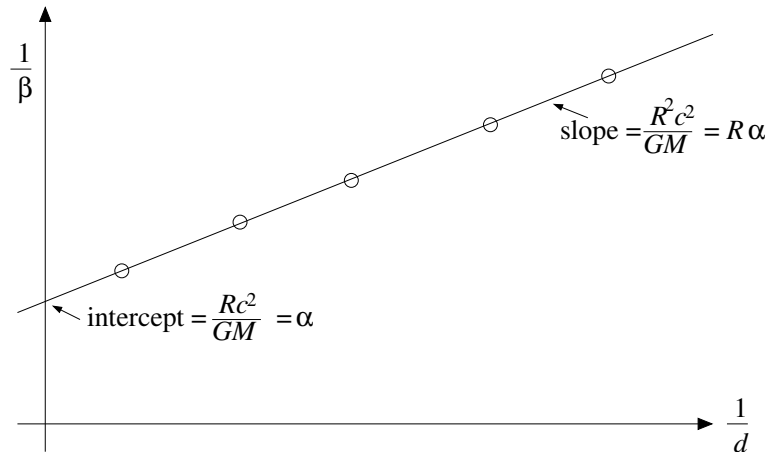

$$\text{The slope is } \left(\frac{Rc^2}{GM} \right) R = \alpha R \quad (A)$$

$$\text{The } \frac{1}{\beta}\text{-intercept is } \left(\frac{Rc^2}{GM} \right) = \alpha \quad (B)$$

$$\text{and the } \frac{1}{d}\text{-intercept is } -\frac{1}{R} \quad (C)$$

R and M can be conveniently determined from (A) and (B). Equation (C) is redundant. However, it may be used as an (inaccurate) check if needed.

From the given data:

$$R = 1.11 \times 10^8 \text{ m}$$

$$M = 5.2 \times 10^{30} \text{ kg}$$

From the graph, the slope $\alpha R = 3.2 \times 10^{12} \text{ m}$ (A)

The $\frac{1}{\beta}$ -intercept $\alpha = \frac{Rc^2}{GM} = 0.29 \times 10^5$ (B)

Dividing (A) by (B)

$$R = \frac{3.2 \times 10^{12} \text{ m}}{0.29 \times 10^5} \simeq \boxed{1.104 \times 10^8 \text{ m}}$$

Substituting this value of R back into (B) gives:

$$M = \frac{Rc^2}{g\alpha} = \frac{(1.104 \times 10^8) \times (3.0 \times 10^8)^2}{(6.7 \times 10^{-11}) \times (0.29 \times 10^5)}$$

or $M = 5.11 \times 10^{30} \text{ kg}$

(c)

(i)

Atom before the decay Atom and photon after the decay

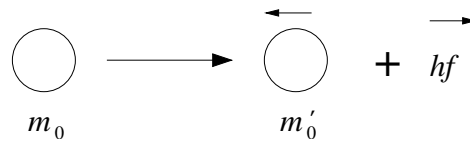

For the photon, photon momentum is $p = \frac{hf}{c}$ and photon energy is $E = hf$.

Use the mass-energy equivalence, $E = mc^2$, to relate the internal energy change of the atom to the rest-mass change. Thus:

$$\Delta E = (m_0 - m'_0) c^2 \quad (1)$$

In the laboratory frame of reference the energy before emission is

$$E = m_0 c^2 \quad (2)$$

Recalling the relativistic relation

$$E^2 = p^2 c^2 + m_0^2 c^4$$

The energy after emission of a photon is

$$E = \sqrt{p^2 c^2 + m_0'^2 c^4} + hf \quad (3)$$

where also $p = hf/c$ by conservation of momentum.

Conservation of energy requires that (2) = (3), so that:

$$(m_0 c^2 - hf)^2 = (hf)^2 + m_0'^2 c^4$$

$$(m_0 c^2)^2 - 2hf m_0 c^2 = m_0'^2 c^4$$

Carrying out the algebra and using equation (1):

$$\begin{aligned} hf(2m_0 c^2) &= (m_0^2 - m_0'^2) c^4 \\ &= (m_0 - m_0') c^2 (m_0 + m_0') c^2 \\ &= \Delta E [2m_0 - (m_0 - m_0')] c^2 \\ &= \Delta E [2m_0 c^2 - \Delta E] \end{aligned}$$

$$hf = \Delta E \left[1 - \frac{\Delta E}{2m_0c^2} \right]$$

(ii)

For the emitted photon,

$$hf = \Delta E \left[1 - \frac{\Delta E}{2m_0c^2} \right] .$$

If relativistic effects are ignored, then

$$hf_0 = \Delta E .$$

Hence the relativistic frequency shift $\frac{\Delta f}{f_0}$ is given by

$$\frac{\Delta f}{f_0} = \frac{\Delta E}{2m_0c^2}$$

For He^+ transition ($n = 2 \rightarrow 1$), applying Bohr theory to the hydrogen-like helium ion gives:

$$\Delta E = 13.6 \times 2^2 \times \left[\frac{1}{1^2} - \frac{1}{2^2} \right] = 40.8 \text{ eV}$$

Also, $m_0c^2 = 3.752 \times 10^6 \text{ eV}$. Therefore the frequency shift due to the recoil gives

$$\frac{\Delta f}{f_0} \simeq 5.44 \times 10^{-12}$$

This is very small compared to the gravitational red-shift of $\frac{\Delta f}{f} \sim 10^{-5}$, and may be ignored in the gravitational red-shift experiment.

Solutions to Theoretical Question 2

(a)

Snell's Law may be expressed as

$$\frac{\sin \theta}{\sin \theta_0} = \frac{c}{c_0} \quad , \quad (1)$$

where c is the speed of sound.

Consider some element of ray path ds and treat this as, locally, an arc of a circle of radius R . Note that R may take up any value between 0 and ∞ . Consider a ray component which is initially directed upward from S .

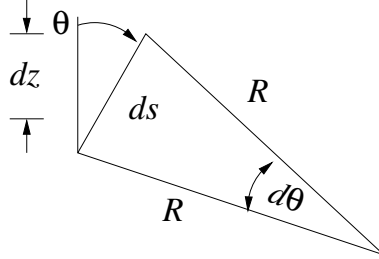

In the diagram, $ds = R d\theta$, or $\frac{ds}{d\theta} = R$.

From equation (1), for a small change in speed dc ,

$$\cos \theta d\theta = \frac{\sin \theta_0}{c_0} dc$$

For the upwardly directed ray $c = c_0 + bz$ so $dc = b dz$ and

$$\frac{\sin \theta_0}{c_0} b dz = \cos \theta d\theta \quad , \quad \text{hence} \quad dz = \frac{c_0}{\sin \theta_0} \frac{1}{b} \cos \theta d\theta \quad .$$

We may also write (here treating ds as straight) $dz = ds \cos \theta$. So

$$ds = \frac{c_0}{\sin \theta_0} \frac{1}{b} d\theta$$

Hence

$$\frac{ds}{d\theta} = R = \frac{c_0}{\sin \theta_0} \frac{1}{b} \quad .$$

This result strictly applies to the small arc segments ds . Note that from equation (1), however, it also applies for all θ , i.e. for all points along the trajectory, which therefore forms an arc of a circle with radius R until the ray enters the region $z < 0$.

(b)

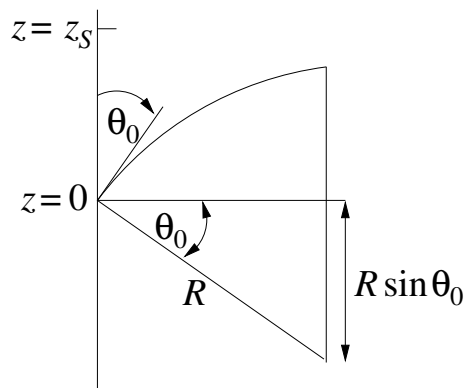

Here

$$\begin{aligned} z_s &= R - R \sin \theta_0 \\ &= R(1 - \sin \theta_0) \\ &= \frac{c_0}{b \sin \theta_0} (1 - \sin \theta_0) , \end{aligned}$$

from which

$$\theta_0 = \sin^{-1} \left[\frac{c_0}{bz_s + c_0} \right] .$$

(c)

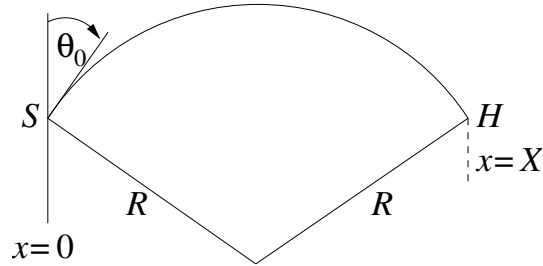

The simplest pathway between S and H is a single arc of a circle passing through S and H . For this pathway:

$$X = 2R \cos \theta_0 = \frac{2c_0 \cos \theta_0}{b \sin \theta_0} = \frac{2c_0}{b} \cot \theta_0 .$$

Hence

$$\cot \theta_0 = \frac{bX}{2c_0} .$$

The next possibility consists of two circular arcs linked as shown.

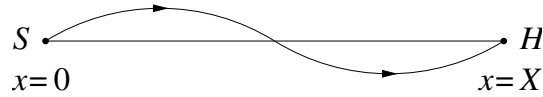

For this pathway:

$$\frac{X}{2} = 2R \cos \theta_0 = \frac{2c_0}{b} \cot \theta_0 .$$

i.e.

$$\cot \theta_0 = \frac{bX}{4c_0} .$$

In general, for values of $\theta_0 < \frac{\pi}{2}$, rays emerging from S will reach H in n arcs for launch angles given by

$$\theta_0 = \cot^{-1} \left[\frac{bX}{2nc_0} \right] = \tan^{-1} \left[\frac{2nc_0}{bX} \right]$$

where $n = 1, 2, 3, 4, \dots$

Note that when $n = \infty$, $\theta_0 = \frac{\pi}{2}$ as expected for the axial ray.

(d)

With the values cited, the four smallest values of launch angle are

n	θ_0 (degrees)
1	86.19
2	88.09
3	88.73
4	89.04

(e)

The ray path associated with the smallest launch angle consists of a single arc as shown:

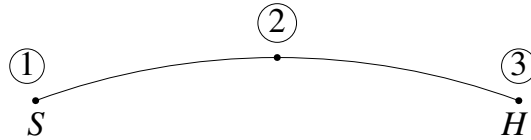

We seek

$$\int_1^3 dt = \int_1^3 \frac{ds}{c}$$

Try first:

$$t_{12} = \int_1^2 \frac{ds}{c} = \int_{\theta_0}^{\pi/2} \frac{Rd\theta}{c}$$

Using

$$R = \frac{c}{b \sin \theta}$$

gives

$$t_{12} = \frac{1}{b} \int_{\theta_0}^{\pi/2} \frac{d\theta}{\sin \theta}$$

so that

$$t_{12} = \frac{1}{b} \left[\ln \tan \frac{\theta}{2} \right]_{\theta_0}^{\pi/2} = -\frac{1}{b} \ln \tan \frac{\theta_0}{2}$$

Noting that $t_{13} = 2t_{12}$ gives

$$t_{13} = -\frac{2}{b} \ln \tan \frac{\theta_0}{2} .$$

For the specified b , this gives a transit time for the smallest value of launch angle cited in the answer to part (d), of

$$t_{13} = 6.6546 \text{ s}$$

The axial ray will have travel time given by

$$t = \frac{X}{c_0}$$

For the conditions given,

$$t_{13} = 6.6666 \text{ s}$$

thus this axial ray travels slower than the example cited for $n = 1$, thus the $n = 1$ ray will arrive first.

Solutions to Theoretical Question 3

(a)

The mass of the rod is given equal to the mass of the cylinder M which itself is $\pi a^2 l d$. Thus the total mass equals $2M = 2\pi a^2 l d$. The mass of the displaced water is surely less than $\pi a^2 l \rho$ (when the buoy is on the verge of sinking). Using Archimedes' principle, we may at the very least expect that

$$2\pi a^2 l d < \pi a^2 l \rho \quad \text{or} \quad d < \rho/2$$

In fact, with the floating angle $\alpha (< \pi)$ as drawn, the volume of displaced water is obtained by geometry:

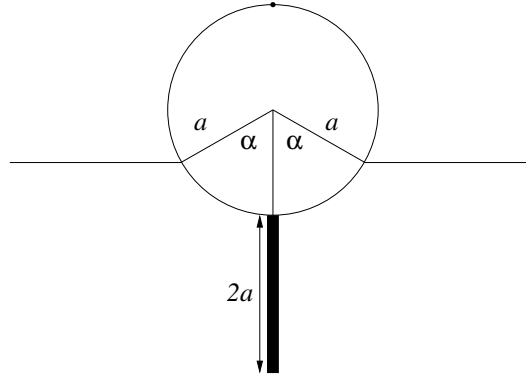

$$V = la^2 \alpha - la^2 \sin \alpha \cos \alpha .$$

By Archimedes' principle, the mass of the buoy equals the mass of displaced water. Therefore, $2\pi a^2 l d = la^2 \rho (\alpha - \sin \alpha \cos \alpha)$, i.e. α is determined by the relation

$$\alpha - \sin \alpha \cos \alpha = 2d\pi/\rho .$$

(b)

If the cylinder is depressed a *small* distance z vertically from equilibrium, the nett upward restoring force is the weight of the extra water displaced or $g\rho \cdot 2a \sin \alpha \cdot lz$, directed oppositely to z . This is characteristic of simple harmonic motion and hence the Newtonian equation of motion of the buoy is (upon taking account of the extra factor $1/3$)

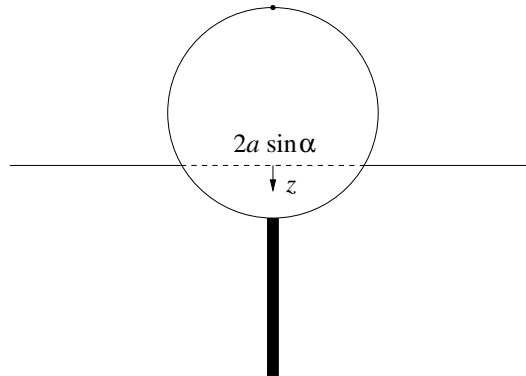

$$8M\ddot{z}/3 = -2\rho g l z a \sin \alpha \quad \text{or} \quad \ddot{z} + \frac{3\rho g \sin \alpha}{4\pi d a} z = 0 ,$$

and this is the standard sinusoidal oscillator equation (like a simple pendulum). The solution is of the type $z = \sin(\omega_z t)$, with the angular frequency

$$\omega_z = \sqrt{\frac{3\rho g \sin \alpha}{4\pi d a}} = \sqrt{\frac{3g \sin \alpha}{2a(\alpha - \cos \alpha \sin \alpha)}} ,$$

where we have used the relation worked out at the end of the first part.

(c)

Without regard to the torque and only paying heed to vertical forces, if the buoy is swung by some angle so that its weight is supported by the nett pressure of the water outside, the volume of water displaced is the same as in equilibrium. Thus the centre of buoyancy remains at the same distance from the centre of the cylinder. Consequently we deduce that the buoyancy arc is an arc of a circle centred at the middle of the cylinder. In other words, *the metacentre M of the swinging motion is just the centre of the cylinder*. In fact the question assumes this.

We should also notice that the centre of mass G of the buoy is at the point where the rod touches the cylinder, since the masses of rod and cylinder each equal M . Of course the cylinder will experience a nett torque when the rod is inclined to the vertical. To find the period of swing, we first need to determine the moment of inertia of the solid cylinder about the central axis; this is just like a disc about the centre. Thus if M is the cylinder mass

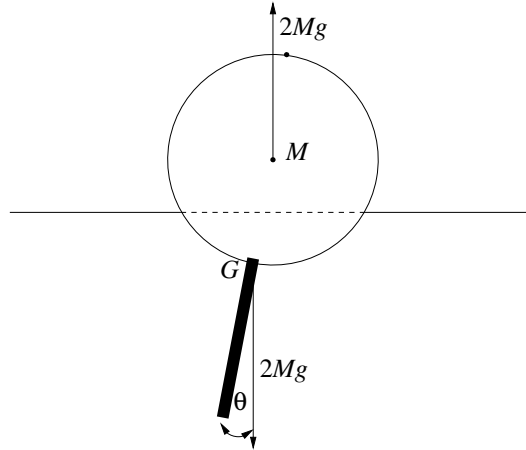

$$I_0 = Ma^2/2 \left(= \int_0^a r^2 dm = \int_0^a r^2 \cdot 2Mr dr/a \right)$$

The next step is to find the moment of inertia of the rod about its middle,

$$I_{rod} = \int_{-a}^a (Mdx/2a) \cdot x^2 = [Mx^3/6a]_{-a}^a = Ma^2/3 .$$

Finally, use the parallel axis theorem to find the moment of inertia of the buoy (cylinder + rod) about the metacentre M ,

$$I_M = Ma^2/2 + [Ma^2/3 + M(2a)^2] = 29Ma^2/6 .$$

(In this part we are neglecting the small horizontal motion of the centre of mass; the water is the only agent which can supply this force!) When the buoy swings by an angle θ about equilibrium the restoring torque is $2Mga \sin \theta \simeq 2Mga\theta$ for small angles, which represents simple harmonic motion (like simple pendulum). Therefore the Newtonian rotational equation of motion is

$$I_M \ddot{\theta} \simeq -2Mga\theta , \quad \text{or} \quad \ddot{\theta} + \frac{12g}{29a} = 0 .$$

The solution is a sinusoidal function, $\theta \propto \sin(\omega_\theta t)$, with angular frequency

$$\omega_\theta = \sqrt{12g/29a} .$$

(d)

The accelerometer measurements give

$$T_\theta/T_z \simeq 1.5 \quad \text{or} \quad (\omega_z/\omega_\theta)^2 \simeq 9/4 \simeq 2.25 . \quad \text{Hence}$$

$$2.25 = \frac{3g \sin \alpha}{2a(\alpha - \sin \alpha \cos \alpha)} \frac{29a}{12g} ,$$

producing the (transcendental) equation

$$\alpha - \sin \alpha \cos \alpha \simeq 1.61 \sin \alpha .$$

Since 1.61 is not far from 1.57 we have discovered that a physically acceptable solution is $\alpha \simeq \pi/2$, which was to be shown. (In fact a more accurate solution to the above transcendental equation can be found numerically to be $\alpha = 1.591$.) Setting *alpha* = $\pi/2$ hereafter, to simplify the algebra, $\omega_z^2 = 3g/\pi a$ and $4d/\rho = 1$ to a good approximation. Since the vertical period is 1.0 sec,

$$1.0 = (2\pi/\omega_z)^2 = 4\pi^3 a/3g ,$$

giving the radius $a = 3 \times 9.8/4\pi^3 = .237$ m.

We can now work out the mass of the buoy (in SI units),

$$2M = 2\pi a^2 l d = 2\pi a^2 a \cdot \rho/4 = \pi a^3 \rho/2 = \pi \times 500 \times (.237)^3 \simeq 20.9 \text{ kg} .$$

Solutions to Original Theoretical Question 3

(a)

Choose a frame where z is along the normal to the mirror and the light rays define the x - z plane. For convenience, recording the energy-momentum in the four-vector form, $(p_x, p_y, p_z, E/c)$, the initial photon has

$$P_i = (p \sin \theta_i, 0, p \cos \theta_i, p)$$

where $p = E_i/c = hf_i/c$.

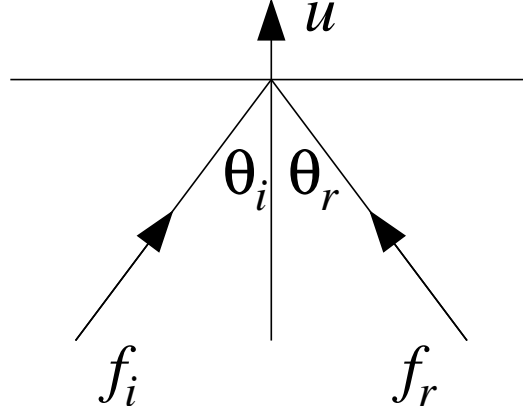

By the given Lorentz transformation rules, in the moving mirror frame the energy-momentum of the incident photon reads

$$P_{\text{mirror}} = \left(p \sin \theta_i, 0, \frac{p \cos \theta_i - up/c}{\sqrt{1 - u^2/c^2}}, \frac{p - up \cos \theta_i/c}{\sqrt{1 - u^2/c^2}} \right).$$

Assuming the collision is elastic in that frame, the reflected photon has energy-momentum,

$$P'_{\text{mirror}} = \left(p \sin \theta_i, 0, \frac{-p \cos \theta_i + up/c}{\sqrt{1 - u^2/c^2}}, \frac{p - up \cos \theta_i/c}{\sqrt{1 - u^2/c^2}} \right).$$

Transforming back to the original frame, we find that the reflected photon has

$$\begin{aligned} p_{xr} &= p \sin \theta_i, & p_{yr} &= 0 \\ p_{zr} &= \frac{(-p \cos \theta_i + up/c) + u(p - up \cos \theta_i/c)/c}{1 - u^2/c^2} \\ E_r/c &= \frac{(p - up \cos \theta_i/c) + u(-p \cos \theta_i + up/c)/c}{1 - u^2/c^2} \end{aligned}$$

Simplifying these expressions, the energy-momentum of the reflected photon in the original frame is

$$P_r = \left(p \sin \theta_i, 0, \frac{p(-\cos \theta_i + 2u/c - u^2 \cos \theta_i/c^2)}{1 - u^2/c^2}, \frac{p(1 - 2u \cos \theta_i/c + u^2/c^2)}{1 - u^2/c^2} \right).$$

Hence the angle of reflection θ_r is given by

$$\tan \theta_r = -\frac{p_{xr}}{p_{zr}} = \frac{\sin \theta_i(1 - u^2/c^2)}{\cos \theta_i - 2u/c + u^2 \cos \theta_i/c^2} = \frac{\tan \theta_i(1 - u^2/c^2)}{1 + u^2/c^2 - 2u \sec \theta_i/c^2},$$

while the ratio of reflected frequency f_r to incident frequency f_i is simply the energy ratio,

$$\frac{f_r}{f_i} = \frac{E_r}{E_i} = \frac{1 - 2u \cos \theta_i/c + u^2/c^2}{1 - u^2/c^2}.$$

[For future use we may record the changes to first order in u/c :

$$\begin{aligned} \tan \theta_r &\simeq \tan \theta_i(1 + 2u \sec \theta_i/c) \quad \text{so} \\ \tan(\theta_r - \theta_i) &= \frac{\tan \theta_r - \tan \theta_i}{1 + \tan \theta_r \tan \theta_i} \simeq \frac{2u \tan \theta_i \sec \theta_i/c}{1 + \tan^2 \theta_i} \simeq \frac{2u \sin \theta_i}{c} \end{aligned}$$

Thus, $\theta_r \simeq \theta_i + 2u \sin \theta_i/c$ and $f_r = f_i(1 - 2u \cos \theta_i/c)$.]

(b)

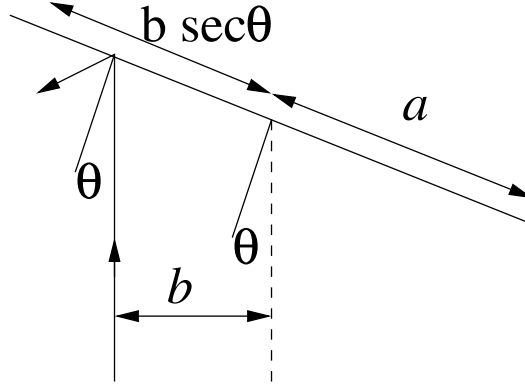

Hereafter define $\theta_i = \theta$. Provided that $b/\cos\theta < a$ the laser light will reflect off the mirror, so $\cos\theta > b/a$ is needed for photon energy-momentum to be imparted to the mirror. Let us then define a critical angle α via $\cos\alpha = b/a$.

The change in the normal component Δp_{\parallel} of the momentum of a single photon is

$$\Delta L = \frac{\Delta p_{\parallel} b}{\cos\theta} = \frac{b}{\cos\theta} \left[p \cos\theta - \frac{p(-\cos\theta + 2u/c - u^2 \cos\theta/c^2)}{1 + u^2/c^2} \right] ,$$

$$\Delta L = \frac{bp(2\cos\theta - 2u/c)}{\cos\theta(1 + u^2/c^2)} = \frac{2bp(1 - u \sec\theta/c)}{(1 + u^2/c^2)} \simeq 2bp(1 - u \sec\theta/c) .$$

Since $u \cos\theta = \omega b$, $\Delta L \simeq 2bp(1 - \omega b \sec^2\theta/c)$ per photon. Suppose N photons strike every second (and $|\theta|$ is less than the critical angle α). Then in time dt we have Ndt photons. But $dt = d\theta/\omega$, so in this time we have,

$$dL = N \frac{d\theta}{\omega} \times 2bp \left(\frac{\omega b}{c} \sec^2\theta \right)$$

Thus the change in ΔL per revolution is

$$\frac{dL}{dn} = 2 \times \frac{2bpN}{\omega} \int_{-\alpha}^{\alpha} (1 - \omega b \sec^2\theta/c) d\theta$$

where n refers to the number of revolutions. So

$$\frac{dL}{dn} \simeq \frac{8bpN}{\omega} \left(\alpha - \frac{\omega b}{c} \tan\alpha \right) = \frac{8bP}{\omega c} \left(\alpha - \frac{\omega b}{c} \tan\alpha \right) ,$$

since each photon has energy pc and laser power equals $P = Npc$.

Clearly $\omega b \ll c$ always, so $dL/dn \simeq 8bP\alpha/\omega c$; thus

$$\frac{dL}{dt} = \frac{dL}{dn} \frac{dn}{dt} = \frac{\omega}{2\pi} \frac{dL}{dn} = \frac{4bP\alpha}{\pi c} .$$

(c)

Therefore if I is the moment of inertia of the mirror about its axis of rotation,

$$I \frac{d\omega}{dt} \simeq \frac{4bP\alpha}{\pi c} , \text{ or } \omega(t) \simeq \frac{4bP\alpha t}{\pi c I} .$$

[Some students may derive the rate of change of angular velocity using energy conservation, rather than considering the increase of angular momentum of the mirror: To first order in v/c , $E_r = E(1 - 2u \cos\theta/c)$, therefore the energy imparted to the mirror is

$$\Delta E = E - E_r \simeq \frac{2uE \cos\theta}{c} = \frac{2\omega b E}{c}$$

In one revolution, the number of photons intersected is

$$\frac{4\alpha}{2\pi} \times n \frac{2\pi}{\omega} = \frac{4\alpha n}{\omega} .$$

Therefore the rate of increase of rotational energy ($E_{\text{rot}} = I\omega^2/2$) is

$$\frac{dE_{\text{rot}}}{dt} = \frac{4\alpha N}{\omega} \frac{2\omega b E}{c} \frac{dn}{dt} = \frac{8\alpha b P}{c} \frac{\omega}{2\pi} = \frac{4\alpha b P \omega}{\pi c}$$

Thus $I\omega \cdot d\omega/dt = 4\alpha b P/\pi c$, leading to $\omega(t) \simeq 4\alpha b P t/\pi c I$, again.]

(d)

To estimate the deflection of the beam, one first needs to work out the moment of inertia of a rectangle of mass m and side $2a$ about the central axis. This is just like a rod. From basic principles,

$$I = \int_{-a}^a \frac{m dx}{2a} x^2 = \left[\frac{m x^3}{6a} \right]_{-a}^a = \frac{m a^2}{3} = \frac{m b^2 \sec^2 \alpha}{3} .$$

With the stated geometry, $a = b\sqrt{2}$, or $\alpha = 45^\circ$, so

$$\omega \simeq \frac{12\alpha P t \cos^2 \alpha}{\pi m c b} \rightarrow \frac{3 P t}{m c a \sqrt{2}} .$$

At the edge, $u = \omega a = 3 P t / m c \sqrt{2}$, and the angle of deviation is

$$\delta = \frac{2u \sin \alpha}{c} = \frac{3 P t}{m c^2}$$

[Interestingly, it is determined by the ratio of the energy produced by the laser to the rest-mass energy of the mirror.]

Using the given numbers, and in SI units, the deviation is

$$\xi \simeq 10^4 \delta = \frac{10^4 \times 3 \times 100 \times 24 \times 3600}{10^{-3} \times (3 \times 10^8)^2} \simeq 2.9 \text{ mm} .$$

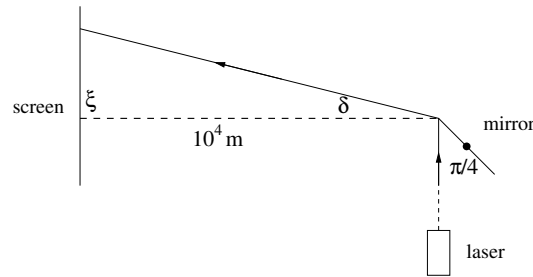

Solution to Experimental Question 1

Preliminary: Calculation of Terminal Velocity

When the cylinder is moving at its terminal velocity, the resultant of the three forces acting on the cylinder, gravity, viscous drag and buoyant force, is zero.

$$V\rho g - 6\pi\kappa\eta r^m v_T - V\rho'g = 0$$

where $V = 2\pi r^3$ is the volume of a cylinder (whose height is $2r$).

This gives

$$v_r = Cr^{3-m}(\rho - \rho')$$

where

$$C = \frac{g}{3\kappa\eta}$$

Experiment

Determination of the exponent m

Aluminium cylinders of different diameters are dropped into the glycerine. Fall times between specified marks on the measuring cylinder containing the glycerine are recorded for each cylinder. A preliminary experiment should establish that the cylinders have reached their terminal velocity before detailed results are obtained. The measurements are repeated several times for each cylinder and an average fall time is calculated. Table 1 shows a typical set of data. To find the value of m a graph of $\log(\text{fall time})$ as a function of $\log(\text{diameter})$ is plotted as in figure 1. The slope of the resulting straight line graph is $3 - m$ from which a value of m can be determined. A reasonable value for m is 1.33 with an uncertainty of order ± 0.1 . The uncertainty is estimated by the deviation from the line of best fit through the data points obtained by drawing other possible lines.

Determination of the density of glycerine

Cylinders with the same geometry but different densities are dropped into the glycerine and timed as in the first part of the experiment. Table 2 shows a typical set of results. From equation (2) a linear plot of $1/t$ as a function of density should yield a straight line with an intercept on the density axis corresponding to the density of glycerine. Figure 2 shows a typical plot. Alternatively the terminal velocities could be calculated and plotted against density which would again lead to the same intercept on the density axis. The uncertainty in the measurement can be estimated by drawing other possible straight lines through the data points and noting the change in the value of the intercept.

Diameter (mm)	Individual readings (s)						Mean (s)
10	1.44	1.56	1.44	1.37	1.44	1.41	1.44
4	6.22	6.06	6.16	6.13	6.13	6.22	6.15
8	1.80	1.82	1.78	1.84	1.82	1.81	1.82
5	4.06	4.34	4.09	4.12	4.25	4.13	4.13

Table 1: Sample data set

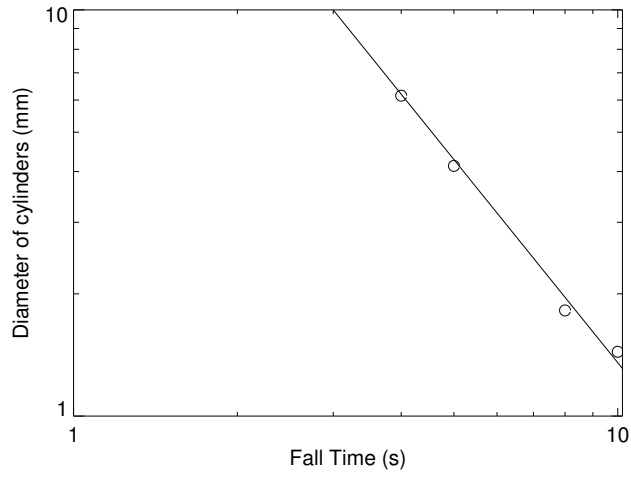

Figure 1: Sample plot

$$\text{Slope} = -\frac{58.2}{66.2} \div \frac{48.5}{93} = -1.67 \quad \therefore m = 3 - 1.67 = 1.33$$

Material	Individual readings (s)						Mean (s)
Ti	3.00	2.91	2.97	2.91	2.84	2.75	2.91
Cu	1.25	1.25	1.28	1.25	1.22	1.22	1.25
S.Steel	1.31	1.32	1.38	1.44	1.31	1.34	1.33
Al	6.03	6.09	6.09	6.16	6.06	6.06	6.08

Table 2: Sample data set

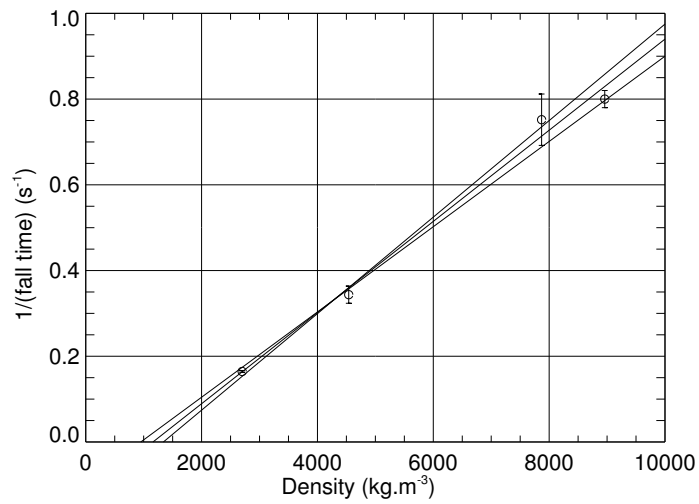

Figure 2: Sample plot

$$\rho' = (1.1 \pm 0.2) \times 10^3 \text{ kg.m}^{-3}$$

Detailed mark allocation

Section 1

Reasonable range of data points with a scatter of ~ 0.1 s	[2]
Check that the cylinders have reached their terminal velocity	
Visual check, or check referred to	[1]
Specific data presented	[1]
Labelled log-log graph	[2]
Data points for all samples, with a reasonable scatter about a straight line on the log-log graph	[1]
Calculation of $(3 - m)$ from graph	[1]
including estimate of error in determining m	[1]
Reasonable value of m , ~ 1.33	[1]
Subtotal	[10]

Section 2

Reasonable range of data points	[1]
Check that the cylinders have reached their terminal velocity	[1]
Labelled graph of $(\text{falltime})^{-1}$ vs. density of cylinder	[1]
Data points for all samples, with a reasonable scatter about a straight line on the $(\text{falltime})^{-1}$ vs. density of cylinder graph	[1]
Calculation of the density of glycerine (ρ') from this graph	[1]
Estimate of uncertainty in ρ'	[1]
Reasonable value of ρ' . "Correct" value is 1.260 kg.m^{-3}	[1]
Subtotal	[8]
TOTAL	20

Solution to Experimental Question 2

Section 1

- i. A typical geometric layout is as shown below.
 - (a) Maximum distance from ruler to screen is advised to increase the spread of the diffraction pattern.
 - (b) Note that the grating (ruler) lines are horizontal, so that diffraction is in the vertical direction.

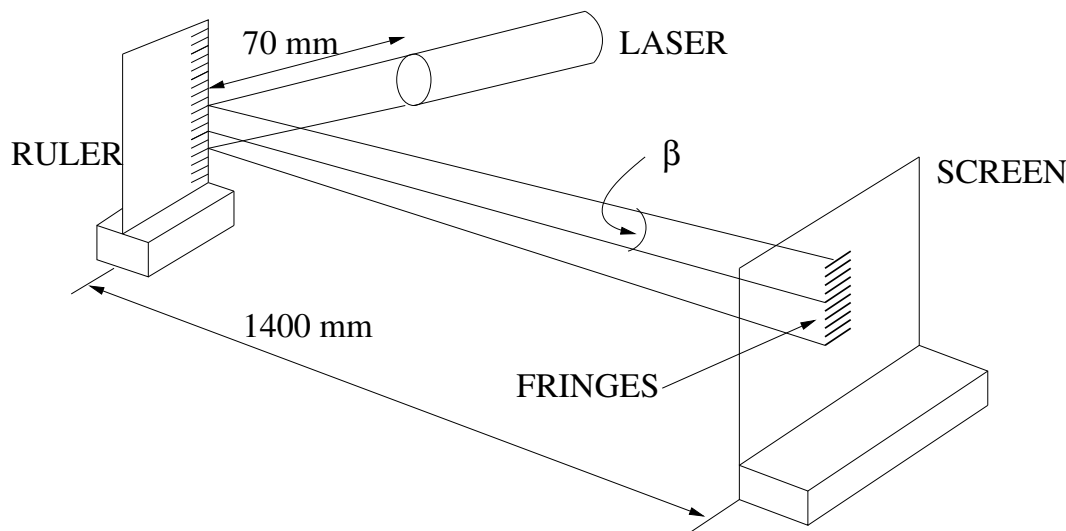

- ii. Vis a vis the diffraction phenomenon, $\beta = \left(\frac{y}{1400 \text{ mm}}\right)$

The angle β is measured using either a protractor (not recommended) or by measuring the value of the fringe separation on the screen, y , for a given order N .

If the separation between 20 orders is measured, then $N = \pm 10$ ($N = 0$ is central zero order).

The values of y should be tabulated for $N = 10$. If students choose other orders, this is also acceptable.

N	± 10	± 10	± 10	± 10	± 10	± 10	± 10	± 10	± 10	± 10
$2y$ mm	39.0	38.5	39.5	41.0	37.5	38.0	39.0	38.0	37.0	37.5
y mm	19.5	19.25	19.75	20.5	18.75	19.0	19.5	19.0	18.5	18.75

Mean Value = (19.25 ± 1.25) mm

i.e. Mean “spot” distance = 19.25 mm for order $N = 10$.

From observation of the ruler itself, the grating period, $h = (0.50 \pm 0.02)$ mm.

Thus in the relation

$$\begin{aligned}
 N\lambda &= \pm h \sin \beta \\
 N &= 10 \\
 h &= 0.5 \text{ mm} \\
 \sin \beta \simeq \beta &= \frac{y}{1400 \text{ mm}} = 0.01375 \\
 10\lambda &= 0.006875 \text{ mm} \\
 \lambda &= 0.0006875 \text{ mm}
 \end{aligned}$$

Since β is small, $\frac{\delta\lambda}{\lambda} \simeq \frac{\delta h}{h} + \frac{\delta y}{y} \simeq 10\%$

i.e. measured $\lambda = (690 \pm 70)$ nm

The accepted value is 680 nm so that the departure from accepted value equals 1.5%.

Section 2

This section tests the student's ability to make semi-quantitative measurements and the use of judgement in making observations.

- i. Using the $T = 50\%$ transmission disc, students should note that the transmission through the tank is greater than this value. Using a linear approximation, 75% could well be estimated. Using the hint about the eye's logarithmic response, the transmission through the tank could be estimated to be as high as 85%.

Any figure for transmission between 75% and 85% is acceptable.

- ii. Calculation of the transmission through the tank, using

$$T = 1 - R = 1 - \left(\frac{n_1 - n_2}{n_1 + n_2} \right)^2$$

for each of the four surfaces of the tank, and assuming $n = 1.59$ for the perspex, results in a total transmission

$$T_{\text{total}} = 80.80\%$$

Section 3

With water in the tank, surfaces 2 and 3 become perspex/water interfaces instead of perspex/air interfaces, as in (ii).

The resultant value is

$$T_{\text{total}} = 88.5\%$$

Section 4

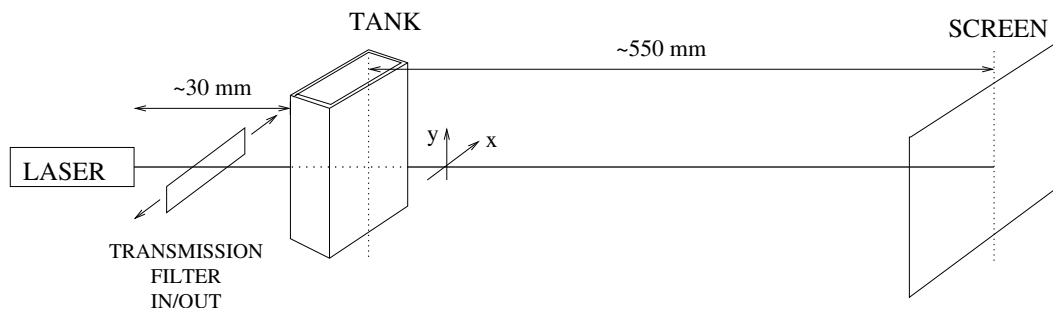

Possible configuration for section 4 (and sections 2 and 3)

With pure water in the tank only, we see from Section 3 that the transmission T is

$$T_{\text{Water}} \simeq 88\%$$

The aim here is to determine the beam divergence (scatter) and transmission as a function of milk concentration. Looking down on the tank, one sees

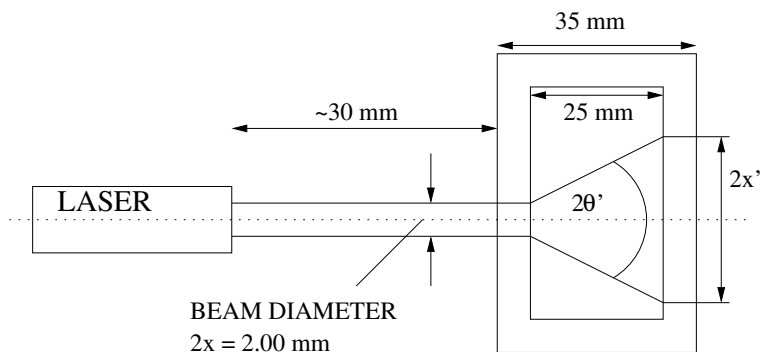

- i. The entrance beam diameter is 2.00 mm. The following is an example of the calculations expected:
With 0.5 mL milk added to the 50 mL water, we find

$$\text{Scatterer concentration} = \frac{0.5}{50} = 1\% = 0.01$$

Scattering angle

$$2x' = 2.2 \text{ mm} \quad ; \quad 2\theta' = \frac{2x'}{30} = 0.073$$

Transmission estimated with the assistance of the neutral density filters

$$T_{\text{total}} = 0.7 \quad .$$

Hence

$$T_{\text{milk}} = \frac{0.7}{0.88} = 0.79$$

Note that

$$T_{\text{milk}} = \frac{T_{\text{total}}}{T_{\text{water}}} \quad \text{and} \quad T_{\text{water}} = 0.88 \quad (1)$$

If students miss the relationship (1), deduct one mark.

- ii. & iii. One thus obtains the following table of results. $2\theta'$ can be determined as shown above, OR by looking down onto the tank and using the protractor to measure the value of $2\theta'$. It is important to note that even in the presence of scattering, there is still a direct beam being transmitted. It is much stronger than the scattered radiation intensity, and some skill will be required in measuring the scattering angle $2\theta'$ using either method. Making the correct observations requires observational judgement on the part of the student.

Typical results are as follows:

Milk volume (mL)	0	0.5	1.0	1.5	2.0	2.5	3.0	3.5	4.0
% Concentration	0	1	2	3	4	5	6	7	8
$2x'$	2.00	2.2	6.2	9.4	12	Protractor			
$2\theta'$ (Degrees)	~ 0	4	12	18	23	28	36	41	48
T_{milk}	1.0	0.79	0.45	0.22	0.15	0.12	0.08	0.06	0.05

- iii. From the graphed results in Figure 1, one obtains an approximately linear relationship between milk concentration, C , and scattering angle, $2\theta'$ ($= \phi$) of the form

$$\phi = 6C \quad .$$

- iv. Assuming the given relation

$$I = I_0 e^{-\mu z} = T_{\text{milk}} I_0$$

where z is the distance into the tank containing milk/water.

We have

$$T_{\text{milk}} = e^{-\mu z}$$

Thus

$$\ln T_{\text{milk}} = -\mu z \quad , \text{ and } \mu = \text{constant} \times C$$

Hence $\ln T_{\text{milk}} = -\alpha z C$.

Since z is a constant in this experiment, a plot of $\ln T_{\text{milk}}$ as a function of C should yield a straight line. Typical data for such a plot are as follows:

% Concentration	0	1	2	3	4	5	6	7	8
T_{milk}	1.0	0.79	0.45	0.22	0.15	0.12	0.08	0.06	0.05
$\ln T_{\text{milk}}$	0	-0.24	-0.8	-1.51	-1.90	-2.12	-2.53	-2.81	-3.00

An approximately linear relationship is obtained, as shown in Figure 2, between $\ln T_{\text{milk}}$ and C , the concentration viz.

$$\ln T_{\text{milk}} \simeq -0.4C = -\mu z$$

Thus we can write

$$T_{\text{milk}} = e^{-0.4C} = e^{-\mu z}$$

For the tank used, $z = 25$ mm and thus

$$0.4C = 25\mu \quad \text{or} \quad \mu = 0.016C \quad \text{whence} \quad \alpha = 0.016 \text{ mm}^{-1}\%^{-1}$$

By extrapolation of the graph of $\ln T_{\text{milk}}$ versus concentration C , one finds that for a scatterer concentration of 10%

$$\mu = 0.160 \text{ mm}^{-1} \quad .$$

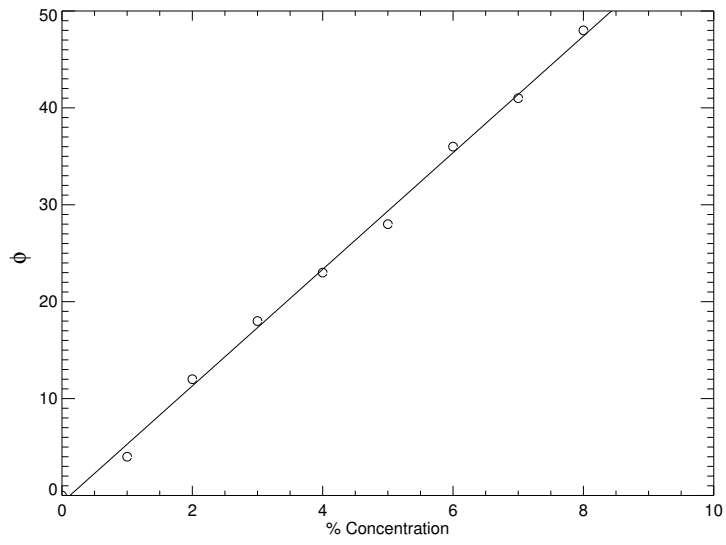

Figure 1: Sample plot

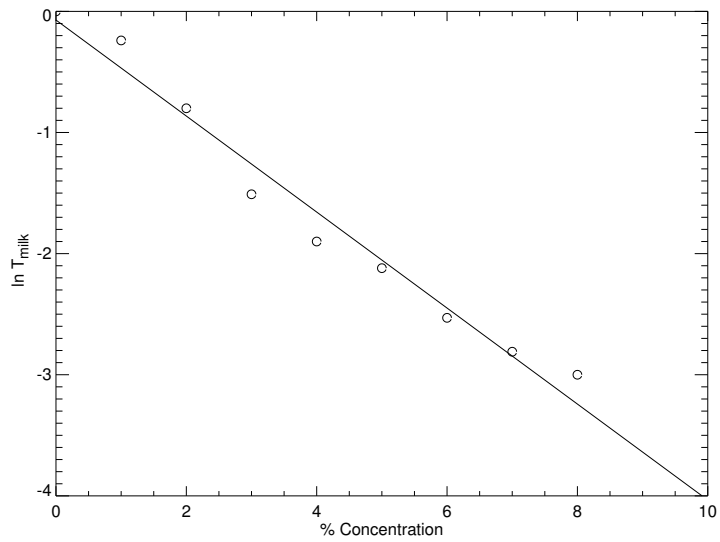

Figure 2: Sample plot

Detailed Mark Allocation

Section 1

A clear diagram illustrating geometry used with appropriate allocations	[1]
Optimal geometry used - as per model solution (laser close to ruler)	[1]
Multiple measurements made to ascertain errors involved	[1]
Correctly tabulated results	[1]
Sources of error including suggestion of ruler variation (suggested by non-ideal diffraction pattern)	[1]
Calculation of uncertainty	[1]
Final result	[2]
Allocated as per:	
$\pm 10\%$ (612, 748 nm)	[2]
$\pm 20\%$ (544, 816 nm)	[1]
\pm anything worse	[0]

Section 2

For evidence of practical determination of transmission rather than simply “back calculating”. Practical range 70 – 90%	[1]
For correct calculation of transmission (no more than 3 significant figures stated)	[1]

Section 3

Correct calculation with no more than 3 significant figures stated and an indication that the measurement was performed	[1]
--	-----

Section 4

Illustrative diagram including viewing geometry used, i.e. horizontal/vertical	[1]
For recognizing the difference between scattered light and the straight-through beam	[1]
For taking the T_{water} into account when calculating T_{milk}	[1]
Correctly calculated and tabulated results of T_{milk} with results within 20% of model solution	[1]
Using a graphical technique for determining the relationship between scatter angle and milk concentration	[1]
Using a graphical technique to extrapolate T_{milk} to 10% concentration	[1]
Final result for μ	[2]
Allocated as $\pm 40\%$ [2], $\pm 60\%$ [1], anything worse [0]	
A reasonable attempt to consider uncertainties	[1]
TOTAL	20

Plausibilitätsprüfung in der Nordström'schen Gravitationstheorie.

Siehe Mirman Vortrag, 2. Jahresw. Stunde 2. Grav.-Theorie.

Diff.-gl. 1. y. $\Delta(\gamma) = -\kappa \Sigma T_{cc} = \gamma \square \gamma$; für $\frac{\partial}{\partial t} = 0$ wird $\square = \Delta$; ΣT_{cc} gibt

(7)

Ausdruck für γ daraus:

Bewegungsgleichungen in erster Annäherung zur Verfeinerung des γ v.a. konstanten Coefficienten an der gewöhnlichen Gravitationskonstante κ :

Daraus für γ

Die Bewegungsgleichungen (2) für γ

Die in Gleichung (2a) für $\xi = \varphi \frac{c}{\sqrt{c^2 - q^2}}$ bedeutet die Bewegung.

Uebersetzung von Polarkoordinaten:

$$z^2 dy = F dt^2, \quad c^2 - q^2 = \frac{\varphi^2 c^4}{\xi^2}, \quad q^2 = c^2 \left(1 - \frac{\varphi^2 c^2}{\xi^2}\right) = (2\pi)^2$$

$$c^2 \left(1 - \frac{\varphi^2 c^2}{\xi^2}\right) \frac{z^2 dy^2}{\xi^2} = z^2 dx^2 + dz^2$$

$$dy = \frac{dz}{\sqrt{c^2 \left(1 - \frac{\varphi^2 c^2}{\xi^2}\right) \frac{z^2}{\xi^2} - z^2}} = \frac{dz}{\frac{c}{\xi} \cdot 2 \cdot \sqrt{\left(1 - \frac{\varphi^2 c^2}{\xi^2}\right) z^2 + 2 \frac{\varphi^2 c^2}{\xi^2} \cdot \kappa M \cdot z - \dots}}$$

$$z_1 + z_2 = -2 \frac{\varphi^2 \kappa M}{c^2 - \varphi^2 c^2}, \quad z_1, z_2 = -\frac{\varphi^2 \kappa^2 M^2 - F^2 \frac{\xi^2}{c^2}}{c^2 \left(\xi^2 - \varphi^2 c^2\right)}$$

Wird komplexe Integration verwendet:

$$\int \frac{2\pi}{\xi} \frac{dz}{\sqrt{\frac{\varphi^2 \kappa^2 M^2 - F^2}{c^2} - \left(\frac{c}{\xi} \left(1 - \frac{\varphi^2 c^2}{\xi^2}\right)\right) z^2}} = \pi \frac{F}{\sqrt{F^2 - \dots}}$$

$$= \pi \left(1 + \frac{1}{2} \frac{\varphi^2 \kappa^2 M^2}{\xi^2 F^2}\right); \text{ wobei ist } \sqrt{F^2 - \dots} = 2\pi a^3 \sqrt{\dots}$$

$$\kappa M = (2\pi)^2 \frac{a^3}{T^2}$$

$$\xi = \varphi c \left(\frac{2\pi a}{T}\right)$$

Example of «Old Masters» original theoretical work.
(From: The collected papers of Albert Einstein, Vol. 4, 1995)

$$\text{Daher } \int \frac{2\pi}{\xi} = \pi \left(1 + \frac{1}{2} \frac{\varphi^2 (2\pi)^2 \cdot a^3 T^2}{(2\pi)^4 \cdot \varphi^2 c^2 \cdot (2\pi)^2 a^6}\right) = \pi \left(1 + \dots\right)$$



Per Chr. Hemmer
Chief examiner

Commission for the Theoretical Competiton:

Per Chr. Hemmer
Alex Hansen
Eivind Hiis Hauge
Kjell Mork
Kåre Olaussen

Norwegian University of Science and Technology, Trondheim

&

Torgeir Engeland
Yuri Galperin
Anne Holt
Asbjørn Kildal
Leif Veseth

University of Oslo



27th INTERNATIONAL PHYSICS OLYMPIAD OSLO, NORWAY

**THEORETICAL COMPETITION
JULY 2 1996**

99

Time available: 5 hours

READ THIS FIRST :

1. Use only the pen provided
2. Use only the marked side of the paper
3. Each problem should be answered on separate sheets
4. In your answers please use primarily equations and numbers, and as little *text* as possible
5. Write at the top of *every* sheet in your report:
 - Your candidate number (IPhO identification number)
 - The problem number and section identification, e.g. 2/a
 - Number each sheet consecutively
6. Write on the front page the total number of sheets in your report



This set of problems consists of 7 pages.

PROBLEM 1

(The five parts of this problem are unrelated)

- a) Five 1Ω resistances are connected as shown in the figure. The resistance in the conducting wires (fully drawn lines) is negligible.

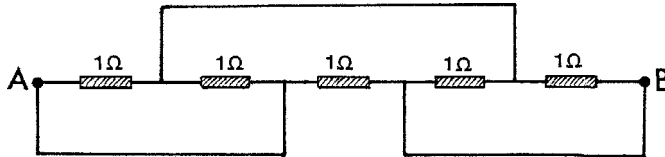

Determine the resulting resistance R between A and B. (1 point)

- b)

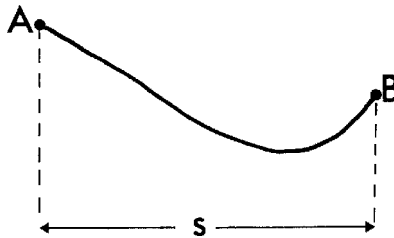

A skier starts from rest at point A and slides down the hill, without turning or braking. The friction coefficient is μ . When he stops at point B, his horizontal displacement is s . What is the height difference h between points A and B? (The velocity of the skier is small so that the additional pressure on the snow due to the curvature can be neglected. Neglect also the friction of air and the dependence of μ on the velocity of the skier.) (1.5 points)

- c) A thermally insulated piece of metal is heated under atmospheric pressure by an electric current so that it receives electric energy at a constant power P . This leads to an increase of the absolute temperature T of the metal with time t as follows:

$$T(t) = T_0 [1 + a(t - t_0)]^{1/4}.$$

Here a , t_0 and T_0 are constants. Determine the heat capacity $C_p(T)$ of the metal (temperature dependent in the temperature range of the experiment). (2 points)

d) A black plane surface at a constant high temperature T_h is parallel to another black plane surface at a constant lower temperature T_l . Between the plates is vacuum.

In order to reduce the heat flow due to radiation, a heat shield consisting of two thin black plates, thermally isolated from each other, is placed between the warm and the cold surfaces and parallel to these. After some time stationary conditions are obtained.

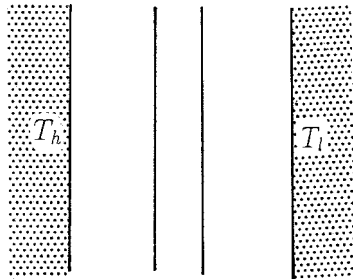

By what factor ξ is the stationary heat flow reduced due to the presence of the heat shield? Neglect end effects due to the finite size of the surfaces. (1.5 points)

e) Two straight and very long nonmagnetic conductors C_+ and C_- , insulated from each other, carry a current I in the positive and the negative z direction, respectively. The cross sections of the conductors (hatched in the figure) are limited by circles of diameter D in the x - y plane, with a distance $D/2$ between the centres. Thereby the resulting cross sections each have an area $(\frac{1}{12}\pi + \frac{1}{8}\sqrt{3})D^2$. The current in each conductor is uniformly distributed over the cross section.

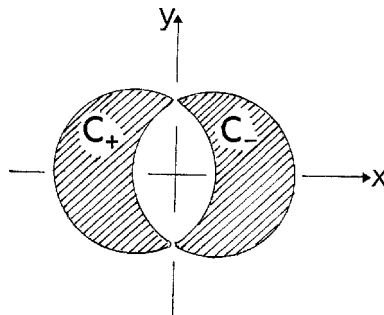

Determine the magnetic field $B(x,y)$ in the space between the conductors. (4 points)

PROBLEM 2

The space between a pair of coaxial cylindrical conductors is evacuated. The radius of the inner cylinder is a , and the inner radius of the outer cylinder is b , as shown in the figure below. The outer cylinder, called the anode, may be given a positive potential V relative to the inner cylinder. A static homogeneous magnetic field \vec{B} parallel to the cylinder axis, directed out of the plane of the figure, is also present. Induced charges in the conductors are neglected.

We study the dynamics of electrons with rest mass m and charge $-e$. The electrons are released at the surface of the inner cylinder.

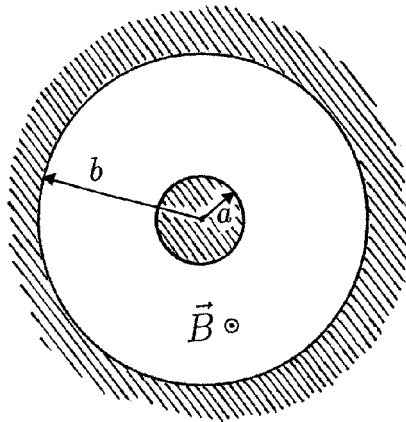

a) First the potential V is turned on, but $\vec{B} = 0$. An electron is set free with negligible velocity at the surface of the inner cylinder. Determine its speed v when it hits the anode. Give the answer both when a non-relativistic treatment is sufficient, and when it is not. (1 point)

For the remaining parts of this problem a non-relativistic treatment suffices.

b) Now $V = 0$, but the homogeneous magnetic field \vec{B} is present. An electron starts out with an initial velocity \vec{v}_0 in the radial direction. For magnetic fields larger than a critical value B_c , the electron will not reach the anode. Make a sketch of the trajectory of the electron when B is slightly more than B_c . Determine B_c . (2 points)

From now on *both* the potential V and the homogeneous magnetic field \vec{B} are present.

c) The magnetic field will give the electron a non-zero angular momentum L with respect to the cylinder axis. Write down an equation for the rate of change dL/dt of the angular momentum. Show that this equation implies that

$$L - keBr^2$$

is constant during the motion, where k is a definite pure number. Here r is the distance from the cylinder axis. Determine the value of k . (3 points)

d) Consider an electron, released from the inner cylinder with negligible velocity, that does not reach the anode, but has a maximal distance from the cylinder axis equal to r_m . Determine the speed v at the point where the radial distance is maximal, in terms of r_m . (1 point)

e) We are interested in using the magnetic field to regulate the electron current to the anode. For B larger than a critical magnetic field B_c , an electron, released with negligible velocity, will not reach the anode. Determine B_c . (1 point)

f) If the electrons are set free by heating the inner cylinder an electron will in general have an initial nonzero velocity at the surface of the inner cylinder. The component of the initial velocity parallel to \vec{B} is v_B , the components orthogonal to \vec{B} are v_r (in the radial direction) and v_ϕ (in the azimuthal direction, i.e. orthogonal to the radial direction).

Determine for this situation the critical magnetic field B_c for reaching the anode. (2 points)

PROBLEM 3

In this problem we consider some gross features of the magnitude of mid-ocean tides on earth. We simplify the problem by making the following assumptions:

- (i) The earth and the moon are considered to be an isolated system,
- (ii) the distance between the moon and the earth is assumed to be constant,
- (iii) the earth is assumed to be completely covered by an ocean,
- (iv) the dynamic effects of the rotation of the earth around its axis are neglected, and
- (v) the gravitational attraction of the earth can be determined as if all mass were concentrated at the centre of the earth.

The following data are given:

Mass of the earth: $M = 5.98 \cdot 10^{24}$ kg

Mass of the moon: $M_m = 7.3 \cdot 10^{22}$ kg

Radius of the earth: $R = 6.37 \cdot 10^6$ m

Distance between centre of the earth and centre of the moon:

$L = 3.84 \cdot 10^8$ m

The gravitational constant: $G = 6.67 \cdot 10^{-11}$ m³ kg⁻¹ s⁻².

a) The moon and the earth rotate with angular velocity ω about their common centre of mass, C . How far is C from the centre of the earth? (Denote this distance by l .)

Determine the numerical value of ω . (2 points)

We now use a frame of reference that is co-rotating with the moon and the center of the earth around C . In this frame of reference the shape of the liquid surface of the earth is static.

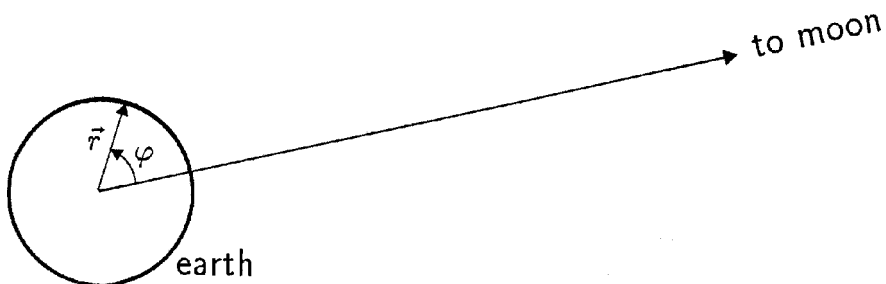

In the plane P through C and orthogonal to the axis of rotation the position of a point mass on the liquid surface of the earth can be described by polar coordinates r, φ as shown in the figure. Here r is the distance from the centre of the earth.

We will study the shape

$$r(\varphi) = R + h(\varphi)$$

of the liquid surface of the earth in the plane P .

b) Consider a mass point (mass m) on the liquid surface of the earth (in the plane P). In our frame of reference it is acted upon by a centrifugal force and by gravitational forces from the moon and the earth. Write down an expression for the potential energy corresponding to these three forces.

Note: Any force $F(r)$, radially directed with respect to some origin, is the negative derivative of a spherically symmetric potential energy $V(r)$:

$$F(r) = -V'(r). \quad (3 \text{ points})$$

c) Find, in terms of the given quantities M, M_m , etc, the approximate form $h(\varphi)$ of the tidal bulge. What is the difference in meters between high tide and low tide in this model?

You may use the approximate expression

$$\frac{1}{\sqrt{1 + a^2 - 2a \cos \theta}} \approx 1 + a \cos \theta + \frac{1}{2} a^2 (3 \cos^2 \theta - 1),$$

valid for a much less than unity.

In this analysis make simplifying approximations whenever they are reasonable. (5 points)



27th INTERNATIONAL PHYSICS OLYMPIAD

OSLO, NORWAY

THEORETICAL COMPETITION

JULY 2 1996

Solution Problem 1

a) The system of resistances can be redrawn as shown in the figure:

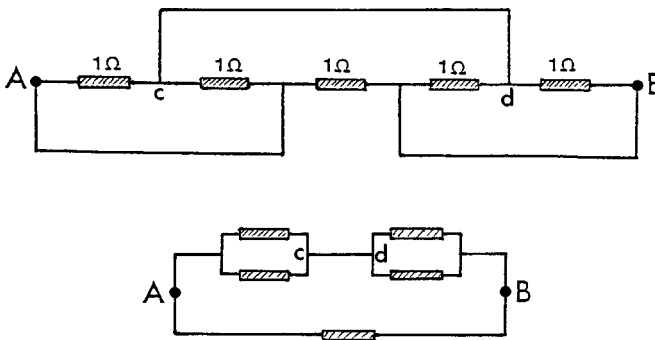

The equivalent drawing of the circuit shows that the resistance between point c and point A is 0.5Ω , and the same between point d and point B. The resistance between points A and B thus consists of two connections in parallel: the direct 1Ω connection and a connection consisting of two 0.5Ω resistances in series, in other words two parallel 1Ω connections. This yields

$$R = \underline{\underline{0.5 \Omega}} .$$

b) For a sufficiently short horizontal displacement Δs the path can be considered straight. If the corresponding length of the path element is ΔL , the friction force is given by

$$\mu mg \frac{\Delta s}{\Delta L}$$

and the work done by the friction force equals force times displacement:

$$\mu mg \frac{\Delta s}{\Delta L} \cdot \Delta L = \mu mg \Delta s.$$

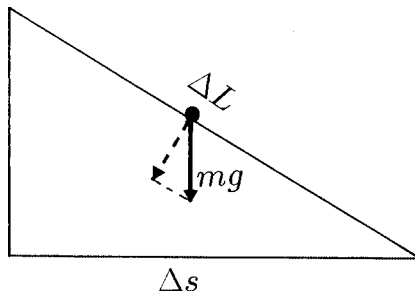

Adding up, we find that along the whole path the total work done by friction forces is $\mu mg s$. By energy conservation this must equal the decrease $mg h$ in potential energy of the skier. Hence

$$h = \underline{\underline{\mu s}}.$$

c) Let the temperature increase in a small time interval dt be dT . During this time interval the metal receives an energy $P dt$.

The heat capacity is the ratio between the energy supplied and the temperature increase:

$$C_p = \frac{P dt}{dT} = \frac{P}{dT/dt}.$$

The experimental results correspond to

$$\frac{dT}{dt} = \frac{T_0}{4} a [1 + a(t - t_0)]^{-3/4} = T_0 \frac{a}{4} \left(\frac{T_0}{T} \right)^3.$$

Hence

$$C_p = \frac{P}{dT/dt} = \frac{4P}{\underline{\underline{aT_0^4}}} T^3.$$

(*Comment:* At low, but not extremely low, temperatures heat capacities of metals follow such a T^3 law.)

d)

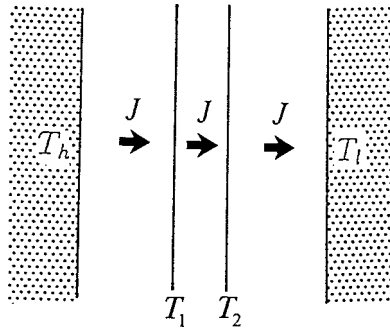

Under stationary conditions the net heat flow is the same everywhere:

$$J = \sigma(T_h^4 - T_1^4)$$

$$J = \sigma(T_1^4 - T_2^4)$$

$$J = \sigma(T_2^4 - T_l^4)$$

Adding these three equations we get

$$3J = \sigma(T_h^4 - T_l^4) = J_0,$$

where J_0 is the heat flow in the absence of the heat shield. Thus $\xi = J/J_0$ takes the value

$$\xi = \underline{\underline{1/3}}.$$

e) The magnetic field can be determined as the superposition of the fields of two *cylindrical* conductors, since the effects of the currents in the area of intersection cancel. Each of the cylindrical conductors must carry a larger current I' , determined so that the fraction I of it is carried by the actual cross section (the moon-shaped area). The ratio between the currents I and I' equals the ratio between the cross section areas:

$$\frac{I}{I'} = \frac{(\frac{\pi}{12} + \frac{\sqrt{3}}{8})D^2}{\frac{\pi}{4}D^2} = \frac{2\pi + 3\sqrt{3}}{6\pi}.$$

Inside one cylindrical conductor carrying a current I' Ampère's law yields at a distance r from the axis an azimuthal field

$$B_\phi = \frac{\mu_0}{2\pi r} \frac{I'\pi r^2}{\frac{\pi}{4}D^2} = \frac{2\mu_0 I' r}{\pi D^2}.$$

The cartesian components of this are

$$B_x = -B_\phi \frac{y}{r} = -\frac{2\mu_0 I' y}{\pi D^2}; \quad B_y = B_\phi \frac{x}{r} = \frac{2\mu_0 I' x}{\pi D^2}.$$

For the superposed fields, the currents are $\pm I'$ and the corresponding cylinder axes are located at $x = \mp D/4$.

The two x-components add up to zero, while the y-components yield

$$B_y = \frac{2\mu_0}{\pi D^2} [I'(x + D/4) - I'(x - D/4)] = \frac{\mu_0 I'}{\pi D} = \frac{6\mu_0 I}{(2\pi + 3\sqrt{3})D},$$

i.e., a *constant* field. The direction is along the positive y-axis.

Solution Problem 2

a) The potential energy gain eV is converted into kinetic energy. Thus

$$\frac{1}{2} m v^2 = eV \quad (\text{non-relativistically})$$

$$\frac{m c^2}{\sqrt{1 - v^2/c^2}} - m c^2 = eV \quad (\text{relativistically}).$$

Hence

$$v = \begin{cases} \sqrt{2eV/m} & (\text{non - relativistically}) \\ c \sqrt{1 - \left(\frac{m c^2}{m c^2 + eV}\right)^2} & (\text{relativistically}). \end{cases} \quad (1)$$

b) When $V=0$ the electron moves in a homogeneous static magnetic field. The magnetic Lorentz force acts orthogonal to the velocity and the electron will move in a circle. The initial velocity is tangential to the circle.

The radius R of the orbit (the ‘‘cyclotron radius’’) is determined by equating the centripetal force and the Lorentz force:

i.e.

$$eBv_0 = \frac{mv_0^2}{R},$$

$$B = \frac{mv_0}{eR}. \quad (2)$$

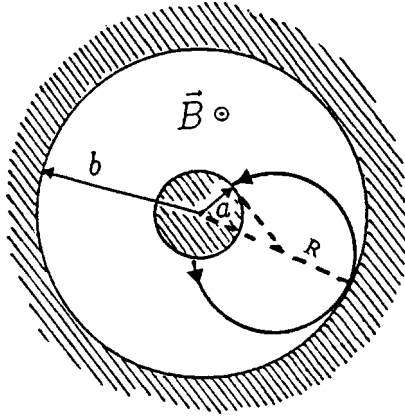

From the figure we see that in the critical case the radius R of the circle satisfies

$$\sqrt{a^2 + R^2} = b - R$$

By squaring we obtain

$$a^2 + R^2 = b^2 - 2bR + R^2,$$

i.e.

$$R = (b^2 - a^2) / 2b.$$

Insertion of this value for the radius into the expression (2) gives the critical field

$$B_c = \frac{mv_0}{eR} = \frac{2bm v_0}{(b^2 - a^2)e}.$$

c) The change in angular momentum with time is produced by a torque. Here the azimuthal component F_ϕ of the Lorentz force $\vec{F} = (-e)\vec{B} \times \vec{v}$ provides a torque $F_\phi r$. It is only the radial component $v_r = dr/dt$ of the velocity that provides an azimuthal Lorentz force. Hence

$$\frac{dL}{dt} = eBr \frac{dr}{dt},$$

which can be rewritten as

$$\frac{d}{dt} \left(L - \frac{eBr^2}{2} \right) = 0.$$

Hence

$$C = \underline{\underline{L - \frac{1}{2}eBr^2}} \quad (3)$$

is constant during the motion. The dimensionless number k in the problem text is thus $k = 1/2$.

d) We evaluate the constant C , equation (3), at the surface of the inner cylinder and at the maximal distance r_m :

$$0 - \frac{1}{2}eBa^2 = mvr_m - \frac{1}{2}eBr_m^2$$

which gives

$$v = \frac{eB(r_m^2 - a^2)}{2mr_m}. \quad (4)$$

Alternative solution: One may first determine the electric potential $V(r)$ as function of the radial distance. In cylindrical geometry the field falls off inversely proportional to r , which requires a logarithmic potential, $V(s) = c_1 \ln r + c_2$. When the two constants are determined to yield $V(a) = 0$ and $V(b) = V$ we have

$$V(r) = V \frac{\ln(r/a)}{\ln(b/a)}.$$

The gain in potential energy, $eV(r_m)$, is converted into kinetic energy:

$$\frac{1}{2}mv^2 = eV \frac{\ln(r_m/a)}{\ln(b/a)}.$$

Thus

$$v = \sqrt{\frac{2eV}{m} \frac{\ln(r_m/a)}{\ln(b/a)}}. \quad (5)$$

(4) and (5) seem to be different answers. This is only apparent since r_m is not an independent parameter, but determined by B and V so that the two answers are identical.

e) For the critical magnetic field the maximal distance r_m equals b , the radius of the outer cylinder, and the speed at the turning point is then

$$v = \frac{eB(b^2 - a^2)}{2mb}.$$

Since the Lorentz force does no work, the corresponding kinetic energy $\frac{1}{2}mv^2$ equals eV (question a):

$$v = \sqrt{2eV/m}$$

The last two equations are consistent when

$$\frac{eB(b^2 - a^2)}{2mb} = \sqrt{2eV/m}.$$

The critical magnetic field for current cut-off is therefore

$$B_c = \frac{2b}{b^2 - a^2} \sqrt{\frac{2mV}{e}}.$$

f) The Lorentz force has no component parallel to the magnetic field, and consequently the velocity component v_B is constant under the motion. The corresponding displacement parallel to the cylinder axis has no relevance for the question of reaching the anode.

Let v denote the final azimuthal speed of an electron that barely reaches the anode. Conservation of energy implies that

$$\frac{1}{2}m(v_B^2 + v_\phi^2 + v_r^2) + eV = \frac{1}{2}m(v_B^2 + v^2),$$

giving

$$v = \sqrt{v_r^2 + v_\phi^2 + 2eV/m}. \quad (6)$$

Evaluating the constant C in (3) at both cylinder surfaces for the critical situation we have

$$mv_\phi a - \frac{1}{2}eB_c a^2 = mvb - \frac{1}{2}eB_c b^2.$$

Insertion of the value (6) for the velocity v yields the critical field

$$B_c = \frac{2m(vb - v_\phi a)}{e(b^2 - a^2)} = \frac{2mb}{e(b^2 - a^2)} \left[\sqrt{v_r^2 + v_\phi^2 + 2eV/m} - v_\phi a/b \right].$$

Solution Problem 3

a) With the centre of the earth as origin, let the centre of mass C be located at \vec{l} . The distance l is determined by

$$Ml = M_m(L - l),$$

which gives

$$l = \frac{M_m}{M + M_m}L = \underline{4.63 \cdot 10^6 \text{ m}}, \quad (1)$$

less than R , and thus inside the earth.

The centrifugal force must balance the gravitational attraction between the moon and the earth:

$$M\omega^2 l = G \frac{MM_m}{L^2},$$

which gives

$$\omega = \sqrt{\frac{GM_m}{L^2 l}} = \sqrt{\frac{G(M + M_m)}{L^3}} = \underline{\underline{2.67 \cdot 10^{-6} \text{ s}^{-1}}}. \quad (2)$$

(This corresponds to a period $2\pi/\omega = 27.2$ days.) We have used (1) to eliminate l .

b) The potential energy of the mass point m consists of three contributions:

(1) Potential energy because of rotation (in the rotating frame of reference, see the problem text),

$$-\frac{1}{2}m\omega^2 r_1^2,$$

where \vec{r}_1 is the distance from C . This corresponds to the centrifugal force $m\omega^2 r_1$, directed outwards from C .

(2) Gravitational attraction to the earth,

$$-G \frac{mM}{r}.$$

(3) Gravitational attraction to the moon,

$$-G \frac{mM_m}{|\vec{r}_m|},$$

where \vec{r}_m is the distance from the moon.

Describing the position of m by polar coordinates r, ϕ in the plane orthogonal to the axis of rotation (see figure), we have

$$\vec{r}_1^2 = (\vec{r} - \vec{l})^2 = r^2 - 2rl\cos\phi + l^2.$$

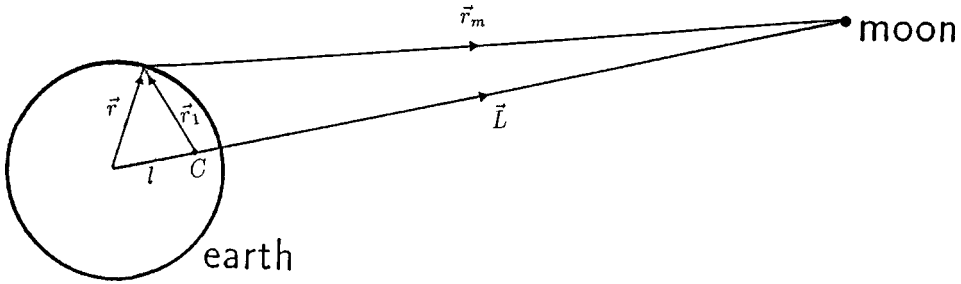

Adding the three potential energy contributions, we obtain

$$V(\vec{r}) = -\frac{1}{2}m\omega^2(r^2 - 2rl\cos\phi + l^2) - G \frac{mM}{r} - G \frac{mM_m}{|\vec{r}_m|}. \quad (3)$$

Here l is given by (1) and

$$|\vec{r}_m| = \sqrt{(\vec{l} - \vec{r})^2} = \sqrt{L^2 - 2\vec{L}\vec{r} + r^2} = L\sqrt{1 + (r/L)^2 - 2(r/L)\cos\phi}.$$

c) Since the ratio $r/L = a$ is very small, we may use the expansion

$$\frac{1}{\sqrt{1 + a^2 - 2a\cos\phi}} = 1 + a\cos\phi + a^2 \frac{1}{2}(3\cos^2\phi - 1).$$

Insertion into the expression (3) for the potential energy gives

$$V(r, \phi)/m = -\frac{1}{2}\omega^2 r^2 - \frac{GM}{r} - \frac{GM_m r^2}{2L^3}(3\cos^2\phi - 1), \quad (4)$$

apart from a constant. We have used that

$$m\omega^2 rl\cos\phi - GmM_m \frac{r}{L^2}\cos\phi = 0,$$

when the value of ω_2 , equation (2), is inserted.

The form of the liquid surface is such that a mass point has the same energy V *everywhere on the surface*. (This is equivalent to requiring no net force tangential to the surface.) Putting

$$r = R + h,$$

where the tide h is much smaller than R , we have approximately

$$\frac{1}{r} = \frac{1}{R+h} = \frac{1}{R} \cdot \frac{1}{1+(h/R)} \cong \frac{1}{R} \left(1 - \frac{h}{R}\right) = \frac{1}{R} - \frac{h}{R^2},$$

as well as

$$r^2 = R^2 + 2Rh + h^2 \cong R^2 + 2Rh.$$

Inserting this, and the value (2) of ω into (4), we have

$$V(r, \phi)/m = -\frac{G(M + M_m)R}{L^3} h + \frac{GM}{R^2} h - \frac{GM_m r^2}{2L^3} (3 \cos^2 \phi - 1), \quad (5)$$

again apart from a constant.

The magnitude of the first term on the right-hand side of (5) is a factor

$$\frac{(M + M_m)}{M} \left(\frac{R}{L}\right)^3 \cong 10^{-5}$$

smaller than the second term, thus negligible. If the remaining two terms in equation (5) compensate each other, i.e.,

$$h = \frac{M_m r^2 R^2}{2ML^3} (3 \cos^2 \phi - 1),$$

then the mass point m has the same energy everywhere on the surface. Here r^2 can safely be approximated by R^2 , giving the tidal bulge

$$h = \frac{M_m R^4}{2ML^3} (3 \cos^2 \phi - 1).$$

The largest value $h_{\max} = M_m R^4 / ML^3$ occurs for $\phi = 0$ or π , in the direction of the moon or in the opposite direction, while the smallest value

$$h_{\min} = -M_m R^4 / 2ML^3$$

corresponds to $\phi = \pi/2$ or $3\pi/2$.

The difference between high tide and low tide is therefore

$$h_{\max} - h_{\min} = \frac{3M_m R^4}{2ML^3} = \underline{\underline{0.54\text{m}}}.$$

(The values for high and low tide are determined up to an additive constant, but the difference is of course independent of this.)



Photo: Arnt Inge Vistnes

Here we see the Exam Officer, Michael Peachey (in the middle), with his helper Rod Jory (at the left), both from Australia, as well as the Chief examiner, Per Chr. Hemmer. The picture was taken in a silent moment during the theory examination. Michael and Rod had a lot of experience from the 1995 IPhO in Canberra, so their help was very effective and highly appreciated!



PART 5

Experimental Competition

Exam commission	page 142
Problems in English	page 143
The men behind the equipment	page 153
Model answers in English	page 154
Marking form (translated to English)	page 165
The last preparations (photos)	page 171
Examples of translated texts	page 172
Examples of student's papers	page 181
Photos from the experim. competition	page 190

Preparation of the experimental competition was carried out by:



Børge Holme



Tom Henning Johansen



Arnt Inge Vistnes

Photo: Geir Holm

Commission for the Experimental Competition:

Tom Henning Johansen
Børge Holme
Svenn L. Andersen
Carl Angell
Bjørn Berre[#]
Jan Kåre Bording
Magne Guttormsen
Vidar Hansen
Tor Haugset
Geir Helgesen[§]
Jan Holtet
Randi Haakenaasen
Trond Myklebust
Jon Samset[§]

from

University of Oslo, Oslo

§ : Institute for Energy Technology, Kjeller

: Agricultural University of Norway, Ås



27th INTERNATIONAL PHYSICS OLYMPIAD OSLO, NORWAY

EXPERIMENTAL COMPETITION
JULY 4 1996

Time available: 5 hours

READ THIS FIRST :

1. Use only the pen provided.
2. Use only the marked side of the paper.
3. No points will be given for error estimates except in 2c. However, it is expected that the correct number of significant figures are given.
4. When answering problems, use as little text as possible. You get full credit for an answer in the form of a numerical value, a drawing, or a graph with the proper definition of axes, etc.
5. Write on top of *every* sheet in your report:
 - Your candidate number (IPhO ID number)
 - The section number
 - The number of the sheet
6. Write on the front page the total number of sheets in your report, including graphs, drawings etc.
7. Ensure to include in your report the last page in this set used for answering section 2a and 3b, as well as all graphs requested.

SAFETY HAZARD: Be careful with the two vertical blades on the large stand. The blades are sharp!



This set of problems consists of 10 pages.

SUMMARY

The set of problems will cover a number of topics in physics. First, some mechanical properties of a physical pendulum will be explored, and you should be able to determine the acceleration of gravity. Then, magnetic forces are added to the pendulum. In this part the magnetic field from a permanent magnet is measured using an electronic sensor. The magnetic moment of a small permanent magnet will be determined. In addition, a question in optics in relation to the experimental setup will be asked.

INSTRUMENTATION

The following equipment is available (see Figure 1):

- A Large aluminium stand
- B Threaded brass rod with a tiny magnet in one end (painted white) (iron in the other).
- C 2 Nuts with a reflecting surface on one side
- D Oscillation period timer (clock) with digital display
- E Magnetic field (Hall) probe, attached to the large stand
- F 9 V battery
- G Multimeter, Fluke model 75
- H 2 Leads
- I Battery connector
- J Cylindrical stand made of PVC (grey plastic material)
- K Threaded rod with a piece of PVC and a magnet on the top
- L Small PVC cylinder of length 25.0 mm (to be used as a spacer)
- M Ruler

If you find that the large stand wiggles, try to move it to a different position on your table, or use a piece of paper to compensate for the non-flat surface.

The **pendulum** should be mounted as illustrated in Figure 1. The long threaded rod serves as a physical pendulum, hanging in the large stand by one of the nuts. The groove in the nut should rest on the two vertical blades on the large stand, thus forming a horizontal axis of rotation. The reflecting side of the nut is used in the oscillation period measurement, and should always face toward the timer.

The **timer** displays the period of the pendulum in seconds with an uncertainty of ± 1 ms. The timer has a small infrared light source on the right-hand side of the display (when viewed from the front), and an infrared detector mounted

close to the emitter. Infrared light from the emitter is reflected by the mirror side of the nut. The decimal point lights up when the reflected light hits the detector. For proper detection the timer can be adjusted vertically by a screw (see N in Figure 1). Depending on the adjustment, the decimal point will blink either once or twice each oscillation period. When it blinks twice, the display shows the period of oscillation, T . When it blinks once, the displayed number is $2T$. Another red dot appearing after the *last* digit indicates low battery. If battery needs to be replaced, ask for assistance.

The **multimeter** should be used as follows:

Use the “ $V\Omega$ ” and the “COM” inlets. Turn the switch to the DC voltage setting. The display then shows the DC voltage in volts. The uncertainty in the instrument for this setting is $\pm(0.4\%+1 \text{ digit})$.

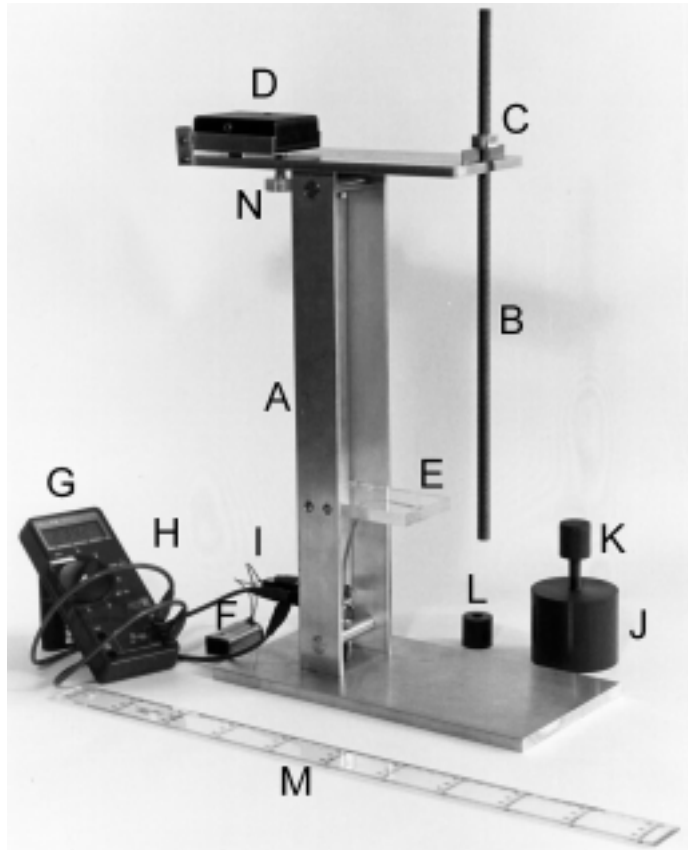

Figure 1. The instrumentation used.

SAFETY HAZARD: Be careful with the two vertical blades on the large stand. The blades are sharp!

THE PHYSICAL PENDULUM

A *physical pendulum* is an extended physical object of arbitrary shape that can rotate about a fixed axis. For a physical pendulum of mass M oscillating about a horizontal axis a distance, l , from the centre of mass, the period, T , for small angle oscillations is

$$T = \frac{2\pi}{\sqrt{g}} \sqrt{\frac{I}{Ml} + l} \quad (1)$$

Here g is the acceleration of gravity, and I is the moment of inertia of the pendulum about an axis parallel to the rotation axis but through the centre of mass.

Figure 2 shows a schematic drawing of the physical pendulum you will be using. The pendulum consists of a cylindrical metal rod, actually a long screw, having length L , average radius R , and at least one nut. The values of various dimensions and masses are summarised in Table 1. By turning the nut you can place it at any position along the rod. Figure 2 defines two distances, x and l , that describe the position of the rotation axis relative to the end of the rod and the centre of mass, respectively.

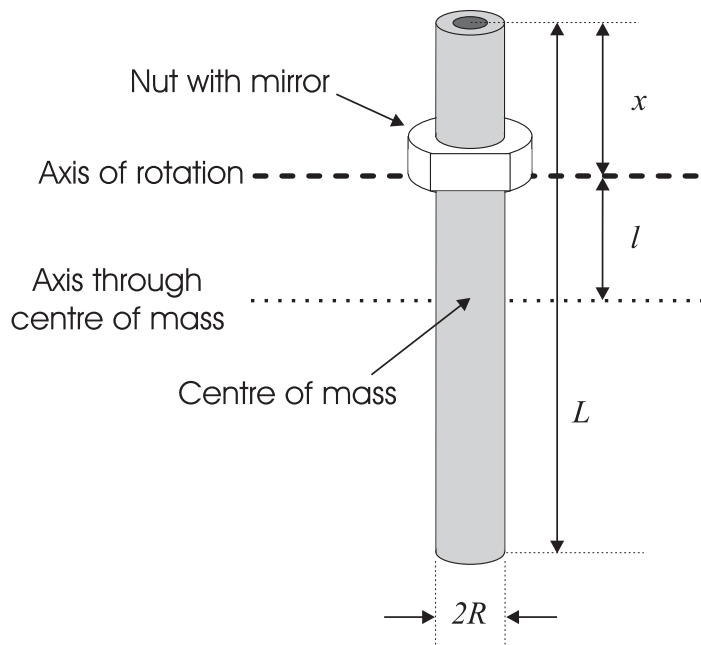

Figure 2: Schematic drawing of the pendulum with definition of important quantities.

Rod

Length	L	(400.0 ± 0.4) mm
Average radius	R	(4.4 ± 0.1) mm
Mass	M_{ROD}	$(210.2 \pm 0.2) \cdot 10^{-3}$ kg
Distance between screw threads		(1.5000 ± 0.0008) mm

Nut

Height	h	(9.50 ± 0.05) mm
Depth of groove	d	(0.55 ± 0.05) mm
Mass	M_{NUT}	$(4.89 \pm 0.03) \cdot 10^{-3}$ kg

Table 1: Dimensions and weights of the pendulum

A reminder from the front page: No points will be given for error estimates except in 2c. However, it is expected that the correct number of significant figures are given.

Section 1 : Period of oscillation versus rotation axis position (4 marks)

- Measure the oscillation period, T , as a function of the position x , and present the results in a table.
- Plot T as a function of x in a graph. Let 1 mm in the graph correspond to 1 mm in x and 1 ms in T . How many positions give an oscillation period equal to $T = 950$ ms, $T = 1000$ ms and $T = 1100$ ms, respectively?
- Determine the x and l value that correspond to the minimum value in T .

Section 2 : Determination of g (5 marks)

For a physical pendulum with a *fixed* moment of inertia, I , a given period, T , may in some cases be obtained for two different positions of the rotation axis. Let the corresponding distances between the rotation axis and the centre of mass be l_1 and l_2 . Then the following equation is valid:

$$l_1 l_2 = \frac{I}{M} \quad (2)$$

a) Figure 6 on the last page in this set illustrates a physical pendulum with an axis of rotation displaced a distance l_1 from the centre of mass. Use the information given in the figure caption to indicate *all* positions where a rotation axis parallel to the drawn axis can be placed without changing the oscillation period.

b) Obtain the local Oslo value for the acceleration of gravity g as accurately as possible. *Hint: There are more than one way of doing this. New measurements might be necessary.* Indicate *clearly* by equations, drawings, calculations etc. the method you used.

c) Estimate the uncertainty in your measurements and give the value of g with error margins.

Section 3 : Geometry of the optical timer (3 marks)

a) Use direct observation and reasoning to characterise, qualitatively as well as quantitatively, the shape of the reflecting surface of the nut (the mirror). (You may use the light from the light bulb in front of you).

Options (several may apply):

1. Plane mirror
2. Spherical mirror
3. Cylindrical mirror
4. Concave mirror
5. Convex mirror

In case of 2-5: Determine the radius of curvature.

b) Consider the light source to be a point source, and the detector a simple photoelectric device. Make an illustration of how the light from the emitter is reflected by the mirror on the nut in the experimental setup (side view and top view). Figure 7 on the last page in this set shows a vertical plane through the timer display (front view). Indicate in this figure the whole region where the reflected light hits this plane when the pendulum is vertical.

Section 4 : Measurement of magnetic field (4 marks)

You will now use an electronic sensor (Hall-effect sensor) to measure magnetic field. The device gives a voltage which depends linearly on the vertical field through the sensor. The field-voltage coefficient is $\Delta V / \Delta B = 22.6 \text{ V/T}$ (Volt/Tesla). As a consequence of its design the sensor gives a non-zero voltage (zero-offset voltage) in zero magnetic field. Neglect the earth's magnetic field.

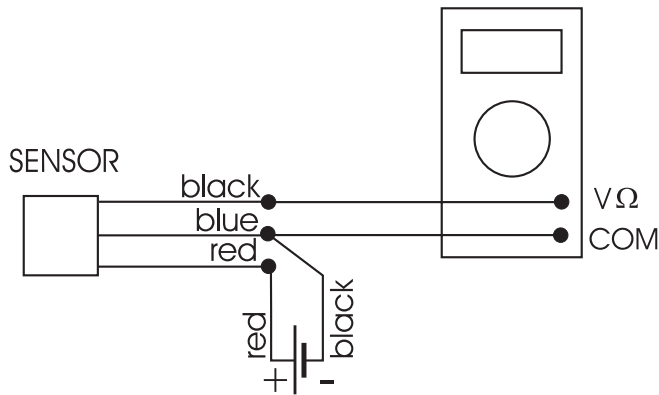

Figure 3: Schematics of the magnetic field detector system

a) Connect the sensor to the battery and voltmeter as shown above. Measure the zero-offset voltage, V_0 .

A permanent magnet shaped as a circular disk is mounted on a separate stand. The permanent magnet can be displaced vertically by rotating the mount screw, which is threaded identically to the pendulum rod. The dimensions of the permanent magnet are; thickness $t = 2.7$ mm, radius $r = 12.5$ mm.

b) Use the Hall sensor to measure the vertical magnetic field, B , from the permanent magnet along the cylinder axis, see Figure 4. Let the measurements cover the distance from $y = 26$ mm (use the spacer) to $y = 3.5$ mm, where $y = 1$ mm corresponds to the sensor and permanent magnet being in direct contact. Make a graph of your data for B versus y .

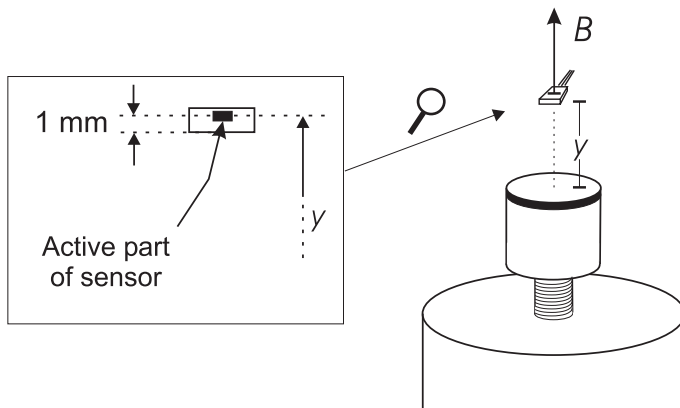

Figure 4: Definition of the distance y between top of magnet and the active part of the sensor.

c) It can be shown that the field along the axis of a cylindrical magnet is given by the formula

$$B(y) = B_0 \left[\frac{y+t}{\sqrt{(y+t)^2 + r^2}} - \frac{y}{\sqrt{y^2 + r^2}} \right] \quad (3)$$

where t is the cylinder thickness and r is the radius. The parameter B_0 characterizes the strength of the magnet. Find the value of B_0 for your permanent magnet.[§] Base your determination on two measured B -values obtained at different y .

Section 5 : Determination of magnetic dipole moment (4 marks)

A tiny magnet is attached to the white end of the pendulum rod. Mount the pendulum on the stand with its magnetic end down and with $x = 100 \text{ mm}$. Place the permanent magnet mount under the pendulum so that both the permanent magnet and the pendulum have common cylinder axis. The alignment should be done with the permanent magnet in its lowest position in the mount. (Always avoid close contact between the permanent magnet and the magnetic end of the pendulum.)

a) Let z denote the air gap spacing between the permanent magnet and the lower end of the pendulum. Measure the oscillation period, T , as function of the distance, z . The measurement series should cover the interval from $z = 25 \text{ mm}$ to $z = 5.5 \text{ mm}$ while you use as small oscillation amplitude as possible. Be aware of the possibility that the period timer might display $2T$ (see remark regarding the timer under *Instrumentation* above). Plot the observed T versus z .

b) With the additional magnetic interaction the pendulum has a period of oscillation, T , which varies with z according to the relation

$$\frac{1}{T^2} \propto 1 + \frac{\mu B_0}{Mgl} f(z) \quad (4)$$

Here \propto stand for “proportional to”, and μ is the magnetic dipole moment of the tiny magnet attached to the pendulum, and B_0 is the parameter determined in section 4c. The function $f(z)$ includes the variation in magnetic field with distance. In Figure 5 on the next page you find the particular $f(z)$ for our experiment, presented as a graph.

Select an appropriate point on the graph to determine the unknown magnetic moment μ .

[§] $2B_0$ is a material property called remanent magnetic induction, B_r .

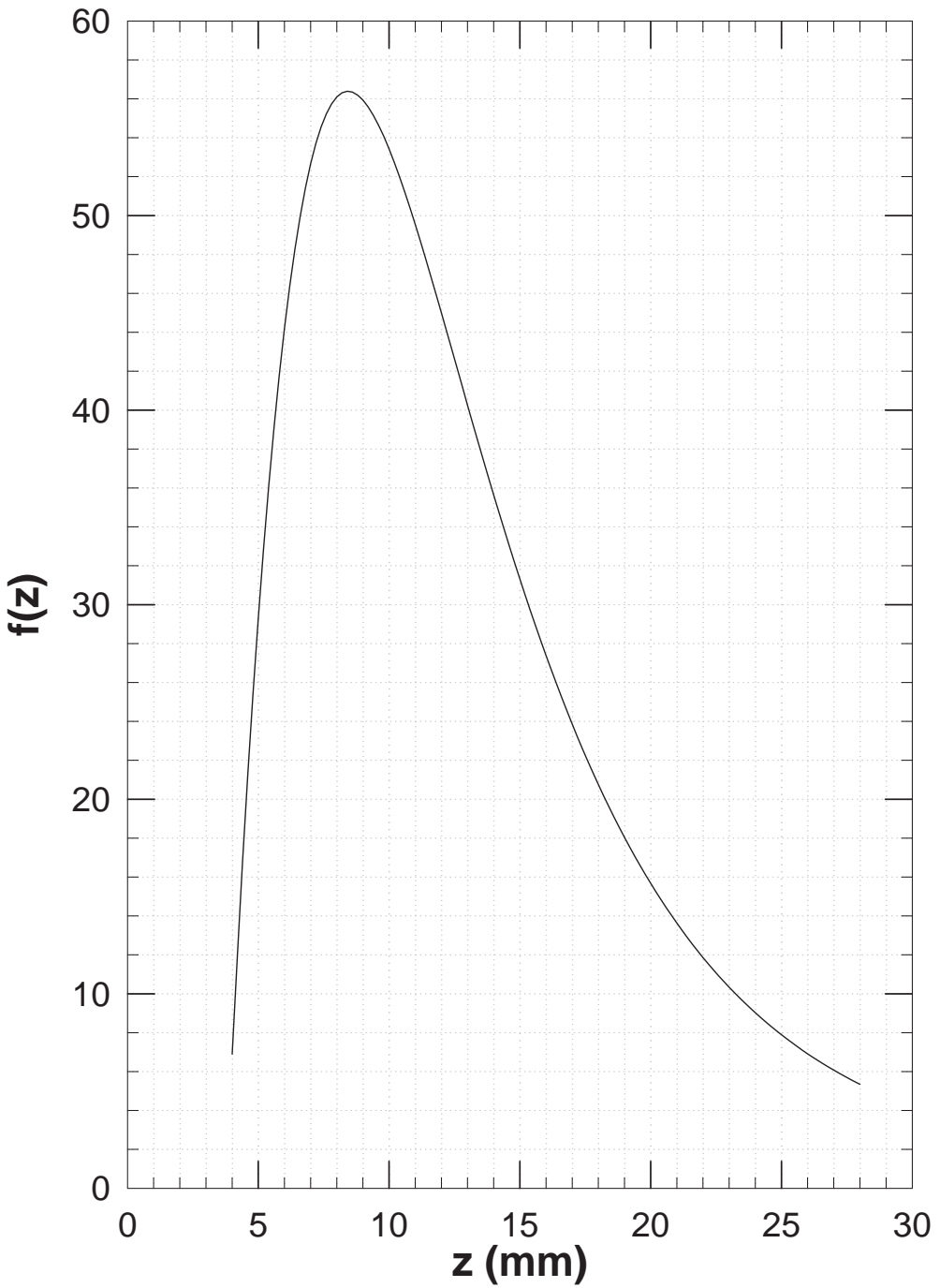

Figure 5. Graph of the dimension-less function $f(z)$ used in section 5b.

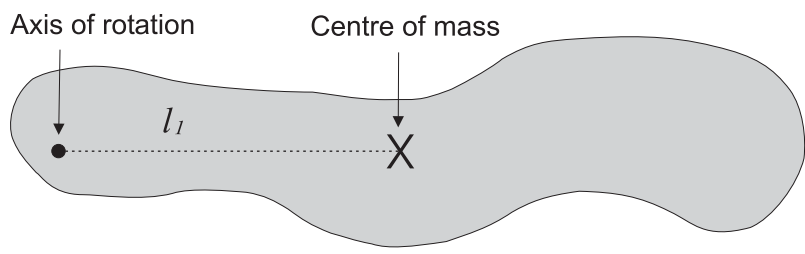

Figure 6. For use in section 2a. Mark all positions where a rotation axis (orthogonal to the plane of the paper) can be placed without changing the oscillation period. Assume for this pendulum (drawn on scale, 1:1) that $I/M = 2100 \text{ mm}^2$. (Note: In this booklet the size of this figure is about 75% of the size in the original examination paper.)

152

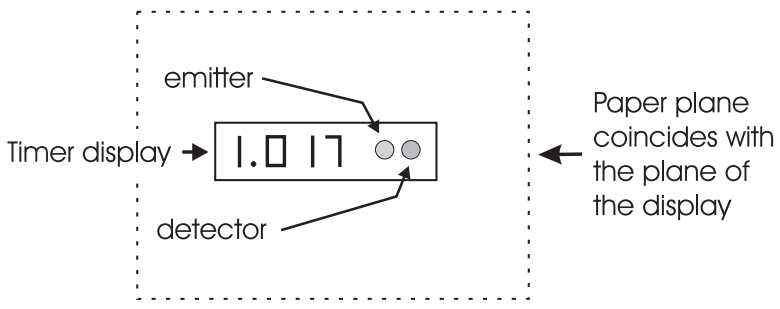

Figure 7. For use in section 3b. Indicate the whole area where the reflected light hits when the pendulum is vertical.

Include this page in your report!

The men behind the equipment

The equipment for the practical competition was constructed and manufactured at the Mechanics Workshop at the Department of Physics, University of Oslo (see picture below, from left to right: Tor Enger (head of the Mechanics Workshop), Pål Sundbye, Helge Michaelsen, Steinar Skaug Nilsen, and Arvid Andreassen).



Photo: Geir Holm

The electronic timer was designed and manufactured by Efim Brondz, Department of Physics, University of Oslo (see picture below). About 40.000 soldering points were completed manually, enabling the time-recording during the exam to be smooth and accurate.



Photo: Geir Holm



27th INTERNATIONAL PHYSICS OLYMPIAD OSLO, NORWAY

Model Answer for the EXPERIMENTAL COMPETITION JULY 4 1996

These model answers indicate what is required from the candidates to get the maximum score of 20 marks. Some times we have used slightly more text than required; paragraphs written in italic give additional comments. This practical exam will reward students with creativity, intuition and a thorough understanding of the physics involved.

Alternative solutions regarded as less elegant or more time consuming are printed in frames like this with white background.

Anticipated INCORRECT answers are printed on grey background and are included to point out places where the students may make mistakes or approximations without being aware of them.

Section 1:

1a) Threads are 1.50 mm/turn. Counted turns to measure position x .

Turn no.	0	10	20	30	40	50	60	70	80	90	100
x [mm]	10.0	25.0	40.0	55.0	70.0	85.0	100.0	115.0	130.0	145.0	160.0
T [ms]	1023	1005	989	976	967	964	969	987	1024	1094	1227
Turn no.	110	120	46	48	52	54					
x [mm]	175.0	190.0	79.0	82.0	88.0	91.0					
T [ms]	1490	2303	964	964	964	965					

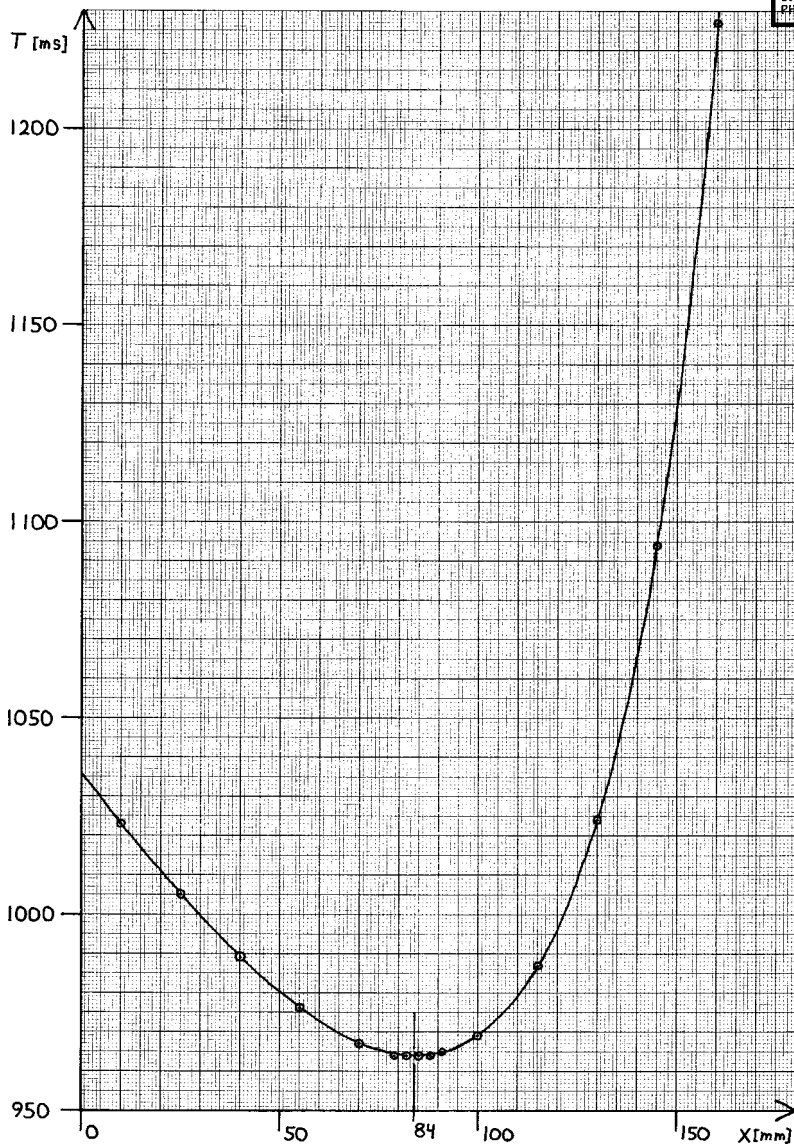

1b) Graph: $T(x)$, shown above.

$T = 950$ ms: NO positions

$T = 1000$ ms: 2 positions

$T = 1100$ ms: 1 position

If the answer is given as corresponding x -values, and these reflect the number of positions asked for, this answer will also be accepted.

1c) Minimum on graph: $x = 84$ mm, (estimated uncertainty 1 mm)

By balancing the pendulum horizontally: $l = 112.3$ mm + 0.55 mm = 113 mm

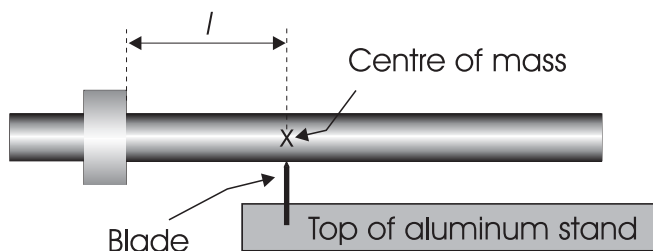

ALTERNATIVE 1c-1:

$$x_{CM} = \frac{M_{ROD}L - M_{NUT}h}{2M} + \frac{M_{NUT}}{M}x = 197.3 \text{ mm for } x = 84 \text{ mm}$$

$$\text{gives } l = 197.3 \text{ mm} - 84 \text{ mm} = 113 \text{ mm}$$

$$M = M_{ROD} + M_{NUT}, \quad h = 8.40 \text{ mm} = \text{height of nut minus two grooves.}$$

INCORRECT 1c-1: Assuming that the centre of mass for the pendulum coincides with the midpoint, $L/2$, of the rod gives $l = L/2 - x = 116$ mm.

(The exact position of the minimum on the graph is $x = 84.4$ mm. with $l = 112.8$ mm)

Section 2:

$$2a) \quad l_2 = \frac{I}{Ml_1} = \frac{2100 \text{ mm}^2}{60 \text{ mm}} = 35 \text{ mm}$$

See also Figure 6 on the next page

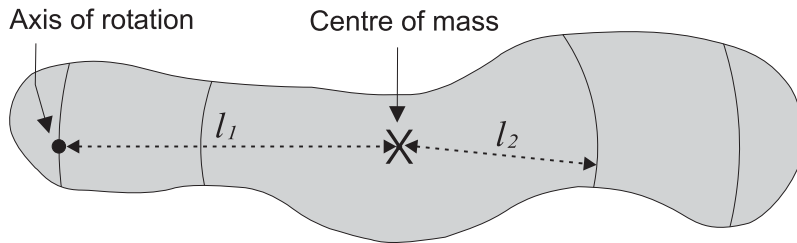

Figure 6. For use in section 2a. Mark all positions where a rotation axis (orthogonal to the plane of the paper) can be placed without changing the oscillation period. Assume for this pendulum (drawn on scale, 1:1) that $I/M = 2100 \text{ mm}^2$. (Note: In this booklet the size of this figure is about 75% of the size in the original examination paper.)

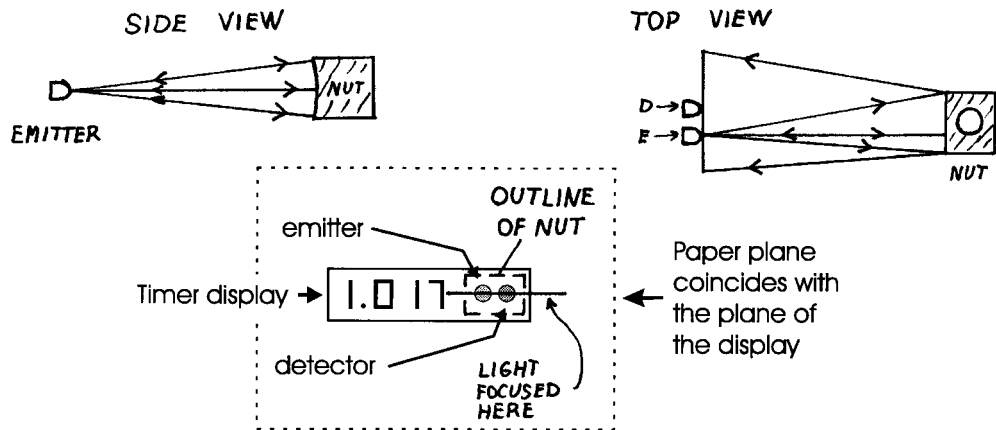

Figure 7. For use in section 3b. Indicate the whole area where the reflected light hits when the pendulum is vertical.

Include this page in your report!

2b) Simple method with small uncertainty: Inverted pendulum.

$$\text{Equation (1) + (2)} \Rightarrow T_1 = T_2 = \frac{2\pi}{\sqrt{g}} \sqrt{l_1 + l_2} \Leftrightarrow g = \frac{4\pi^2}{T_1^2} (l_1 + l_2)$$

NOTE: Independent of I/M !

Used both nuts with one nut at the end to maximise $l_1 + l_2$. Alternately adjusted nut positions until equal periods $T_1 = T_2$:

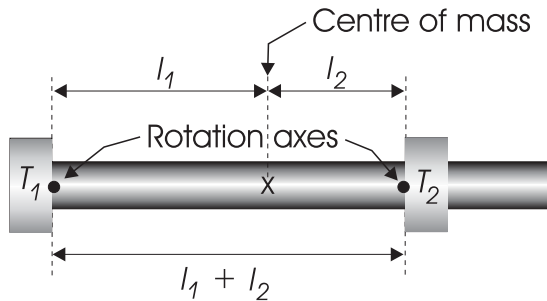

$$T_1 = T_2 = 1024 \text{ ms.}$$

Adding the depth of the two grooves to the measured distance between nuts:

$$l_1 + l_2 = (259.6 + 2 \cdot 0.55) \text{ mm} = 0.2607 \text{ m}$$

$$g = \frac{4\pi^2}{T_1^2} (l_1 + l_2) = \frac{4 \cdot 3.1416^2 \cdot 0.2607 \text{ m}}{(1.024 \text{ s})^2} = \underline{\underline{9.815 \text{ m/s}^2}}$$

ALTERNATIVE 2b-1: Finding $I(x)$. Correct but time consuming.

It is possible to derive an expression for I as a function of x . By making sensible approximations, this gives:

$$\frac{I(x)}{M} = \left[\frac{L^2}{12} + \frac{M_{NUT}}{M} \left(\frac{L+h}{2} - x \right)^2 \right] \frac{M_{ROD}}{M}$$

which is accurate to within 0.03 %. Using the correct expression for I as a function of x :

$$I(x) = x_{CM} - x = \frac{M_{ROD}L - M_{NUT}h}{2M} - \frac{M_{ROD}}{M}x = 195.3 \text{ mm} - 0.9773x,$$

equation (1) can be used on any point (x, T) to find g . Choosing the point (85 mm, 964 ms) gives:

$$g = \frac{4\pi^2}{T^2} \left[\frac{I(x)}{M \cdot l(x)} + l(x) \right] = \frac{4 \cdot 3.1416^2 \cdot 0.2311 \text{ m}}{(0.964 \text{ s})^2} = \underline{\underline{9.818 \text{ m/s}^2}}$$



Using the minimum point on the graph in the way shown below is wrong, since the curve in **1b**), $T(x) = \frac{2\pi}{\sqrt{g}} \sqrt{\frac{I(x)}{M \cdot l(x)} + l(x)}$ with $I(x)/M$ and $l(x)$ given above, describes a continuum of **different** pendulums with changing $I(x)$ and moving centre of mass.

Equation (1): $T = \frac{2\pi}{\sqrt{g}} \sqrt{\frac{I}{Ml}} + l$ describes **one** pendulum with fixed I , and does not apply to the curve in **1b**).

INCORRECT 2b-1: At the minimum point we have from Equation (2) and **1c**):

$$l_1 = l_2 = l = \sqrt{I/M} = (113 \pm 1) \text{ mm} \quad \text{Equation (1) becomes}$$

$$T_{\min} = \frac{2\pi}{\sqrt{g}} \sqrt{\frac{l^2}{l} + l} = \frac{2\pi}{\sqrt{g}} \sqrt{2l} \quad \text{and}$$

$$g = \frac{8\pi^2 l}{T_{\min}^2} = \frac{8 \cdot 3.1416^2 \cdot 0.113 \text{ m}}{(0.964 \text{ s})^2} = 9.60 \text{ m/s}^2$$

Another source of error which may accidentally give a reasonable value is using the wrong value $l = (116 \pm 1) \text{ mm}$ from «INCORRECT 1c-1»:

$$\text{INCORRECT 2b-2: } g = \frac{8\pi^2 l}{T_{\min}^2} = \frac{8 \cdot 3.1416^2 \cdot 0.116 \text{ m}}{(0.964 \text{ s})^2} = 9.86 \text{ m/s}^2$$

Totally neglecting the mass of the nut but remembering the expression for the moment of inertia for a thin rod about a perpendicular axis through the centre of mass, $I = ML^2/12$, gives from equation (2) for the minimum point: $l^2 = I/M = L^2/12 = 0.01333 \text{ m}^2$. This value is accidentally only 0.15% smaller than the correct value for $I(x)/M$ at the minimum point on the curve in **1b**):

$$\frac{I(x = 84.43 \text{ mm})}{M} = \left[\frac{L^2}{12} + \frac{M_{\text{NUT}}}{M} \left(\frac{L+h}{2} - x \right)^2 \right] \frac{M_{\text{ROD}}}{M} = 0.01335 \text{ m}^2.$$

(continued on next page)



(cont.)

Neglecting the term $\frac{M_{NUT}}{M} \left(\frac{L+h}{2} - 84.43 \text{ mm} \right)^2 = 0.00033 \text{ m}^2$ is nearly compensated by omitting the factor $\frac{M_{ROD}}{M} = 0.977$. However, each of these approximations are of the order of 2.5 %, well above the accuracy that can be achieved.

INCORRECT 2b-3: At the minimum point equation (2) gives $l^2 = \frac{I}{M} = \frac{L^2}{12}$. Then

$$T_{\min} = \frac{2\pi}{\sqrt{g}} \sqrt{2l} = \frac{2\pi}{\sqrt{g}} \sqrt{\frac{2L}{\sqrt{12}}} = \frac{2\pi}{\sqrt{g}} \sqrt{\frac{L}{\sqrt{3}}} \quad \text{and}$$

$$g = \frac{4\pi^2 L}{\sqrt{3} T_{\min}^2} = \frac{4 \cdot 3.1416^2 \cdot 0.4000 \text{ m}}{1.7321 \cdot (0.964 \text{ s})^2} = 9.81 \text{ m/s}^2$$

2c) Estimating uncertainty in the logarithmic expression for g :

$$\text{Let } S \equiv l_1 + l_2 \Rightarrow g = \frac{4\pi^2 S}{T^2}$$

$$\Delta S = 0.3 \text{ mm} \quad \Delta T = 1 \text{ ms}$$

$$\frac{\Delta g}{g} = \sqrt{\left(\frac{\Delta S}{S} \right)^2 + \left(-2 \frac{\Delta T}{T} \right)^2} = \sqrt{\left(\frac{0.3 \text{ mm}}{260.7 \text{ mm}} \right)^2 + \left(2 \cdot \frac{1 \text{ ms}}{1024 \text{ ms}} \right)^2}$$

$$= \sqrt{(0.0012)^2 + (0.0020)^2} = 0.0023 = 0.23\%$$

$$\Delta g = 0.0023 \cdot 9.815 \text{ m/s}^2 = 0.022 \text{ m/s}^2$$

$$\underline{\underline{g = (9.82 \pm 0.02) \text{ m/s}^2}}$$

The incorrect methods INCORRECT 2b-1, 2b-2 and 2b-3 have a similar expressions for g as above. With $\Delta l = 1 \text{ mm}$ in INCORRECT 2b-1 and 2b-2 we get $\Delta g = 0.09 \text{ m/s}^2$.

INCORRECT 2b-3 should have $\Delta l = 0.3 \text{ mm}$ and $\Delta g = 0.02 \text{ m/s}^2$.



ALTERNATIVE 3 has a very complicated x dependence in g . Instead of differentiating $g(x)$ it is easier to insert the two values $x+\Delta x$ and $x-\Delta x$ in the expression in brackets [], thus finding an estimate for Δl] and then using the same formula as above.

(The official local value for g , measured in the basement of the adjacent building to where the practical exam was held is $g = 9.8190178 \text{ m/s}^2$ with uncertainty in the last digit.)

Section 3.

- 3a) 3. Cylindrical mirror
4. Concave mirror

Radius of curvature of cylinder, $r = 145 \text{ mm}$. (*Uncertainty approx. $\pm 5 \text{ mm}$, not asked for.*)

(In this set-up the emitter and detector are placed at the cylinder axis. The radius of curvature is then the distance between the emitter/detector and the mirror.)

- 3b) Three drawings, see Figure 7 on page 4 in this Model Answers.

(The key to understanding this set-up is that for a concave cylindrical mirror with a point source at the cylinder axis, the reflected light will be focused back onto the cylinder axis as a line segment of length twice the width of the mirror.)

Section 4.

- 4a) $V_0 = 2.464 \text{ V}$ (*This value may be different for each set-up.*)

- 4b) Threads are 1.50 mm/turn . Measured $V(y)$ for each turn. Calculated

$$B(y) = [V(y) - V_0] \frac{\Delta B}{\Delta V} = [V(y) - V_0] / \frac{\Delta V}{\Delta B}. \quad (\text{Table not requested})$$

See graph on next page.



Graph: $B(y)$:

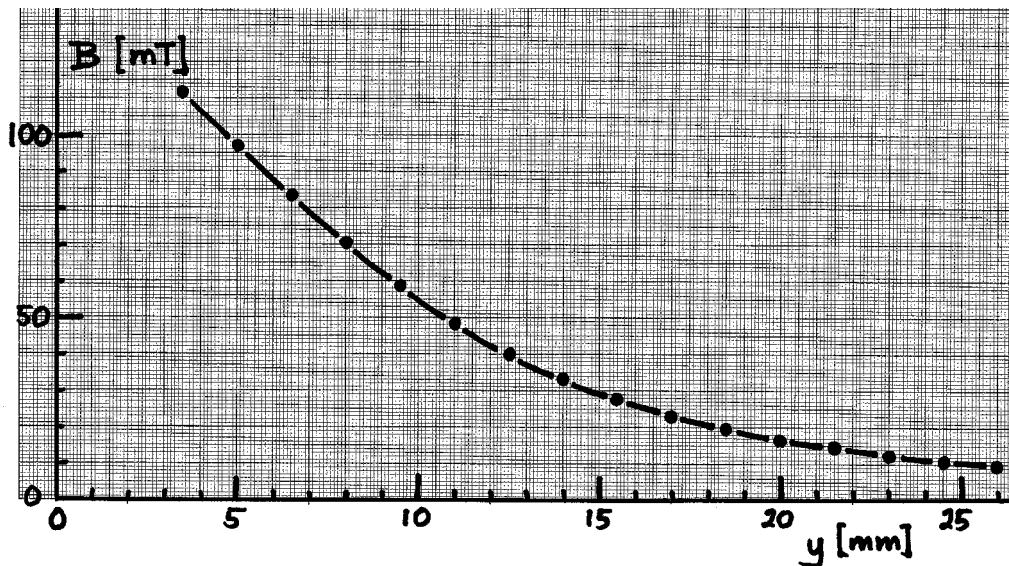

4c)

$$B_0 = B(y) \left[\frac{y+t}{\sqrt{(y+t)^2 + r^2}} - \frac{y}{\sqrt{y^2 + r^2}} \right]^{-1}$$

The point (11 mm, 48.5 mT) gives $B_0 = 0.621$ T and (20 mm, 16.8 mT) gives $B_0 = 0.601$ T.
Mean value: $B_0 = 0.61$ T (This value may vary for different magnets.)

Section 5:

5a) Used the spacer and measured $T(z)$ from $z = 25$ mm to 5.5 mm. (Table is not requested.)

See plot on next page.

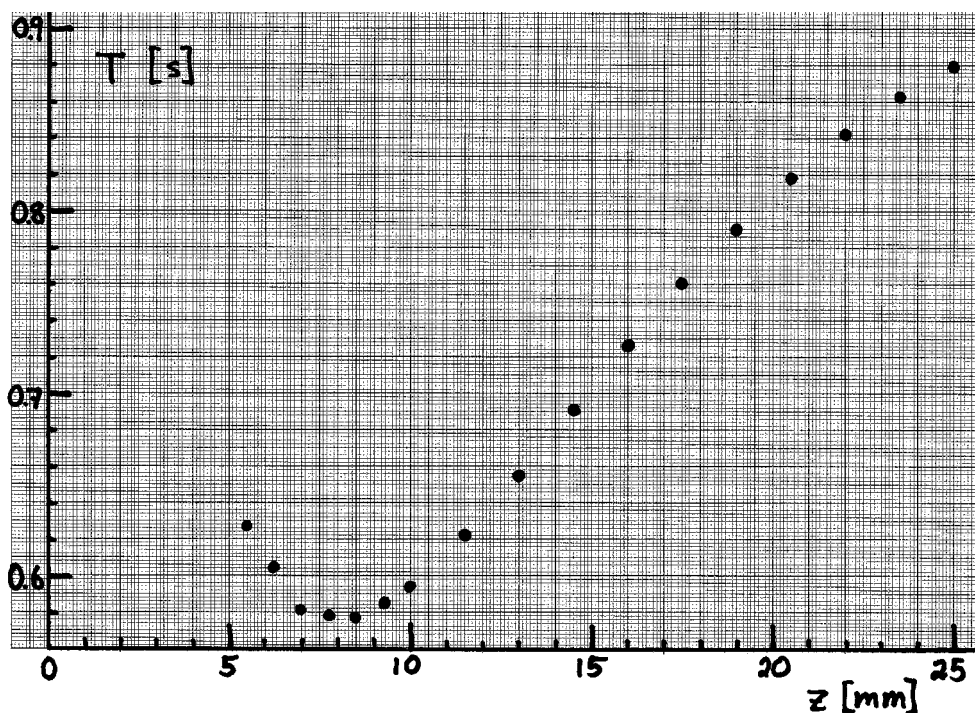
Graph: $T(z)$:

5b) $l(x = 100 \text{ mm}) = 97.6 \text{ mm}$ (by balancing the pendulum or by calculation as in 1c).

$$M = M_{\text{ROD}} + M_{\text{NUT}}$$

Proportionality means: $\frac{1}{T^2} = a \left[1 + \frac{\mu B_0}{Mgl} f(z) \right]$ where a is a proportionality constant. Setting

$B_0 = 0$ corresponds to having an infinitely weak magnet or no magnet at all. Removing the

large magnet gives: $T_0 = 968 \text{ ms}$ and $\frac{1}{T_0^2} = a \left[1 + 0 \cdot \frac{\mu}{Mgl} f(z) \right]$ or $a = \frac{1}{T_0^2}$.

Selecting the point where $f(z)$, see Fig. 5, changes the least with z , i.e., at the maximum, one has $f_{\text{max}} = 56.3$. This point must correspond to the minimum oscillation period, which is measured to be $T_{\text{min}} = 576 \text{ ms}$.

We will often need the factor

$$\frac{Mgl}{B_0} = \frac{0.215 \text{ kg} \cdot 9.82 \text{ m/s}^2 \cdot 0.0976 \text{ m}}{0.61 \text{ T}} = 0.338 \text{ Am}^2.$$



The magnetic moment then becomes

$$\mu = \frac{Mgl}{B_0} \frac{1}{f_{max}} \left[\left(\frac{T_0}{T} \right)^2 - 1 \right] = \frac{0.338 \text{ Am}^2}{56.3} \left[\left(\frac{968}{576} \right)^2 - 1 \right] = \underline{\underline{1.1 \cdot 10^{-2} \text{ Am}^2}}$$

ALTERNATIVE 5b-1: *Not what is asked for:* Using two points to eliminate the

proportionality constant a : Equation (4) or $\frac{1}{T^2} = a \left[1 + \frac{\mu B_0}{Mgl} f(z) \right]$ gives:

$$aT_1^2 \left[1 + \frac{\mu B_0}{Mgl} f(z_1) \right] = aT_2^2 \left[1 + \frac{\mu B_0}{Mgl} f(z_2) \right]$$

$$T_1^2 + T_1^2 \frac{\mu B_0}{Mgl} f(z_1) = T_2^2 + T_2^2 \frac{\mu B_0}{Mgl} f(z_2)$$

$$\frac{\mu B_0}{Mgl} [T_1^2 f(z_1) - T_2^2 f(z_2)] = T_2^2 - T_1^2$$

$$\mu = \frac{Mgl}{B_0} \cdot \frac{T_2^2 - T_1^2}{T_1^2 f(z_1) - T_2^2 f(z_2)}$$

Choosing two points ($z_1 = 7 \text{ mm}$, $T_1 = 580.5 \text{ ms}$) and ($z_2 = 22 \text{ mm}$, $T_2 = 841 \text{ ms}$). Reading from the graph $f(z_1) = 56.0$ and $f(z_2) = 12.0$ we get

$$\mu = 0.338 \text{ Am}^2 \cdot \frac{841^2 - 580^2}{580^2 \cdot 56.0 - 841^2 \cdot 12.0} = \underline{\underline{1.2 \cdot 10^{-2} \text{ Am}^2}}$$

Candidate:	Total score: + + + + =
Country:	Marker's name:
Language:	Comment:

Marking Form

**for the *Experimental Competition* at the
27th International Physics Olympiad
Oslo, Norway
July 4, 1996**

To the marker: Carefully read through the candidate's exam papers and compare with the model answer. You may use the transparencies (handed out) when checking the graph in **1b**) and the drawing in **2a**). When encountering words or sentences that require translation, postpone marking of this part until you have consulted the interpreter.

Use the table below and mark a circle around the point values to be subtracted. Add vertically the points for each subsection and calculate the score.

NB: Give score 0 if the value comes out negative for any subsection.

Add the scores for each subsection and write the sum in the 'Total score'- box at the upper right. Keep decimals all the way.

If you have questions, consult the marking leader. Good luck, and remember that you will have to defend your marking in front of the team leaders.

(Note: The terms "INCORRECT 2b-1" found in the table for subsection 2c) and similar terms elsewhere, refer to the Model Answer, in which anticipated incorrect answers were included and numbered for easy reference.)

Subsection 1a)	<i>Deficiency</i>	<i>Subtract</i>
	No answer	1.0
	x lacks unit	0.1
	Other than 0 or 1 decimal in x	0.1
	x does not cover the interval 10 mm - 160 mm	0.1
	T lacks unit	0.1
	T given with other than 1 or 0.5 millisecond accuracy	0.1
	Fewer than 11 measuring points (15 mm sep.). Subtr. up to	0.2
	Systematic error in x (e.g. if measured from the top of the nut so that the first $x = 0$ mm)	0.2
	If not aware of doubling of the timer period	0.2
Other (specify):		
Score for subsection 1a: 1.0 -		=

Subsection 1b)	<i>Deficiency</i>	<i>Subtract</i>
	No answer	1.0
	Lacks " x [(m)m]" on horizontal axis	0.1
	1 mm on paper does not correspond to 1 mm in x	0.1
	Fewer than 3 numbers on horizontal axis	0.1
	Lacks " T [(m)s]" on vertical axis	0.1
	1 mm on paper does not correspond to 1 ms in T	0.1
	Fewer than 3 numbers on vertical axis	0.1
	Measuring points not clearly shown (as circles or crosses)	0.2
	More than 5 ms deviation in more than 2 measuring points on the graph	0.2
	Wrong answer to the questions (x -values give full score if correct number of values: 0, 2, 1)	0.2
Other (specify):		
Score for subsection 1b): 1.0 -		=

Subsection 1c)	<i>Deficiency</i>	<i>Subtract</i>
	No answer	2.0
	x outside the interval 81 - 87 mm. Subtract up to	0.4
	x lacks unit	0.1
	x given more (or less) accurately than in whole millimeters	0.3
	l lacks unit	0.1
	l given more (or less) accurately than the nearest mm	0.3
	Wrong formula (e.g. $l = 200.0$ mm - x) or something other than $l = x_{CM} - x$	0.6
	If it is not possible to see which method was used to find the center of mass	0.2
Other (specify):		
Score for subsection 1c): 2.0 -		=

Subsection 2a)	<i>Deficiency</i>	<i>Subtract</i>
	No answer	1.5
	If drawn straight (vertical) lines	0.4
	If points are drawn	0.5
	Other than 4 regions are drawn	0.5
	Inaccurate drawing ($> \pm 2$ mm)	0.3
	Lacks the values $l_1 = 60$ mm, $l_2 = 35$ mm on figure or text	0.3
Other (specify):		
Score for subsection 2a):		1.5 - =

Subsection 2b)	<i>Deficiency</i>	<i>Subtract</i>
	No answer	2.5
	Lacks (derivation of) formula for g	0.3
	For INVERTED PENDULUM: Lacks figure	0.2
	Values from possible new measurements not given	0.3
	Incomplete calculations	0.3
	If hard to see which method was used	0.4
	Used the formula for INVERTED PENDULUM but read l_1 and l_2 from graph in 1b) by a horizontal line for a certain T	1.5
	Used one of the other incorrect methods	2.0
	Other than 3 (or 4) significant figures in the answer	0.3
	g lacks unit m/s^2	0.1
Other (specify):		
Score for subsection 2b):		2.5 - =

Subsection 2c)	<i>Deficiency</i>	<i>Subtract</i>
	No answer	2.5
	Wrong expression for $\Delta g/g$ or Δg . Subtract up to	0.5
	For INVERTED PENDULUM: If 0.3 mm $> \Delta(l_1+l_2) > 0.5$ mm	0.2
	For ALTERNATIVE 2c-1: If $\Delta/l > 0.1$ mm	0.2
	For INCORRECT 2c-1 and 2c-2: If 1 mm $> \Delta l > 2$ mm	0.2
	For INCORRECT 2c-3: If 0.3 mm $> \Delta L > 0.4$ mm	0.2
	For all methods: If $\Delta T \neq 1$ (or 0.5) ms	0.2
	Error in the calculation of Δg	0.2
	Lacks answer including $g \pm \Delta g$ with 2 decimals	0.2
	$g \pm \Delta g$ lacks unit	0.1
Other (specify):		
Score for subsection 2c):		2.5 - =

Subsection 3a)	<i>Deficiency</i>	<i>Subtract</i>
	No answer	1.0
	Lacks point 3. cylindrical mirror	0.3
	Lacks point 4. concave mirror	0.3
	Includes other points (1, 2 or 5), subtract per wrong point:	0.3
	Lacks value for radius of curvature	0.4
	If $r < 130$ mm or $r > 160$ mm, subtract up to	0.2
	If r is given more accurately than hole millimeters	0.2
Other (specify):		
Score for subsection 3a): 1.0 -		=

Subsection 3b)	<i>Deficiency</i>	<i>Subtract</i>
	No answer	2.0
	Lacks side view figure	0.6
	Errors or deficiencies in the side view figure. Subtract up to	0.4
	Lacks top view figure	0.6
	Errors or deficiencies in the top view figure. Subtract up to	0.4
	Drawing shows light focused to a point	0.3
	Drawing shows light spread out over an ill defined or wrongly shaped surface	0.3
	Line/surface is not horizontal	0.2
	Line/point/surface not centered symmetrically on detector	0.2
	Line/point/surface has length different from twice the width of the nut (i.e. outside the interval 10 - 30 mm)	0.1
Other (specify):		
Score for subsection 3b): 2.0 -		=

Subsection 4a)	<i>Deficiency</i>	<i>Subtract</i>
	No answer	1.0
	V_o lacks unit V	0.1
	Less than 3 decimals in V_o	0.1
	Incorrect couplings (would give $V_o < 2.3$ V or $V_o > 2.9$ V)	0.8
Other (specify):		
Score for subsection 4a): 1.0 -		=

Subsection 4b)	<i>Deficiency</i>	<i>Subtract</i>
	No answer	1.5
	Forgotten V_o or other errors in formula for B	0.2
	Lacks “y [(m)m]” on horizontal axis	0.1
	Fewer than 3 numbers on horizontal axis	0.1
	Lacks “ B [(m)T]” on vertical axis	0.1
	Fewer than 3 numbers on vertical axis	0.1
	Fewer than 9 measuring points. Subtract up to	0.2
	Measuring points do not cover the interval 3.5 mm - 26 mm	0.2
	Measuring points not clearly shown (as circles or crosses)	0.1
	Error in data or unreasonably large spread in measuring points. Subtract up to	0.5
Other (specify):		
Score for subsection 4b): 1.5 -		=

Subsection 4c)	<i>Deficiency</i>	<i>Subtract</i>
	No answer	1.5
	Incorrect formula for B_o	0.3
	If used only one measuring point	0.4
	If used untypical points on the graph	0.3
	Errors in calculation of mean value for B_o	0.2
	B_o lacks unit T	0.1
	Other than two significant figures in (the mean value of) B_o	0.2
	$B_o < 0.4$ T or $B_o > 0.7$ T. Subtract up to	0.2
Other (specify):		
Score for subsection 4c): 1.5 -		=

Subsection 5a)	<i>Deficiency</i>	<i>Subtract</i>
	No answer	1.0
	Lacks “ z [(m)m]” on horizontal axis	0.1
	Fewer than 3 numbers on horizontal axis	0.1
	Lacks “ T [(m)s]” on vertical axis	0.1
	Fewer than 3 numbers on vertical axis	0.1
	Fewer than 8 measuring points. Subtract up to	0.2
	Measuring points not clearly shown (as circles or crosses)	0.1
	Measuring points do not cover the interval 5.5 mm - 25 mm	0.2
	Error in data (e.g. plotted $2T$ instead of T) or unreasonably large spread in measuring points. Subtr. up to	0.5
Other (specify):		
Score for subsection 5a):		1.0 - =

Subsection 5b)	<i>Deficiency</i>	<i>Subtract</i>
	No answer	3.0
	Forgotten center of mass displacement in l (used $l = 100$ mm)	0.3
	Used ALTERNATIVE 5b-1	1.0
	Lacks method for finding the proportionality factor a	2.5
	Not found correct proportionality factor a	0.3
	Used another point than the maximum of $f(z)$	0.1
	Incorrect reading of $f(z)$	0.1
	Used M_{ROD} or another incorrect value for M	0.2
	Incorrect calculation of μ	0.3
	μ lacks unit (Am^2 or J/T)	0.2
	More than 2 significant figures in μ	0.3
Other (specify):		
Score for subsection 5b):		3.0 - =

Total points:

Total for section 1 (max. 4 points):
Total for section 2 (max. 5 points):
Total for section 3 (max. 3 points):
Total for section 4 (max. 4 points):
Total for section 5 (max. 4 points):

The last preparations

The problem for the experimental competition was discussed by the leaders and the organizers the evening before the exam. At this meeting the equipment was demonstrated for the first time (picture).



Photo: Børge Holme

After the meeting had agreed on the final text (in English), the problems had to be translated into the remaining 36 languages. One PC was available for each nation for the translation process (see picture below). The last nation finished their translation at about 4:30 a.m. in the morning, and the competition started at 0830. Busy time for the organizers! Examples of the different translations are given on the following pages.



Photo: Børge Holme

28th International Physics Olympiad

Sudbury, Canada

THEORETICAL COMPETITION

Thursday, July 17th, 1997

Time Available: 5 hours

Read This First:

1. Use only the pen provided.
2. Use only the front side of the answer sheets and paper.
3. In your answers please use *as little text as possible*; express yourself primarily in equations, numbers and figures. **Summarize your results on the answer sheet.**
4. Please indicate on the first page the total number of pages you used.
5. At the end of the exam please put your answer sheets, pages and graphs in order.

This set of problems consists of 11 pages.

Examination prepared at: University of British Columbia
Department of Physics and Astronomy
Committee Chair: Chris Waltham

Hosted by: Laurentian University

Theory Question No.1

Scaling

(a) A small mass hangs on the end of a massless ideal spring and oscillates up and down at its natural frequency f . If the spring is cut in half and the mass reattached at the end, what is the new frequency f' ? (1.5 marks)

(b) The radius of a hydrogen atom in its ground state is $a_0 = 0.0529$ nm (the “Bohr radius”). What is the radius a' of a “muonic-hydrogen” atom in which the electron is replaced by an identically charged muon, with mass 207 times that of the electron? Assume the proton mass is much larger than that of the muon and electron. (2 marks)

(c) The mean temperature of the earth is $T = 287$ K. What would the new mean temperature T' be if the mean distance between the earth and the sun was reduced by 1%? (2 marks)

(d) On a given day, the air is dry and has a density $\rho = 1.2500$ kg/m³. The next day the humidity has increased and the air is 2% by mass water vapour. The pressure and temperature are the same as the day before. What is the air density ρ' now? (2 marks)

Mean molecular weight of dry air: 28.8 (g/mol)

Molecular weight of water: 18 (g/mol)

Assume ideal-gas behaviour.

(e) A type of helicopter can hover if the mechanical power output of its engine is P . If another helicopter is made which is an exact $\frac{1}{2}$ -scale replica (in all linear dimensions) of the first, what mechanical power P' is required for it to hover? (2.5 marks)

Theory Question 1: Answer Sheet

STUDENT CODE: _____

(a) Frequency f' :

(b) Radius a' :

(c) Temperature T' :

(d) Density ρ' :

(e) Power P' :

Theory Question No.2

Nuclear Masses and Stability

All energies in this question are expressed in MeV - millions of electron volts.

One MeV = 1.6×10^{-13} J, but it is not necessary to know this to solve the problem.

The mass M of an atomic nucleus with Z protons and N neutrons (i.e. the mass number $A = N + Z$) is the sum of masses of the free constituent nucleons (protons and neutrons) minus the binding energy B/c^2 .

$$Mc^2 = Zm_p c^2 + Nm_n c^2 - B$$

The graph shown below plots the maximum value of B/A for a given value of A , vs. A . The greater the value of B/A , in general, the more stable is the nucleus.

Binding Energy per Nucleon

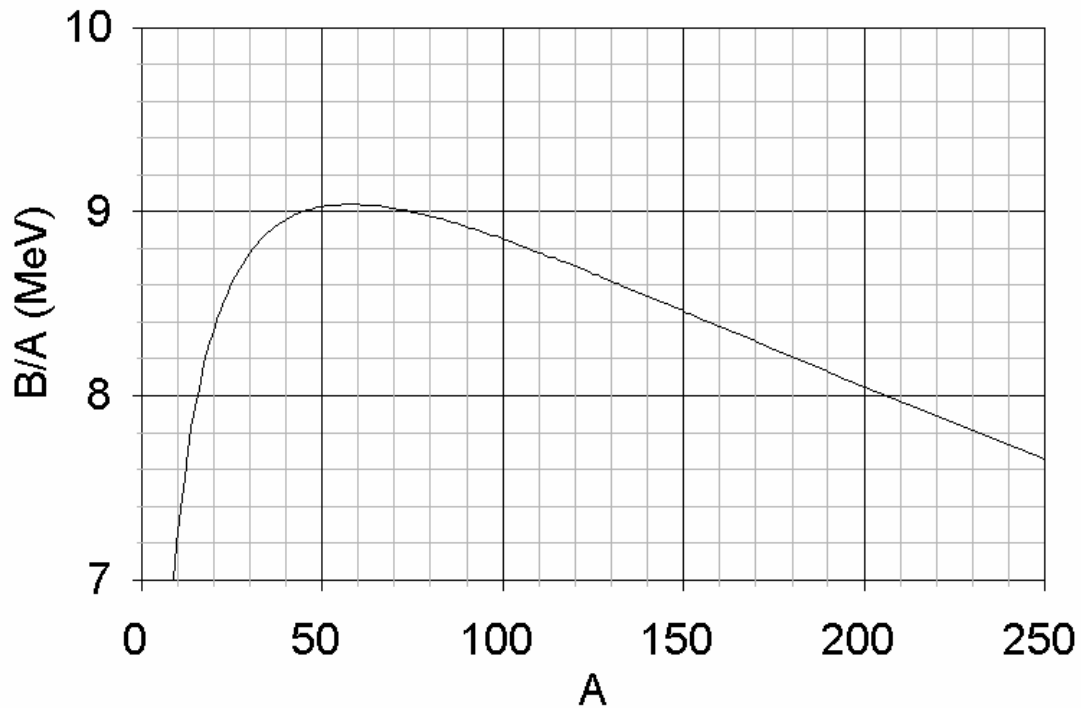

(a) Above a certain mass number A_α , nuclei have binding energies which are always small enough to allow the emission of alpha-particles ($A=4$). Use a linear approximation to this curve above $A = 100$ to estimate A_α . (3 marks)

For this model, assume the following:

- Both initial and final nuclei are represented on this curve.
- The total binding energy of the alpha-particle is given by $B_4 = 25.0$ MeV (this cannot be read off the graph!).

(b) The binding energy of an atomic nucleus with Z protons and N neutrons ($A=N+Z$) is given by a semi-empirical formula:

$$B = a_v A - a_s A^{2/3} - a_c Z^2 A^{-1/3} - a_a \frac{(N - Z)^2}{A} - \delta$$

The value of δ is given by:

$$+ a_p A^{-3/4} \text{ for odd-N/odd-Z nuclei}$$

$$0 \text{ for even-N/odd-Z or odd-N/even-Z nuclei}$$

$$- a_p A^{-3/4} \text{ for even-N/even-Z nuclei}$$

The values of the coefficients are:

$$a_v = 15.8 \text{ MeV}; a_s = 16.8 \text{ MeV}; a_c = 0.72 \text{ MeV}; a_a = 23.5 \text{ MeV}; a_p = 33.5 \text{ MeV}.$$

(i) Derive an expression for the proton number Z_{max} of the nucleus with the largest binding energy for a given mass number A . Ignore the δ -term for this part only. (2 marks)

(ii) What is the value of Z for the $A = 200$ nucleus with the largest B/A ? Include the effect of the δ -term. (2 marks)

(iii) Consider the three nuclei with $A = 128$ listed in the table on the answer sheet. Determine which ones are energetically stable and which ones have sufficient energy to decay by the processes listed below. Determine Z_{max} as defined in part (i) and fill out the table on your answer sheet.

In filling out the table, please:

- Mark processes which are energetically allowed thus: \checkmark
- Mark processes which are NOT energetically allowed thus: 0
- Consider only transitions between these three nuclei.

Decay processes:

- (1) β^- - decay; emission from the nucleus of an electron
- (2) β^+ - decay; emission from the nucleus of a positron
- (3) $\beta^-\beta^-$ - decay; emission from the nucleus of two electrons simultaneously
- (4) Electron capture; capture of an *atomic* electron by the nucleus.

The rest mass energy of an electron (and positron) is $m_e c^2 = 0.51$ MeV; that of a proton is $m_p c^2 = 938.27$ MeV; that of a neutron is $m_n c^2 = 939.57$ MeV.

(3 marks)

Question 2: Answer Sheet

STUDENT CODE: _____

(a) Numerical value for A_α :

(b) (i) Expression for Z_{max} :

(b) (ii) Numerical value of Z :

(b) (iii)

Nucleus/Process	β^- - decay	β^+ - decay	Electron-capture	$\beta^-\beta^-$ - decay
$^{128}_{53}\text{I}$				
$^{128}_{54}\text{Xe}$				
$^{128}_{55}\text{Cs}$				

Notation : $^A_Z X$

X = Chemical Symbol

Theory Question No.3

Solar-Powered Aircraft

We wish to design an aircraft which will stay aloft using solar power alone. The most efficient type of layout is one with a wing whose top surface is completely covered in solar cells. The cells supply electrical power with which the motor drives the propeller.

Consider a wing of rectangular plan-form with span l , chord (width) c ; the wing area is $S = cl$, and the wing aspect ratio $A = l/c$. We can get an approximate idea of the wing's performance by considering a slice of air of height x and length l being deflected downward at a small angle ε with only a very small change in speed. Control surfaces can be used to select an optimal value of ε for flight. This simple model corresponds closely to reality if $x = \pi l/4$, and we can assume this to be the case. The total mass of the aircraft is M and it flies horizontally with velocity \bar{v} relative to the surrounding air. In the following calculations consider only the air flow around the wing.

Top view of aircraft (in its own frame of reference):

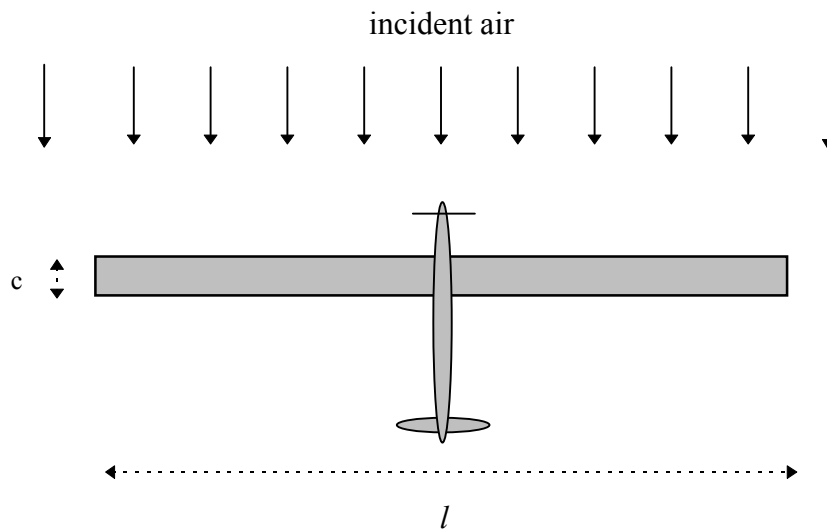

Side view of wing (in a frame of reference moving with the aircraft):

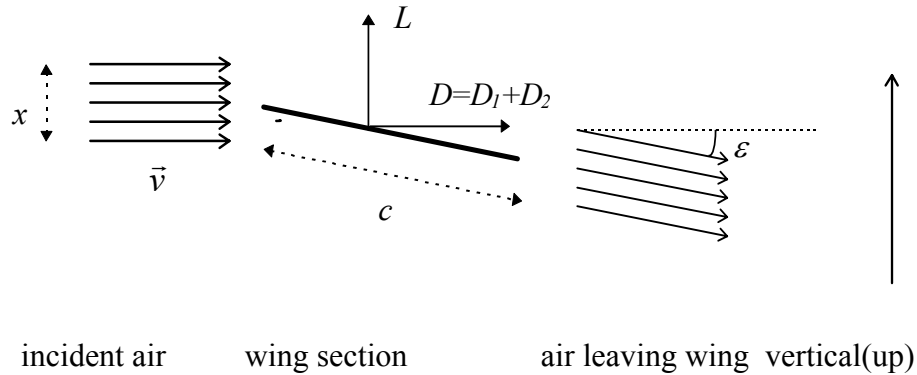

Ignore the modification of the airflow due to the propeller.

(a) Consider the change in momentum of the air moving past the wing, with *no* change in speed while it does so. Derive expressions for the vertical lift force L and the horizontal drag force D_1 on the wing in terms of wing dimensions, v , ϵ , and the air density ρ . Assume the direction of air flow is always parallel to the plane of the side-view diagram. (3 marks)

(b) There is an additional horizontal drag force D_2 caused by the friction of air flowing over the surface of the wing. The air slows slightly, with a change of speed Δv ($\ll 1\%$ of v) given by:

$$\frac{\Delta v}{v} = \frac{f}{A}$$

The value of f is independent of ϵ .

Find an expression (in terms of M, f, A, S, ρ and g - the acceleration due to gravity) for the flight speed v_0 corresponding to a minimum power being needed to maintain this aircraft in flight at constant altitude and velocity. Neglect terms of order $(\epsilon^2 f)$ or higher. (3 marks)

You may find the following small angle approximation useful:

$$1 - \cos \epsilon \approx \frac{\sin^2 \epsilon}{2}$$

(c) On the answer sheet, sketch a graph of power P versus flight speed v . Show the separate contributions to the power needed from the two sources of drag. Find an expression (in terms of M, f, A, S, ρ and g) for the minimum power, P_{min} . (2 marks)

(d) If the solar cells can supply sufficient energy so that the electric motors and propellers generate mechanical power of $I = 10$ watts per square metre of wing area, calculate the maximum wing loading Mg/S (N/m^2) for this power and flight speed v_0 (m/s). Assume $\rho = 1.25 \text{ kg/m}^3$, $f = 0.004$, $A = 10$. (2 marks)

Question 3: Answer Sheet

STUDENT CODE: _____

(a) Expression for L :

(a) Expression for D_1 :

(b) Expression for D_2 :

(b) Expression for v_0 :

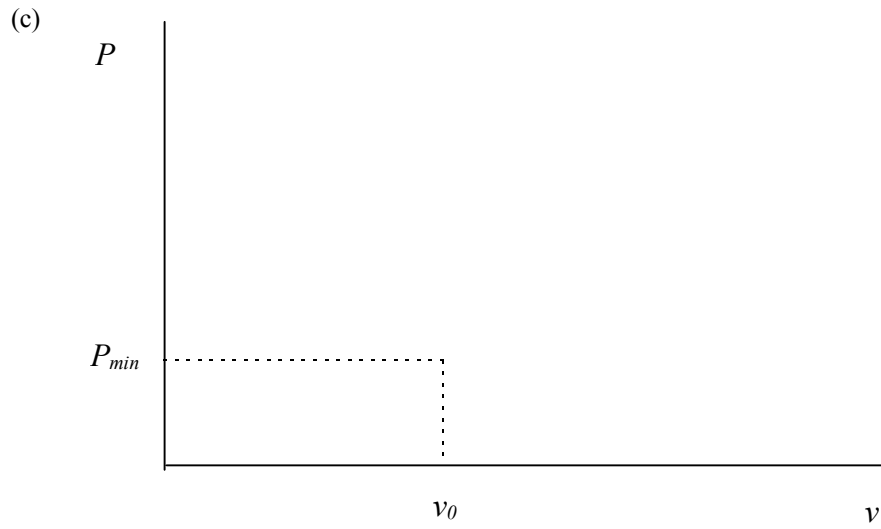

(c) Expression for P_{min} :

(d) Maximum value of Mg/S :

(d) Numerical value of v_0 :

29th International Physics Olympiad

Reykjavík, Iceland

Theoretical competition

Saturday, July 4th, 1998

9 a.m. – 2 p.m.

Read this first:

1. Use only the pen provided.
2. Use only the front side of the answer sheets.
3. Use *as little text as possible* in your answers; express yourself primarily with equations, numbers and figures. **Summarize your results on the answer sheets.**
4. For anything but your answers and your graphs use the blank answer sheets. This applies e.g. when you are asked to *show that ...* and also for all calculations you want to be considered for evaluation.
5. You may often be able to solve later parts of a problem without having solved the previous ones. In such cases you may take the result of a previous part as given, in the form stated in the problem text.
6. Please indicate on all sheets your team name, student number, number of page and total number of pages. On the blank answer sheets also indicate the problem number.
7. At the end of the exam please put your answer sheets in order. You may leave on your table material which you do not wish to be evaluated.

This set of problems consists of 11 pages in total.

Examination prepared at:

University of Iceland, Department of Physics, in collaboration with physicists from the National Energy Authority.

1 Rolling of a hexagonal prism¹

1.1 Problem text

Consider a long, solid, rigid, regular hexagonal prism like a common type of pencil (Figure 1.1). The mass of the prism is M and it is uniformly distributed. The length of each side of the cross-sectional hexagon is a . The moment of inertia I of the hexagonal prism about its central axis is

$$I = \frac{5}{12}Ma^2 \quad (1.1)$$

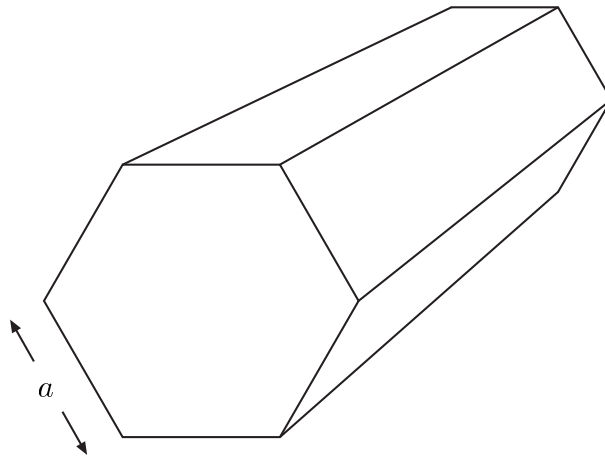

Figure 1.1: A solid prism with the cross section of a regular hexagon.

The moment of inertia I' about an edge of the prism is

$$I' = \frac{17}{12}Ma^2 \quad (1.2)$$

a) (3.5 points) The prism is initially at rest with its axis horizontal on an inclined plane which makes a small angle θ with the horizontal (Figure 1.2). Assume that the surfaces of the prism are slightly concave so that the prism only touches the plane at its edges. The effect of this concavity on the moment of inertia can be ignored. The prism is now displaced from rest and starts an uneven rolling down the plane. Assume that friction prevents any sliding and that the prism does not lose contact with the plane. The angular velocity just before a given edge hits the plane is ω_i while ω_f is the angular velocity immediately after the impact.

Show that we may write

$$\omega_f = s\omega_i \quad (1.3)$$

and write the value of the coefficient s on the answer sheet.

¹Authors: Leó Kristjánsson and Thorsteinn Vilhjálmsson

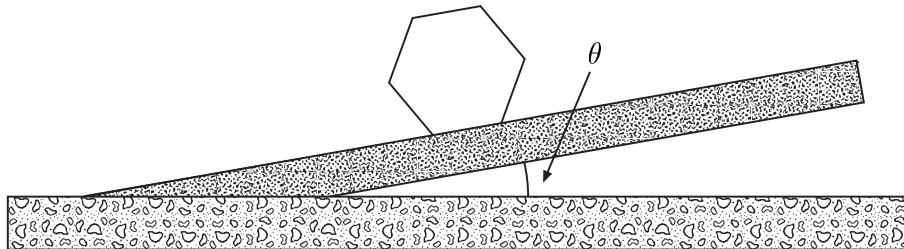

Figure 1.2: A hexagonal prism lying on an inclined plane.

- b) (1 point) The kinetic energy of the prism just before and after impact is similarly K_i and K_f .

Show that we may write

$$K_f = rK_i \quad (1.4)$$

and write the value of the coefficient r on the answer sheet.

- c) (1.5 points) For the next impact to occur K_i must exceed a minimum value $K_{i,min}$ which may be written in the form

$$K_{i,min} = \delta Mga \quad (1.5)$$

where $g = 9.81 \text{ m/s}^2$ is the acceleration of gravity.

Find the coefficient δ in terms of the slope angle θ and the coefficient r . Write your answer on the answer sheet. (Use the algebraic symbol r , not its value).

- d) (2 points) If the condition of part (c) is satisfied, the kinetic energy K_i will approach a fixed value $K_{i,0}$ as the prism rolls down the incline.

Given that the limit exists, show that $K_{i,0}$ may be written as:

$$K_{i,0} = \kappa Mga \quad (1.6)$$

and write the coefficient κ in terms of θ and r on the answer sheet.

- e) (2 points) Calculate, to within 0.1° , the minimum slope angle θ_0 , for which the uneven rolling, once started, will continue indefinitely. Write your numerical answer on the answer sheet.

1.2 Solution

a)

Solution Method 1

At the impact the prism starts rotating about a new axis, i.e. the edge which just hit the plane. The force from the plane has no torque about this axis, so that the angular momentum about the edge is conserved during the brief interval of impact. The linear

momentum of the prism as a whole has the same direction as the velocity of the center of mass ($\vec{P} = M \vec{v}_C$ where the subscript C refers to the center of mass), and this direction is easy to follow when we know the axis of rotation at a given time. Just before impact \vec{P} is directed 30° downwards relative to the plane, but will after impact point 30° upwards from the plane, see Figure 1.3.

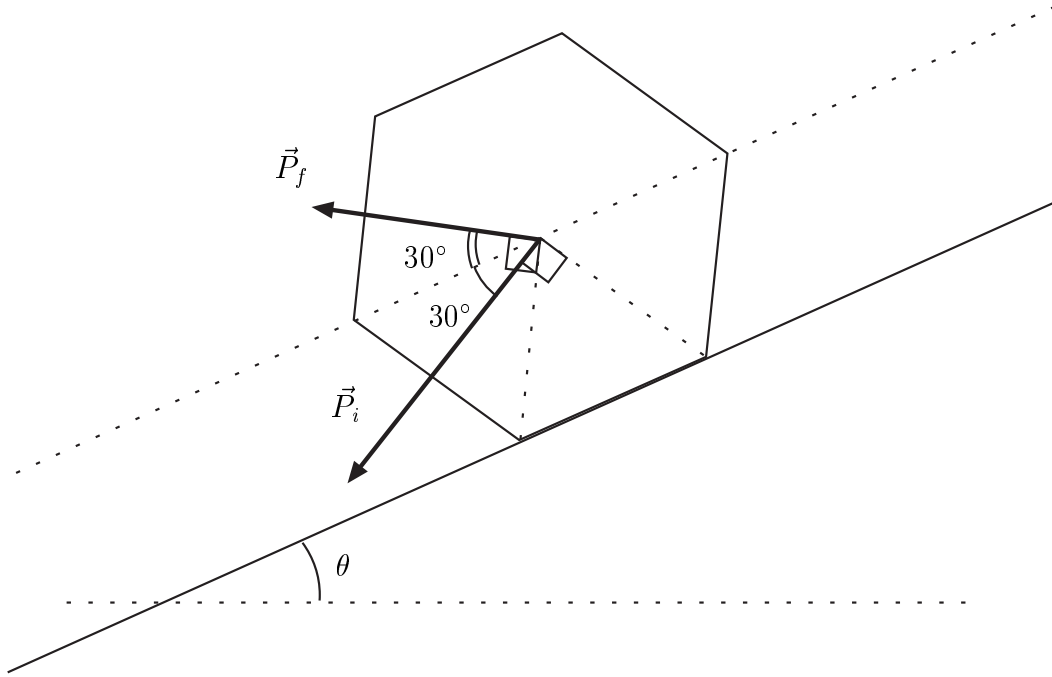

Figure 1.3: *The linear momentum of the prism as a whole, before and after impact.*

To find the angular momentum about the edge of impact just before the impact we use the equation relating angular momentum \vec{L} about an arbitrary axis to the angular momentum \vec{L}_C about an axis through the center of mass parallel to the first one:

$$\vec{L} = \vec{L}_C + M \vec{r}_C \times \vec{v}_C \quad (1.7)$$

where the subscript C refers to the center of mass. Here, this is applied to an axis at the point of impact so that \vec{r}_C is the vector from that point to the center of mass (Figure 1.3). The vectors on the right hand side of equation (1.7) both have the same direction. Hence we get for the quantities just before impact²

$$|\vec{r}_C \times \vec{v}_{Ci}| = r_C v_{Ci} \sin 30^\circ = a^2 \omega_i / 2 \quad (1.8)$$

$$L_i = I \omega_i + \frac{1}{2} M a^2 \omega_i = \left(\frac{5}{12} + \frac{1}{2} \right) M a^2 \omega_i = \frac{11}{12} M a^2 \omega_i \quad (1.9)$$

On the other hand, angular momentum about the edge just after impact is, from equation (1.2):³

²This may also be done by using Steiner's theorem twice, going from the previous axis of impact to the center of mass and from there to the new axis of impact.

³Alternatively:

$$L_f = I'\omega_f = \frac{17}{12}Ma^2\omega_f \quad (1.10)$$

where the subscript f always refers to the situation just after impact. We may notice that the difference comes about because of the different directions of \vec{v}_{Ci} and \vec{v}_{Cf} . Now, when we state the conservation of angular momentum, $L_i = L_f$, we obtain a relation between the angular velocities as follows:

$$\omega_f = \frac{11/12}{17/12} \omega_i = \frac{11}{17} \omega_i \quad (1.11)$$

We thus get:

$$\mathbf{s} = \mathbf{11/17} \quad (1.12)$$

We may note that s is independent of a , ω_i , and θ .

Solution Method 2

On impact the prism receives an impulse \vec{P} [N · s] from the plane at the edge where the impact occurs. There is no reaction at the edge which is leaving the plane. The impulse has a component P_{\parallel} parallel to the inclined plane (positive upwards along the incline in Figure 1.3 and a component P_{\perp} perpendicular to the plane (positive upwards from the plane in the same figure).

We can set up three equations with the three unknowns P_{\parallel} , P_{\perp} and the ratio $s = \frac{\omega_f}{\omega_i}$. The quantity P_{\parallel} is the change in the parallel component of the linear momentum of the prism and P_{\perp} is the corresponding change in perpendicular linear momentum. Thus:

$$P_{\parallel} = M(\omega_i - \omega_f)a \cdot \frac{\sqrt{3}}{2} \quad (1.13)$$

$$P_{\perp} = M(\omega_i + \omega_f)a \cdot \frac{1}{2}. \quad (1.14)$$

We finally have:

$$P_{\perp}a\frac{1}{2} - P_{\parallel}a\frac{\sqrt{3}}{2} = I(\omega_i - \omega_f) \quad (1.15)$$

since the right hand side is the change in angular momentum about the center of mass. Equations (1.13), (1.14) and (1.15) can now be solved for the ratio $s = \frac{\omega_f}{\omega_i}$ giving, of course, the same result as before.

$$\begin{aligned} L_f &= I\omega_f + M|\vec{r}_C \times \vec{v}_{Cf}| = I\omega_f + Ma^2\omega_f \sin 90^\circ \\ &= \left(\frac{5}{12} + 1\right)Ma^2\omega_f = \frac{17}{12}Ma^2\omega_f \end{aligned}$$

b)

The linear speed of the center of mass just before impact is $a\omega_i$ and just after impact it is $a\omega_f$. We know that we can always write the kinetic energy of a rotating rigid body as a sum of „internal“ and „external“ kinetic energy:

$$K_{tot} = \frac{1}{2} I \omega^2 + \frac{1}{2} M v_C^2 \quad (1.16)$$

From this we see that in our case the kinetic energy K_{tot} is proportional to ω^2 both before and after impact so that we get

$$K_f = r K_i = \left(\frac{11}{17}\right)^2 K_i = \frac{121}{289} K_i \quad (1.17)$$

so

$$r = 121/289 \approx 0.419 \quad (1.18)$$

c)

The kinetic energy K_f after the impact must be sufficient to lift the center of mass to its highest position, straight above the point of contact. The angle through which \vec{r}_C moves for this is

$$x = \frac{\alpha}{2} - \theta \quad (1.19)$$

where $\alpha = 60^\circ$ is the top angle of the triangles meeting at the center of the polygon.⁴ The energy for this lifting of the center of mass is

$$E_0 = Mga(1 - \cos x) = Mga(1 - \cos(30^\circ - \theta)) \quad (1.20)$$

and we get the condition

$$K_f = rK_i > E_0 = Mga(1 - \cos(30^\circ - \theta)) \quad (1.21)$$

thus

$$\delta = \frac{1}{r} (1 - \cos(30^\circ - \theta)) \quad (1.22)$$

(Note that $\cos(30^\circ - \theta) = \frac{\sqrt{3}}{2} \cos \theta + \frac{1}{2} \sin \theta$).

d)

Let $K_{i,n}$ and $K_{f,n}$ be the kinetic energies just before and just after the n th impact. We have shown that we have the relation

⁴In the general case $\alpha = 2\pi/N$.

$$K_{f,n} = r K_{i,n} \quad (1.23)$$

where $r = \frac{121}{289}$ for a hexagonal prism. Between subsequent impacts the height of the center of mass of the prism decreases by $a \sin \theta$ and its kinetic energy increases for this reason by

$$\Delta = Mga \sin \theta \quad (1.24)$$

We therefore have

$$K_{i,n+1} = rK_{i,n} + \Delta. \quad (1.25)$$

One does not have to write out the complete expression $K_{i,n}$ as a function of $K_{i,1}$ and n to find the limit. This would actually be a proof that the limit exists (see below) but this is given in the problem text. Hence one can make $K_{i,n+1} \approx K_{i,n}$ arbitrarily accurate for sufficiently large n . The limit $K_{i,0}$ must thus satisfy the iterative formula, i.e.

$$K_{i,0} = rK_{i,0} + \Delta \quad (1.26)$$

yielding the solution

$$K_{i,0} = \frac{\Delta}{1-r}. \quad (1.27)$$

i.e.

$$\kappa = \frac{\sin \theta}{1-r} \quad (1.28)$$

We can also solve the problem explicitly by writing out the full expressions:

$$K_{i,2} = r K_{i,1} + \Delta \quad (1.29)$$

$$K_{i,3} = r K_{i,2} + \Delta = r^2 K_{i,1} + (1+r)\Delta \quad (1.30)$$

...

$$K_{i,n} = r^{n-1} K_{i,1} + (1+r+\dots+r^{n-2})\Delta \quad (1.31)$$

$$= r^{n-1} K_{i,1} + \frac{1-r^{n-1}}{1-r}\Delta \quad (1.32)$$

In the limit of $n \rightarrow \infty$ we get

$$K_{i,n} \rightarrow K_{i,0} = \frac{\Delta}{1-r} \quad (1.33)$$

which is, of course, the same result as before.

If we calculate the change in kinetic energy through a whole cycle, i.e. from just before impact number n until just before impact $n+1$ we get

$$\Delta K_{i,n} = K_{i,n+1} - K_{i,n} = (r-1)r^{n-1}K_{i,1} + r^{n-1}\Delta \quad (1.34)$$

$$= r^{n-1}(\Delta - (1-r)K_{i,1}) \quad (1.35)$$

This is positive if the initial value $K_{i,1} < K_{i,0}$ so that $K_{i,n}$ will then increase up to the limit value $K_{i,0}$. If, on the other hand, $K_{i,1} > K_{i,0}$, the kinetic energy $K_{i,n}$ just before impact will decrease down to the limit $K_{i,0}$.

All of this may remind you of motion with friction which increases with speed. Mathematically speaking, the main difference is that we here are dealing with difference equations instead of differential equations.

e)

For indefinite continuation the limit value of K_i in part (d) must be larger than the minimum value for continuation found in part (c):

$$\frac{1}{1-r}\Delta = \frac{1}{1-r}Mga \sin \theta > Mga (1 - \cos(30^\circ - \theta)) / r \quad (1.36)$$

We put $A = \frac{r}{1-r} = \frac{121}{168}$:

$$A \sin \theta > 1 - \cos 30^\circ \cos \theta - \sin 30^\circ \sin \theta \quad (1.37)$$

$$(A + 1/2) \sin \theta + \sqrt{3}/2 \cos \theta > 1 \quad (1.38)$$

To solve this we define⁵

$$u = \arccos \left(\frac{A + 1/2}{\sqrt{(A + 1/2)^2 + 3/4}} \right) \approx 35.36^\circ \quad (1.39)$$

and obtain

$$\cos u \sin \theta + \sin u \cos \theta > 1/\sqrt{(A + 1/2)^2 + 3/4} \quad (1.40)$$

$$\sin(u + \theta) > 1/\sqrt{(A + 1/2)^2 + 3/4} \quad (1.41)$$

$$\theta > \arcsin\{1/\sqrt{(A + 1/2)^2 + 3/4}\} - u \approx 41.94^\circ - 35.36^\circ = 6.58^\circ \quad (1.42)$$

That is

$$\theta_0 \approx 6.58^\circ \quad (1.43)$$

If $\theta > \theta_0$ and the kinetic energy before the first impact is sufficient according to part (c), we will, under the assumptions made, get an indefinite “rolling”.

⁵You can of course solve any of the inequalities in a purely numerical way, e.g. by progressive guessing or by using the approximations $\sin \phi \approx \phi$ and $\cos \phi \approx 1 - \phi^2/2$.

1.3 Grading scheme

Part 2(a)	
Answer: $s = \omega_f/\omega_i = 11/17$, equation (1.12)	3.5
Part 2(b)	
Answer: $r = K_f/K_i = s^2 = 121/289$, equation (1.18)	1.0
Part 2(c)	
Answer: $K_{i,min}$ by δ , equation (1.22)	1.5
Part 2(d)	
Answer: Limit $K_{i,0}$ by $\kappa = \sin \theta/(1 - r)$, equation (1.28)	2.0
Part 2(e)	
Answer: Minimum angle $\theta_0 = 6.58^\circ$, equation (1.43)	2.0

2 Water under an ice cap⁶

2.1 Problem text

An ice cap is a thick sheet of ice (up to a few km in thickness) resting on the ground below and extending horizontally over tens or hundreds of km. In this problem we consider the melting of ice and the behavior of water under a temperate ice cap, i.e. an ice cap at the melting point. We may assume that under such conditions the ice causes pressure variations as a viscous fluid, but deforms in a brittle fashion, principally by vertical movement. For the purposes of this problem the following information is given.

Density of water:	$\rho_w = 1.000 \cdot 10^3 \text{ kg/m}^3$
Density of ice:	$\rho_i = 0.917 \cdot 10^3 \text{ kg/m}^3$
Specific heat of ice:	$c_i = 2.1 \cdot 10^3 \text{ J/(kg } ^\circ\text{C)}$
Specific latent heat of ice:	$L_i = 3.4 \cdot 10^5 \text{ J/kg}$
Density of rock and magma:	$\rho_r = 2.9 \cdot 10^3 \text{ kg/m}^3$
Specific heat of rock and magma:	$c_r = 700 \text{ J/(kg } ^\circ\text{C)}$
Specific latent heat of rock and magma:	$L_r = 4.2 \cdot 10^5 \text{ J/kg}$
Average outward heat flow through the surface of the earth:	$J_Q = 0.06 \text{ W/m}^2$
Melting point of ice:	$T_0 = 0^\circ\text{C, constant}$

a) (0.5 points) Consider a thick ice cap at a location of average heat flow from the interior of the earth. Using the data from the table, calculate the thickness d of the ice layer melted every year and write your answer in the designated box on the answer sheet.

b) (3.5 points) Consider now the upper surface of an ice cap. The ground below the ice cap has a slope angle α . The upper surface of the cap slopes by an angle β as shown in Figure 2.1. The vertical thickness of the ice at $x = 0$ is h_0 . Hence the lower and upper surfaces of the ice cap can be described by the equations

$$y_1 = x \tan \alpha, \quad y_2 = h_0 + x \tan \beta \quad (2.1)$$

Derive an expression for the pressure p at the bottom of the ice cap as a function of the horizontal coordinate x and write it on the answer sheet.

Formulate mathematically a condition between β and α , so that water in a layer between the ice cap and the ground will flow in neither direction. Show that the condition is of the form $\tan \beta = s \tan \alpha$. Find the coefficient s and write the result in a symbolic form on the answer sheet.

The line $y_1 = 0.8 x$ in Figure 2.2 shows the surface of the earth below an ice cap. The vertical thickness h_0 at $x = 0$ is 2 km. Assume that water at the bottom is in equilibrium.

On a graph answer sheet draw the line y_1 and add a line y_2 showing the upper surface of the ice. Indicate on the figure which line is which.

⁶Authors: Gudni Axelsson and Thorsteinn Vilhjálmsson

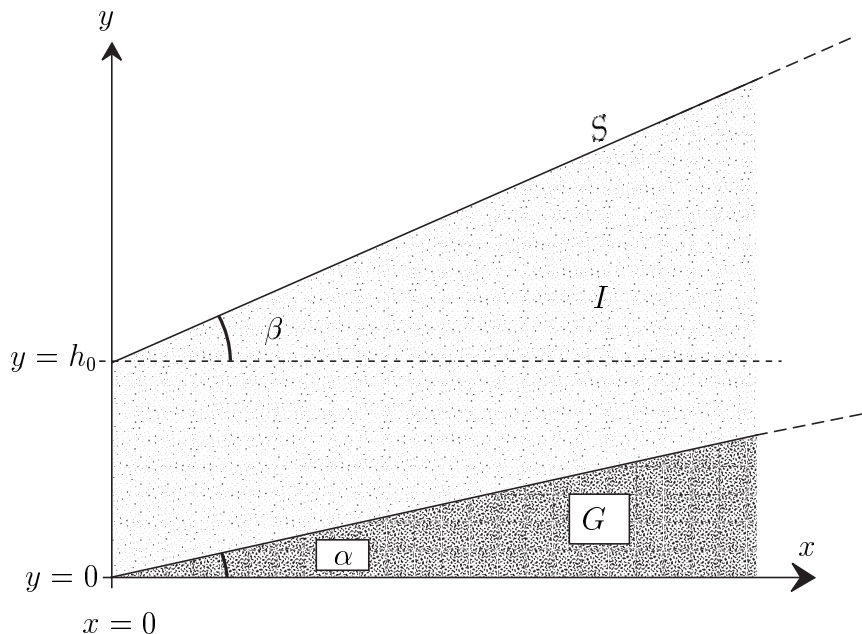

Figure 2.1: *Cross section of an ice cap with a plane surface resting on an inclined plane ground. S : surface, G : ground, I : ice cap.*

c) (1 point) Within a large ice sheet on horizontal ground and originally of constant thickness $D = 2.0$ km, a conical body of water of height $H = 1.0$ km and radius $r = 1.0$ km is formed rather suddenly by melting of the ice (Figure 2.3). We assume that the remaining ice adapts to this by vertical motion only.

Show analytically on a blank answer sheet and pictorially on a graph answer sheet, the shape of the surface of the ice cap after the water cone has formed and hydrostatic equilibrium has been reached.

d) (5 points) In its annual expedition an international group of scientists explores a temperate ice cap in Antarctica. The area is normally a wide plateau but this time they find a deep crater-like depression, formed like a top-down cone with a depth h of 100 m and a radius r of 500 m (Figure 2.4). The thickness of the ice in the area is 2000 m.

After a discussion the scientists conclude that most probably there was a minor volcanic eruption below the ice cap. A small amount of magma (molten rock) intruded at the bottom of the ice cap, solidified and cooled, melting a certain volume of ice. The scientists try as follows to estimate the volume of the intrusion and get an idea of what became of the melt water.

Assume that the ice only moved vertically. Also assume that the magma was completely molten and at 1200°C at the start. For simplicity, assume further that the intrusion had the form of a cone with a circular base vertically below the conical depression in the surface. The time for the rising of the magma was short relative to the time for the exchange of heat in the process. The heat flow is assumed to have been primarily vertical such that the volume melted from the ice at any time is bounded by a conical surface centered above the center of the magma intrusion.

Given these assumptions the melting of the ice takes place in two steps. At first the water is not in pressure equilibrium at the surface of the magma and hence flows away. The water flowing away can be assumed to have a temperature of 0°C . Subsequently,

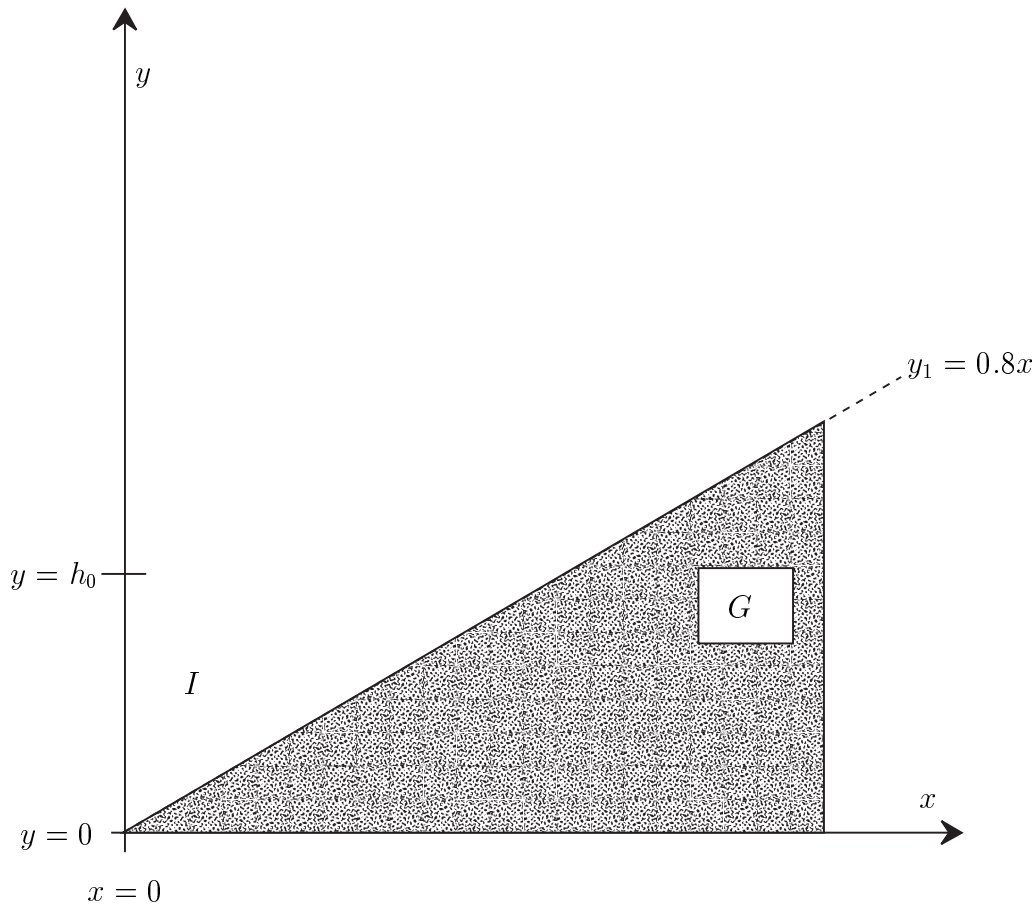

Figure 2.2: *Cross section of a temperate ice cap resting on an inclined ground with water at the bottom in equilibrium. G: ground, I: ice cap.*

hydrostatic equilibrium is reached and the water accumulates above the intrusion instead of flowing away.

When thermal equilibrium has been reached, you are asked to determine the following quantities. Write the answers on the answer sheet.

1. The height H of the top of the water cone formed under the ice cap, relative to the original bottom of the ice cap.
2. The height h_1 of the intrusion.
3. The total mass m_{tot} of the water produced and the mass m' of water that flows away.

Plot on a graph answer sheet, to scale, the shapes of the rock intrusion and of the body of water remaining. Use the coordinate system suggested in Figure 2.4.

2.2 Solution

a)

Based on the conservation of energy we have

$$J_Q \cdot 1 \text{ year} = L_i \rho_i d \quad (2.2)$$

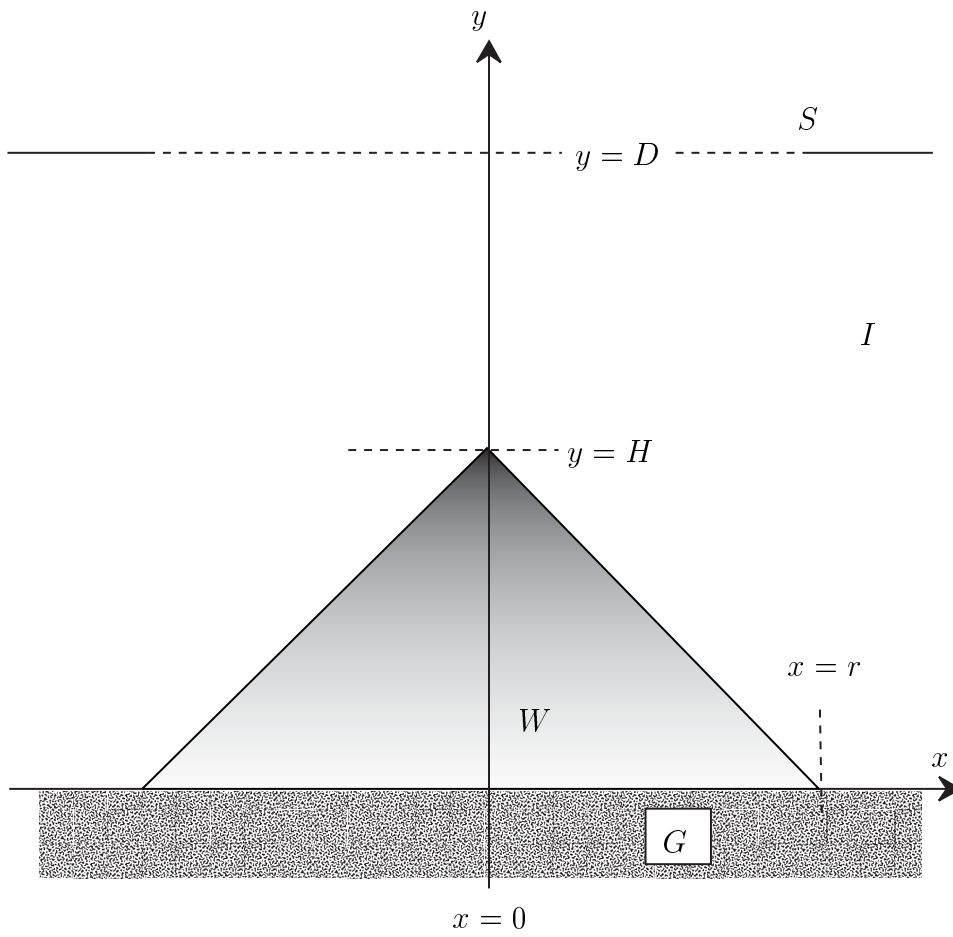

Figure 2.3: A vertical section through the mid-plane of a water cone inside an ice cap. *S*: surface, *W*: water, *G*: ground, *I*: ice cap.

$$\mathbf{d} = \frac{J_Q \cdot 1 \text{ year}}{L_i \rho_i} = \frac{0.06 \text{ J s}^{-1} \text{ m}^{-2} \cdot 365.25 \cdot 24 \cdot 60 \cdot 60 \text{ s}}{3.4 \cdot 10^5 \text{ J/kg} \cdot 917 \text{ kg/m}^3} = \mathbf{6.1 \cdot 10^{-3} \text{ m}} \quad (2.3)$$

b)

Let p_a be the atmospheric pressure, taken to be constant. At a depth z inside the ice cap the pressure is given by:

$$p = \rho_i g z + p_a \quad (2.4)$$

Therefore, at the bottom of the ice cap, where $z = y_2 - y_1$:

$$\mathbf{p} = \rho_i g (y_2 - y_1) + p_a \quad (2.5)$$

$$= \rho_i g x (\tan \beta - \tan \alpha) + \rho_i g h_0 + p_a \quad (2.6)$$

For water not to move at the base of the ice cap the pressure must be hydrostatic (trivial, but can be seen from Bernoulli's equation), i.e.

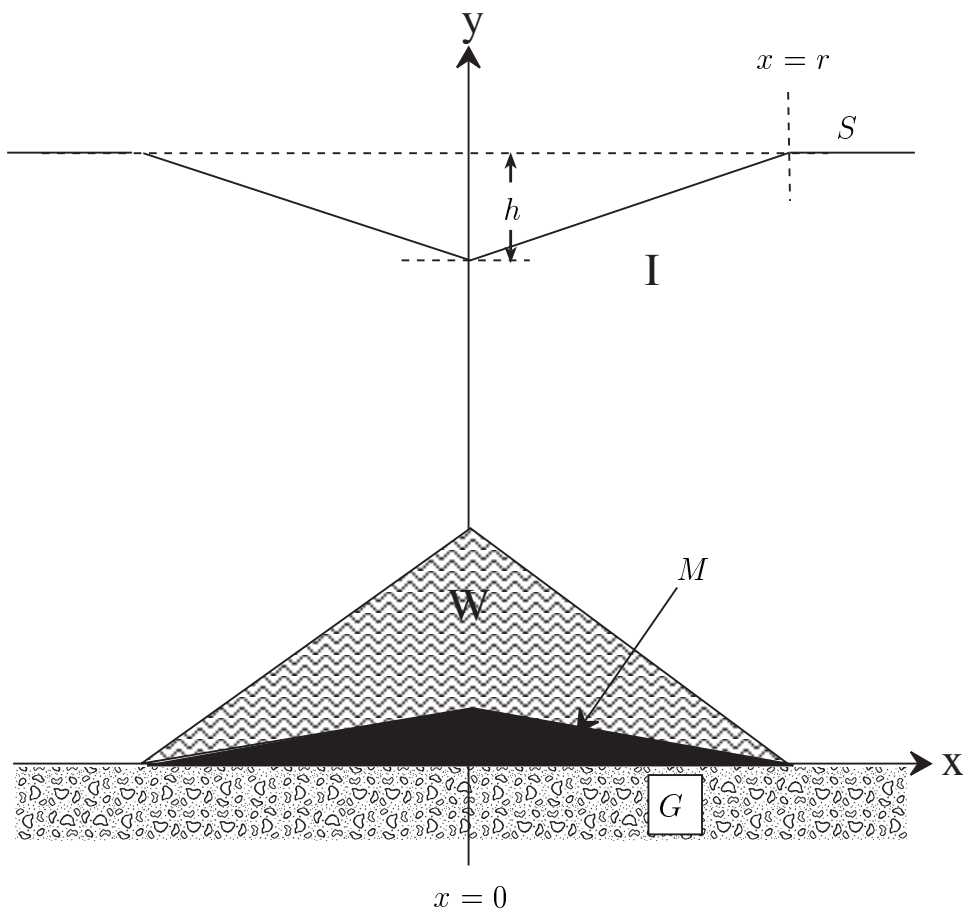

Figure 2.4: A vertical and central cross section of a conical depression in a temperate ice cap. *S*: surface, *G*: ground, *I*: ice cap, *M*: rock/magma intrusion, *W*: water. Note that the figure is NOT drawn to scale.

$$p = \text{constant} - \rho_w g y_1 \quad (2.7)$$

$$= \text{constant} - \rho_w g x \tan \alpha \quad (2.8)$$

Therefore

$$\rho_i g x (\tan \beta - \tan \alpha) = -\rho_w g x \tan \alpha \quad (2.9)$$

leading to

$$\tan \beta = -\frac{\rho_w - \rho_i}{\rho_i} \tan \alpha = -\frac{\Delta \rho}{\rho_i} \tan \alpha \approx -0.091 \tan \alpha \quad (2.10)$$

$$s = -\Delta \rho / \rho_i = -0.091 \quad (2.11)$$

$$(2.12)$$

where the minus-sign is significant.

This can also be seen in various ways by looking at a mass element of water at the bottom of the ice and demanding equilibrium. – We now proceed with the solution.

With $\tan \alpha = 0.8$, we get $\tan \beta = -0.073$ and

$$\mathbf{y}_2 = \mathbf{2\ km} - \mathbf{0.073\ x} \quad (2.13)$$

The students are supposed to draw this line on a graph.

c)

Since the ice adapts by vertical motion only we see that the conical depression at the surface will have the same radius of 1.0 km as the intrusion. According to (b) it will have a depth of

$$h = |r \tan \beta| = \frac{\Delta \rho}{\rho_i} r \tan \alpha \quad (2.14)$$

$$= \frac{\Delta \rho}{\rho_i} H \quad (2.15)$$

$$= 0.091 \cdot 1\ \text{km} = 91\ \text{m}. \quad (2.16)$$

The students are supposed to show this result as a graph.

d)

The volume of a circular cone is $V = \frac{1}{3}\pi r^2 h$. We assume that the height of the intrusion is h_1 . We may say that it firstly melts an ice cone of its own volume $V_1 = \frac{1}{3}\pi r^2 h_1$. Pressure equilibrium has not yet been reached. Hence the water will flow away and the ice will keep contact with the face of the intrusion making the upper surface of the ice horizontal again. The intrusion then melts a volume equivalent to a cone of height $h_2 = \frac{\Delta \rho}{\rho_i} h_1$ whereupon pressure equilibrium has been reached (following part (c)). During this second phase the melted water will also flow away. Assuming that the intrusion still has not cooled down to 0°C the intrusion will further melt a volume equivalent to a cone of height h_3 , its water accumulating in place, forming a cone of height $h'_3 = \frac{\rho_i}{\rho_w} h_3$ relative to the top of the intrusion. The total height of the ice cone melted is

$$h_{tot} = h_1 + h_2 + h_3 \quad (2.17)$$

The depth of the depression at the surface will be given by

$$h = \frac{\Delta \rho}{\rho_i} (h_1 + h'_3) \quad (2.18)$$

which is most easily seen by considering pressure equilibrium in the final situation (again following part (c)). Thus, the requested height of the top of the water cone is

$$\mathbf{H} = h_1 + h'_3 = \frac{\rho_i}{\Delta \rho} h = \mathbf{1.1 \times 10^3\ m} \quad (2.19)$$

The heat balance gives

$$\frac{1}{3} \pi r^2 \{ \rho_r h_1 (L_r + c_r \Delta T) - \rho_i L_i h_{tot} \} = 0 \quad (2.20)$$

where $\Delta T = 1200^\circ\text{C}$ is the change in temperature of the rock intrusion. Following equation (2.17) and using the facts that $h_2 = \frac{\Delta\rho}{\rho_i}h_1$ and $h_3 = \frac{\rho_w}{\rho_i}h'_3$ we obtain

$$h_{tot} = h_1 + \frac{\Delta\rho}{\rho_i}h_1 + \frac{\rho_w}{\rho_i}h'_3 = \frac{\rho_w}{\rho_i}(h_1 + h'_3) \quad (2.21)$$

Therefore (using equation (2.19))

$$h_{tot} = \frac{\rho_w}{\rho_i}(h_1 + h'_3) = \frac{\rho_w}{\rho_i}H = \frac{\rho_w}{\Delta\rho}h = 1.20 \cdot 10^3\text{m} \quad (2.22)$$

This implies that the cone does not reach the surface of the ice cap. Inserting the result into the equation (2.20) we can solve for h_1 :

$$\rho_r h_1 (L_r + c_r \Delta T) = \frac{\rho_i \rho_w L_i h}{\Delta\rho} \quad (2.23)$$

$$\mathbf{h_1} = \frac{\rho_i \rho_w L_i h}{\Delta\rho \rho_r (L_r + c_r \Delta T)} \quad (2.24)$$

$$= \mathbf{103\text{ m}} \quad (2.25)$$

The total mass of water formed is of course equal to the mass of the ice melted and is

$$\mathbf{m_{tot} = \rho_i (1/3) \pi r^2 h_{tot} = 2.9 \cdot 10^{11}\text{ kg}} \quad (2.26)$$

The mass of the water which flows away is

$$\mathbf{m' = \frac{h_1 + h_2}{h_{tot}} m_{tot} = \frac{\rho_w h_1}{\rho_i h_{tot}} m_{tot} = 2.7 \cdot 10^{10}\text{ kg}} \quad (2.27)$$

The students are finally expected to plot the shapes of the rock intrusion and the water body.

2.3 Grading scheme

2(a)	
Answer: equation (2.3), $d = 6.1 \cdot 10^{-3}\text{ m}$	0.5
2(b)	
Answer i): equation (2.6): $p = \rho_i g x (\tan \beta - \tan \alpha) + \rho_i g h_0 + p_a$	1.0
Answer ii): equation (2.10): $s = -\frac{\rho_w - \rho_i}{\rho_i} = -\frac{\Delta\rho}{\rho_i}$	2.0
Answer iii): Graph based on equation (2.13)	0.5
2(c)	
Answer: Depth, radius and graph, $r = 1000\text{ m}$, $h = 91\text{ m}$	1.0
2(d)	
Answer i): Height of water cone as in (2.19): $H = 1.1 \cdot 10^3\text{ m}$	2.0
Answer ii): Height of intrusion as in (2.25): $h_1 = 103\text{ m}$	1.0
Answer iii): Total mass of melt water as in (2.26): $m_{tot} = 2.9 \cdot 10^{11}\text{ kg}$	0.5
Answer iv): Mass of water flowing away as in (2.27): $m' = 2.7 \cdot 10^{10}\text{ kg}$	1.0
Answer v): Graph	0.5

3 Faster than light?⁷

3.1 Problem text

In this problem we analyze and interpret measurements made in 1994 on radio wave emission from a compound source within our galaxy.

The receiver was tuned to a broad band of radio waves of wavelengths of several centimeters. Figure 3.1 shows a series of images recorded at different times. The contours indicate constant radiation strength in much the same way as altitude contours on a geographical map. In the figure the two maxima are interpreted as showing two objects moving away from a common center shown by crosses in the images. (The center, which is assumed to be fixed in space, is also a strong radiation emitter but mainly at other wavelengths). The measurements conducted on the various dates were made at the same time of day.

The scale of the figure is given by a line segment showing one arc second (as). (1 as = 1/3600 of a degree). The distance to the celestial body at the center of the figure, indicated by crosses, is estimated to be $R = 12.5$ kpc. A kiloparsec (kpc) equals $3.09 \cdot 10^{19}$ m. The speed of light is $c = 3.00 \cdot 10^8$ m/s. Error calculations are not required in the solution.

a) (2 points) We denote the angular positions of the two ejected radio emitters, relative to the common center, by $\theta_1(t)$ and $\theta_2(t)$, where the subscripts 1 and 2 refer to the left and right hand ones, respectively, and t is the time of observation. The angular speeds, as seen from the Earth, are ω_1 and ω_2 . The corresponding apparent transverse linear speeds of the two sources are denoted by $v'_{1,\perp}$ and $v'_{2,\perp}$.

Using Figure 3.1, make a graph to find the numerical values of ω_1 and ω_2 in milli-arc-seconds per day (mas/d). Also determine the numerical values of $v'_{1,\perp}$ and $v'_{2,\perp}$, and write all answers on the answer sheet. (You may be puzzled by some of the results).

b) (3 points) In order to resolve the puzzle arising in part (a), consider a light-source moving with velocity \vec{v} at an angle ϕ ($0 \leq \phi \leq \pi$) to the direction towards a distant observer O (Figure 3.2). The speed may be written as $v = \beta c$, where c is the speed of light. The distance to the source, as measured by the observer, is R . The angular speed of the source, as seen from the observer, is ω , and the apparent linear speed perpendicular to the line of sight is v'_{\perp} .

Find ω and v'_{\perp} in terms of β , R and ϕ and write your answer on the answer sheet.

c) (1 point) We assume that the two ejected objects, described in the introduction and in part (a), are moving in opposite directions with equal speeds $v = \beta c$. Then the results of part (b) make it possible to calculate β and ϕ from the angular speeds ω_1 and ω_2 and the distance R . Here ϕ is the angle defined in part (b), for the left hand object, corresponding to subscript 1 in part (a).

Derive formulas for β and ϕ in terms of known quantities and determine their numerical values from the data in part (a). Write your answers in the designated fields on the answer sheet.

d) (2 points) In the one-body situation of part (b), find the condition for the apparent perpendicular speed v'_{\perp} to be larger than the speed of light c .

⁷Authors: Einar Gudmundsson, Knútur Árnason and Thorsteinn Vilhjálmsson

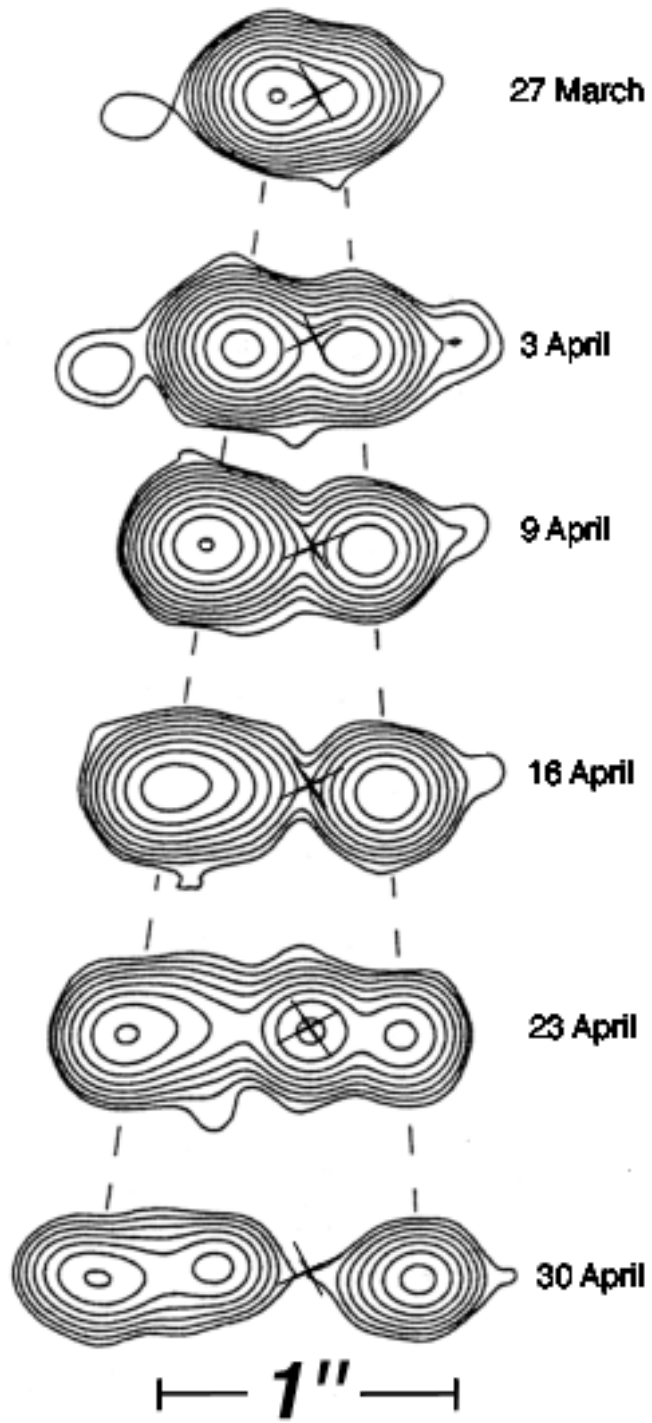

Figure 3.1: *Radio emission from a source in our galaxy.*

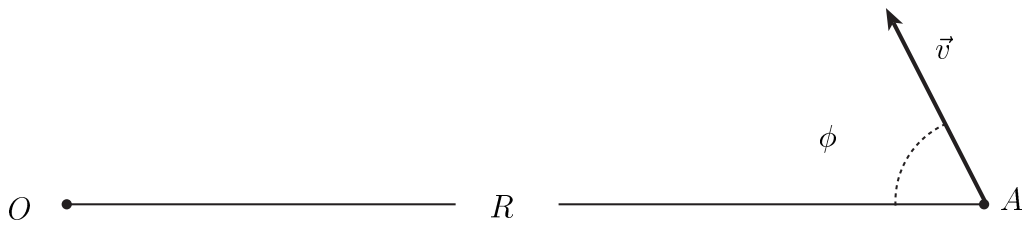

Figure 3.2: The observer is at O and the original position of the light source is at A . The velocity vector is \vec{v} .

Write the condition in the form $\beta > f(\phi)$ and provide an analytic expression for the function f on the answer sheet.

Draw on the graph answer sheet the physically relevant region of the (β, ϕ) -plane. Show by shading in which part of this region the condition $v'_\perp > c$ holds.

e) (1 point) Still in the one-body situation of part (b), find an expression for the maximum value $(v'_\perp)_{max}$ of the apparent perpendicular speed v'_\perp for a given β and write it in the designated field on the answer sheet. Note that this speed increases without limit when $\beta \rightarrow 1$.

f) (1 point) The estimate for R given in the introduction is not very reliable. Scientists have therefore started speculating on a better and more direct method for determining R . One idea for this goes as follows. Assume that we can identify and measure the Doppler shifted wavelengths λ_1 and λ_2 of radiation from the two ejected objects, corresponding to the same known original wavelength λ_0 in the rest frames of the objects.

Starting from the equations for the relativistic Doppler shift, $\lambda = \lambda_0(1 - \beta \cos \phi)(1 - \beta^2)^{-1/2}$, and assuming, as before, that both objects have the same speed, v , show that the unknown $\beta = v/c$ can be expressed in terms of λ_0 , λ_1 , and λ_2 as

$$\beta = \sqrt{1 - \frac{\alpha \lambda_0^2}{(\lambda_1 + \lambda_2)^2}}. \quad (3.1)$$

Write the numerical value of the coefficient α in the designated field on the answer sheet.

You may note that this means that the suggested wavelength measurements will in practice provide a new estimate of the distance.

3.2 Solution

a) On Figure 3.1 we mark the centers of the sources as neatly as we can. Let $\theta_1(t)$ be the angular distance of the left center from the cross as a function of time and $\theta_2(t)$ the angular distance of the right center. We measure these quantities on the figure at the given times by a ruler and convert to arcseconds according to the given scale. This results in the following numerical data:

time [days]	θ_1 [as]	θ_2 [as]
0	0.139	0.076
7	0.253	0.139
13	0.354	0.190
20	0.468	0.253
27	0.601	0.316
34	0.709	0.367

The uncertainty in the readings by the ruler is estimated to be ± 0.5 mm, resulting in the uncertainty of ± 0.013 as in the θ values. We plot the data in Figure 3.3.

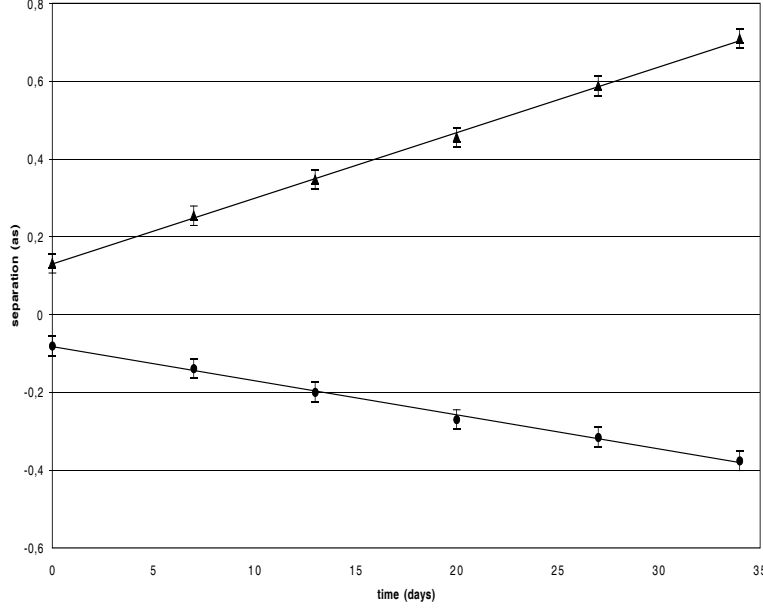

Figure 3.3: *The angular distances θ_1 and θ_2 (in as) as functions of the time in days.*

Fitting straight lines through the data results in:

$$\omega_1 = d\theta_1/dt = (17.0 \pm 1.0) \text{ mas/day} = 9.54 \cdot 10^{-13} \text{ rad/s} \quad (3.2)$$

$$\omega_2 = d\theta_2/dt = (8.7 \pm 1.0) \text{ mas/day} = 4.88 \cdot 10^{-13} \text{ rad/s} \quad (3.3)$$

$$v'_{1,\perp} = \omega_1 R = 9.54 \cdot 10^{-13} \cdot 12.5 \cdot 3.09 \cdot 10^{19} \quad (3.4)$$

$$= 3.68 \cdot 10^8 \text{ m/s} \approx (1.23 \pm 0.07) c \quad (3.5)$$

$$v'_{2,\perp} = 1.89 \cdot 10^8 \text{ m/s} \approx (0.63 \pm 0.07) c \quad (3.6)$$

b) We consider the motion of the source during the time interval Δt from the point A to the point A' , see Figure 3.4.

We then have

$$\vec{r}_{AA'} = \vec{r}_{A'} - \vec{r}_A = \vec{v} \cdot \Delta t. \quad (3.7)$$

Now let $\Delta t'$ denote the difference in arrival times at O of the signals from A and A' . Due to the different distances to A and A' and the finite speed of light, c , we have

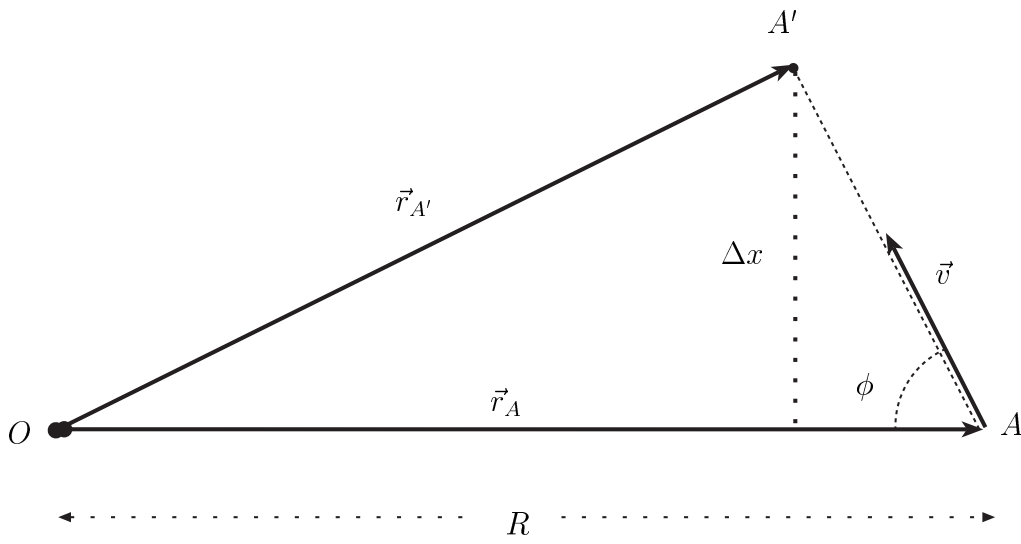

Figure 3.4: The observer is at O and the original position of the source is at A . The velocity vector is \vec{v} .

$$\Delta t' = \Delta t + (r_{A'} - r_A)/c . \quad (3.8)$$

For small Δt , such that $v \Delta t \ll r_A = R$, we have

$$r_{A'} - r_A \approx -v \Delta t \cos \phi \quad (3.9)$$

and hence

$$\Delta t' \approx \Delta t (1 - \beta \cos \phi) ; \beta = v/c . \quad (3.10)$$

This implies that an observer at O will find the apparent transverse speed of the source to be

$$\mathbf{v}'_{\perp} = \frac{\Delta x}{\Delta t'} = \frac{\Delta x}{\Delta t (1 - \beta \cos \phi)} = \frac{\mathbf{c}\beta \sin \phi}{\mathbf{1} - \beta \cos \phi} \quad (3.11)$$

where we have used that the real transverse speed in the reference frame of the observer is $v_{\perp} = \Delta x/\Delta t = c\beta \sin \phi$.

The angular speed observed at O is

$$\boldsymbol{\omega} = \frac{v'_{\perp}}{R} = \frac{\mathbf{c}\beta \sin \phi}{\mathbf{R} (1 - \beta \cos \phi)} \quad (3.12)$$

c) Figure 3.5 shows the situation in this case. Note the relations given in the caption. Taking $\phi = \phi_1$ we have $\sin \phi_2 = \sin \phi$ and $\cos \phi_2 = -\cos \phi$. Equation (3.12) then gives:

$$\omega_1 = \frac{\beta c \sin \phi}{R (1 - \beta \cos \phi)} \quad (3.13)$$

$$\omega_2 = \frac{\beta c \sin \phi}{R (1 + \beta \cos \phi)} . \quad (3.14)$$

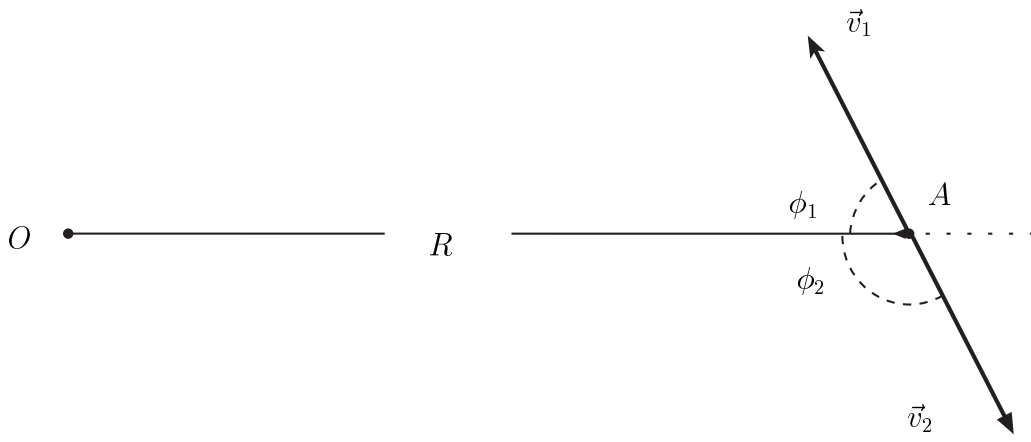

Figure 3.5: If the two objects have equal speeds but opposite velocities we have $v_1 = v_2 = v$, $\beta_1 = \beta_2 = \beta$ and $\phi_2 = \pi - \phi_1$.

The quantities ω_1 , ω_2 and R are given, but β and ϕ are to be determined as stated in the problem text. Simple algebra gives:

$$(1 - \beta \cos \phi) \omega_1 \omega_2 = \beta c \sin \phi \omega_2 / R \quad (3.15)$$

$$(1 + \beta \cos \phi) \omega_2 \omega_1 = \beta c \sin \phi \omega_1 / R . \quad (3.16)$$

Subtracting (3.15) from (3.16) gives:

$$2 \beta \cos \phi \omega_2 \omega_1 = \beta c \sin \phi (\omega_1 - \omega_2) / R \quad (3.17)$$

$$\tan \phi = \frac{2 R \omega_2 \omega_1}{c (\omega_1 - \omega_2)} \quad (3.18)$$

$$\phi = \arctan \left(\frac{2 R \omega_2 \omega_1}{c (\omega_1 - \omega_2)} \right) . \quad (3.19)$$

Dividing (3.15) by (3.16) gives β in terms of $\cos \phi$ and the known quantities ω_1 and ω_2 :

$$\omega_1 (1 - \beta \cos \phi) = \omega_2 (1 + \beta \cos \phi) \quad (3.20)$$

$$\beta = \frac{\omega_1 - \omega_2}{\cos \phi (\omega_1 + \omega_2)} . \quad (3.21)$$

Inserting the values of ω_1 and ω_2 from part (a) and the given values of R and c we get:

$$\phi = \arctan(2.57) = \mathbf{1.20 \text{ rad} = 68.8^\circ \pm 2^\circ} \quad (3.22)$$

$$\beta = \mathbf{0.892 \pm 0.08} \quad (3.23)$$

d) Equation (3.11) shows that the observer will find the apparent transverse speed to be larger than or equal to the speed of light if and only if:

$$\frac{\beta \sin \phi}{1 - \beta \cos \phi} \geq 1. \quad (3.24)$$

If $\beta < 1$ condition (3.24) is equivalent to:

$$\beta \sin \phi \geq 1 - \beta \cos \phi \quad (3.25)$$

$$\beta (\sin \phi + \cos \phi) \geq 1 \quad (3.26)$$

$$\beta \sqrt{2} \left(\sin \phi \cos \frac{\pi}{4} + \cos \phi \sin \frac{\pi}{4} \right) \geq 1 \quad (3.27)$$

$$\sin \left(\phi + \frac{\pi}{4} \right) \geq \frac{1}{\beta \sqrt{2}} \quad (3.28)$$

and hence (3.24) is satisfied if:

$$\beta > \mathbf{f}(\phi) = \left(\sqrt{2} \sin(\phi + \pi/4) \right)^{-1}. \quad (3.29)$$

The physically relevant region in the (β, ϕ) -plane is:

$$(\beta, \phi) \in [0, 1] \times [0, \pi]. \quad (3.30)$$

It is obvious that (3.24) can only be satisfied for $\phi \in [0, \pi/2]$ and (3.28) can only have a solution for ϕ if $\beta \geq 1/\sqrt{2}$.

We therefore take a closer look at the region

$$(\beta, \phi) \in [2^{-1/2}, 1] \times [0, \pi/2] \quad (3.31)$$

The mapping

$$(\beta, \phi) \mapsto \beta \sin \left(\phi + \frac{\pi}{4} \right) \quad (3.32)$$

is continuous in this region. It is therefore sufficient to look at the boundary of the region, defined by the equality sign in (3.28):

$$\beta \sin \left(\phi + \frac{\pi}{4} \right) = \frac{1}{\sqrt{2}} \quad (3.33)$$

This defines β as a function of ϕ which is shown in Figure 3.6 as the curve bounding the shaded area where $v'_{\perp} > c$.

e) To find the extrema of v'_{\perp} as a function of ϕ we differentiate (3.11) and get

$$\frac{d}{d\phi} \left(\frac{v'_{\perp}}{c} \right) = \frac{\beta(\cos \phi - \beta)}{(1 - \beta \cos \phi)^2}. \quad (3.34)$$

This is zero for $\phi = \phi_m$ where:

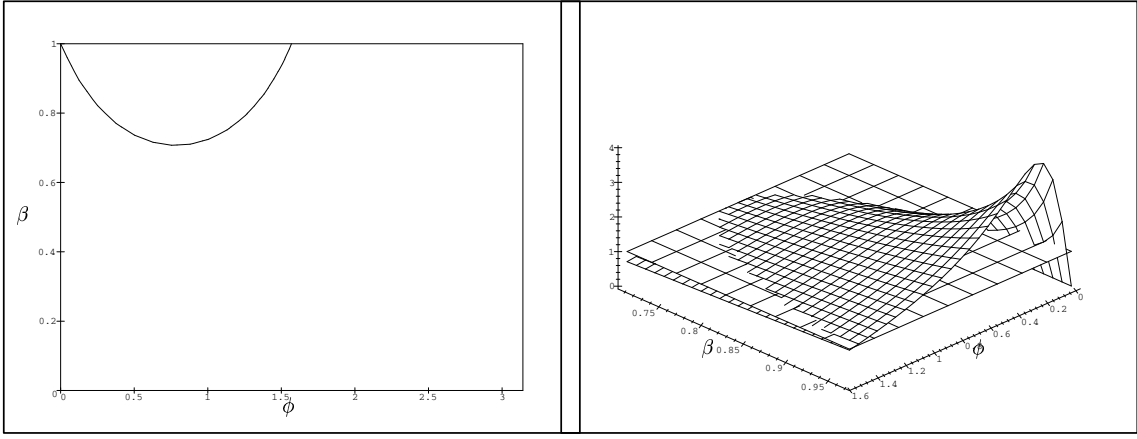

Figure 3.6: The region between the horizontal line and the curve in the upper left hand corner shows where $v'_{\perp}/c > 1$.

Figure 3.7: The curved surface is v'_{\perp}/c as a function of β and ϕ . The plane represents the constant function $\beta = 1$.

$$\cos \phi_m = \beta ; \phi_m = \arccos \beta \in]0, \pi/2] \quad (3.35)$$

To see that this is indeed a maximum, we differentiate (3.34) again and get:

$$\frac{d^2}{d\phi^2} \left(\frac{v'_{\perp}}{c} \right) = -\beta \left(\frac{\sin \phi}{(1 - \beta \cos \phi)^2} + 2 \frac{\beta \sin \phi (\cos \phi - \beta)}{(1 - \beta \cos \phi)^3} \right) \quad (3.36)$$

At the extremum

$$\frac{d^2}{d\phi^2} \left(\frac{v'_{\perp}}{c} \right) \Big|_{\phi_m} = -\frac{\beta \sin \phi_m}{(1 - \beta^2)^2} < 0 \quad (3.37)$$

showing that ϕ_m corresponds to a maximum. From (3.11) and (3.35) the maximum apparent transverse speed is given:

$$(v'_{\perp})_{max} = \frac{\beta c}{\sqrt{1 - \beta^2}} \quad (3.38)$$

From this and (3.35) we see that

$$(v'_{\perp})_{max} \xrightarrow{\beta \rightarrow 1} \infty ; \phi_m \xrightarrow{\beta \rightarrow 1} 0 . \quad (3.39)$$

Figure 3.7 shows v'_{\perp}/c as a function of β and ϕ in the region $(\beta, \phi) \in [2^{-1/2}, 1[\times [0, \pi/2]$.

f) We have the equations for relativistic Doppler-shift:

$$\frac{\lambda_{1,2}}{\lambda_0} = \frac{1 \mp \beta \cos \phi}{\sqrt{1 - \beta^2}} \quad (3.40)$$

We add them, define an auxiliary ratio ρ and solve for β .

$$\rho := \frac{\lambda_1 + \lambda_2}{2 \lambda_0} = \frac{1}{\sqrt{1 - \beta^2}} \quad (3.41)$$

$$\rho^2 (1 - \beta^2) = 1 \quad (3.42)$$

$$\beta = \sqrt{1 - 1/\rho^2} = \sqrt{1 - \frac{4 \lambda_0^2}{(\lambda_1 + \lambda_2)^2}} \quad (3.43)$$

giving

$$\alpha = 4 \quad (3.44)$$

Adding equation (3.43) to the set of equations (3.18) and (3.21) we have three equations which can be solved for the three unknowns β , ϕ and R . For instance, we may calculate β from (3.43), insert that into (3.21), and solve for ϕ . The distance R can then be obtained from (3.18). Thus the measurement of the Doppler-shifted wavelengths turns out to give an estimate of the distance to the source provided that ω_1 and ω_2 are known.

3.3 Grading scheme

Part 1(a)	
Answer i): equation (3.2), ω_1 in the range (16.5-17.5) mas/day	0.8
Answer ii): equation (3.3), ω_2 in the range (8.2-9.2) mas/day	0.8
Answer iii): equation (3.4), for $v'_{1,\perp}$ in the range (1.13-1.30)c	0.2
Answer iv): equation (3.6), for $v'_{2,\perp}$ in the range (0.56-0.70)c	0.2
Part 1(b)	
Answer i): $v'_\perp(\beta, \phi)$, equation (3.11)	2.5
Answer ii): $\omega(\beta, \phi)$, equation (3.12)	0.5
Part 1(c)	
Answer i): $\phi(\omega_1, \omega_2)$, equation (3.19)	0.3
Answer ii): $\beta(\omega_1, \omega_2)$, equation (3.21)	0.3
Answer iii): ϕ numerical in the range $67^\circ - 71^\circ$	0.2
Answer iv): β numerical in the range 0.81-0.97	0.2
Part 1(d)	
Answer i): Condition $\beta > f(\phi)$, equation (3.29)	1.0
Answer ii): Condition on (β, ϕ) , graph	1.0
Part 1(e)	
Answer: $(v'_\perp)_{max}$, equation (3.38)	1.0
Part 1(f)	
Answer: β in terms of λ -s, by α , equation (3.44)	1.0

29th International Physics Olympiad

Reykjavik, Iceland

Experimental competition

Monday, July 6th, 1998

Time available: 5 hours

Read this first:

Use only the pen provided.

1. Use only the front side of the answer sheets and paper.
2. Use *as little text as possible* in your answers; express yourself primarily with equations, numbers and figures. **Summarize your results on the answer sheets.**
3. Please indicate on all sheets the name of your team, your student number, the page number and the total number of pages.
4. At the end of the exam please put your answer sheets, pages and graphs in numerical order and leave them on your table.
5. Use of a calculator is allowed.

This set of problems consists of 6 pages.

Examination prepared at: University of Iceland, Department of Physics.

Instrumentation provided:

- A Platform with 6 banana jacks
- B Pickup coil embedded into the platform
- C Ferrite U-core with two coils marked ``A" and ``B"
- D Ferrite U-core without coils
- E Aluminium foils of thicknesses: 50 μm , 100 μm and 200 μm
- F Function generator with output leads
- G Two multimeters
- H Six leads with banana plugs
- I Two rubber bands and two plastic spacers

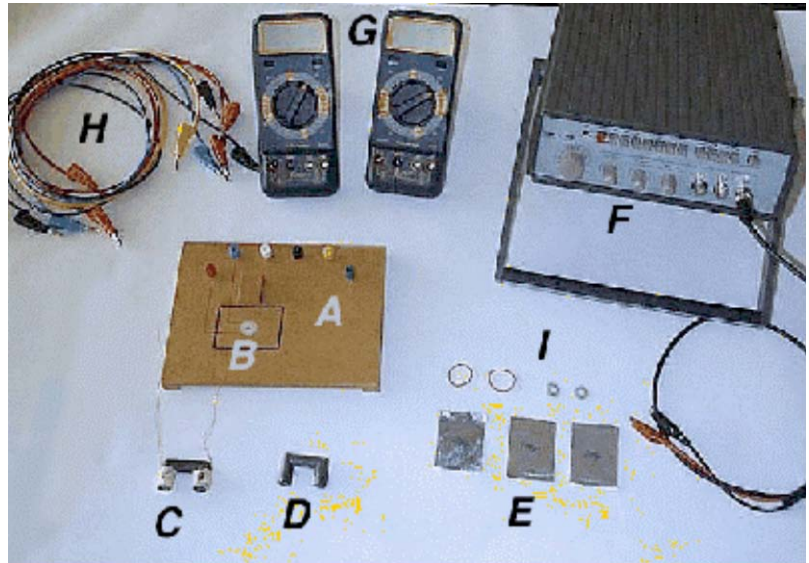

Multimeters

The multimeters are two-terminal devices that in this experiment are used for measuring AC voltages, AC currents, frequency and resistance. In all cases one of the terminals is the one marked **COM**. For the voltage, frequency and resistance measurements the other terminal is the red one marked **V- Ω** . For current measurements the other terminal is the yellow one marked **mA**. With the central dial you select the meter function (**V~** for AC voltage, **A~** for AC current, **Hz** for frequency and **Ω** for resistance) and the measurement range. For the AC modes the measurement uncertainty is \pm (4% of reading + 10 units of the last digit). **To get accurate current measurements a change of range is recommended if the reading is less than 10% of full scale.**

Function generator

To turn on the generator you press in the red button marked **PWR**. Select the 10 kHz range by pressing the button marked **10k**, and select the sine waveform by pressing the second button from the right marked with a wave symbol. No other buttons should be selected. You can safely turn the amplitude knob fully clockwise. The frequency is selected with the large dial on the left. The dial reading multiplied by the range selection gives the output frequency. The frequency can be verified at any time with one of the multimeters. Use the output marked **MAIN**, which has 50 Ω internal resistance.

Ferrite cores

Handle the ferrite cores gently, they are brittle!! Ferrite is a ceramic magnetic material, with low electrical conductivity. Eddy current losses in the cores are therefore low.

Banana jacks

To connect a coil lead to a banana jack, you loosen the colored plastic nut, place the tinned end between the metal nut and plastic nut, and tighten it again.

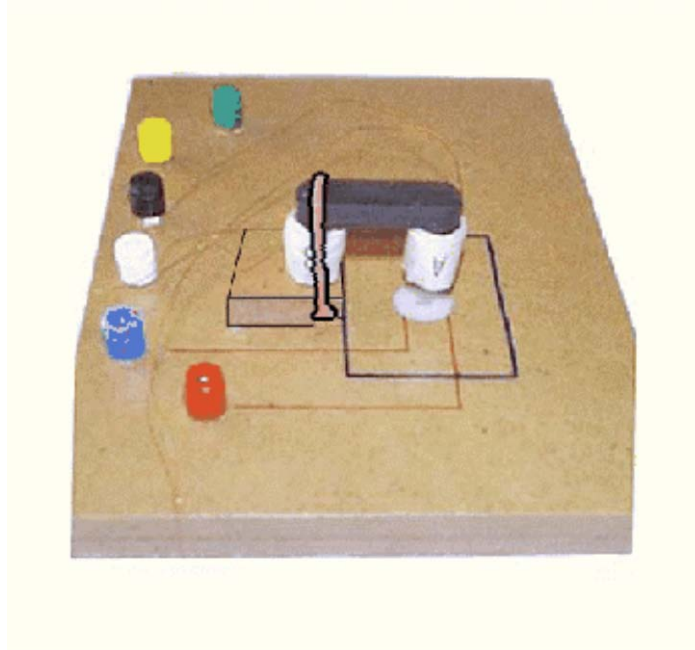

Figure 1: *Experimental arrangement for part I.*

Part I. Magnetic shielding with eddy currents

Time-dependent magnetic fields induce eddy currents in conductors. The eddy currents in turn produce a counteracting magnetic field. In superconductors the induced eddy currents will expel the magnetic field completely from the interior of the conductor. Due to the finite conductivity of normal metals they are not as effective in shielding magnetic fields.

To describe the shielding effect of aluminium foils we will apply a phenomenological model

$$B = B_0 e^{-\alpha d} \quad (1)$$

where B_0 is the magnetic field in the absence of foils. B is the magnetic field beneath the foils, α an attenuation constant, and d the foil thickness.

Experiment

Put the ferrite core with the coils, with legs down, on the raised block such that coil A is directly above the pickup coil embedded in the platform, as shown in Figure 1. Secure the core on the block by stretching the rubber bands over the core and under the block recess.

1. Connect the leads for coils A and B to the jacks. Measure the resistance of all coils to make sure you have good connections. You should expect values of less than 10Ω . Write your values in field 1 on the answer sheet.
2. Collect data to validate the model above and evaluate the attenuation constant α for the aluminum foils ($50 - 300 \mu\text{m}$), for frequencies in the range of $5 - 20 \text{ kHz}$. Place the foils inside the square, above the pickup coil, and apply a sinusoidal voltage to coil A. Write your results in field 2 on the answer sheet.
3. Plot α versus frequency, and write in field 3 on the answer sheet, an expression describing the function $\alpha(f)$.

Part II. Magnetic flux linkage

The response of two coils on a closed ferrite core to an external alternating voltage (V_g) from a sinusoidal signal generator is studied.

Theory

In the following basic theoretical discussion, and in the treatment of the data, it is assumed that the ohmic resistance in the two coils and hysteresis losses in the core have insignificant influence on the measured currents and voltages. Because of these simplifications in the treatment below, some deviations will occur between measured and calculated values.

Single coil

Let us first look at a core with a single coil, carrying a current I . The magnetic flux Φ , that the current creates in the ferrite core inside the coil, is proportional to the current I and to the number of windings N . The flux depends furthermore on a geometrical factor g , which is determined by the size and shape of the core, and the magnetic permeability $\mu = \mu_r \mu_0$, which describes the magnetic properties of the core material. The relative permeability is denoted μ_r and μ_0 is the permeability of free space. The magnetic flux Φ is thus given by

$$\Phi = \mu g N I = c N I \quad (2)$$

where $c = \mu g$. The induced voltage is given by Faraday's law of induction,

$$\varepsilon(t) = -N \frac{d\Phi(t)}{dt} = -c N^2 \frac{dI(t)}{dt} \quad (3)$$

The conventional way to describe the relationship between current and voltage for a coil is through the self inductance of the coil L , defined by,

$$\varepsilon(t) = -L \frac{dI(t)}{dt} \quad (4)$$

A sinusoidal signal generator connected to the coil will drive a current through it given by

$$I(t) = I_0 \sin \omega t \quad (5)$$

where ω is the angular frequency and I_0 is the amplitude of the current. As follows from equation (3) this alternating current will induce a voltage across the coil given by

$$\varepsilon(t) = -\omega c N^2 I_0 \cos \omega t \quad (6)$$

The current will be such that the induced voltage is equal to the signal generator voltage V_g . There is a 90 degree phase difference between the current and the voltage. If we only look at the magnitudes of the alternating voltage and current, allowing for this phase difference, we have

$$\varepsilon = \omega c N^2 I \quad (7)$$

Two coils

Let us now assume that we have two coils on one core. Ferrite cores can be used to link magnetic flux between coils. In an ideal core the flux will be the same for all cross sections of the core. Due to flux leakage in real cores a second coil on the core will in general experience a reduced flux compared to the

flux-generating coil. The flux Φ_B in the secondary coil B is therefore related to the flux Φ_A in the primary coil A through

$$\Phi_B = k\Phi_A \quad (8)$$

Similarly a flux component Φ_B created by a current in coil B will create a flux $\Phi_A = k\Phi_B$ in coil A. The factor k , which is called the coupling factor, has a value less than one.

The ferrite core under study has two coils A and B in a transformer arrangement. Let us assume that coil A is the primary coil (connected to the signal generator). If no current flows in coil B ($I_B=0$), the induced voltage ε_A due to I_A is equal and opposite to V_g . The flux created by I_A inside the secondary coil is determined by equation (8) and the induced voltage in coil B is

$$\varepsilon_B = \omega k N_A N_B I_A \quad (9)$$

If a current I_B flows in coil B, it will induce a voltage in coil A which is described by a similar expression. The total voltage across the coil A will then be given by

$$V_g = \varepsilon_A = \omega c N_A^2 I_A - \omega k N_A N_B I_B \quad (10)$$

The current in the secondary coil thus induces an opposing voltage in the primary coil, leading to an increase in I_A . A similar equation can be written for ε_B . As can be verified by measurements, k is independent of which coil is taken as the primary coil.

Experiment

Place the two U-cores together as shown in Figure 2, and fasten them with the rubber bands. Set the function generator to produce a 10 kHz, sine wave. Remember to set the multimeters to the most sensitive range suitable for each measurement. The numbers of the windings of the two coils, A and B, are: $N_A = 150$ turns and $N_B = 100$ turns (± 1 turn on each coil).

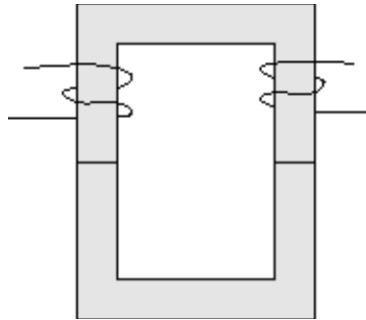

Figure 2: A transformer with a closed magnetic circuit.

1. Derive algebraic expressions for the self inductances L_A and L_B , and the coupling factor k , in terms of measured and given quantities and write your results in field 1.a on the answer sheet. Draw circuit diagrams in field 1.b on the answer sheet, showing how these quantities are determined. Calculate the numerical values of L_A , L_B and k and write their values in field 1.c on the answer sheet.
2. When the secondary coil is short-circuited, the current I_P in the primary coil will increase. Use the equations above to derive an expression giving I_P explicitly and write your result in field 2.a on the answer sheet. Measure I_P and write your value in field 2.b on the answer sheet.
3. Coils A and B can be connected in series in two different ways such that the two flux contributions are either added to or subtracted from each other.
 - 3.1. Find the self inductance of the serially connected coils, L_{A+B} , from measured quantities in the case where the flux contributions produced by the current I in the two coils add to (strengthen) each other and write your answer in field 3.1 on the answer sheet.

- 3.2. Measure the voltages V_A and V_B when the flux contributions of the two coils oppose each other. Write your values in field 3.2.a on the answer sheet and the ratio of the voltages in field 3.2.b. Derive an expression for the ratio of the voltages across the two coils and write it in field 3.2.c on the answer sheet.
4. Use the results obtained to verify that the self inductance of a coil is proportional to the square of the number of its windings and write your result in field 4 on the answer sheet.
 5. Verify that it was justified to neglect the resistances of the coils and write your arguments as mathematical expressions in field 5 on the answer sheet.
 6. Thin plastic spacers inserted between the two half cores (as shown in Figure 3) reduce the coil inductances drastically. Use this reduction to determine the relative permeability μ_r of the ferrite material, given Ampere's law and continuity of the magnetic field \mathbf{B} across the ferrite - plastic interface.

Assume $\mu = \mu_0 = 4\pi \times 10^{-7} \text{ N s}^2/\text{C}^2$ for the plastic spacers and a spacer thickness of 1.6 mm. The geometrical factor can be determined from Ampere's law

$$\oint \frac{1}{\mu} B dl = I_{total} \quad (11)$$

where I_{total} is the total current flowing through a surface bounded by the integration path. Write your algebraic expression for μ_r in field 6.a on the answer sheet and your numerical value in field 6.b.

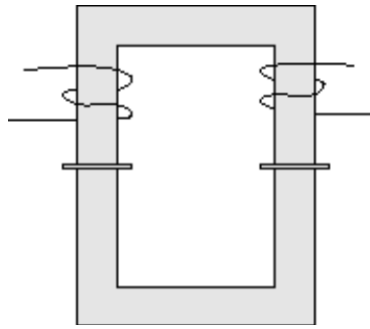

Figure 3: The ferrite cores with the two spacers in place.

30th International Physics Olympiad

Padua, Italy

Theoretical competition

Thursday, July 22nd, 1999

Please read this first:

1. The time available is 5 hours for 3 problems.
2. Use only the pen provided.
3. Use only the **front side** of the provided sheets.
4. In addition to the problem texts, that contain the specific data for each problem, a sheet is provided containing a number of general physical constants that may be useful for the problem solutions.
5. Each problem should be answered on separate sheets.
6. In addition to "blank" sheets where you may write freely, for each problem there is an *Answer sheet* where you **must** summarize the results you have obtained. Numerical results must be written with as many digits as appropriate to the given data; don't forget the units.
7. Please write on the "blank" sheets whatever you deem important for the solution of the problem, that you wish to be evaluated during the marking process. However, you should use mainly equations, numbers, symbols, figures, and use *as little text as possible*.
8. **It's absolutely imperative** that you write on top of *each* sheet that you'll use: your name ("NAME"), your country ("TEAM"), your student code (as shown on the identification tag, "CODE"), and additionally on the "blank" sheets: the problem number ("**Problem**"), the progressive number of each sheet (from 1 to N , "**Page n.**") and the total number (N) of "blank" sheets that you use and wish to be evaluated for that problem ("**Page total**"). It is also useful to write the section you are answering at the beginning of each such section. If you use some sheets for notes that you don't wish to be evaluated by the marking team, just put a large cross through the whole sheet, and don't number it.
9. When you've finished, turn in all sheets in proper order (for each problem: answer sheet first, then used sheets in order; unused sheets and problem text at the bottom) and put them all inside the envelope where you found them; then leave everything on your desk. You are not allowed to take **any** sheets out of the room.

This set of problems consists of 13 pages (including this one, the answer sheets and the page with the physical constants)

These problems have been prepared by the Scientific Committee of the 30th IPHO, including professors at the Universities of Bologna, Naples, Turin and Trieste.

Problem 1

Absorption of radiation by a gas

A cylindrical vessel, with its axis vertical, contains a molecular gas at thermodynamic equilibrium. The upper base of the cylinder can be displaced freely and is made out of a glass plate; let's assume that there is no gas leakage and that the friction between glass plate and cylinder walls is just sufficient to damp oscillations but doesn't involve any significant loss of energy with respect to the other energies involved. Initially the gas temperature is equal to that of the surrounding environment. The gas can be considered as perfect within a good approximation. Let's assume that the cylinder walls (including the bases) have a very low thermal conductivity and capacity, and therefore the heat transfer between gas and environment is very slow, and can be neglected in the solution of this problem.

Through the glass plate we send into the cylinder the light emitted by a constant power laser; this radiation is easily transmitted by air and glass but is completely absorbed by the gas inside the vessel. By absorbing this radiation the molecules reach excited states, where they quickly emit infrared radiation returning in steps to the molecular ground state; this infrared radiation, however, is further absorbed by other molecules and is reflected by the vessel walls, including the glass plate. The energy absorbed from the laser is therefore transferred in a very short time into thermal movement (molecular chaos) and thereafter stays in the gas for a sufficiently long time.

We observe that the glass plate moves upwards; after a certain irradiation time we switch the laser off and we measure this displacement.

1. Using the data below and - if necessary - those on the sheet with physical constants, compute the temperature and the pressure of the gas after the irradiation. *[2 points]*
2. Compute the mechanical work carried out by the gas as a consequence of the radiation absorption. *[1 point]*
3. Compute the radiant energy absorbed during the irradiation. *[2 points]*
4. Compute the power emitted by the laser that is absorbed by the gas, and the corresponding number of photons (and thus of elementary absorption processes) per unit time. *[1.5 points]*
5. Compute the efficiency of the conversion process of optical energy into a change of mechanical potential energy of the glass plate. *[1 point]*

Thereafter the cylinder axis is slowly rotated by 90° , bringing it into a horizontal direction. The heat exchanges between gas and vessel can still be neglected.

6. State whether the pressure and/or the temperature of the gas change as a consequence of such a rotation, and - if that is the case - what is its/their new value. *[2.5 points]*

Data

Room pressure: $p_0 = 101.3 \text{ kPa}$

Room temperature: $T_0 = 20.0^\circ\text{C}$

Inner diameter of the cylinder: $2r = 100 \text{ mm}$

Mass of the glass plate: $m = 800 \text{ g}$

Quantity of gas within the vessel: $n = 0.100 \text{ mol}$

Molar specific heat at constant volume of the gas: $c_V = 20.8 \text{ J}/(\text{mol}\cdot\text{K})$

Emission wavelength of the laser: $\lambda = 514 \text{ nm}$

Irradiation time: $\Delta t = 10.0 \text{ s}$

Displacement of the movable plate after irradiation: $\Delta s = 30.0 \text{ mm}$



NAME _____

TEAM _____

CODE _____

Problem	1
Page n.	A
Page total	

Answer sheet

In this problem you are requested to give your results both as analytical expressions and with numerical data and units: write expressions first and then data (e.g. $A=bc=1.23 \text{ m}^2$).

1. Gas temperature after the irradiation
 Gas pressure after the irradiation

2. Mechanical work carried out

3. Overall optical energy absorbed by the gas

4. Optical laser power absorbed by the gas
 Absorption rate of photons (number of absorbed photons per unit time)

5. Efficiency in the conversion of optical energy into change of mechanical potential energy
 of the glass plate

6. Owing to the cylinder rotation, is there a pressure change? YES NO
 If yes, what is its new value?
 Owing to the cylinder rotation, is there a temperature change? YES NO
 If yes, what is its new value?

Physical constants and general data

In addition to the numerical data given within the text of the individual problems, the knowledge of some general data and physical constants may be useful, and you may find them among the following ones. These are nearly the most accurate data currently available, and they have thus a large number of digits; you are expected, however, to write your results with a number of digits that must be appropriate for each problem.

Speed of light in vacuum: $c = 299792458 \text{ m}\cdot\text{s}^{-1}$

Magnetic permeability of vacuum: $\mu_0 = 4\pi\cdot 10^{-7} \text{ H}\cdot\text{m}^{-1}$

Dielectric constant of vacuum: $\epsilon_0 = 8.8541878 \text{ pF}\cdot\text{m}^{-1}$

Gravitational constant: $G = 6.67259\cdot 10^{-11} \text{ m}^3/(\text{kg}\cdot\text{s}^2)$

Gas constant: $R = 8.314510 \text{ J}/(\text{mol}\cdot\text{K})$

Boltzmann's constant: $k = 1.380658\cdot 10^{-23} \text{ J}\cdot\text{K}^{-1}$

Stefan's constant: $\sigma = 56.703 \text{ nW}/(\text{m}^2\cdot\text{K}^4)$

Proton charge: $e = 1.60217733\cdot 10^{-19} \text{ C}$

Electron mass: $m_e = 9.1093897\cdot 10^{-31} \text{ kg}$

Planck's constant: $h = 6.6260755\cdot 10^{-34} \text{ J}\cdot\text{s}$

Base of centigrade scale: $T_K = 273.15 \text{ K}$

Sun mass: $M_S = 1.991\cdot 10^{30} \text{ kg}$

Earth mass: $M_E = 5.979\cdot 10^{24} \text{ kg}$

Mean radius of Earth: $r_E = 6.373 \text{ Mm}$

Major semiaxis of Earth orbit: $R_E = 1.4957\cdot 10^{11} \text{ m}$

Sidereal day: $d_S = 86.16406 \text{ ks}$

Year: $y = 31.558150 \text{ Ms}$

Standard value of the gravitational field at the Earth surface: $g = 9.80665 \text{ m}\cdot\text{s}^{-2}$

Standard value of the atmospheric pressure at sea level: $p_0 = 101325 \text{ Pa}$

Refractive index of air for visible light, at standard pressure and 15 °C: $n_{\text{air}} = 1.000277$

Solar constant: $S = 1355 \text{ W}\cdot\text{m}^{-2}$

Jupiter mass: $M = 1.901\cdot 10^{27} \text{ kg}$

Equatorial Jupiter radius: $R_B = 69.8 \text{ Mm}$

Average radius of Jupiter's orbit: $R = 7.783\cdot 10^{11} \text{ m}$

Jovian day: $d_J = 35.6 \text{ ks}$

Jovian year: $y_J = 374.32 \text{ Ms}$

$\pi: 3.14159265$

Problem 2

Magnetic field with a V-shaped wire

Among the first successes of the interpretation by Ampère of magnetic phenomena, we have the computation of the magnetic field \mathbf{B} generated by wires carrying an electric current, as compared to early assumptions originally made by Biot and Savart.

A particularly interesting case is that of a very long thin wire, carrying a constant current i , made out of two rectilinear sections and bent in the form of a "V", with angular half-span¹ α (see figure). According to Ampère's computations, the magnitude B of the magnetic field in a given point P lying on the axis of the "V", outside of it and at a distance d from its vertex, is proportional to $\tan\left(\frac{\alpha}{2}\right)$. Ampère's work was later embodied in Maxwell's electromagnetic theory, and is universally accepted.

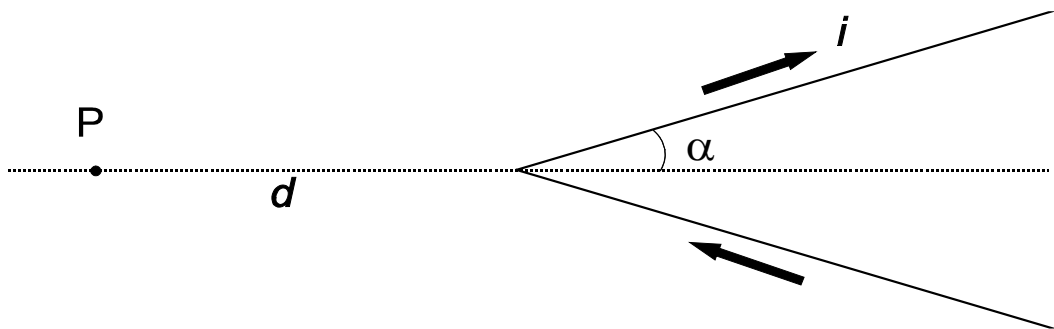

Using our contemporary knowledge of electromagnetism,

1. Find the direction of the field \mathbf{B} in P . [1 point]
2. Knowing that the field is proportional to $\tan\left(\frac{\alpha}{2}\right)$, find the proportionality factor k in

$$|\mathbf{B}(P)| = k \tan\left(\frac{\alpha}{2}\right). \quad [1.5 \text{ points}]$$

3. Compute the field \mathbf{B} in a point P^* symmetric to P with respect to the vertex, *i.e.* along the axis and at the same distance d , but inside the "V" (see figure). [2 points]

¹ Throughout this problem α is expressed in radians

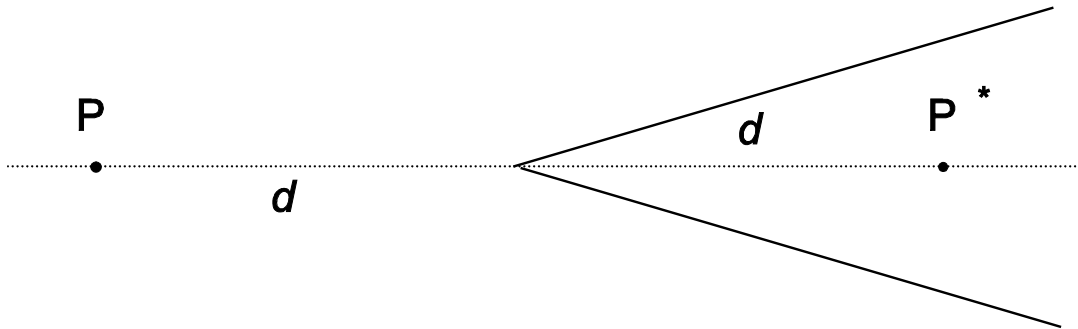

4. In order to measure the magnetic field, we place in P a small magnetic needle with moment of inertia I and magnetic dipole moment μ ; it oscillates around a fixed point in a plane containing the direction of \mathbf{B} . Compute the period of small oscillations of this needle as a function of B . [2.5 points]

In the same conditions Biot and Savart had instead assumed that the magnetic field in P might have been (we use here the modern notation) $B(P) = \frac{i\mu_0\alpha}{\pi^2 d}$, where μ_0 is the magnetic permeability of vacuum. In fact they attempted to decide with an experiment between the two interpretations (Ampère's and Biot and Savart's) by measuring the oscillation period of the magnetic needle as a function of the "V" span. For some α values, however, the differences are too small to be easily measurable.

5. If, in order to distinguish experimentally between the two predictions for the magnetic needle oscillation period T in P, we need a difference by at least 10%, namely $T_1 > 1.10 T_2$ (T_1 being the Ampere prediction and T_2 the Biot-Savart prediction) state in which range, approximately, we must choose the "V" half-span α for being able to decide between the two interpretations. [3 points]

Hint

Depending on which path you follow in your solution, the following trigonometric equation might

be useful: $\tan\left(\frac{\alpha}{2}\right) = \frac{\sin \alpha}{1 + \cos \alpha}$



NAME _____

TEAM _____

CODE _____

Problem	2
Page n.	A
Page total	

Answer sheet

In this problem write the requested results as analytic expressions, not as numerical values and units, unless explicitly indicated.

- Using the following sketch draw the direction of the \mathbf{B} field (the length of the vector is not important). The sketch is a spatial perspective view.

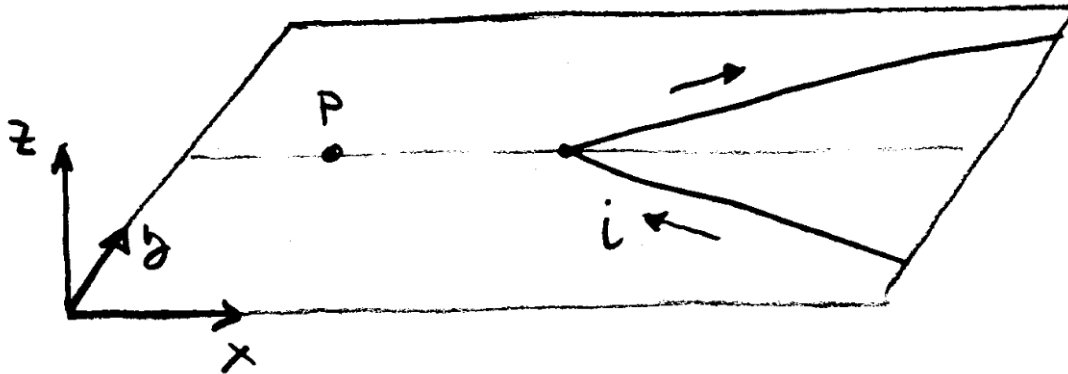

- Proportionality factor k
- Absolute value of the magnetic field intensity at the point P^* , as described in the text.....

Draw the direction of the \mathbf{B} field in the above sketch

- Period of the small angle oscillations of the magnet
- Write for which range of α values (indicating here the numerical values of the range limits) the ratio between the oscillation periods, as predicted by Ampère and by Biot and Savart, is larger than 1.10:

.....

Final

Problem 3

A space probe to Jupiter

We consider in this problem a method frequently used to accelerate space probes in the desired direction. The space probe flies by a planet, and can significantly increase its speed and modify considerably its flight direction, by taking away a very small amount of energy from the planet's orbital motion. We analyze here this effect for a space probe passing near Jupiter.

The planet Jupiter orbits around the Sun along an elliptical trajectory, that can be approximated by a circumference of average radius R ; in order to proceed with the analysis of the physical situation we must first:

1. Find the speed V of the planet along its orbit around the Sun. [1.5 points]
2. When the probe is between the Sun and Jupiter (on the segment Sun-Jupiter), find the distance from Jupiter where the Sun's gravitational attraction balances that by Jupiter. [1 point]

A space probe of mass $m = 825$ kg flies by Jupiter. For simplicity assume that the trajectory of the space probe is entirely in the plane of Jupiter's orbit; in this way we neglect the important case in which the space probe is expelled from Jupiter's orbital plane.

We only consider what happens in the region where Jupiter's attraction overwhelms all other gravitational forces.

In the reference frame of the Sun's center of mass the initial speed of the space probe is $v_0 = 1.00 \cdot 10^4$ m/s (along the positive y direction) while Jupiter's speed is along the negative x direction (see figure 1); by "initial speed" we mean the space probe speed when it's in the interplanetary space, still far from Jupiter but already in the region where the Sun's attraction is negligible with respect to Jupiter's. We assume that the encounter occurs in a sufficiently short time to allow neglecting the change of direction of Jupiter along its orbit around the Sun. We also assume that the probe passes behind Jupiter, i.e. the x coordinate is greater for the probe than for Jupiter when the y coordinate is the same.

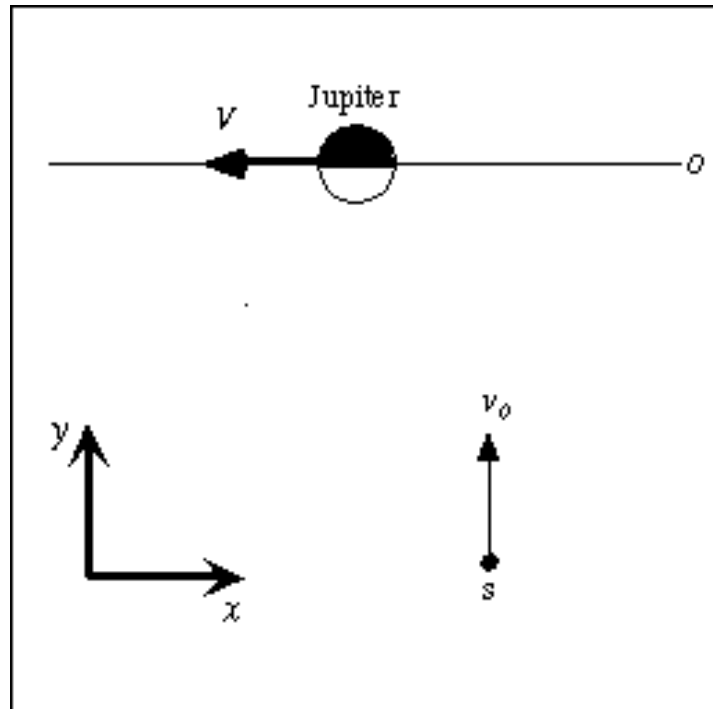

Figure 1: View in the Sun center of mass system. O denotes Jupiter's orbit, s is the space probe.

3. Find the space probe's direction of motion (as the angle φ between its direction and the x axis) and its speed v' in Jupiter's reference frame, when it's still far away from Jupiter. [2 points]
4. Find the value of the space probe's total mechanical energy E in Jupiter's reference frame, putting – as usual – equal to zero the value of its potential energy at a very large distance, in this case when it is far enough to move with almost constant velocity owing to the smallness of all gravitational interactions. [1 point]

The space probe's trajectory in the reference frame of Jupiter is a hyperbola and its equation in polar coordinates in this reference frame is

$$\frac{1}{r} = \frac{GM}{v'^2 b^2} \left(1 + \sqrt{1 + \frac{2Ev'^2 b^2}{G^2 M^2 m}} \cos \theta \right) \quad (1)$$

where b is the distance between one of the asymptotes and Jupiter (the so called *impact parameter*), E is the probe's total mechanical energy in Jupiter's reference frame, G is the gravitational constant, M is the mass of Jupiter, r and θ are the polar coordinates (the radial distance and the polar angle).

Figure 2 shows the two branches of a hyperbola as described by equation (1); the asymptotes and the polar co-ordinates are also shown. Note that equation (1) has its origin in the "attractive focus" of the hyperbola. The space probe's trajectory is the attractive trajectory (the

Final

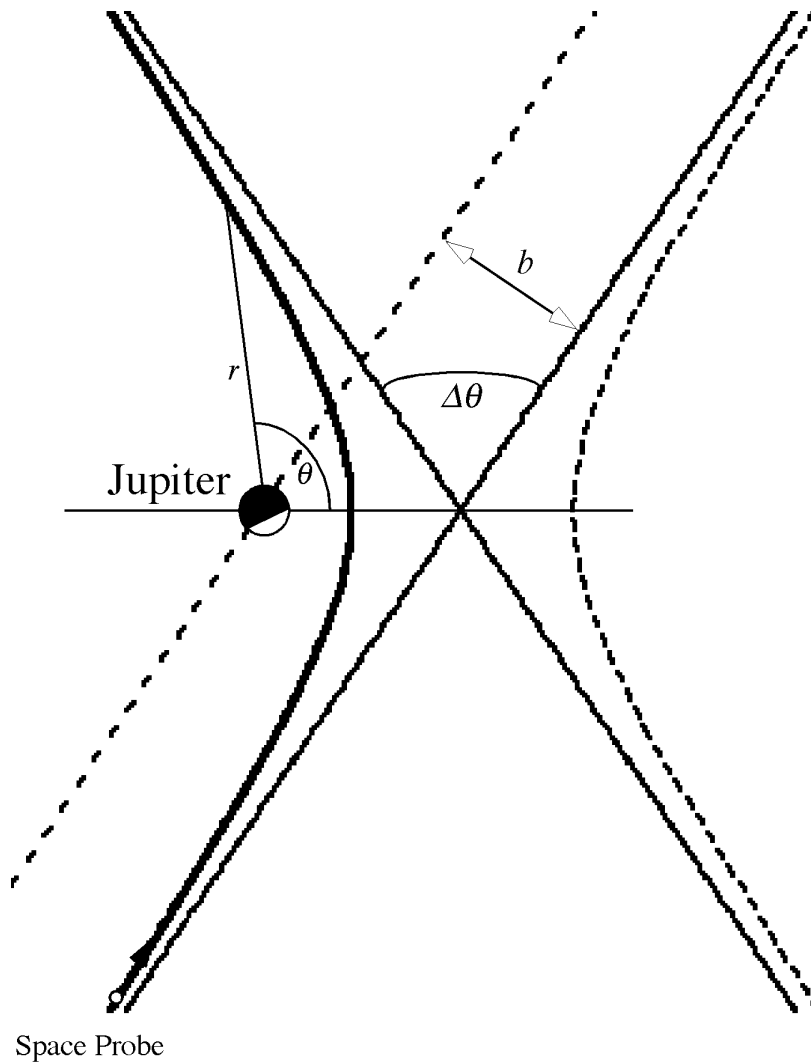

Figure 2

5. Using equation (1) describing the space probe's trajectory, find the total angular deviation $\Delta\theta$ in Jupiter's reference frame (as shown in figure 2) and express it as a function of initial speed v' and impact parameter b . [2 points]
6. Assume that the probe cannot pass Jupiter at a distance less than three Jupiter radii from the center of the planet; find the minimum possible impact parameter and the maximum possible angular deviation. [1 point]
7. Find an equation for the final speed v'' of the probe in the Sun's reference frame as a function only of Jupiter's speed V , the probe's initial speed v_0 and the deviation angle $\Delta\theta$. [1 point]
8. Use the previous result to find the numerical value of the final speed v'' in the Sun's reference frame when the angular deviation has its maximum possible value. [0.5 points]

Hint

Depending on which path you follow in your solution, the following trigonometric formulas might be useful:

$$\sin(\alpha + \beta) = \sin \alpha \cos \beta + \cos \alpha \sin \beta$$

$$\cos(\alpha + \beta) = \cos \alpha \cos \beta - \sin \alpha \sin \beta$$



NAME _____

TEAM _____

CODE _____

Problem	3
Page n.	A
Page total	

Answer sheet

Unless explicitly requested to do otherwise, in this problem you are supposed to write your results both as analytic equations (first) and then as numerical results and units (e.g. $A=bc=1.23 \text{ m}^2$).

1. Speed V of Jupiter along its orbit
 2. Distance from Jupiter where the two gravitational attractions balance each other
 3. Initial speed v' of the space probe in Jupiter's reference frame
and the angle φ its direction forms with the x axis, as defined in figure 1,
 4. Total energy E of the space probe in Jupiter's reference frame
 5. Write a formula linking the probe's deviation $\Delta\theta$ in Jupiter's reference frame to the impact parameter b , the initial speed v' and other known or computed quantities
 6. If the distance from Jupiter's center can't be less than three Jovian radii, write the minimum impact parameter and the maximum angular deviation: $b =$;
 $\Delta\theta =$
 7. Equation for the final probe speed v'' in the Sun's reference frame as a function of V , v_0 and $\Delta\theta$
 8. Numerical value of the final speed in the Sun's reference frame when the angular deviation has its maximum value as computed in step 6
- Final

30th International Physics Olympiad

Padua, Italy

Experimental competition

Tuesday, July 20th, 1999

Before attempting to assemble your equipment, read the problem text completely!

Please read this first:

1. The time available is 5 hours for one experiment only.
2. Use only the pen provided.
3. Use only the **front side** of the provided sheets.
4. In addition to "blank" sheets where you may write freely, there is a set of *Answer sheets* where you **must** summarize the results you have obtained. Numerical results must be written with as many digits as appropriate; don't forget the units. Try – whenever possible – to estimate the experimental uncertainties.
5. Please write on the "blank" sheets the results of all your measurements and whatever else you deem important for the solution of the problem, that you wish to be evaluated during the marking process. However, you should use mainly equations, numbers, symbols, graphs, figures, and use *as little text as possible*.
6. **It's absolutely imperative** that you write on top of *each* sheet that you'll use: your name ("NAME"), your country ("TEAM"), your student code (as shown on your identification tag, "CODE"), and additionally on the "blank" sheets: the progressive number of each sheet (from 1 to N , "Page n.") and the total number (N) of "blank" sheets that you use and wish to be evaluated ("Page total"); leave the "Problem" field blank. It is also useful to write the number of the section you are answering at the beginning of each such section. If you use some sheets for notes that you don't wish to be evaluated by the marking team, just put a large cross through the whole sheet, and don't number it.
7. When you've finished, turn in all sheets in proper order (answer sheets first, then used sheets in order, unused sheets and problem text at the bottom) and put them all inside the envelope where you found them; then leave everything on your desk. You are not allowed to take anything out of the room.

This problem consists of 11 pages (including this one and the answer sheets).

This problem has been prepared by the Scientific Committee of the 30th IPhO, including professors at the Universities of Bologna, Naples, Turin and Trieste.

28/09/09

Torsion pendulum

In this experiment we want to study a relatively complex mechanical system – a torsion pendulum – and investigate its main parameters. When its rotation axis is horizontal it displays a simple example of bifurcation.

Available equipment

1. A torsion pendulum, consisting of an outer body (not longitudinally uniform) and an inner threaded rod, with a stand as shown in figure 1
2. A steel wire with handle
3. A long hexagonal nut that can be screwed onto the pendulum threaded rod (needed only for the last exercise)
4. A ruler and a right triangle template
5. A timer
6. Hexagonal wrenches
7. A3 Millimeter paper sheets.
8. An adjustable clamp
9. Adhesive tape
10. A piece of T-shaped rod

The experimental apparatus is shown in figure 1; it is a torsion pendulum that can oscillate either around a horizontal rotation axis or around a vertical rotation axis. The rotation axis is defined by a short steel wire kept in tension. The pendulum has an inner part that is a threaded rod that may be screwed in and out, and can be fixed in place by means of a small hexagonal lock nut. This threaded rod can **not** be extracted from the pendulum body.

When assembling the apparatus in step 5 the steel wire must pass through the brass blocks and through the hole in the pendulum, then must be locked in place by keeping it stretched: lock it first at one end, then use the handle to put it in tension and lock it at the other end.

Warning: The wire must be put in tension only to guarantee the pendulum stability. It's not necessary to strain it with a force larger than about 30 N. While straining it, don't bend the wire against the stand, because it might break.

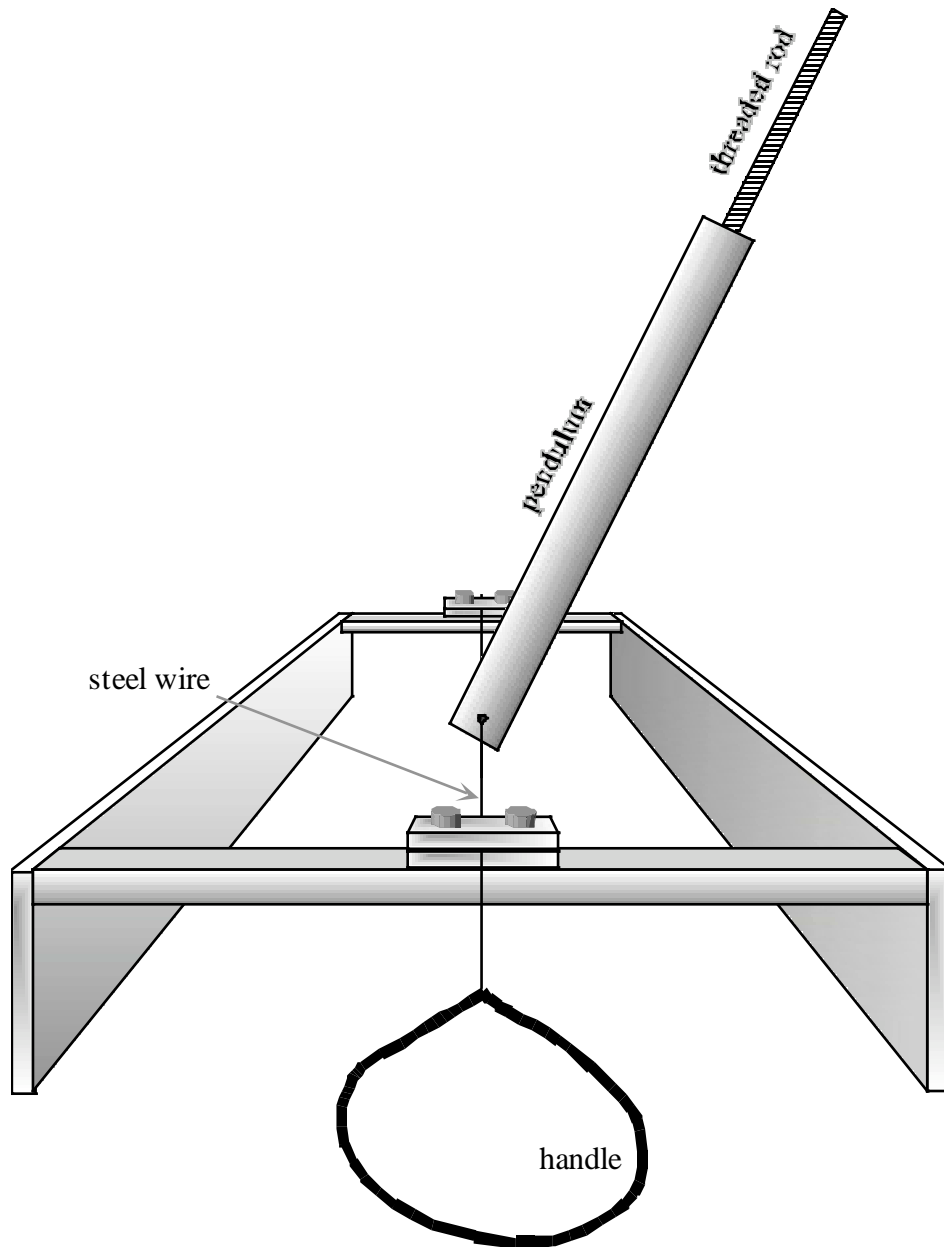

Figure 1: Sketch of the experimental apparatus when its rotation axis is horizontal.

The variables characterizing the pendulum oscillations are:

- the pendulum position defined by the angle θ of deviation from the direction perpendicular to the plane of the stand frame, which is shown horizontal in figure 1.
- the distance x between the free end of the inner threaded rod and the pendulum rotation axis
- the period T of the pendulum oscillations.

The parameters characterizing the system are:

- the torsional elastic constant κ (torque = $\kappa \cdot$ angle) of the steel wire;
- the masses M_1 and M_2 of the two parts of the pendulum (1: outer cylinder¹ and 2: threaded rod);

¹ Including the small hex locking nut.

- the distances R_1 and R_2 of the center of mass of each pendulum part (1: outer cylinder and 2: threaded rod) from the rotation axis. In this case the inner mobile part (the threaded rod) is sufficiently uniform for computing R_2 on the basis of its mass, its length ℓ and the distance x . R_2 is therefore a simple function of the other parameters;
- the moments of inertia I_1 and I_2 of the two pendulum parts (1: outer cylinder and 2: threaded rod). In this case also we assume that the mobile part (the threaded rod) is sufficiently uniform for computing I_2 on the basis of its mass, its length ℓ and the distance x . I_2 is therefore also a simple function of the other parameters;
- the angular position θ_0 (measured between the pendulum and the perpendicular to the plane of the stand frame) where the elastic recall torque is zero. The pendulum is locked to the rotation axis by means of a hex screw, opposite to the threaded rod; therefore θ_0 varies with each installation of the apparatus.

Summing up, the system is described by 7 parameters: $\kappa, M_1, M_2, R_1, I_1, \ell, \theta_0$, but θ_0 changes each time the apparatus is assembled, so that only 6 of them are really constants and the purpose of the experiment is that of determining them, namely $\kappa, M_1, M_2, R_1, I_1, \ell$, **experimentally**. Please note that the inner threaded rod can't be drawn out of the pendulum body, and initially only the total mass $M_1 + M_2$ is given (it is printed on each pendulum).

In this experiment several quantities are linear functions of one variable, and you must estimate the parameters of these linear functions. You can use a linear fit, but alternative approaches are also acceptable. The experimental uncertainties of the parameters can be estimated from the procedure of the linear fit or from the spread of experimental data about the fit.

The analysis also requires a simple formula for the moment of inertia of the inner part (we assume that its transverse dimensions are negligible with respect to its length, see figure 2):

$$I_2(x) = \int_{x-\ell}^x \lambda s^2 ds = \frac{\lambda}{3} (x^3 - (x-\ell)^3) = \frac{\lambda}{3} (3\ell x^2 - 3\ell^2 x + \ell^3) \quad (1)$$

where $\lambda = M_2 / \ell$ is the linear mass density, and therefore

$$I_2(x) = M_2 x^2 - M_2 \ell x + \frac{M_2}{3} \ell^2 \quad (2)$$

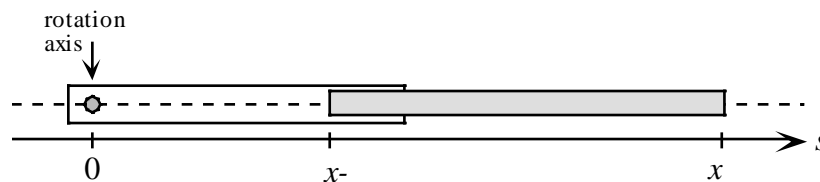

Figure 2: In the analysis of the experiment we can use an equation (eq. 2) for the moment of inertia of a bar whose transverse dimensions are much less than its length. The moment of inertia must be computed about the rotation axis that in this figure crosses the s axis at $s=0$.

Now follow these steps to find the 6 parameters $M_1, M_2, \kappa, R_1, \ell, I_1$:

1. The value of the total mass M_1+M_2 is given (it is printed on the pendulum), and you can find M_1 and M_2 by measuring the distance $R(x)$ between the rotation axis and the center of mass of the pendulum. To accomplish this write first an equation for the position $R(x)$ of the center of mass as a function of x and of the parameters M_1, M_2, R_1, ℓ . [0.5 points]
2. Now measure $R(x)$ for several values of x (at least 3)². Clearly such measurement must be carried out when the pendulum is not attached to the steel wire. Use these measurements and the previous result to find M_1 and M_2 . [3 points]

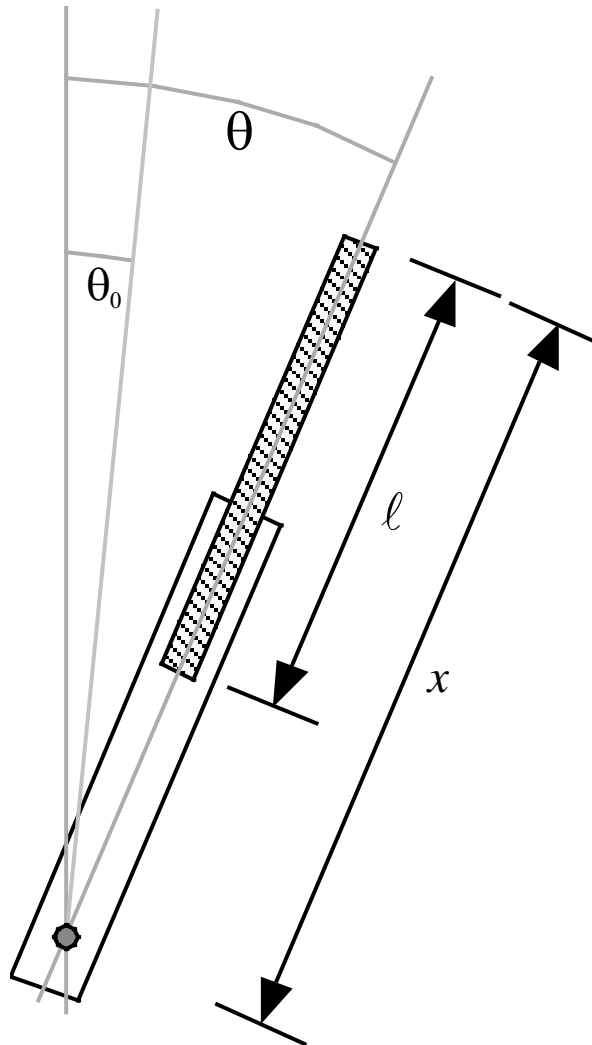

Figure 3: The variables θ and x and the parameters θ_0 and ℓ are shown here.

3. Find an equation for the pendulum total moment of inertia I as a function of x and of the parameters M_2, I_1 and ℓ . [0.5 points]
4. Write the pendulum equation of motion in the case of a horizontal rotation axis, as a function of the angle θ (see figure 3) and of $x, \kappa, \theta_0, M_1, M_2$, the total moment of inertia I and the position $R(x)$ of the center of mass. [1 point]

² The small hex nut must be locked in place every time you move the threaded rod. Its mass is included in M_1 . This locking must be repeated also in the following, each time you move the threaded rod.

5. In order to determine κ , assemble now the pendulum and set it with its rotation axis horizontal. The threaded rod must initially be as far as possible inside the pendulum. Lock the pendulum to the steel wire, with the hex screw, at about half way between the wire clamps and in such a way that its equilibrium angle (under the combined action of weight and elastic recall) deviates sizeably from the vertical (see figure 4). Measure the equilibrium angle θ_e for several values of x (at least 5). [4 points]

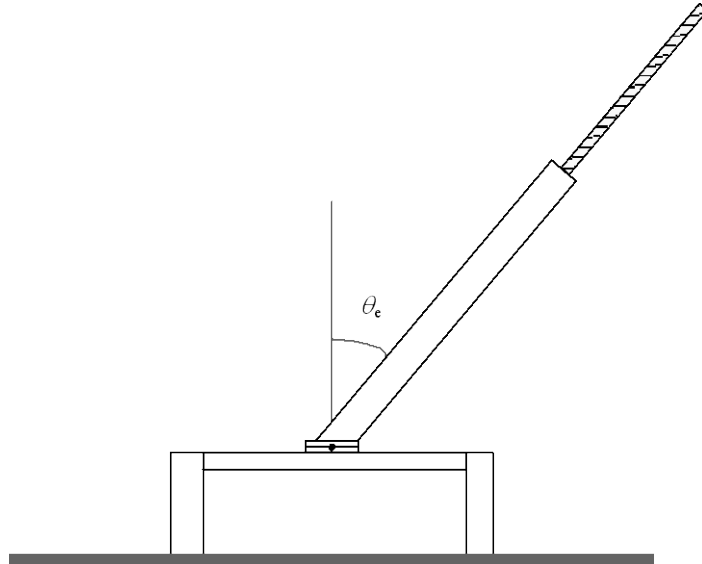

Figure 4: In this measurement set the pendulum so that its equilibrium position deviates from the vertical.

6. Using the last measurements, find κ . [4.5 points]
 7. Now place the pendulum with its rotation axis vertical³, and measure its oscillation period for several values of x (at least 5). With these measurements, find I_1 and ℓ . [4 points]

At this stage, after having found the system parameters, set the experimental apparatus as follows:

- pendulum rotation axis horizontal
- threaded rod as far as possible inside the pendulum
- pendulum as vertical as possible near equilibrium
- finally add the long hexagonal nut at the end of the threaded rod by screwing it a few turns (it can't go further than that)

In this way the pendulum may have two equilibrium positions, and the situation varies according to the position of the threaded rod, as you can also see from the generic graph shown in figure 5, of the potential energy as a function of the angle θ .

The doubling of the potential energy minimum in figure 5 illustrates a phenomenon known in mathematics as *bifurcation*; it is also related to the various kinds of symmetry breaking that are studied in particle physics and statistical mechanics.

³ In order to stabilize it in this position, you may reposition the stand brackets.

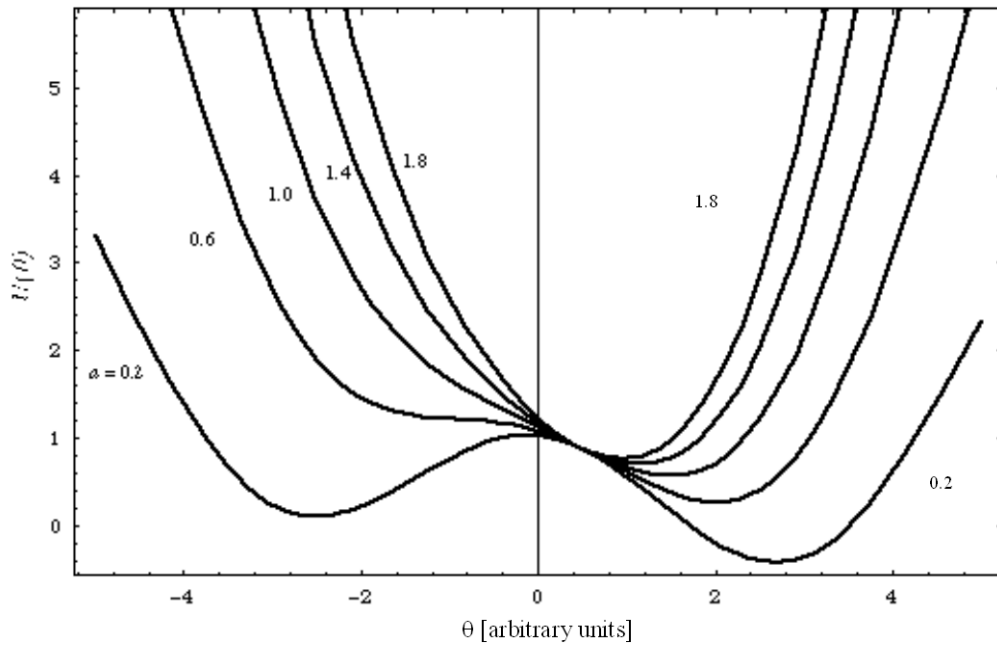

Figure 5: Graph of the function $U(\theta) = \frac{a}{2}(\theta - \theta_0)^2 + \cos \theta$ (which is proportional to the potential energy of this problem) as a function of θ , with $\theta_0 \neq 0$. The various curves correspond to different a values as labeled in the figure; smaller values of a ($a < 1$) correspond to the appearance of the bifurcation. In our case the parameter a is associated with the position x of the threaded rod.

We can now study this bifurcation by measuring the period of the small oscillations about the equilibrium position:

8. Plot the period⁴ T as a function of x . What kind of function is it? Is it increasing, decreasing or is it a more complex function? [2.5 points]

⁴ You may be able to observe two equilibrium positions, but one of them is more stable than the other (see figure 5). Report and plot the period for the more stable one.

Solution

1. At equilibrium the pressure p inside the vessel must be equal to the room pressure p_0 plus the pressure induced by the weight of the movable base: $p = p_0 + \frac{mg}{\pi r^2}$. This is true before and after irradiation. Initially the gas temperature is room temperature. Owing to the state equation of perfect gases, the initial gas volume V_1 is $V_1 = \frac{nRT_0}{p}$ (where R is the gas constant) and therefore the height

h_1 of the cylinder which is occupied by the gas is $h_1 = \frac{V_1}{\pi r^2} = \frac{nRT_0}{p_0 \pi r^2 + mg}$. After irradiation, this

height becomes $h_2 = h_1 + \Delta s$, and therefore the new temperature is

$$T_2 = T_0 \left(1 + \frac{\Delta s}{h_1} \right) = T_0 + \frac{\Delta s (p_0 \pi r^2 + mg)}{nR}.$$

Numerical values: $p = 102.32 \text{ kPa}$; $T_2 = 322 \text{ K} = 49^\circ\text{C}$

2. The mechanical work made by the gas against the plate weight is $mg\Delta s$ and against the room pressure is $p_0\pi r^2\Delta s$, therefore the total work is $L = (mg + p_0\pi r^2)\Delta s = 24.1 \text{ J}$
3. The internal energy, owing to the temperature variation, varies by an amount $\Delta U = nc_V(T_2 - T_0)$. The heat introduced into the system during the irradiation time Δt is $Q = \Delta U + L = nc_V \frac{T_0\Delta s}{h_1} + (mg + p_0\pi r^2)\Delta s = \Delta s (p_0\pi r^2 + mg) \left(\frac{c_V}{R} + 1 \right)$. This heat comes exclusively from the absorption of optical radiation and coincides therefore with the absorbed optical energy, $Q = 84 \text{ J}$.

The same result can also be obtained by considering an isobaric transformation and remembering the relationship between molecular heats:

$$Q = nc_p(T_2 - T_0) = n(c_V + R) \left[\frac{\Delta s (p_0\pi r^2 + mg)}{nR} \right] = \Delta s (p_0\pi r^2 + mg) \left(\frac{c_V}{R} + 1 \right)$$

4. Since the laser emits a constant power, the absorbed optical power is $W = \frac{Q}{\Delta t} = \left(\frac{c_V}{R} + 1 \right) \frac{\Delta s}{\Delta t} (p_0\pi r^2 + mg) = 8.4 \text{ W}$. The energy of each photon is hc/λ , and thus the number of photons absorbed per unit time is $\frac{W\lambda}{hc} = 2.2 \cdot 10^{19} \text{ s}^{-1}$

5. The potential energy change is equal to the mechanical work made against the plate weight, therefore the efficiency η of the energy transformation is

$$\frac{mg\Delta s}{Q} = \frac{1}{\left(1 + \frac{p_0 \pi r^2}{mg}\right) \left(1 + \frac{c_V}{R}\right)} = 2.8 \cdot 10^{-3} \approx 0.3\%$$

6. When the cylinder is rotated and its axis becomes horizontal, we have an adiabatic transformation where the pressure changes from p to p_0 , and the temperature changes therefore to a new value T_3 . The equation of the adiabatic transformation $pV^\gamma = \text{constant}$ may now be written in the form

$$T_3 = T_2 \left(\frac{p_0}{p}\right)^{\frac{\gamma-1}{\gamma}}, \text{ where } \gamma = \frac{c_p}{c_V} = \frac{c_V + R}{c_V} = 1 + \frac{R}{c_V} = 1.399. \text{ Finally } T_3 = 321 \text{ K} = 48^\circ\text{C}$$

Grading guidelines

- | | | |
|-----------|---------|--|
| 1. | 0.5 | Understanding the relationship between inner and outer pressure |
| | 0.7 | Proper use of the plate displacement |
| | 0.2+0.2 | Correct results for final pressure |
| | 0.2+0.2 | Correct results for final temperature |
| 2. | 0.6 | Understanding that the work is made both against plate weight and against atmospheric pressure |
| | 0.2+0.2 | Correct results for work |
| 3. | 1 | Correct approach |
| | 0.5 | Correct equation for heat |
| | 0.3 | Understanding that the absorbed optical energy equals heat |
| | 0.2 | Correct numerical result for optical energy |
| 4. | 0.2+0.2 | Correct results for optical power |
| | 0.5 | Einstein's equation |
| | 0.3+0.3 | Correct results for number of photons |
| 5. | 0.6 | Computation of the change in potential energy |
| | 0.2+0.2 | Correct results for efficiency |
| 6. | 0.8 | Understanding that the pressure returns to room value |
| | 0.4 | Understanding that there is an adiabatic transformation |
| | 0.4 | Equation of adiabatic transformation |
| | 0.5 | Derivation of γ from the relationship between specific heats |
| | 0.2+0.2 | Correct results for temperature |

For “correct results” two possible marks are given: the first one is for the analytical equation and the second one for the numerical value.

For the numerical values a full score cannot be given if the number of digits is incorrect (more than one digit more or less than those given in the solution) or if the units are incorrect or missing.

No bonus can be given for taking into account the gas weight

Solution

1. The contribution to \mathbf{B} given by each leg of the "V" has the same direction as that of a corresponding infinite wire and therefore - if the current proceeds as indicated by the arrow - the magnetic field is orthogonal to the wire plane taken as the x - y plane. If we use a right-handed reference frame as indicated in the figure, $\mathbf{B}(P)$ is along the positive z axis.



For symmetry reasons, the total field is twice that generated by each leg and has still the same direction.

- 2A. When $\alpha=\pi/2$ the "V" becomes a straight infinite wire. In this case the magnitude of the field $B(P)$ is known to be $B = \frac{i}{2\pi \epsilon_0 c^2 d} = \frac{i\mu_0}{2\pi d}$, and since $\tan(\pi/4)=1$, the factor k is $\frac{i\mu_0}{2\pi d}$.

The following solution is equally acceptable:

- 2B. If the student is aware of the equation $B = \frac{\mu_0 i}{4\pi} \frac{\cos\theta_1 - \cos\theta_2}{h}$ for a finite stretch of wire lying on a straight line at a distance h from point P and whose ends are seen from P under the angles θ_1 and θ_2 , he can find that the two legs of the "V" both produce fields $\frac{\mu_0 i}{4\pi} \frac{1 - \cos\alpha}{d \sin\alpha}$ and therefore the total

field is $B = \frac{i\mu_0}{2\pi d} \frac{1 - \cos\alpha}{\sin\alpha} = \frac{i\mu_0}{2\pi d} \tan\left(\frac{\alpha}{2}\right)$. This is a more complete solution since it also proves the angular dependence, but it is not required.

- 3A. In order to compute $\mathbf{B}(P^*)$ we may consider the "V" as equivalent to two crossed infinite wires (a and b in the following figure) plus another "V", symmetrical to the first one, shown in the figure as V', carrying the same current i , in opposite direction.

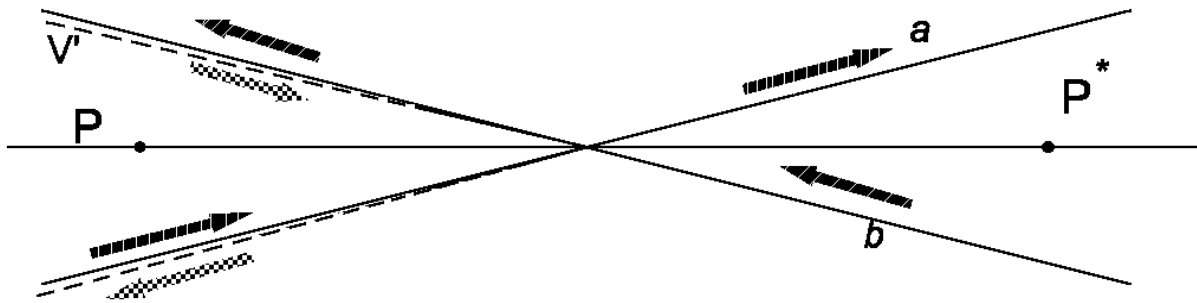

Then $B(P^*) = B_a(P^*) + B_b(P^*) + B_{V'}(P^*)$. The individual contributions are:

$$B_a(P^*) = B_b(P^*) = \frac{i\mu_0}{2\pi d \sin \alpha}, \text{ along the negative } z \text{ axis;}$$

$$B_{V'}(P^*) = \frac{i\mu_0}{2\pi d} \tan\left(\frac{\alpha}{2}\right), \text{ along the positive } z \text{ axis.}$$

Therefore we have $B(P^*) = \frac{i\mu_0}{2\pi d} \left[\frac{2}{\sin \alpha} - \tan\left(\frac{\alpha}{2}\right) \right] = k \left(\frac{1 + \cos \alpha}{\sin \alpha} \right) = k \cot\left(\frac{\alpha}{2}\right)$, and the field is along the negative z axis.

The following solutions are equally acceptable:

3B. The point P^* inside a "V" with half-span α can be treated as if it would be on the outside of a "V" with half-span $\pi - \alpha$ carrying the same current but in an opposite way, therefore the field is $B(P^*) = k \tan\left(\frac{\pi - \alpha}{2}\right) = k \tan\left(\frac{\pi}{2} - \frac{\alpha}{2}\right) = k \cot\left(\frac{\alpha}{2}\right)$; the direction is still that of the z axis but it is along the negative axis because the current flows in the opposite way as previously discussed.

3C. If the student follows the procedure outlined under 2B., he/she may also find the field value in P^* by the same method.

4. The mechanical moment \mathbf{M} acting on the magnetic needle placed in point P is given by $\mathbf{M} = \boldsymbol{\mu} \wedge \mathbf{B}$ (where the symbol \wedge is used for vector product). If the needle is displaced from its equilibrium position by an angle β small enough to approximate $\sin \beta$ with β , the angular momentum theorem gives $M = -\mu B \beta = \frac{dL}{dt} = I \frac{d^2 \beta}{dt^2}$, where there is a minus sign because the mechanical momentum is always opposite to the displacement from equilibrium. The period T of the small oscillations is therefore given by $T = \frac{2\pi}{\omega} = 2\pi \sqrt{\frac{I}{\mu B}}$.

Writing the differential equation, however, is not required: the student should recognise the same situation as with a harmonic oscillator.

5. If we label with subscript A the computations based on Ampère's interpretation, and with subscript BS those based on the other hypothesis by Biot and Savart, we have

$$B_A = \frac{i\mu_0}{2\pi d} \tan\left(\frac{\alpha}{2}\right) \quad B_{BS} = \frac{i\mu_0}{\pi^2 d} \alpha$$

$$T_A = 2\pi \sqrt{\frac{2\pi Id}{\mu_0 \mu_i \tan\left(\frac{\alpha}{2}\right)}} \quad T_{BS} = 2\pi \sqrt{\frac{\pi^2 Id}{\mu_0 \mu_i \alpha}}$$

$$\frac{T_A}{T_{BS}} = \sqrt{\frac{2\alpha}{\pi \tan\left(\frac{\alpha}{2}\right)}}$$

For $\alpha = \pi/2$ (maximum possible value) $T_A = T_{BS}$; and for $\alpha \rightarrow 0$ $T_A \rightarrow \frac{2}{\sqrt{\pi}} T_{BS} \approx 1.128 T_{BS}$. Since within this range $\frac{\tan(\alpha/2)}{\alpha/2}$ is a monotonically growing function of α , $\frac{T_A}{T_{BS}}$ is a monotonically decreasing function of α ; in an experiment it is therefore not possible to distinguish between the two interpretations if the value of α is larger than the value for which $T_A = 1.10 T_{BS}$ (10% difference), namely when $\tan\left(\frac{\alpha}{2}\right) = \frac{4}{1.21\pi} \frac{\alpha}{2} = 1.05 \frac{\alpha}{2}$. By looking into the trigonometry tables or using a calculator we see that this condition is well approximated when $\alpha/2 = 0.38$ rad; α must therefore be smaller than 0.77 rad $\approx 44^\circ$.

A graphical solution of the equation for α is acceptable but somewhat lengthy. A series development, on the contrary, is not acceptable.

Grading guidelines

1. 1 for recognising that each leg gives the same contribution
0.5 for a correct sketch
2. 0.5 for recognising that $\alpha=\pi/2$ for a straight wire, or for knowledge of the equation given in 2B.
0.25 for correct field equation (infinite or finite)
0.25 for value of k
3. 0.7 for recognising that the V is equivalent to two infinite wires plus another V
0.3 for correct field equation for an infinite wire
0.5 for correct result for the intensity of the required field
0.5 for correct field direction
alternatively
0.8 for describing the point as outside a V with $\pi-\alpha$ half-amplitude and opposite current
0.7 for correct analytic result
0.5 for correct field direction
alternatively
0.5 for correctly using equation under 2B
1 for correct analytic result
0.5 for correct field direction
4. 0.5 for correct equation for mechanical moment \mathbf{M}
0.5 for doing small angle approximation $\sin \beta \approx \beta$
1 for correct equation of motion, including sign, or for recognizing analogy with harmonic oscillator
0.5 for correct analytic result for T
5. 0.3 for correct formulas of the two periods
0.3 for recognising the limiting values for α
0.4 for correct ratio between the periods
1 for finding the relationship between α and tangent
0.5 for suitable approximate value of α
0.5 for final explicit limiting value of α

For the numerical values a full score cannot be given if the number of digits is incorrect (more than one digit more or less than those given in the solution) or if the units are incorrect or missing

Solution

- 1A. Assuming – as outlined in the text – that the orbit is circular, and relating the radial acceleration $\frac{V^2}{R}$ to the gravitational field $\frac{GM_S}{R^2}$ (where M_S is the solar mass) we obtain Jupiter's orbital speed $V = \sqrt{\frac{GM_S}{R}} \approx 1.306 \cdot 10^4$ m/s.

The following alternative solution is also acceptable:

- 1B. Since we treat Jupiter's motion as circular and uniform, $V = \omega R = \frac{2\pi R}{y_J}$, where y_J is the revolution period of Jupiter, which is given in the list of the general physical constants.

2. The two gravitational forces on the space probe are equal when

$$\frac{GMm}{\rho^2} = \frac{GM_S m}{(R - \rho)^2} \quad (2)$$

(where ρ is the distance from Jupiter and M is Jupiter's mass), whence

$$\sqrt{M} (R - \rho) = \rho \sqrt{M_S} \quad (3)$$

and

$$\rho = \frac{\sqrt{M}}{\sqrt{M_S} + \sqrt{M}} R = 0.02997R = 2.333 \cdot 10^{10} \text{ m} \quad (4)$$

and therefore the two gravitational attractions are equal at a distance of about 23.3 million kilometers from Jupiter (about 334 Jupiter radii).

3. With a simple Galilean transformation we find that the velocity components of the probe in Jupiter's reference frame are

$$\begin{cases} v'_x = V \\ v'_y = v_0 \end{cases}$$

and therefore - in Jupiter's reference frame – the probe travels with an angle $\theta_0 = \arctan \frac{v_0}{V}$ with

respect to the x axis and its speed is $v' = \sqrt{v_0^2 + V^2}$ (we also note that $\cos \theta_0 = \frac{V}{\sqrt{v_0^2 + V^2}} = \frac{V}{v'}$)

and $\sin \theta_0 = \frac{v_0}{\sqrt{v_0^2 + V^2}} = \frac{v_0}{v'}$).

Using the given values we obtain $\theta_0 = 0.653 \text{ rad} \approx 37.4^\circ$ and $v' = 1.65 \cdot 10^4 \text{ m/s}$.

4. Since the probe trajectory can be described only approximately as the result of a two-body gravitational interaction (we should also take into account the interaction with the Sun and other planets) we assume a large but not infinite distance from Jupiter and we approximate the total energy in Jupiter's reference frame as the probe's kinetic energy at that distance:

$$E \approx \frac{1}{2} m v'^2 \tag{5}$$

The corresponding numerical value is $E = 112 \text{ GJ}$.

5. Equation (1) shows that the radial distance becomes infinite, and its reciprocal equals zero, when

$$1 + \sqrt{1 + \frac{2E v'^2 b^2}{G^2 M^2 m}} \cos \theta = 0 \tag{7}$$

namely when

$$\cos \theta = - \frac{1}{\sqrt{1 + \frac{2E v'^2 b^2}{G^2 M^2 m}}} \tag{8}$$

We should also note that the radial distance can't be negative, and therefore its acceptable values are those satisfying the equation

$$1 + \sqrt{1 + \frac{2E v'^2 b^2}{G^2 M^2 m}} \cos \theta \geq 0 \tag{9}$$

or

$$\cos \theta \geq - \frac{1}{\sqrt{1 + \frac{2E v'^2 b^2}{G^2 M^2 m}}} \tag{10}$$

The solutions for the limiting case of eq. (10) (i.e. when the equal sign applies) are:

$$\theta_{\pm} = \pm \arccos \left[- \left(1 + \frac{2E v'^2 b^2}{G^2 M^2 m} \right)^{-1/2} \right] = \pm \left(\pi - \arccos \frac{1}{\sqrt{1 + \frac{2E v'^2 b^2}{G^2 M^2 m}}} \right) \tag{11}$$

and therefore the angle $\Delta\theta$ (shown in figure 2) between the two hyperbola asymptotes is given by:

$$\begin{aligned}\Delta\theta &= (\theta_+ - \theta_-) - \pi \\ &= \pi - 2 \arccos \frac{1}{\sqrt{1 + \frac{2Ev^2 b^2}{G^2 M^2 m}}} \\ &= \pi - 2 \arccos \frac{1}{\sqrt{1 + \frac{v'^4 b^2}{G^2 M^2}}}\end{aligned}\quad (12)$$

In the last line, we used the value of the total energy as computed in the previous section.

6. The angular deviation is a monotonically decreasing function of the impact parameter, whence the deviation has a maximum when the impact parameter has a minimum. From the discussion in the previous section we easily see that the point of nearest approach is when $\theta = 0$, and in this case the minimum distance between probe and planet center is easily obtained from eq. (1):

$$r_{\min} = \frac{v'^2 b^2}{GM} \left(1 + \sqrt{1 + \frac{v'^4 b^2}{G^2 M^2}} \right)^{-1} \quad (13)$$

By inverting equation (13) we obtain the impact parameter

$$b = \sqrt{r_{\min}^2 + \frac{2GM}{v'^2} r_{\min}} \quad (14)$$

We may note that this result can alternatively be obtained by considering that, due to the conservation of angular momentum, we have

$$L = mv'b = mv'_{\min} r_{\min}$$

where we introduced the speed corresponding to the nearest approach. In addition, the conservation of energy gives

$$E = \frac{1}{2}mv'^2 = \frac{1}{2}mv'_{\min}^2 - \frac{GMm}{r_{\min}}$$

and by combining these two equations we obtain equation (14) again.

The impact parameter is an increasing function of the distance of nearest approach; therefore, if the probe cannot approach Jupiter's surface by less than two radii (and thus $r_{\min} = 3R_B$, where R_B is Jupiter's body radius), the minimum acceptable value of the impact parameter is

$$b_{\min} = \sqrt{9R_B^2 + \frac{6GM}{v'^2} R_B} \quad (15)$$

From this equation we finally obtain the maximum possible deviation:

$$\Delta\theta_{\max} = \pi - 2 \arccos \frac{1}{\sqrt{1 + \frac{v'^4 b_{\min}^2}{G^2 M^2}}} = \pi - 2 \arccos \frac{1}{\sqrt{1 + \frac{v'^4}{G^2 M^2} \left(9R_B^2 + \frac{6GM}{v'^2} R_B \right)}} \quad (16)$$

and by using the numerical values we computed before we obtain:

$$b_{\min} = 4.90 \cdot 10^8 \text{ m} \approx 7.0 R_B \quad \text{and} \quad \Delta\theta_{\max} = 1.526 \text{ rad} \approx 87.4^\circ$$

7. The final direction of motion with respect to the x axis in Jupiter's reference frame is given by the initial angle plus the deviation angle, thus $\theta_0 + \Delta\theta$ if the probe passes behind the planet. The final velocity components in Jupiter's reference frame are therefore:

$$\begin{cases} v'_x = v' \cos(\theta_0 + \Delta\theta) \\ v'_y = v' \sin(\theta_0 + \Delta\theta) \end{cases}$$

whereas in the Sun reference frame they are

$$\begin{cases} v''_x = v' \cos(\theta_0 + \Delta\theta) - V \\ v''_y = v' \sin(\theta_0 + \Delta\theta) \end{cases}$$

Therefore the final probe speed in the Sun reference frame is

$$\begin{aligned}v'' &= \sqrt{(v' \cos(\theta_0 + \Delta\theta) - V)^2 + (v' \sin(\theta_0 + \Delta\theta))^2} \\&= \sqrt{v_0^2 + 2V^2 - 2v'V \cos(\theta_0 + \Delta\theta)} \\&= \sqrt{v_0^2 + 2V^2 - 2v'V(\cos \theta_0 \cos \Delta\theta - \sin \theta_0 \sin \Delta\theta)} \quad (17) \\&= \sqrt{v_0^2 + 2V^2 - 2V(V \cos \Delta\theta - v_0 \sin \Delta\theta)} \\&= \sqrt{v_0(v_0 + 2V \sin \Delta\theta) + 2V^2(1 - \cos \Delta\theta)}\end{aligned}$$

8. Using the value of the maximum possible angular deviation, the numerical result is $v'' = 2.62 \cdot 10^4$ m/s.

Grading guidelines

- | | | |
|-----------|---------|--|
| 1. | 0.4 | Law of gravitation, or law of circular uniform motion |
| | 0.4 | Correct approach |
| | 0.4+0.3 | Correct results for velocity of Jupiter |
| 2. | 0.3 | Correct approach |
| | 0.4+0.3 | Correct results for distance from Jupiter |
| 3. | 1 | Correct transformation between reference frames |
| | 0.3+0.2 | Correct results for probe speed in Jupiter reference frame |
| | 0.3+0.2 | Correct results for probe angle |
| 4. | 0.8 | Understanding how to handle the potential energy at infinity |
| | 0.2 | Numerical result for kinetic energy |
| 5. | 0.6 | Correct approach |
| | 0.6 | Equation for the orientation of the asymptotes |
| | 0.8 | Equation for the probe deflection angle |
| 6. | 0.3+0.2 | Correct results for minimum impact parameter |
| | 0.3+0.2 | Correct results for maximum deflection angle |
| 7. | 0.5 | Equation for velocity components in the Sun reference frame |
| | 0.5 | Equation for speed as a function of angular deflection |
| 8. | 0.5 | Numerical result for final speed |

For “correct results” two possible marks are given: the first one is for the analytical equation and the second one for the numerical value.

For the numerical values a full score cannot be given if the number of digits is incorrect (more than one digit more or less than those given in the solution) or if the units are incorrect or missing.

Solution

The numerical values given in the text are those obtained in a preliminary test performed by a student of the University of Bologna¹, and are reported here only as a guide to the evaluation of the student solutions.

1. and 2. The distance from the center of mass to the rotation axis is:

$$R(x) = \frac{M_1 R_1 + M_2 (x - \ell/2)}{M_1 + M_2} \quad (1)$$

and therefore, if we measure the position of the center of mass² as a function of x we obtain a relationship between the system parameters, and by a linear fit of eq. (1) we obtain an angular coefficient equal to $M_2/(M_1 + M_2)$, and from these equations, making use of the given total mass $M_1 + M_2 = 41.0 \text{ g} \pm 0.1 \text{ g}$, we obtain M_1 and M_2 . The following table shows some results obtained in the test run.

n	x [mm]	$R(x)$ [mm]
1	204±1	76±1
2	220±1	83±1
3	236±1	89±1
4	254±1	95±1
5	269±1	101±1
6	287±1	107±1
7	302±1	113±1
8	321±1	119±1

Figure 6 shows the data concerning the position of the pendulum's center of mass together with a best fit straight line: the estimated error on the length measurements is now 1 mm and we treat it as a Gaussian error. Notice that both the dependent variable $R(x)$ and the independent variable x are affected by the experimental uncertainty, however we decide to neglect the uncertainty on x , since it is smaller than 1%. The coefficients a and b in $R(x) = ax+b$ are

$$a = 0.366 \pm 0.009$$

$$b = 2 \text{ mm} \pm 2 \text{ mm}$$

¹ Mr. Maurizio Recchi.

² This can easily be done by balancing the pendulum, e.g. on the T-shaped rod provided.

(therefore b is compatible with 0)

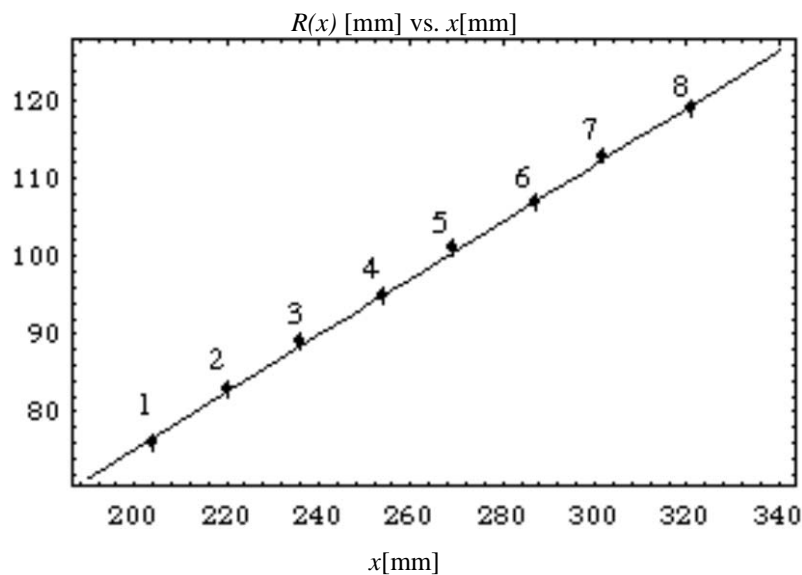

Figure 6: Graph of the position of the pendulum's center of mass (with respect to the rotation axis) as a function of the variable x . The numbering of the data points corresponds to that mentioned in the main text. The estimated error is compatible with the fluctuations of the measured data.

For computing the masses only the a value is needed; using the total pendulum mass we find:

$$M_1 = 26.1 \pm 0.4 \text{ g}$$

$$M_2 = 15.0 \text{ g} \pm 0.4 \text{ g}$$

Even though many non-programmable pocket calculators can carry out a linear regression, it is likely that many students will be unable to do such an analysis, and in particular they may be unable to estimate the uncertainty of the fit parameters even if their pocket calculators provide a linear regression mode. It is also acceptable to find a and b using several pairs of measurements and finally computing a weighted average of the results. For each pair of measurements a and b are given by

$$a = \frac{y_2 - y_1}{x_2 - x_1} \tag{2}$$

$$b = y_2 - ax_2$$

and the parameter uncertainties (assuming them gaussian) by

$$\Delta a = a \sqrt{\frac{\Delta x_1^2 + \Delta x_2^2}{(x_1 - x_2)^2} + \frac{\Delta y_1^2 + \Delta y_2^2}{(y_1 - y_2)^2}} \quad (3)$$

$$\Delta b = \sqrt{\Delta y_2^2 + a^2 x_2^2 \left(\frac{\Delta x_2^2}{x_2^2} + \frac{\Delta a^2}{a^2} \right)}$$

In order to calculate (2) and (3) the data can be paired with a scheme like {1,5},{2,6},{3,7},{4,8}, where "far" points are coupled in order to minimize the error on each pair.

There may be other alternative and equally acceptable approaches: they should all be considered valid if the order of magnitude of the estimated uncertainty is correct.

3. The pendulum's total moment of inertia is the sum of the moments of its two parts, and from figure 3 we see that

$$I(x) = I_1 + I_2(x) = M_2 x^2 - M_2 \ell x + \left(I_1 + \frac{M_2}{3} \ell^2 \right) \quad (4)$$

4. The pendulum's equation of motion is

$$I(x) \frac{d^2 \theta}{dt^2} = -\kappa(\theta - \theta_0) \quad (5)$$

if the rotation axis is vertical, while it's

$$I(x) \frac{d^2 \theta}{dt^2} = -\kappa(\theta - \theta_0) + (M_1 + M_2)gR(x)\sin \theta \quad (6)$$

if the rotation axis is horizontal.

5. and 6. When the system is at rest in an equilibrium position, the angular acceleration is zero and therefore the equilibrium positions θ_e can be found by solving the equation

$$-\kappa(\theta_e - \theta_0) + (M_1 + M_2)gR(x)\sin \theta_e = 0 \quad (7)$$

If the value x_i corresponds to the equilibrium angle $\theta_{e,i}$, and if we define the quantity (that can be computed from the experimental data) $y_i = (M_1 + M_2)gR(x_i)\sin \theta_{e,i}$, then eq. (7) may be written as

$$y_i = \kappa \theta_{e,i} - \kappa \theta_0 \quad (8)$$

and therefore the quantities κ and $\kappa\theta_0$ can be found with a linear fit. The following table shows several data collected in a trial run according to the geometry shown in figure 7.

n	x [mm]	h [mm]	$\sin\theta_e = h/x$	θ_e	y [N· μ m]
1	204 \pm 1	40 \pm 1	0.196 \pm 0.005	0.197 \pm 0.005	6.1 \pm 0.3
2	220 \pm 1	62 \pm 1	0.282 \pm 0.005	0.286 \pm 0.005	9.4 \pm 0.4
3	238 \pm 1	75 \pm 1	0.315 \pm 0.004	0.321 \pm 0.005	11.3 \pm 0.5
4	255 \pm 1	89 \pm 1	0.349 \pm 0.004	0.357 \pm 0.004	13.4 \pm 0.5
5	270 \pm 1	109 \pm 1	0.404 \pm 0.004	0.416 \pm 0.004	16.4 \pm 0.6
6	286 \pm 1	131 \pm 1	0.458 \pm 0.004	0.476 \pm 0.004	19.7 \pm 0.7
7	307 \pm 1	162 \pm 1	0.528 \pm 0.004	0.556 \pm 0.004	24.3 \pm 0.8
8	321 \pm 1	188 \pm 1	0.586 \pm 0.004	0.626 \pm 0.004	28.2 \pm 0.9

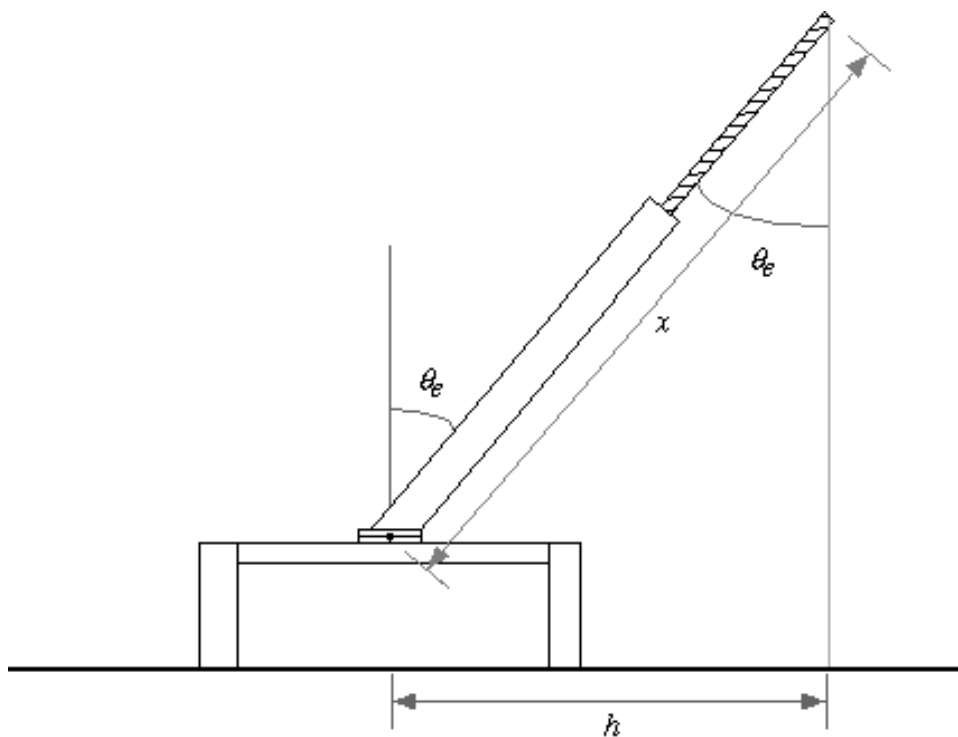

Figure 7: Geometry of the measurements taken for finding the angle.

We see that not only the dependent but also the independent variable is affected by a measurement uncertainty, but the relative uncertainty on θ_e is much smaller than the relative uncertainty on y and we neglect it. We obtain from such data (neglecting the first data point, see figure 8):

$$\kappa = 0.055 \text{ N}\cdot\text{m}\cdot\text{rad}^{-1} \pm 0.001 \text{ N}\cdot\text{m}\cdot\text{rad}^{-1}$$

$$\kappa\theta_0 = -0.0063 \text{ N}\cdot\text{m} \pm 0.0008 \text{ N}\cdot\text{m}$$

Clearly in this case only the determination of the torsion coefficient κ is interesting. The fit of the experimental data is shown in figure 8.

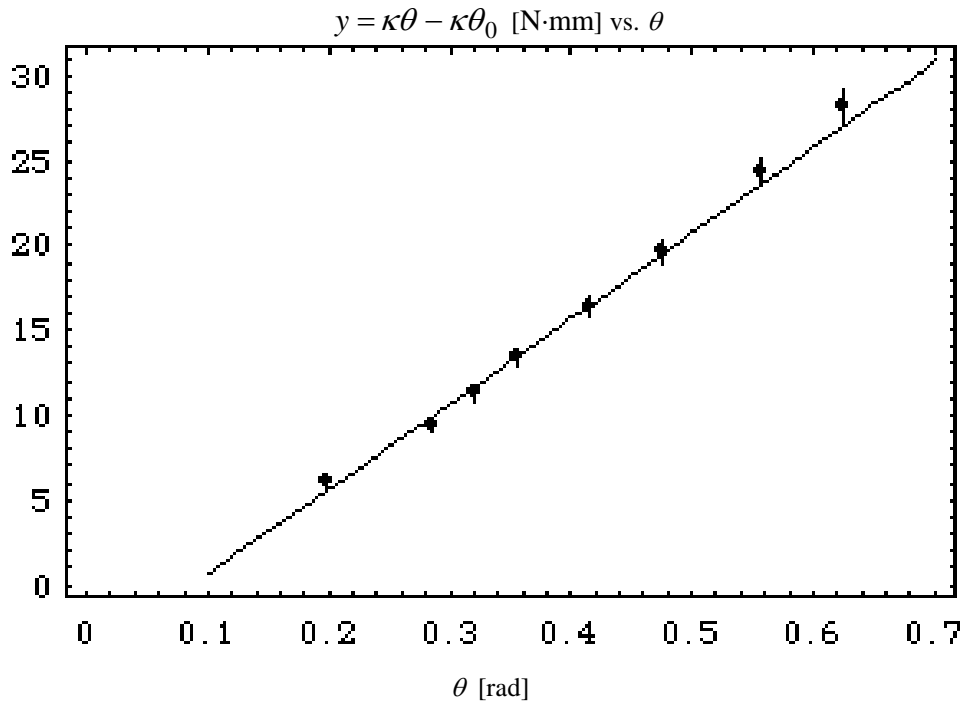

Figure 8: Fit of eq. (8) as a function of θ . In this case the estimated error is again compatible with the experimental data fluctuations. However the data points show a visible deviation from straightness which may be due to an error in the first measurement (the one at lowest θ).

7. The moment of inertia can be found experimentally using the pendulum with its rotation axis vertical and recalling eq. (5); from this equation we see that the pendulum oscillates with angular frequency $\omega(x) = \sqrt{\frac{\kappa}{I(x)}}$ and therefore

$$I(x) = \frac{\kappa T^2(x)}{4\pi^2} \tag{9}$$

where T is the measured oscillation period. Using eq. (9) we see that eq. (4) can be rewritten as

$$\frac{\kappa}{4\pi^2} T^2(x) - M_2 x^2 = -M_2 \ell x + \left(I_1 + \frac{M_2}{3} \ell^2 \right) \tag{10}$$

The left-hand side in eq. (10) is known experimentally, and therefore with a simple linear fit we can find the coefficients $M_2\ell$ and $\left(I_1 + \frac{M_2}{3}\ell^2\right)$, as we did before. The experimental data are in this case:

n	x [mm]	T [s]
1	204±1	0.502±0.002
2	215±1	0.528±0.002
3	231±1	0.562±0.002
4	258±1	0.628±0.002
5	290±1	0.708±0.002
6	321±1	0.790±0.002

The low uncertainty on T has been obtained measuring the total time required for 50 full periods.

Using the previous data and another linear fit, we find

$$\ell = 230 \text{ mm} \pm 20 \text{ mm}$$

$$I_1 = 1.7 \cdot 10^{-4} \text{ kg}\cdot\text{m}^2 \pm 0.7 \cdot 10^{-4} \text{ kg}\cdot\text{m}^2$$

and the fit of the experimental data is shown in figure 9.

$$y = \frac{\kappa}{4\pi^2} T^2(x) - M_2 x^2 \text{ [kg}\cdot\text{m}^2] \text{ vs. } x \text{ [m]}$$

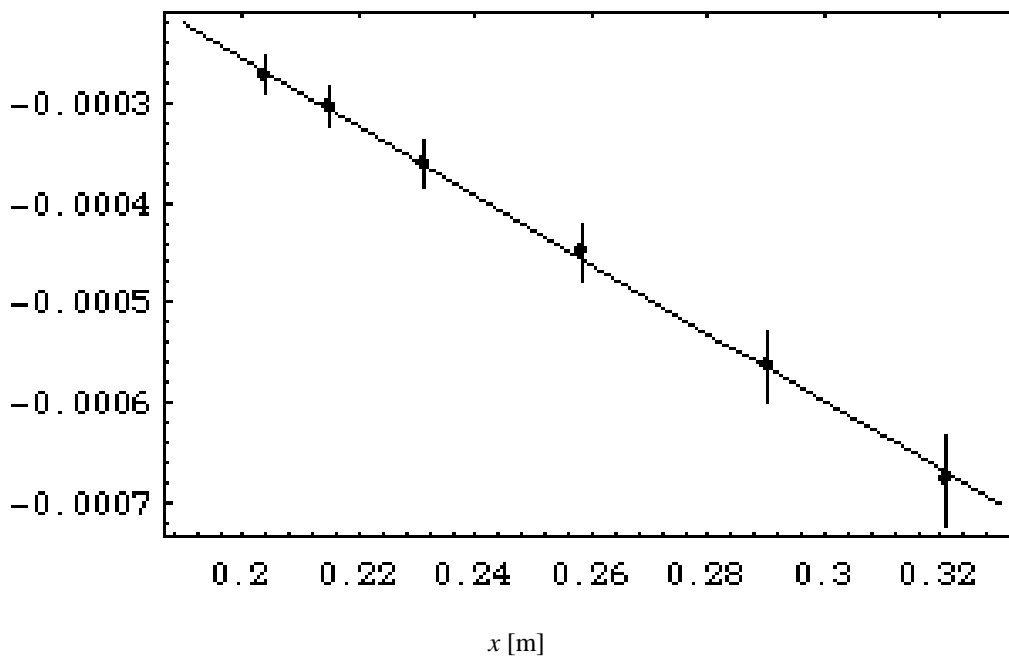

Figure 9: Fit of eq. (10) as a function of x . In this case the estimated error is again compatible with the experimental data fluctuations.

8. Although in this case the period T is a complicated function of x , its graph is simple, and it is shown in figure 10, along with the test experimental data.

The required answer is that there is a single local maximum.

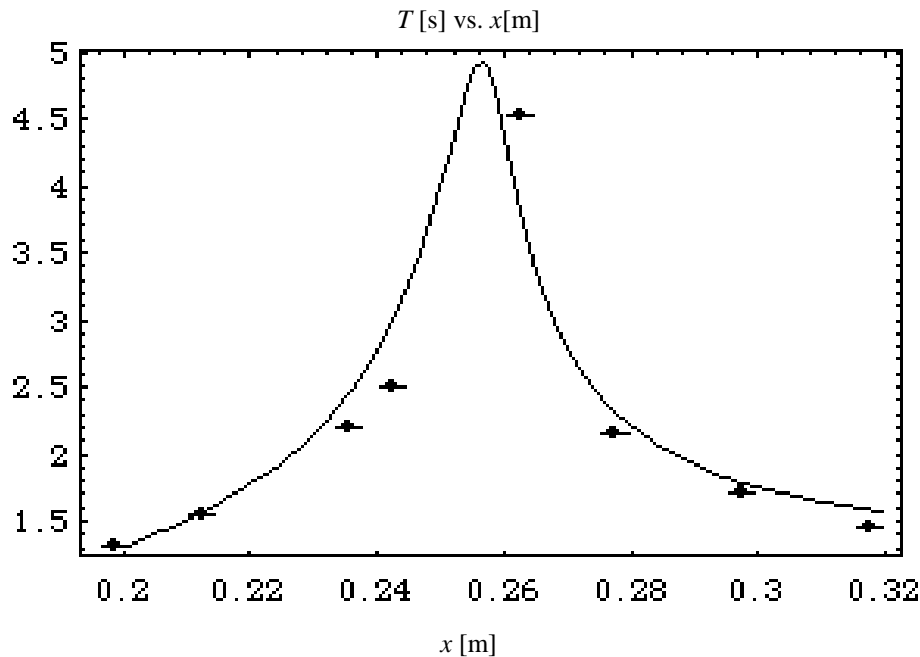

Figure 10: The period T of the pendulum with horizontal axis as a function of x . In addition to the experimental points the figure shows the result of a theoretical calculation of the period in which the following values have been assumed: $g = 9.81 \text{ m/s}^2$; $\kappa = 0.056 \text{ N}\cdot\text{m/rad}$; $M_1 = 0.0261 \text{ kg}$; $M_2 = 0.0150 \text{ kg}$; $M_3 = 0.00664 \text{ kg}$; $I_1 = 1.0\cdot 10^{-4} \text{ kg}\cdot\text{m}^2$; $\ell = 0.21 \text{ m}$; $\ell_3 = 0.025 \text{ m}$; $a = 0.365$; $b = 0.0022 \text{ m}$ (so that the position of the center of mass - excluding the final nut of length ℓ_3 - is $R(x) = ax+b$); these are the central measured values, with the exception of κ , I_1 and ℓ which are taken one standard deviation off their central value. Also, the value $\theta_0 = 0.030 \text{ rad} \approx 1.7^\circ$ has been assumed. Even though the theoretical curve is the result of just a few trial calculations using the measured values (\pm one standard deviation) and is not a true fit, it is quite close to the measured data.

Theoretical Problem 1

Part A

A bungee jumper is attached to one end of a long elastic rope. The other end of the elastic rope is fixed to a high bridge. The jumper steps off the bridge and falls, from rest, towards the river below. He does not hit the water. The mass of the jumper is m , the unstretched length of the rope is L , the rope has a force constant (force to produce 1 m extension) of k and the gravitational field strength is g .

You may assume that

- the jumper can be regarded as a point mass m attached to the end of the rope,
- the mass of the rope is negligible compared to m ,
- the rope obeys Hooke's law,
- air resistance can be ignored throughout the fall of the jumper.

Obtain expressions for the following and insert on the answer sheet:

- the distance y dropped by the jumper before coming instantaneously to rest for the first time,
- the maximum speed v attained by the jumper during this drop,
- the time t taken during the drop before coming to rest for the first time.

Part B

A heat engine operates between two identical bodies at different temperatures T_A and T_B ($T_A > T_B$), with each body having mass m and constant specific heat capacity s . The bodies remain at constant pressure and undergo no change of phase.

1. Showing full working, obtain an expression for the final temperature T_0 attained by the two bodies A and B if the heat engine extracts from the system the maximum amount of mechanical work that is theoretically possible.

Write your expression for the final temperature T_0 on the answer sheet.

2. Hence, obtain and write on the answer sheet an expression for this maximum amount of work available.

The heat engine operates between two tanks of water each of volume 2.50 m^3 . One tank is at 350 K and the other is at 300 K .

3. Calculate the maximum amount of mechanical energy obtainable. Insert the value on the answer sheet.

Specific heat capacity of water = $4.19 \times 10^3 \text{ J kg}^{-1} \text{ K}^{-1}$

Density of water = $1.00 \times 10^3 \text{ kg m}^{-3}$

Part C

It is assumed that when the earth was formed the isotopes ^{238}U and ^{235}U were present but not their decay products. The decays of ^{238}U and ^{235}U are used to establish the age of the earth, T .

- a. The isotope ^{238}U decays with a half-life of 4.50×10^9 years. The decay products in the resulting radioactive series have half-lives short compared to this; to a first approximation their existence can be ignored. The decay series terminates in the stable lead isotope ^{206}Pb .

Obtain and insert on the answer sheet an expression for the number of ^{206}Pb atoms, denoted ^{206}Pb , produced by radioactive decay with time t , in terms of the present number of ^{238}U atoms, denoted ^{238}U , and the half-life time of ^{238}U . (You may find it helpful to work in units of 10^9 years.)

- b. Similarly, ^{235}U decays with a half-life of 0.710×10^9 years through a series of shorter half-life products to give the stable isotope ^{207}Pb .

.....

Write down on the answer sheet an equation relating λ to T and the half-life of ^{238}U .

- c. A uranium ore, mixed with a lead ore, is analysed with a mass spectrometer. The relative concentrations of the three lead isotopes ^{204}Pb , ^{206}Pb and ^{207}Pb are measured and the number of atoms are found to be in the ratios 1.00 : 29.6 : 22.6 respectively. The isotope ^{204}Pb is used for reference as it is not of radioactive origin. Analysing a pure lead ore gives ratios of 1.00 : 17.9 : 15.5.

Given that the ratio $^{238}\text{N} : ^{235}\text{N}$ is 137 : 1, derive and insert on the answer sheet an equation involving T .

- d. Assume that T is much greater than the half lives of both uranium isotopes and hence obtain an approximate value for T .
- e. This approximate value is clearly not significantly greater than the longer half life, but can be used to obtain a much more accurate value for T . Hence, or otherwise, estimate a value for the age of the earth correct to within 2%.

Part D

Charge Q is uniformly distributed *in vacuo* throughout a spherical volume of radius R .

- a. Derive expressions for the electric field strength at distance r from the centre of the sphere for $r \leq R$ and $r > R$.
- b. Obtain an expression for the total electric energy associated with this distribution of charge.

Insert your answers to (a) and (b) on the answer sheet.

Part E

A circular ring of thin copper wire is set rotating about a vertical diameter at a point within the Earth's magnetic field. The magnetic flux density of the Earth's magnetic field at this point is $44.5 \mu\text{T}$ directed at an angle of 64° below the horizontal. Given that the density of copper is $8.90 \times 10^3 \text{ kg m}^{-3}$ and its resistivity is $1.70 \times 10^{-8} \Omega \text{ m}$, calculate how long it will take for the angular velocity of the ring to halve. Show the steps of your working and insert the value of the time on the answer sheet. This time is much longer than the time for one revolution.

You may assume that the frictional effects of the supports and air are negligible, and for the purposes of this question you should ignore self-inductance effects, although these would not be negligible.

Theoretical Problem 2

- a. A cathode ray tube (CRT), consisting of an electron gun and a screen, is placed within a uniform constant magnetic field of magnitude B such that the magnetic field is parallel to the beam axis of the gun, as shown in figure 2.1.

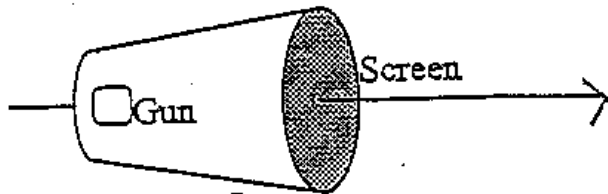

Figure 2.1

The electron beam emerges from the anode of the electron gun on the axis, but with a divergence of up to 5° from the axis, as illustrated in figure 2.2. In general a diffuse spot is produced on the screen, but for certain values of the magnetic field a sharply focused spot is obtained.

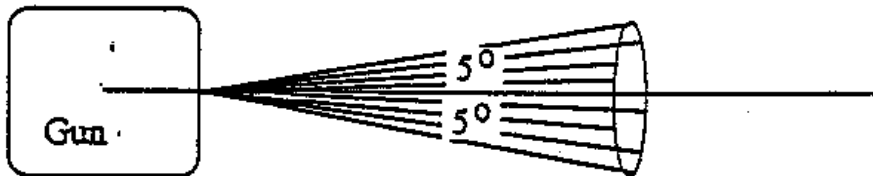

Figure 2.2

By considering the motion of an electron initially moving at an angle β (where $0 \leq \beta \leq 5^\circ$) to the axis as it leaves the electron gun, and considering the components of its motion parallel and perpendicular to the axis, derive an expression for the charge to mass ratio e/m for the electron in terms of the following quantities:

- the smallest magnetic field for which a focused spot is obtained,
- the accelerating potential difference across the electron gun V (note that $V < 2 \text{ kV}$),
- D , the distance between the anode and the screen.

Write your expression in the box provided in section 2a of the answer sheet.

- b. Consider another method of evaluating the charge to mass ratio of the electron. The arrangement is shown from a side view and in plan view (from above) in figure 2.3, with the direction of the magnetic field marked \mathbf{B} . Within this uniform magnetic field \mathbf{B} are placed two brass circular plates of radius ρ which are separated by a very small distance t . A potential difference V is maintained between them. The plates are mutually parallel and co-axial, however their axis is perpendicular to the magnetic field. A photographic film, covers the inside of the curved surface of a cylinder of radius $\rho + s$, which is held co-axial with the plates. In other words, the film is at a radial distance s from the edges of the plates. The entire arrangement is placed *in vacuo*. Note that t is very much smaller than both s and ρ .

A point source of β particles, which emits the β particles uniformly in all directions with a range of velocities, is placed between the centres of the plates, and the *same piece of film* is exposed under three different conditions:

- firstly with $B = 0$, and $V = 0$,
- secondly with $B = B_0$, and $V = V_0$, and
- thirdly with $B = -B_0$, and $V = -V_0$;

where V_0 and B_0 are positive constants. Please note that the upper plate is positively charged when $V > 0$ (negative when $V < 0$), and that the magnetic field is in the direction defined by figure 2.5 when $B > 0$ (in the opposite direction when $B < 0$). For this part you may assume the gap is negligibly small.

Two regions of the film are labelled A and B on figure 2.3. After exposure and development, a sketch of one of these regions is given in figure 2.4.

From which region was this piece taken (on your answer sheet write A or B)? Justify your answer by showing the directions of the forces acting on the electron.

- c. After exposure and development, a sketch of the film is given in figure 2.4. Measurements are made of the separation of the two outermost traces with a microscope, and this distance (y) is also indicated for one particular angle on figure 2.4. The results are given in the table below, the angle ϕ being defined in figure 2.3 as the angle between the magnetic field and a line joining the centre of the plates to the point on the film.

Angle to field /degrees	ϕ	90	60	50	40	30	23
Separation /mm	y	17.4	12.7	9.7	6.4	3.3	End of trace

Numerical values of the system parameters are given below:

$$B_0 = 6.91 \text{ mT } V_0 = 580 \text{ V } t = 0.80 \text{ mm } s = 41.0 \text{ mm}$$

In addition, you may take the speed of light in vacuum to be $3.00 \times 10^8 \text{ m s}^{-1}$, and the rest mass of the electron to be $9.11 \times 10^{-31} \text{ kg}$.

Determine the maximum β particle kinetic energy observed.

Write the maximum kinetic energy as a numerical result in eV in the box on the answer sheet, section 2c.

- d. Using the information given in part (c), obtain a value for the charge to rest mass ratio of the electron. This should be done by plotting an appropriate graph on the paper provided.

Indicate *algebraically* the quantities being plotted on the horizontal and vertical axes both on the graph itself *and* on the answer sheet in the boxes provided in section 2d.

Write your value for the charge to mass ratio of the electron in the box provided on the answer sheet, section 2d.

Please note that the answer you obtain may not agree with the accepted value because of a systematic error in the observations.

Additional Figures

Figure 2.3

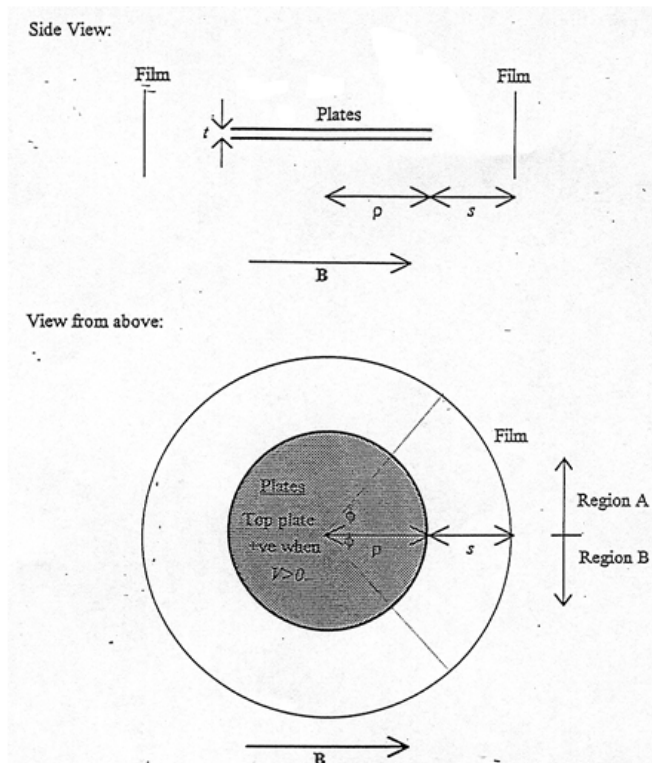
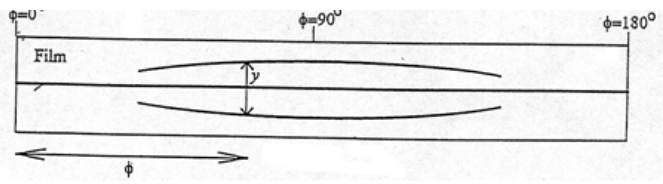

Figure 2.4



Theoretical Problem 3

Part A

This part is concerned with the difficulties of detecting gravitational waves generated by astronomical events. It should be realised that the explosion of a distant supernova may produce fluctuations in the gravitational field strength at the surface of the Earth of about $10^{-19} \text{ N kg}^{-1}$. A model for a gravitational wave detector (see figure 3.1) consists of two metal rods each 1m long, held at right angles to each other. One end of each rod is polished optically flat and the other end is held rigidly. The position of one rod is adjusted so there is a minimum signal received from the photocell (see figure 3.1).

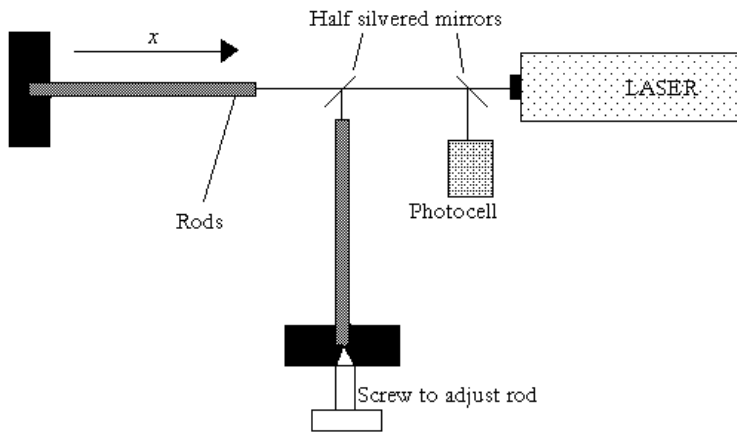

Figure 3.1

Figure 3.1

The rods are given a short sharp longitudinal impulse by a piezoelectric device. As a result the free ends of the rods oscillate with a longitudinal displacement Δx_f , where

$$\Delta x_f = ae^{-\lambda t} \cos(\omega t + \phi),$$

and a , m , ω and λ are constants.

- If the amplitude of the motion is reduced by 20% during a 50s interval determine a value for m .
- Given that longitudinal wave velocity, $v = \sqrt{E/\rho}$, determine also the lowest value for ω , given that the rods are made of aluminium with a density (ρ) of 2700 kg m^{-3} and a Young modulus (E) of $7.1 \times 10^{10} \text{ Pa}$.
- It is impossible to make the rods exactly the same length so the photocell signal has a beat frequency of 0.005 Hz. What is the difference in length of the rods?
- For the rod of length l , derive an algebraic expression for the change in length, Δl , due to a change, Δg , in the gravitational field strength, g , in terms of l and other constants of the rod material. The response of the detector to this change takes place in the direction of one of the rods.
- The light produced by the laser is monochromatic with a wavelength of 656nm. If the minimum fringe shift that can be detected is 10^{-4} of the wavelength of the laser, what is the minimum value of l necessary if such a system were to be capable of detecting variations in g of $10^{-19} \text{ N kg}^{-1}$?

Part B

This part is concerned with the effect of a gravitational field on the propagation of light in space.

(a) A photon emitted from the surface of the Sun (mass M , radius R) is red-shifted. By assuming a rest-mass equivalent for the photon energy, apply Newtonian gravitational theory to show that the effective (or measured) frequency of the photon at infinity is reduced (red-shifted) by the factor $(1 - GM/Rc^2)$.

(b) A reduction of the photon's frequency is equivalent to an increase in its time period, or, using the photon as a standard clock, a dilation of time. In addition, it may be shown that a time dilation is always accompanied by a contraction in the unit of length by the same factor.

We will now try to study the effect that this has on the propagation of light near the Sun. Let us first define an effective refractive index n_r at a point r from the centre of the Sun. Let

$$n_r = \frac{c}{c_r},$$

where c is the speed of light as measured by a co-ordinate system far away from the Sun's gravitational influence ($r \rightarrow \infty$), and c_r is the speed of light as measured by a co-ordinate system at a distance r from the centre of the Sun.

Show that n_r may be approximated to:

$$n_r = 1 + \frac{aGM}{rc^2},$$

for small GM/rc^2 , where a is a constant that you determine.

(c) Using this expression for n_r , calculate in radians the deflection of a light ray from its straight path as it passes the edge of the Sun.

Data:

Gravitational constant, $G = 6.67 \times 10^{-11} \text{ N m}^2 \text{ kg}^{-2}$.

Mass of Sun, $M = 1.99 \times 10^{30} \text{ kg}$.

Radius of Sun, $R = 6.95 \times 10^8 \text{ m}$.

Velocity of light, $c = 3.00 \times 10^8 \text{ m s}^{-1}$.

You may also need the following integral

$$\int_{-\infty}^{+\infty} \frac{dx}{(x^2 + a^2)^{3/2}} = \frac{2}{a^2}.$$

DRAFT COPY

31st International Physics Olympiad

Leicester, U.K.

Experimental Competition

Wednesday, July 12th, 2000

Please read this first:

1. The time available is 2 ½ hours for each of the 2 experimental questions. Answers for your first question will be collected after 2 ½ hours.
2. Use only the pen issued in your back pack.
3. Use only the front side of the sheets of paper provided. Do not use the side marked with a cross.
4. Each question should be answered on separate sheets of paper.
5. For each question, in addition to the **blank writing sheets** where you may write, there is an **answer sheet** where you *must* summarise the results you have obtained. Numerical results should be written with as many digits as are appropriate to the given data. Do not forget to state the units.
6. Write on the blank sheets of paper the results of all your measurements and whatever else you consider is required for the solution of the question and that you wish to be marked. However you should use mainly equations, numbers, symbols, graphs and diagrams. Please use *as little text as possible*.
7. *It is absolutely essential* that you enter in the boxes at the top of each sheet of paper used your **Country** and your student number (**Student No.**). In addition, on the blank sheets of paper used for each question, you should enter the number of the question (**Question No.**), the progressive number of each sheet (**Page No.**) and the total number of blank sheets that you have used and wish to be marked for each question (**Total No. of pages**). It is also helpful to write the question number and the section label of the part you are answering at the beginning of each sheet of writing paper. If you use some blank sheets of paper for notes that you do not wish to be marked, put a large cross through the whole sheet and do not include it in your numbering.
8. When you have finished, arrange all sheets *in proper order* (for each question put answer sheets first, then used sheets in order, followed by the sheets you do not wish to be marked. Put unused sheets and the printed question at the bottom). Place the papers for each question inside the envelope labelled with the appropriate question number, and leave everything on your desk. You are not allowed to take *any* sheets of paper out of the room.

CDROM SPECTROMETER

In this experiment, you are NOT expected to indicate uncertainties in your measurements.

The aim is to produce a graph showing how the conductance* of a light-dependent resistor (LDR) varies with wavelength across the visible spectrum.

*conductance $G = 1/\text{resistance}$ (units: siemens, $1\text{ S} = 1\ \Omega^{-1}$)

There are five parts to this experiment:

- *Using a concave reflection grating (made from a strip of CDROM) to produce a focused first order spectrum of the light from bulb A (12 V 50W tungsten filament).*
- *Measuring and plotting the conductance of the LDR against wavelength as it is scanned through this first order spectrum.*
- *Showing that the filament in bulb A behaves approximately as an ideal black body.*
- *Finding the temperature of the filament in bulb A when it is connected to the 12 V supply.*

- Correcting the graph of conductance against wavelength to take account of the energy distribution within the spectrum of light emitted by bulb A.

Precautions

- Beware of hot surfaces.
- Bulb B should not be connected to any potential difference greater than 2.0 V.
- Do not use the multimeter on its resistance settings in any live circuit.

Procedure

(a) The apparatus shown in Figure 1 has been set up so that light from bulb A falls normally on the curved grating and the LDR has been positioned in the focused **first order** spectrum. Move the LDR through this **first-order** spectrum and observe how its resistance (*measured by multimeter X*) changes with position.

(b) (i) Measure and record the resistance R of the LDR at different positions within this first-order spectrum. Record your data in the blank table provided.

(ii) Plot a graph of the conductance G of the LDR against wavelength λ using the graph paper provided.

Note The angle θ between the direction of light of wavelength λ in the first-order spectrum and that of the white light reflected from the grating (see Figure 1) is given by:

$$\sin \theta = \lambda / d \text{ where } d \text{ is the separation of lines in the grating.}$$

The grating has 620 lines per mm.

The graph plotted in (b)(ii) does not represent the sensitivity of the LDR to different wavelengths correctly as the emission characteristics of bulb A have not been taken into account. These characteristics are investigated in parts (c) and (d) leading to a corrected curve plotted in part (e).

- **Note for part (c) that three multimeters are connected as ammeters. These should NOT be adjusted or moved. Use the fourth multimeter (labelled X) for all voltage measurements.**

(c) If the filament of a 50 W bulb acts as a black-body radiator it can be shown that the potential difference V across it should be related to the current I through it by the expression:

$$V^3 = CI^5 \text{ where } C \text{ is a constant.}$$

Measure corresponding values of V and I for bulb A (in the can). *The ammeter is already connected and should not be adjusted.*

(i) Record your data and any calculated values in the table provided on the answer sheet.

(ii) Plot a suitable graph to show that the filament acts as a black-body radiator on the graph paper provided.

(d) To correct the graph in (b)(ii) we need to know the working temperature of the tungsten filament in bulb A. This can be found from the variation of filament resistance with temperature.

- **You are provided with a graph of tungsten resistivity ($\mu \Omega \text{ cm}$) against temperature (K).**

If the resistance of the filament in bulb A can be found at a known temperature then its temperature when run from the 12 V supply can be found from its resistance at that operating potential difference. Unfortunately its resistance at room temperature is too small to be measured accurately with this apparatus. However, you are provided with a second smaller bulb, C, which has a larger, *measurable* resistance at room temperature. Bulb C can be used as an intermediary by following the procedure described below. You are also provided with a second 12V 50W bulb (B) identical to bulb A. Bulbs B and C are mounted on the board provided and connected as shown in Figure 2.

(i) Measure the resistance of bulb C when it is unlit at room temperature (*use multimeter X*, and take room temperature to be 300 K). Record this resistance R_{C1} on the answer sheet.

- Use the circuit shown in Figure 2 to compare the filaments of bulbs B and C. Use the variable resistor to vary the current through bulb C until you can see that overlapping filaments are at the same temperature. If the small filament is cooler than the larger one it appears as a thin black loop. Measure the resistances of bulbs B and C when this condition has been reached and record their values, R_{C2} and R_B , on the answer sheet. *Remember, the ammeters are already connected.*

(iii) Use the graph of resistivity against temperature (supplied) to work out the temperature of the filaments of B and C when they are matched. Record this temperature, T_{2V} , on the answer sheet.

(iv) Measure the resistance of the filament in bulb A (in the can) when it is connected to the 12 V a.c. supply. *Once again the ammeter is already connected and should not be adjusted.* Record this value, R_{12V} on the answer sheet.

(v) Use the values for the resistance of bulb A at 2 V and 12 V and its temperature at 2 V to work out its temperature when run from the 12 V supply. Record this temperature, T_{12V} in the table on the answer sheet.

- You are provided with graphs that give the relative intensity of radiation from a black-body radiator (Planck curves) at 2000 K, 2250 K, 2500 K, 2750 K, 3000 K and 3250 K.

(e) Use these graphs and the result from (d)(v) to plot a corrected graph of LDR conductance (arbitrary units) versus wavelength using the graph paper provided. Assume that the conductance of the LDR at any wavelength is directly proportional to the intensity of radiation at that wavelength (This assumption is reasonable at the low intensities falling on the LDR in this experiment). Assume also that the grating diffracts light equally to all parts of the first order spectrum.

Figure 1 - Experimental arrangement for (a)

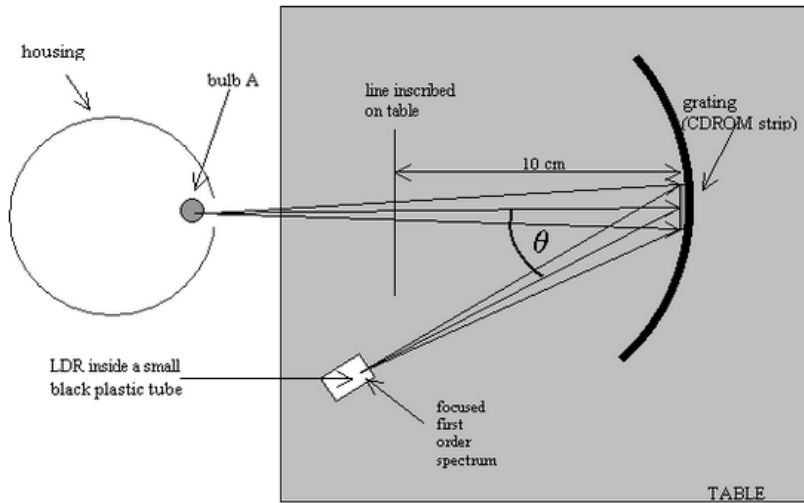

Figure 1: Detail - the grating:

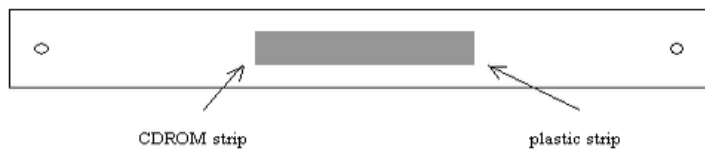

Figure 1: Detail - LDR and Multimeter:

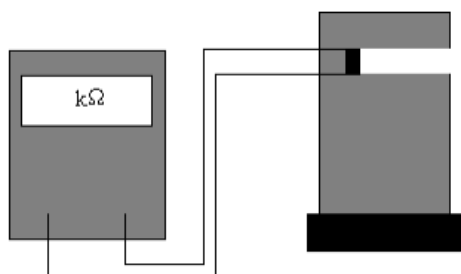
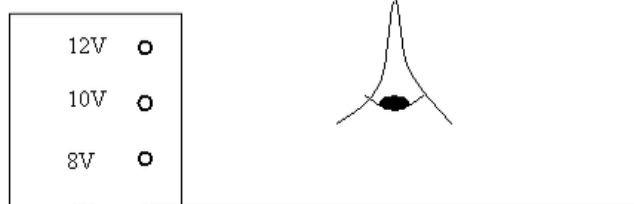
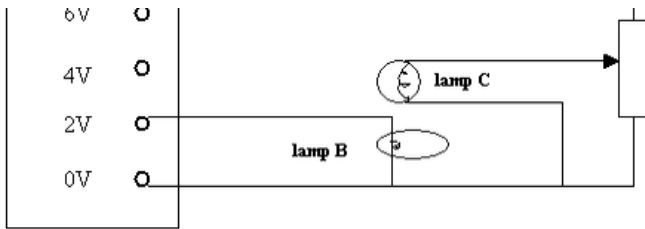

Figure 2

a.c. power supply





Note that this diagram does not show meters

Graph 1

Graph 1: tungsten resistivity

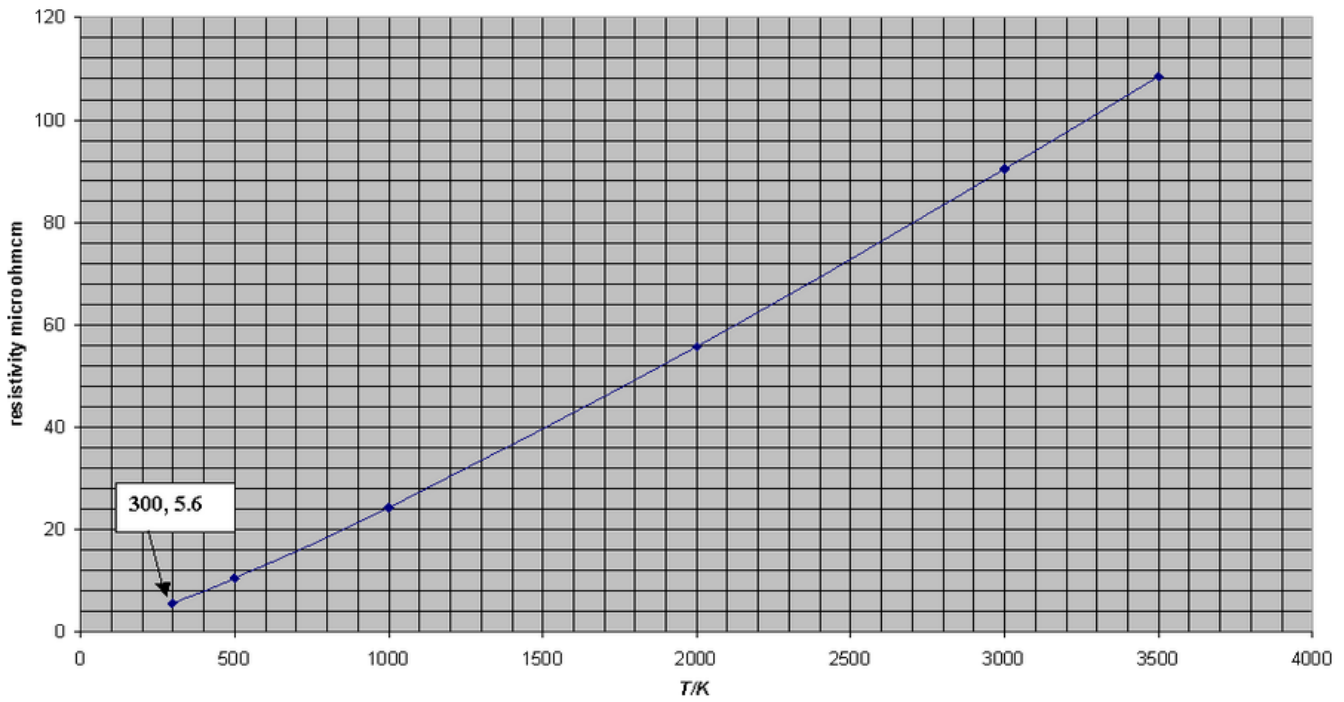

Graph 2a

Graph 2(a): Planck Curves for 2000 K, 2250 K, 2500 K

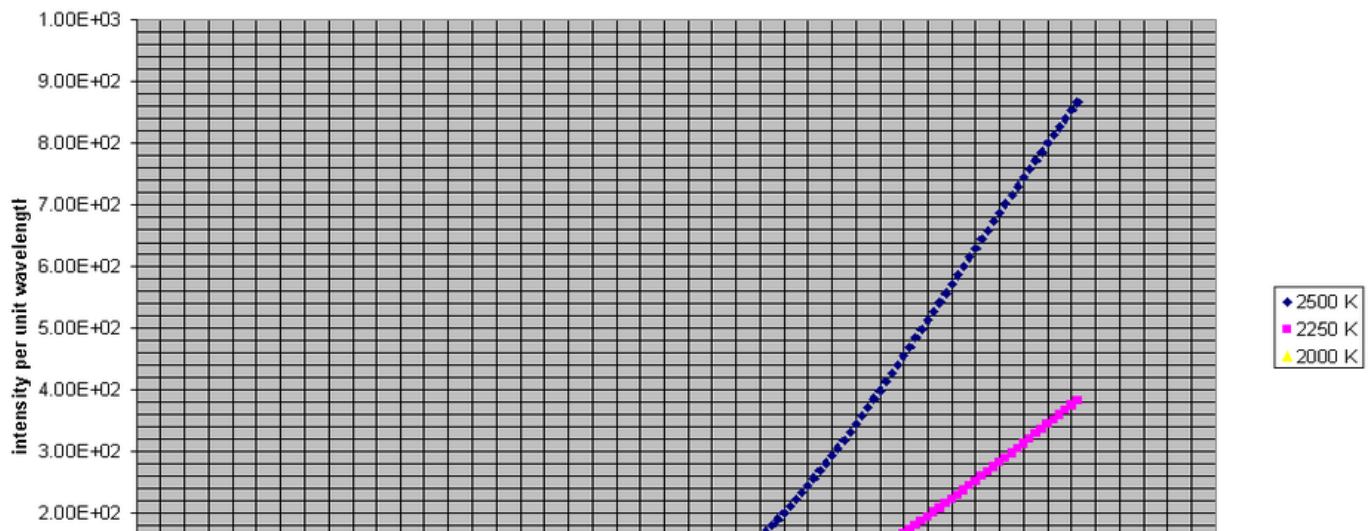

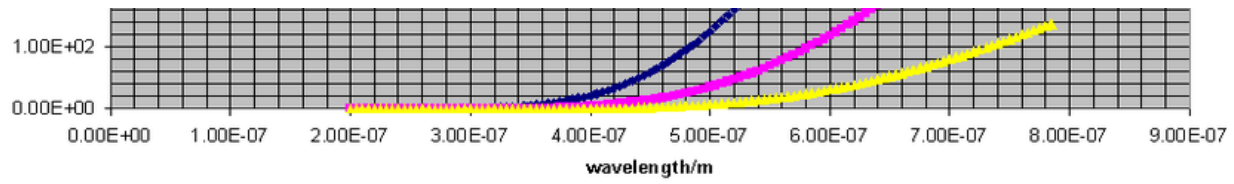

Graph 2b

Graph 2(b): Planck Curves for 2750 K, 3000 K, 3250 K

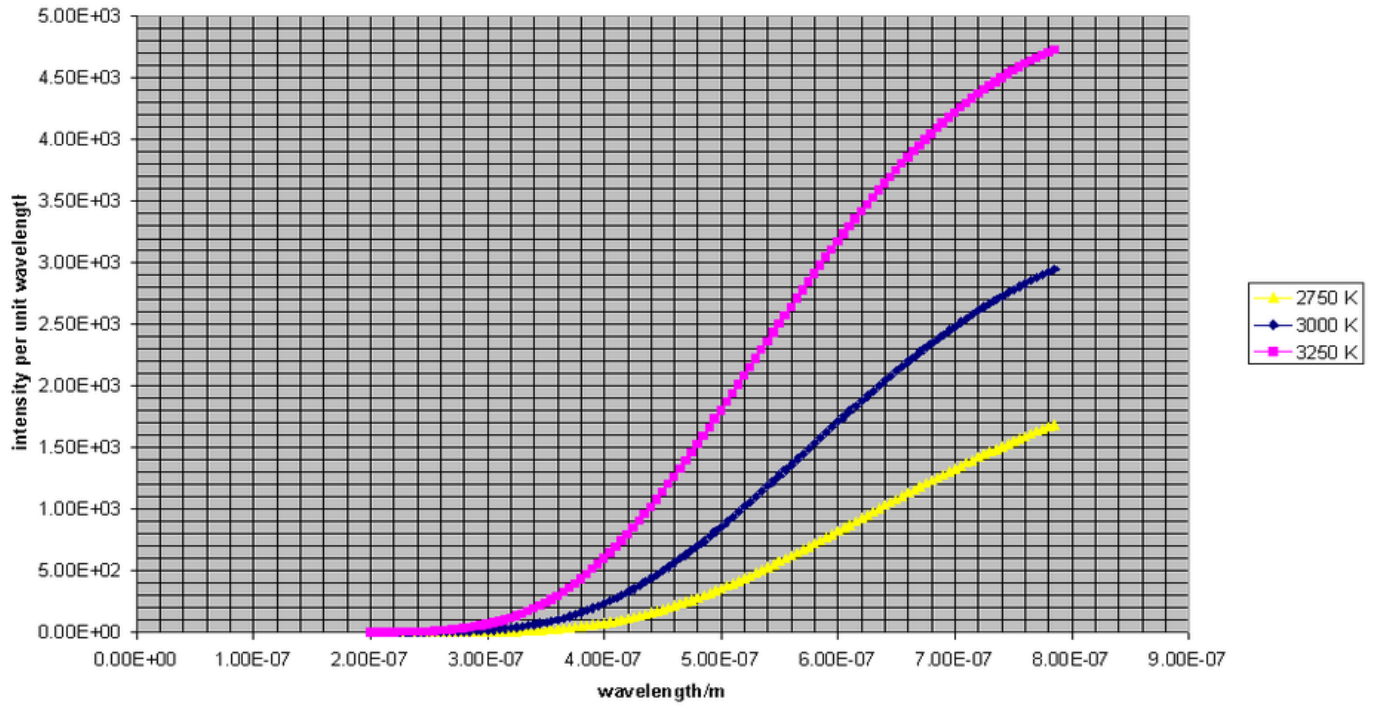

The Magnetic Puck

July 2000

2.5 hours

In this experiment you ARE expected to indicate uncertainties in your measurements, results and graphs

Aim

To investigate the forces on a puck when it slides down the slope.

Warning

Do **not touch** the circular flat faces of the puck or the paper surface of the slope with your hands. Use the glove provided. The faces have different coloured paper stickers for convenience but the frictional characteristics of the paper faces may be assumed to be the same.

Timing

The sensors underneath the track trigger electronic gates in the box and the green LED will light when the puck is between the sensors. The multimeter measures the potential difference across a capacitor, which is connected to a constant-current source (whose current is proportional to the voltage of the battery) whilst the green light is on. The reading of the multimeter is therefore a measure of the time during which the puck is between the sensors. This reading can give a value for the speed of the puck in arbitrary units.

Operating the timer

- i) Press and hold down the black push button on the side of the box. This switches the electronics on.
- ii) If the green light goes on slide the puck (light face up) past the lower sensor. The green light should go off.
- iii) The potential difference across the capacitor can be reduced to zero before the puck is released by pressing the red button for at least 10s.
- iv) The battery potential difference can be measured by connecting the multimeter across the terminals marked with the cell symbol.

Definitions

- (i) A moving body sliding down an inclined plane experiences a tangential retarding force F and a normal reaction N . Define

$$\mu = \frac{F}{N}$$

- (ii) When the retarding force is due to friction alone, μ equals μ_g and is called the dynamic coefficient of friction for the surface. It is independent of speed.
- (iii) When the blue (dark) side is in contact with the plane define

$$\mu_d = \frac{F_d}{N}$$

where the tangential force F_d is partly due to the surface friction and partly due to magnetic effects.

- (iv) The variable μ_{dS} which gives the magnetic effects only is defined by

$$\mu_{dS} = \mu_d - \mu_g$$

Important hints and advice

- (i) You will find it helpful initially to investigate the behaviour of the puck qualitatively.
- (ii) Think about the physics before you do a quantitative investigation. Remember to use graphical presentation where possible.
- (iii) Do not attempt to take too many experimental readings unless you have plenty of time.
- (iv) You are measuring the potential difference across an electrolytic capacitor. This does not behave quite like a simple air capacitor. Slow leakage of charge is normal and the potential difference will not remain completely steady.
- (v) You are given one puck and one 9.0 V battery. Conserve the battery! The constant current filling the capacitor is proportional to the battery potential difference. It is therefore advisable to monitor the battery potential difference. In addition, the sensors may not be reliable if the potential difference of the battery falls below 8.4 V. If this happens, ask for another battery.
- (vi) Your answer pack contains 4 sides of graph paper only. You will not be given further sheets. You may keep the puck at the end of your experiment.
- (vii) If you have trouble operating the multimeters ask an invigilator

(14) *Use the data below to obtain the acceleration due to gravity.*

Data

- Weight of puck = $5.84 \cdot 10^{-2}$ N
- The voltmeter reading indicates the time of travel of the puck. When the potential difference of the battery is 9.0 V then 1 V corresponds to 0.213 s
- Distance between sensors = 0.294 m

Experiment

Using only the apparatus provided investigate how x_{dS} depends on the speed v_q of the puck for track inclinations φ to the horizontal.

State on the answer sheet the algebraic equations/relations used in analysing your results and in plotting your graphs.

Suggest a quantitative model to explain your results. Use the data which you collect to justify your model.

Question 1

A Bungee Jumper

- (a) The jumper comes to rest when

lost gravitational potential energy = stored strain energy

$$mgy = \frac{1}{2} k (y-L)^2$$

$$ky^2 - 2y(kL + mg) + kL^2 = 0$$

This is solved as a quadratic.

$$y = \frac{2(kL + mg) \pm \sqrt{4(kL + mg)^2 - 4k^2 L^2}}{2k}$$
$$= \frac{kL + mg \pm \sqrt{2mgkL + m^2 g^2}}{k}$$

Need positive root; lower position of rest (other root after initial rise).

- (b) The maximum speed is attained when the acceleration is zero and forces balance; i.e. when $mg = kx$

Also kinetic energy = lost potential energy – strain energy within elastic rope

$$\frac{1}{2} m v^2 = mg(L + x) - \frac{1}{2} k x^2$$

$$x = \frac{mg}{k}$$

$$v^2 = 2g\left(L + \frac{mg}{k}\right) - \frac{mg^2}{k}$$

$$v = \sqrt{2gL + \frac{mg^2}{k}}$$

- (c) Time to come to rest = time in free fall + time in SHM of rope to stop stretching

$$\text{Length of free fall} = L = \frac{1}{2} g t_f^2$$

$$\text{Therefore } t_f = \sqrt{\frac{2L}{g}}$$

The jumper enters the SHM with free fall velocity $= gt_f = \sqrt{2gL} = v_f$

$$\text{Period of SHM} = 2\pi\sqrt{\frac{m}{k}} = T$$

We represent a full SHM cycle by

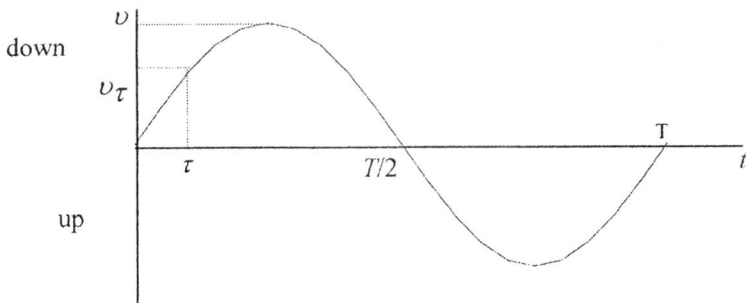

The jumper enters the SHM at time τ given by

$$\tau = \frac{1}{\omega} \sin^{-1} \frac{v_f}{v} = \frac{1}{\omega} \sin^{-1} \frac{\sqrt{2gL}}{v}$$

Jumper comes to rest at one half cycle of the SHM at total time given by

$$= t_f + (T/2 - \tau)$$

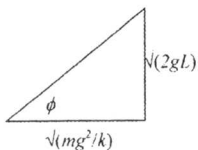

$$\begin{aligned} &= \sqrt{\frac{2L}{g}} + \pi\sqrt{\frac{m}{k}} - \frac{1}{\omega} \sin^{-1} \frac{\sqrt{2gL}}{v} \\ &= \sqrt{\frac{2L}{g}} + \pi\sqrt{\frac{m}{k}} - \frac{1}{\omega} \sin^{-1} \frac{\sqrt{2gL}}{\sqrt{2gL + mg^2/k}} \\ &= \sqrt{\frac{2L}{g}} + \sqrt{\frac{m}{k}} \left\{ \pi - \sin^{-1} \frac{\sqrt{2gL}}{\sqrt{2gL + mg^2/k}} \right\} \end{aligned}$$

This is the same as

$$= \sqrt{\frac{2L}{g}} + \sqrt{\frac{m}{k}} \left\{ \frac{\pi}{2} + \cos^{-1} \frac{\sqrt{2gL}}{\sqrt{2gL + mg^2/k}} \right\}$$

$$= \sqrt{\frac{2L}{g}} + \sqrt{\frac{m}{k}} \tan^{-1} \left\{ \sqrt{\frac{2kL}{mg}} \right\}$$

B Heat Engine Question

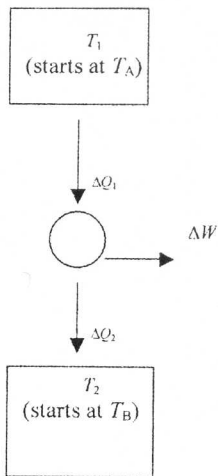

In calculating work obtainable, we assume no loss (friction etc.) in engine working.

$$\begin{aligned}\Delta Q_1 &= \text{energy from body A} \\ &= -ms\Delta T_1 \quad (\Delta T_1 \text{ -ve})\end{aligned}$$

$$\Delta Q_2 = ms\Delta T_2 \quad (\Delta T_2 \text{ +ve})$$

(a) **For maximum amount of mechanical energy assume Carnot engine**

$$\frac{\Delta Q_1}{T_1} = \frac{\Delta Q_2}{T_2} \text{ throughout operation (second law)}$$

But $\Delta Q_1 = -ms\Delta T_1$ and $\Delta Q_2 = ms\Delta T_2$

$$-ms \int_{T_A}^{T_0} \frac{dT_1}{T_1} = ms \int_{T_B}^{T_0} \frac{dT_2}{T_2}$$

$$\ln \frac{T_A}{T_0} = \ln \frac{T_0}{T_B}$$

$$T_0^2 = T_A T_B$$

$$T_0 = \sqrt{T_A T_B}$$

$$Q_1 = -ms \int_{T_A}^{T_0} dT_1 = ms(T_A - T_0)$$

$$Q_2 = ms \int_{T_B}^{T_0} dT_2 = ms(T_0 - T_B)$$

$$W = Q_1 - Q_2$$

$$W = ms(T_A - T_0 - T_0 + T_B) = ms(T_A + T_B - 2T_0) = ms(T_A + T_B - 2\sqrt{T_A T_B})$$

$$\text{or } ms(\sqrt{T_A} - \sqrt{T_B})^2$$

(d) Numerical example:

Mass = volume \times density

$$\begin{aligned} W &= 2.50 \times 1.00 \times 10^3 \times 4.19 \times 10^3 \times (350 + 300 - 2\sqrt{350 \times 300}) \text{ J} \\ &= 20 \times 10^6 \text{ J} \\ &= 20 \text{ MJ} \end{aligned}$$

C Radioactivity and age of the Earth

(a) $N = N_0 e^{-\lambda t}$ $N_0 = \text{original number}$

$$n = N_0(1 - e^{-\lambda t})$$

Therefore $n = N e^{\lambda t}(1 - e^{-\lambda t}) = N(e^{\lambda t} - 1)$

So $n = N(2^{t/\tau} - 1)$ where τ is half-life

or as $\lambda = \frac{\ln 2}{T} = \frac{0.6931}{T}$, $n = N(e^{\frac{0.6931t}{T}} - 1)$

$^{206}_{n} = ^{238}_{N}(2^{t/4.50} - 1)$ or $^{206}_{n} = ^{238}_{N}(e^{0.1540t} - 1)$ where time t is in 10^9 years

(b) $^{207}_{n} = ^{235}_{N}(2^{t/0.710} - 1)$ or $^{207}_{n} = ^{235}_{N}(e^{0.9762t} - 1)$

(c) In mixed uranium (i.e. containing Pb of both natural and radioactive origin)

204 : 206 : 207 have proportions	1.00 : 29.6 : 22.6
In pure lead (no radioactivity)	1.00 : 17.9 : 15.5

Therefore for radioactively produced lead by subtraction

204 : 206 : 207 have proportions	1.00 : 29.6 : 22.6
In pure lead (no radioactivity)	1.00 : 17.9 : 15.5

Therefore for radioactivity produced lead by subtraction

206 : 207	11.7 : 7.1
-----------	------------

Dividing equations from (a) and (b) gives

$$\frac{^{206}_n}{^{207}_n} = \frac{^{238}_N}{^{235}_N} \left\{ \frac{2^{t/4.50} - 1}{2^{t/0.710} - 1} \right\} \text{ or } \frac{^{206}_n}{^{207}_n} = \frac{^{238}_N}{^{235}_N} \left\{ \frac{e^{0.1540t} - 1}{e^{0.9762t} - 1} \right\}$$

$$\frac{11.7}{7.1} = 137 \left\{ \frac{2^{T/4.50} - 1}{2^{T/0.710} - 1} \right\} \text{ or } \frac{11.7}{7.1} = 137 \left\{ \frac{e^{0.1540T} - 1}{e^{0.9762T} - 1} \right\}$$

$$0.0120 \{2^{T/0.710} - 1\} = \{2^{T/4.50} - 1\}$$

$$\text{or } 0.0120 \{e^{0.9762T} - 1\} = \{e^{0.1540T} - 1\}$$

(d) Assume $T \gg 4.50 \times 10^9$ and ignore 1 in both brackets:

$$0.0120 \{2^{T/0.710}\} = \{2^{T/4.50}\} \text{ or } 0.0120 \{e^{0.9762T}\} = \{e^{0.15407}\}$$

$$0.0120 = \{2^{T/4.50 - T/0.710}\} = 2^{T(0.222-1.4084)} = 2^{-1.18627}$$

$$T = -\frac{\log 0.0120}{\log 2 \times 1.1862} = 5.38$$

$$T = 5.38 \times 10^9 \text{ years}$$

$$\text{or } 0.0120 = e^{-0.8222T} \quad T = \frac{\ln 0.0120}{-0.8222} = \frac{-4.4228}{-0.8222} = 5.38$$

$$T = 5.38 \times 10^9 \text{ years}$$

(e) T is not $\gg 4.50 \times 10^9$ years but is $> 0.71 \times 10^9$ years

We can insert the approximate value for T (call it $T^* = 5.38 \times 10^9$ years) in the $2^{T/4.50}$ term and obtain a better value by iteration in the rapidly changing $2^{T/0.710}$ term). We now leave in the -1's, although the -1 on the right-hand side has little effect and may be omitted).

$$\text{Either} \quad 0.0120((2^{T/0.710} - 1) = 2^{T^*/4.50} - 1$$

$$2^{T/0.710} - 1 = \frac{2^{1.1956} - 1}{0.0120} = \frac{2.2904 - 1}{0.0120} = 107.5$$

$$T = 0.710 \frac{\log 108.5}{\log 2} = 4.80(0)$$

Put $T^* = 4.80(0) \times 10^9$ years

$$2^{T/0.710} = \frac{2^{1.0668} - 1}{0.0120} = \frac{2.0948 - 1}{0.0120} = 91.2$$

$$T = 0.710 \frac{\log 91.2}{\log 2} = 4.62(3)$$

Further iteration gives 4.52

So more accurate answer for T to be in range 4.6×10^9 years to 4.5×10^9 years (either acceptable).

D Spherical charge

(a) Charge density = $\rho = \frac{Q}{\frac{4}{3}\pi R^3}$ within sphere

$x \leq R$ Field at distance x :

$$E = \frac{\frac{4}{3}\pi x^3 \rho}{4\pi\epsilon_0 x^2} = \frac{Qx}{4\pi\epsilon_0 R^3}$$

$x > R$ Field at distance x from the centre: $E = \frac{Q}{4\pi\epsilon_0 x^2}$

(b) Method 1

Energy density is $\frac{1}{2}\epsilon_0 E^2$.

$x \leq R$

Energy in a thin shell of thickness δx at radius x is given by

$$= \frac{1}{2}\epsilon_0 E^2 4\pi x^2 \delta x = \frac{1}{2}4\pi\epsilon_0 \frac{Q^2 x^2}{(4\pi\epsilon_0)^2 R^6} x^2 \delta x$$

$$\text{Energy within the spherical volume} = \frac{1}{2} \frac{Q^2}{(4\pi\epsilon_0)R^6} \int_{x=0}^{x=R} x^4 dx = \frac{1}{40} \frac{Q^2}{\pi\epsilon_0} \frac{1}{R}$$

$x > R$

$$\text{Energy within spherical shell} = \frac{1}{2}\epsilon_0 E^2 4\pi x^2 \delta x = \frac{1}{2}4\pi\epsilon_0 \frac{Q^2}{(4\pi\epsilon_0)^2 x^4} x^2 \delta x$$

Energy within the spherical volume for $x > R$

$$= \frac{1}{2} \frac{Q^2}{(4\pi\epsilon_0)} \int_{x=R}^{x=\infty} \frac{1}{x^2} dx = \frac{1}{8} \frac{Q^2}{\pi\epsilon_0} \frac{1}{R}$$

$$\text{Total energy associated with the charge distribution} = \frac{1}{40} \frac{Q^2}{\pi\epsilon_0} \frac{1}{R}$$

$$+ \frac{1}{8} \frac{Q^2}{\pi\epsilon_0} \frac{1}{R}$$

$$= \frac{3}{20} \frac{Q^2}{\pi\epsilon_0} \frac{1}{R}$$

Method 2

A shell with charge $4\pi x^2 \delta x \rho$ moves from ∞ to the surface of a sphere radius x where the electric potential is

$$\frac{\frac{4}{3}\pi x^3 \rho}{4\pi \epsilon_0 x} = \frac{x^2 \rho}{3\epsilon_0}$$

and will therefore gain electrical potential energy $\left(\frac{x^2 \rho}{3\epsilon_0}\right)(4\pi x^2 \rho) \delta x$

$$\text{Total energy of complete sphere} = \int_{x=0}^{x=R} \frac{4\pi \rho^2 x^4}{3\epsilon_0} dx = \frac{4}{15} \frac{\pi \rho^2 R^5}{\epsilon_0}$$

$$\text{Putting } Q = \text{charge on sphere} = \frac{4}{3}\pi R^3 \rho, \quad \rho = \frac{3Q}{4\pi R^3}$$

$$\text{So that total energy is} = \frac{4}{15} \pi \left(\frac{9Q^2}{16\pi^2 R^6}\right) \frac{R^5}{\epsilon} = \frac{3}{20} \frac{Q^2}{\pi \epsilon_0 R}$$

(c) Binding energy $E_{\text{binding}} = E_{\text{electric}} - E_{\text{nuclear}}$

Binding energy is a negative energy

Therefore $-8.768 = E_{\text{electric}} - 10.980 \text{ MeV per nucleon}$

$E_{\text{electric}} = 2.212 \text{ MeV per nucleon}$

Radius of cobalt nucleus is given by $R = \frac{3}{20} \frac{Q^2}{\pi \epsilon_0 E_{\text{electric}}^{\text{total}}}$

$$= \frac{3 \times 27^2 \times (1.60 \times 10^{-19})^2}{20 \times \pi \times 8.85 \times 10^{-12} \times 2.212 \times 10^6 \times 57 \times 1.60 \times 10^{-19}} \text{ m}$$

$$= 5.0 \times 10^{-15} \text{ m}$$

$$T = \frac{4\rho d \ln 2}{B^2} = \frac{4 \times 1.70 \times 10^{-8} \times 8.90 \times 10^3 \times 0.6931}{(44.5 \times 10^{-6} \times 0.4384)^2} \text{ s}$$

$$= 1.10(2) \times 10^6 \text{ s } (=306 \text{ hr } = 12 \text{ days } 18 \text{ hr})$$

E. E.M. Induction

Method 1 Equating energy

Horizontal component of magnetic field B inducing emf in ring:

$$B = 44.5 \times 10^{-6} \cos 64^\circ$$

Magnetic flux through ring at angle $\theta = B\pi a^2 \sin \theta$

where a = radius of ring

$$\begin{aligned} \text{Instantaneous emf} &= \frac{d\phi}{dt} = B\pi a^2 \frac{d \sin \omega t}{dt} \quad \text{where } \omega = \text{angular velocity} \\ &= B\pi a^2 \omega \cos \omega t = B\pi a^2 \omega \cos \theta \end{aligned}$$

$$\text{R.m.s. emf over 1 revolution} = \frac{B\pi a^2 \omega}{\sqrt{2}}$$

$$\text{Average resistive heating of ring} = \frac{B^2 \delta^2 a^4 \omega^2}{2R}$$

$$\text{Moment of inertia} = \frac{1}{2} m a^2$$

$$\text{Rotational energy} = \frac{1}{4} m a^2 \omega^2 \quad \text{where } m = \text{mass of ring}$$

$$\text{Power producing change in } \omega = \frac{d}{dt} \left\{ \frac{1}{4} m a^2 \omega^2 \right\} =$$

$$\frac{1}{4} m a^2 2\omega \frac{d\omega}{dt}$$

$$\text{Equating:} \quad \frac{1}{2} m a^2 \omega \frac{d\omega}{dt} = - \frac{B^2 \delta^2 a^4 \omega^2}{2R}$$

$$\frac{d\omega}{\omega} = - \frac{B^2 \pi^2 a^2}{mR} dt$$

If T is time for angular velocity to halve,

$$\int_{\omega}^{\omega/2} \frac{d\omega}{\omega} = - \int_0^T \frac{B^2 \pi^2 a^2}{mR} dt$$

$$\ln 2 = \frac{B^2 \delta^2 a^2}{mR} T$$

But $R = \frac{2\delta a\rho}{A}$ where A is cross-sectional area of copper ring

$m = 2\pi a d A$ (d = density)

$$\ln 2 = \frac{B^2 \delta^2 a^2 T}{\frac{2\delta a\rho}{A} 2\delta a d A} = \frac{B^2 T}{4\rho d}$$

$$\begin{aligned} T &= \frac{4\rho d \ln 2}{B^2} = \frac{4 \times 1.70 \times 10^{-8} \times 8.90 \times 10^3 \times 0.6931}{(44.5 \times 10^{-6} \times 0.4384)^2} \text{ s} \\ &= 1.10(2) \times 10^6 \text{ s} \quad (= 306 \text{ hr} = 12 \text{ days } 18 \text{ hr}) \end{aligned}$$

Method 2 Back Torque

Horizontal component of magnetic field = $B = 44.5 \times 10^{-6} \cos 64^\circ$

Cross-section of area of ring is A

Radius of ring = a

Density of ring = d

Resistivity = ρ

ω = angular velocity (ω positive when clockwise)

$$\text{Resistance } R = \rho \frac{2\pi a}{A}$$

$$\text{Mass of ring } m = 2\pi a A d$$

$$\text{Moment of inertia } = M = \frac{1}{2} m a^2$$

Magnetic flux through ring at angle $\theta = B\pi a^2 \sin \theta$

$$\text{Instantaneous emf} = \frac{d\phi}{dt} = B\pi a^2 \frac{d \sin \omega t}{dt} = B\pi a^2 \omega \cos \omega t = B\pi a^2 \omega \cos \theta$$

$$\text{Induced current} = I = B\pi a^2 \omega \cos \theta / R$$

$$\text{Torque opposing motion} = (B\pi a^2 \cos \theta) I = \frac{1}{R} (B\pi a^2)^2 \omega \cos^2 \theta$$

$$\text{Work done in small } \delta\theta = \frac{1}{R} (B\pi a^2)^2 \omega \frac{1}{2} (\cos 2\theta + 1) \delta\theta$$

Average torque = (work done in 2π revolution) / 2π

$$= \frac{1}{2\pi R} (B\pi a^2)^2 \omega \frac{1}{2} 2\pi = \frac{1}{2R} (B\pi a^2)^2 \omega$$

$$\text{This equals } M \frac{d\omega}{dt} \text{ so that } M \frac{d\omega}{dt} = - \frac{B(\pi a^2) B(\pi a^2) \frac{1}{2} \omega}{(\rho / A)(2\pi a)}$$

$$\frac{1}{2} (2\pi a A d) a^2 \frac{d\omega}{dt} = - \frac{B^2 (\pi a^2)^2 A}{4\rho \pi a} \omega$$

$$\frac{d\omega}{dt} = - \frac{B^2}{4\rho d} \omega$$

$$\int_{\omega}^{\omega/2} \frac{d\omega}{\omega} = \int_0^T \frac{B^2}{4\rho d} dt$$

$$\ln 2 = \frac{B^2 T}{4\rho d}$$

$$T = \frac{4\rho d \ln 2}{B^2} = \frac{4 \times 1.70 \times 10^{-8} \times 8.90 \times 10^3 \times 0.6931}{(44.5 \times 10^{-6} \times 0.4384)^2} \text{ s}$$

$$= 1.10(2) \times 10^6 \text{ s} = 306 \text{ hr} = 12 \text{ days } 18 \text{ hr}$$

Question Two ~ Solution

- (a) Focusing occurs for one "cyclotron" orbit of the electron.

Angular velocity $\omega = e B / m$; so time for one orbit $T = 2 \pi m / e B$

Speed of electron $u = (2 e V / m)^{1/2}$

Distance travelled $D = T u \cos \beta \approx T u = (2^{3/2} \pi / B) (V m / e)^{1/2}$

Thus charge to mass ratio $= e / m = 8 V \times (\pi / B D)^2$

- (b) Consider condition (ii) - Force due to electric field acts upwards

In region A force due magnetic field acts upwards as well, electron hits upper plate and does not reach the film.

In region B, force due magnetic field acts downwards, and *if* force is equal and opposite to the electrostatic force, there will be no unbalanced force, and electron will emerge from plates to expose film.

Piece was taken from region B.

- (c) We require forces to balance. Electric force given by eV / t , magnitude of magnetic force given by $e u B \sin \phi$, with u the speed of the electron.

For these to balance we require $u = V / t B |\sin \phi|$

Maximum u corresponds to minimum ϕ - at 23°

Therefore $u = 2.687 \times 10^8 \text{ m/s} = 0.896 c$.

Relativistic $\gamma = (1 - v^2/c^2)^{-1/2} = 2.255$,

so kinetic energy of electron $= (\gamma - 1) m c^2 = 641 \text{ keV}$.

- (d) After emerging from region between plates, electrons experience force due to magnetic field only. We approximate this by a vertical force, because angle of electron to horizontal remains small.

Acceleration caused by this force $a = B e u \sin \phi / \gamma m$

Initial horizontal speed is u , therefore time taken to reach the film after emerging from the region between the plates $t = s / u$.

Change in vertical displacement during this time $= y / 2 = \frac{1}{2} a (s / u)^2$

$$y = B e s^2 \sin \phi / \gamma m u$$

From part (f), for electron to have emerged from plate, we also know $u = V / t B \sin \phi$.

Therefore we eliminate u to obtain:

$$y^2 = (e B s \sin \phi / m)^2 \{ (B s t \sin \phi / V)^2 - (s / c)^2 \}$$

and we plot VERTICAL $(y / B s \sin \phi)^2$

HORIZONTAL $(B s t \sin \phi / V)^2$

Therefore we have a gradient $(e / m)^2$

and a vertical-axis intercept $-(e s / m c)^2$

The intercept is read as $-537.7 \text{ (C s / kg)}^2$, giving $e/m = 1.70 \times 10^{11} \text{ C / kg}$

The gradient is read as $2.826 \times 10^{22} \text{ (C/kg)}^2$, giving $e/m = 1.68 \times 10^{11} \text{ C / kg}$.

A a) $\Delta x_t = ae^{-\mu t} \cos(\omega t + \phi)$, $0.8 = e^{-50\mu} \Rightarrow \mu = 4.5 \times 10^{-3} \text{ s}^{-1}$.

b) $v = (E/\rho)^{1/2} = (7.1 \times 10^{10}/2700)^{1/2} = 5100 \text{ m}\cdot\text{s}^{-1}$.
 At fundamental $\lambda_{rod} = 4l = 4 \text{ m}$.
 $f = 5100 / 4 = 1.3 \times 10^3 \text{ Hz}$.
 $\omega = 2\pi f = 8.1 \times 10^3 \text{ rad}\cdot\text{s}^{-1}$.

c) $v = f\lambda_{rod}$, $\delta\lambda_{rod} / \lambda_{rod} = (-)\delta f / f \Rightarrow \delta l / l$.
 $\delta l = l \cdot (\delta f / f)$.

[0.6]

$$\delta l = 1 \times (5.0 \times 10^{-3} / 1.3 \times 10^3) = 3.8 \times 10^{-6} \text{ m}.$$

d) Change in gravitational force on rod at a distance x from the free end $= m\Delta g$ and $m = \rho x A$,
 where A is the cross-sectional area of the rod.

Change in stress $= m\Delta g / A = \rho x \Delta g$.

Change in strain $= \delta(dx) / dx = \rho x \Delta g / E$;

that is, $dx \rightarrow (1 + \rho x \Delta g / E) dx \Rightarrow \Delta l = (\rho \Delta g / 2E) l^2$.

e) At fundamental $\lambda_{rod} = 4l \Rightarrow \Delta l = \Delta \lambda_{rod} / 4$,
 for $\Delta \lambda_{rod} = 656 \text{ nm} / 10^4 \Rightarrow \Delta l = 656 \text{ nm} / (4 \times 10^4)$.
 $\Delta l = 656 \text{ nm} / (4 \times 10^4) = (\rho \Delta g / 2E) l^2$

[0.1]

$$\Delta l = (2700 \times 10^{-19} / 14 \times 10^{10}) l^2 \Rightarrow l = 9.2 \times 10^7 \text{ m}.$$

B a) $mc^2 = hf \Rightarrow m = hf / c^2$,

[0.3]

$$hf' = hf - GMm/R,$$

$$\Rightarrow hf' = hf(1 - GM/Rc^2), \therefore f' = f(1 - GM/Rc^2).$$

b) $n_r = c / c(1 - GM/rc^2)^2$,

$$n_r = 1 + 2GM/rc^2, \text{ for small } GM/rc^2; \text{ i.e. } \alpha = 2.$$

c)

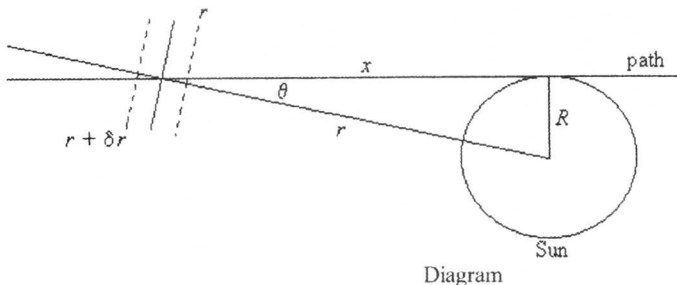

By Snell's law: $n(r + \delta r) \sin \theta = n(r) \sin (\theta - \delta \xi)$,

$$(n(r) + (dn/dr) \delta r) \sin \theta = n(r) \sin \theta - n(r) \cos \theta \delta \xi.$$

$$(dn/dr) \delta r \sin \theta = -n(r) \cos \theta \delta \xi.$$

Now $n(r) = 1 + 2GM/rc^2$, so $(dn/dr) = -2GM/c^2r^2$,

$$\text{and } (2GM/c^2r^2) \sin \theta \delta r = n(r) \cos \theta \delta \xi.$$

Hence $\delta \xi = (2GM/c^2r^2) \tan \theta (\delta r/n) \approx (2GM \tan \theta /c^2r^2)\delta r$.

Now $r^2 = x^2 + R^2$, so $r dr = x dx$.

$$\int d\xi = \frac{2GM}{c^2} \int \frac{\tan \theta dr}{r^2} = \frac{2GM}{c^2} \int \frac{\tan \theta dx}{r^3} = \frac{2GMR}{c^2} \int_{-\infty}^{\infty} \frac{dx}{(x^2 + R^2)^{3/2}}$$

$$\xi = \frac{4GM}{Rc^2} \text{ radians} = 8.4 \times 10^{-6} \text{ radians.}$$

Theoretical Competition

Monday, July 2nd, 2001

Please read this first:

1. The time available is 5 hours for the theoretical competition.
2. Use only the pen provided.
3. Use only the front side of the paper.
4. Begin each part of the problem on a separate sheet.
5. For each question, in addition to the **blank sheets** where you may write, there is an **answer form** where you *must* summarize the results you have obtained. Numerical results should be written with as many digits as are appropriate to the given data.
6. Write on the blank sheets of paper whatever you consider is required for the solution of the question. Please use *as little text as possible*; express yourself primarily in equations, numbers, figures, and plots.
7. Fill in the boxes at the top of each sheet of paper used by writing your **Country No** and **Country Code**, your student number (**Student No**), the number of the question (**Question No**), the progressive number of each sheet (**Page No**), and the total number of blank sheets used for each question (**Total No of pages**). Write the question number and the section letter of the part you are answering at the top of each sheet. If you use some blank sheets of paper for notes that you do not wish to be marked, put a large X across the entire sheet and do not include it in your numbering.
8. At the end of the exam, arrange all sheets for each problem *in the following order*;
 - answer form
 - used sheets in order
 - the sheets you do not wish to be marked
 - unused sheets and the printed question

Place the papers inside the envelope and leave everything on your desk. You are not allowed to take *any* sheets of paper out of the room.

Question 1

1a) KLYSTRON

Klystrons are devices used for amplifying very high-frequency signals. A klystron basically consists of two identical pairs of parallel plates (cavities) separated by a distance b , as shown in the figure.

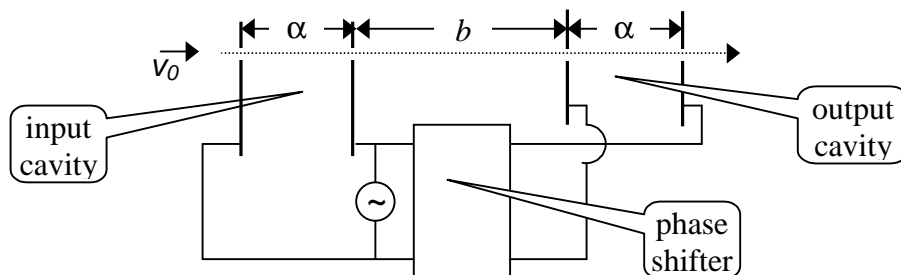

An electron beam with an initial speed v_0 traverses the entire system, passing through small holes in the plates. The high-frequency voltage to be amplified is applied to both pairs of plates with a certain phase difference (where period T corresponds to 2π phase) between them, producing horizontal, alternating electric fields in the cavities. The electrons entering the input cavity when the electric field is to the right are retarded and vice versa, so that the emerging electrons form bunches at a certain distance. If the output cavity is placed at the bunching point, the electric field in this cavity will absorb power from the beam provided that its phase is appropriately chosen. Let the voltage signal be a square wave with period $T=1.0 \times 10^{-9}$ s, changing between $V=\pm 0.5$ volts. The initial velocity of the electrons is $v_0=2.0 \times 10^6$ m/s and the charge to mass ratio is $e/m=1.76 \times 10^{11}$ C/kg. The distance α is so small that the transit time in the cavities can be neglected. Keeping 4 significant figures, calculate;

- the distance b , where the electrons bunch. Copy your result onto the **answer form**. [1.5 pts]
- the necessary phase difference to be provided by the phase shifter. Copy your result onto the **answer form**. [1.0 pts]

1b) INTERMOLECULAR DISTANCE

Let d_L and d_V represent the average distances between molecules of water in the liquid phase and in the vapor phase, respectively. Assume that both phases are at 100°C and atmospheric pressure, and the vapor behaves like an ideal gas. Using the following data, calculate the ratio d_V/d_L and copy your result onto the **answer form**. [2.5 pts]

Density of water in liquid phase: $\rho_L=1.0 \times 10^3$ kg/m³,

Molar mass of water: $M=1.8 \times 10^{-2}$ kg/mol

Atmospheric pressure: $P_a=1.0 \times 10^5$ N/m²

Gas constant: $R=8.3$ J/mol K

Avogadro's number: $N_A=6.0 \times 10^{23}$ /mol

1c) SIMPLE SAWTOOTH SIGNAL GENERATOR

A sawtooth voltage waveform V_0 can be obtained across the capacitor C in Fig. 1. R is a variable resistor, V_i is an ideal battery, and SG is a spark gap consisting of two electrodes with an adjustable distance between them. When the voltage across the electrodes exceeds the firing voltage V_f , the air between the electrodes breaks down, hence the gap becomes a short circuit and remains so until the voltage across the gap becomes very small.

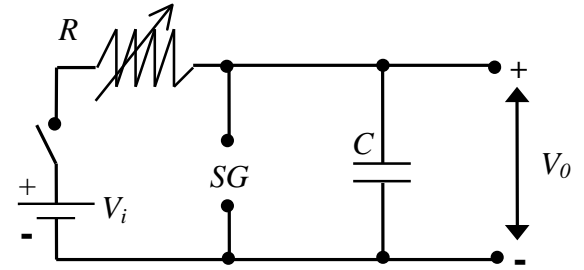

Figure 1

- Draw the voltage waveform V_0 versus time t , after the switch is closed. [0.5 pts]
- What condition must be satisfied in order to have an almost linearly varying sawtooth voltage waveform V_0 ? Copy your result onto the **answer form**. [0.2 pts]
- Provided that this condition is satisfied, derive a simplified expression for the period T of the waveform. Copy your result onto the **answer form**. [0.4 pts]
- What should you vary(R and/or SG) to change the period only? Copy your result onto the **answer form**. [0.2 pts]
- What should you vary (R and/or SG) to change the amplitude only? Copy your result onto the **answer form**. [0.2 pts]
- You are given an additional, adjustable DC voltage supply. Design and draw a new circuit indicating the terminals where you would obtain the voltage waveform V'_0 described in Fig. 2. [1.0 pts]

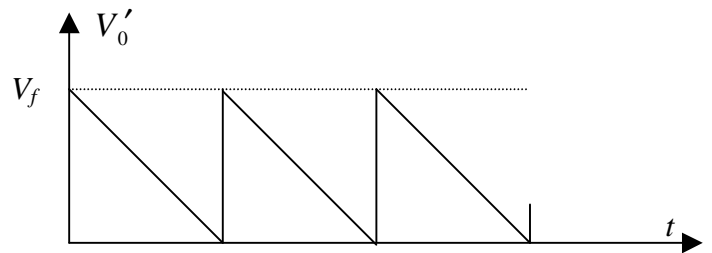
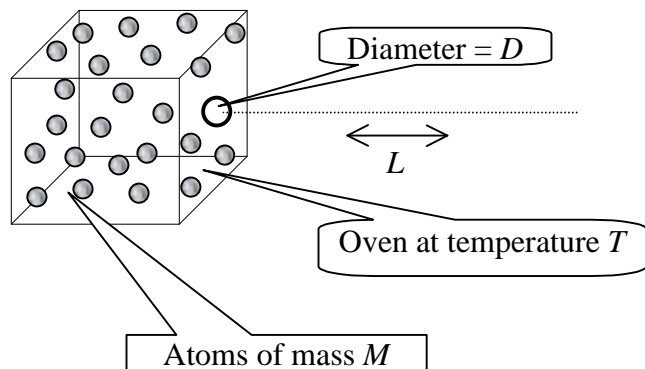

Figure 2

1d) ATOMIC BEAM

An atomic beam is prepared by heating a collection of atoms to a temperature T and allowing them to emerge horizontally through a small hole (of atomic dimensions) of diameter D in one side of the oven. Estimate the diameter of the beam after it has traveled a horizontal length L along its path. The mass of an atom is M . Copy your result onto the **answer form**. [2.5 pts]



Question 2

BINARY STAR SYSTEM

a) It is well known that most stars form binary systems. One type of binary system consists of an ordinary star with mass m_0 and radius R , and a more massive, compact neutron star with mass M , rotating around each other. In all the following ignore the motion of the earth. Observations of such a binary system reveal the following information:

- The maximum angular displacement of the ordinary star is $\Delta\theta$, whereas that of the neutron star is $\Delta\phi$ (see Fig. 1).
- The time it takes for these maximum displacements is τ .
- The radiation characteristics of the ordinary star indicate that its surface temperature is T and the radiated energy incident on a unit area on earth's surface per unit time is P .
- The calcium line in this radiation differs from its normal wavelength λ_0 by an amount $\Delta\lambda$, due only to the gravitational field of the ordinary star. (For this calculation the photon can be considered to have an effective mass of $h/c\lambda$.)

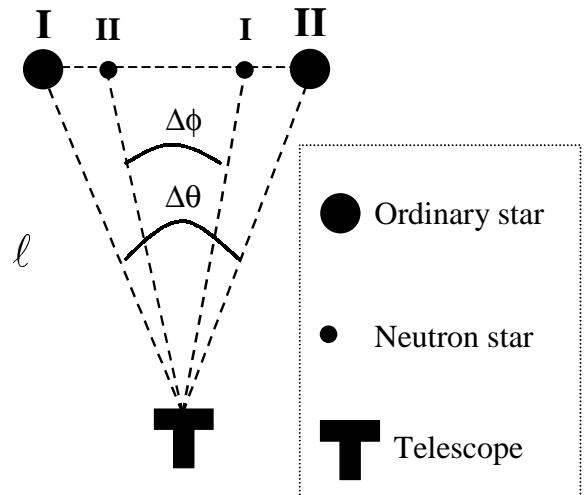

Fig. 1

Find an expression for the distance ℓ from earth to this system, only in terms of the observed quantities and universal constants. Copy your result onto the **answer form**. [7 pts]

b) Assume that $M \gg m_0$, so that the ordinary star is basically rotating around the neutron star in a circular orbit of radius r_0 . Assume that the ordinary star starts emitting gas toward the neutron star with a speed v_0 , relative to the ordinary star (see Fig. 2). Assuming that the neutron star is the dominant gravitational force in this problem and neglecting the orbital changes of the ordinary star find the distance of closest approach r_f shown in Fig. 2. Copy your result onto the **answer form**. [3pts]

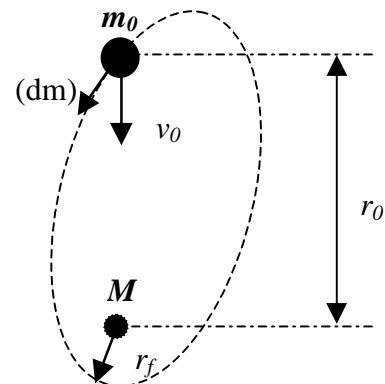
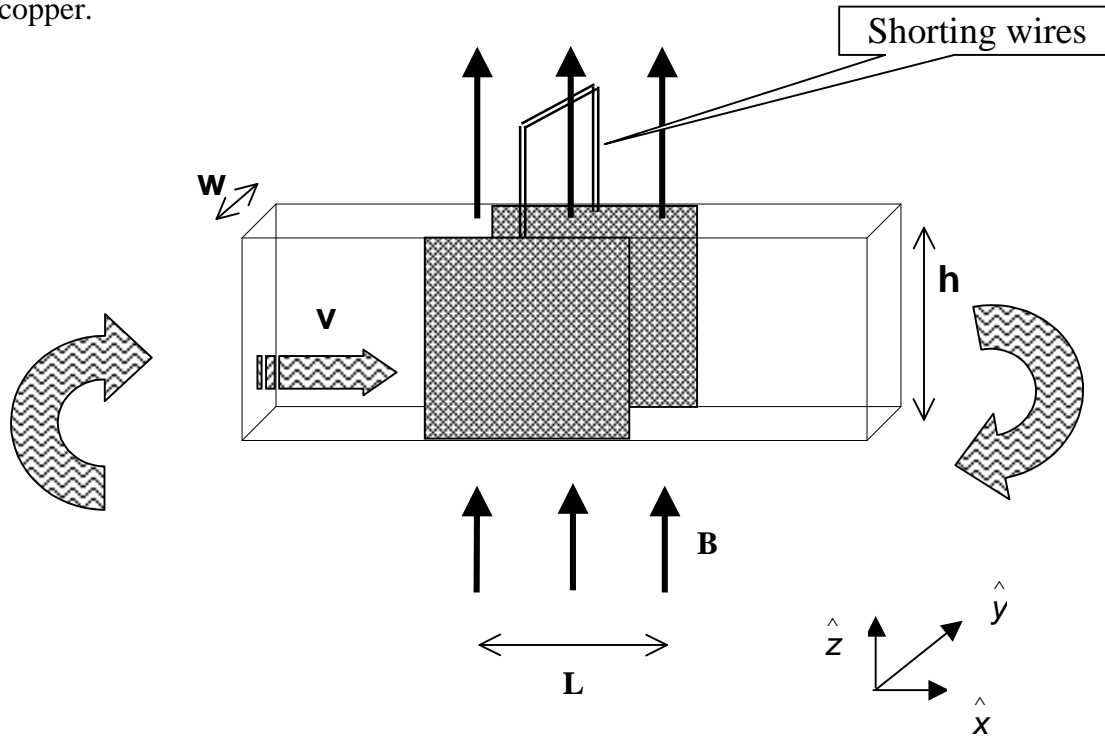

Fig. 2

Question 3
MAGNETOHYDRODYNAMIC (MHD) GENERATOR

A horizontal rectangular plastic pipe of width w and height h , which closes upon itself, is filled with mercury of resistivity ρ . An overpressure P is produced by a turbine which drives this fluid with a constant speed v_0 . The two opposite vertical walls of a section of the pipe with length L are made of copper.



The motion of a real fluid is very complex. To simplify the situation we assume the following:

- Although the fluid is viscous, its speed is uniform over the entire cross section.
- The speed of the fluid is always proportional to the net external force acting upon it.
- The fluid is incompressible.

These walls are electrically shorted externally and a uniform, magnetic field \mathbf{B} is applied vertically upward only in this section. The set up is illustrated in the figure above, with the unit vectors \hat{x} , \hat{y} , \hat{z} to be used in the solution.

- Find the force acting on the fluid due to the magnetic field (in terms of L , B , h , w , ρ and the new velocity v) [2.0 pts]
- Derive an expression for the new speed v of the fluid (in terms of v_0 , P , L , B and ρ) after the magnetic field is applied. [3.0 pts]
- Derive an expression for the additional power that must be supplied by the turbine to increase the speed to its original value v_0 . Copy your result onto the **answer form**. [2.0 pts]
- Now the magnetic field is turned off and mercury is replaced by water flowing with speed v_0 . An electromagnetic wave with a single frequency is sent along the section with length L in the direction of the flow. The refractive index of water is n , and $v_0 \ll c$. Derive an expression for the contribution of the fluid's motion to the phase difference between the waves entering and leaving section L . Copy your result onto the **answer form**. [3.0 pts]

Country no	Country code	Student No.	Question No.	Page No.	Total No. of pages

ANSWER FORM

1A

a)

$b =$

b)

Phase difference=

1B

$\frac{d_V}{d_L} =$

Country no	Country code	Student No.	Question No.	Page No.	Total No. of pages

1C

b)

c)

$T =$

d)

e)

1D

New diameter of the beam =

Country no	Country code	Student No.	Question No.	Page No.	Total No. of pages

ANSWER FORM

2a)

$l =$

2b)

$r_f =$

Country no	Country code	Student No.	Question No.	Page No.	Total No. of pages

ANSWER FORM

3a)

3b)

v =

3c)

Power =

3d)

Phase difference =

Experimental Competition

Saturday, June 30th, 2001

Please read this first:

1. The time available is 5 hours for the experimental competition.
2. Use only the pen provided.
3. Use only the front side of the paper.
4. Begin each part of the problem on a separate sheet.
5. For each question, in addition to the *blank sheets* where you may write, there is an *answer form* where you *must* summarize the results you have obtained. Numerical results should be written with as many digits as are appropriate to the given data.
6. Write on the blank sheets of paper the results of all your measurements and whatever else you consider is required for the solution of the question. Please use *as little text as possible*; express yourself primarily in equations, numbers, figures and plots.
7. Fill in the boxes at the top of each sheet of paper used by writing your *Country no* and *Country code*, your student number (*Student No.*), the number of the question (*Question No.*), the progressive number of each sheet (*Page No.*) and the total number of blank sheets used for each question (*Total No. of pages*). Write the question number and the section label of the part you are answering at the beginning of each sheet of writing paper. If you use some blank sheets of paper for notes that you do not wish to be marked, put a large X across the entire sheet and do not include it in your numbering.
8. At the end of the exam, arrange all sheets *in the following order*:
 - answer form
 - used sheets in order
 - the sheets you do not wish to be marked
 - unused sheets and the printed question

Place the papers inside the envelope and leave everything on your desk. **You are not allowed to take any sheets of paper and any material used in the experiment out of the room.**

ROTATING LIQUID

This experiment consists of three basic parts:

1. investigation of the profile of the rotating liquid's surface and the determination of the acceleration due to gravity,
2. investigation of the rotating liquid as an optical system,
3. determination of the refractive index of the liquid.

When a cylindrical container filled with a liquid rotates about the vertical axis passing through its center with a uniform angular velocity ω , the liquid's surface becomes parabolic (see Figure 1). At equilibrium, the tangent to the surface at the point $P(x, y)$ makes an angle θ with the horizontal such that

$$\tan \theta = \frac{\omega^2 x}{g} \quad \text{for } |x| \leq R \quad (1)$$

where R is the radius of the container and g is the acceleration due to gravity.

It can further be shown that for $\omega < \omega_{\max}$ (where ω_{\max} is the angular speed at which the center of the rotating liquid touches the bottom of the container)

$$\text{at } x=x_0 = \frac{R}{\sqrt{2}}, \quad y(x_0) = h_0 \quad (2)$$

that is, the height of the rotating liquid is the same as if it were not rotating.

The profile of the rotating liquid's surface is a parabola defined by the equation

$$y = y_0 + \frac{x^2}{4C} \quad (3)$$

where the vertex is at $V(0, y_0)$ and the focus is at $F(0, y_0 + C)$. When optical rays parallel to the axis of symmetry (optical axis) reflect at the parabolic surface, they all focus at the point F (see Fig.1).

Apparatus

- A cylindrical rigid plastic cup containing liquid glycerin. Millimetric scales are attached to the bottom and the sidewall of this cup.
- A turntable driven by a small dc electric motor powered by a variable voltage supply, which controls the angular velocity.
- A transparent horizontal screen on which you can put transparent or semi-transparent millimetric scales. The location of the screen can be adjusted along the vertical and horizontal directions.
- A laser pointer mounted on a stand. The position of the pointer can be adjusted. The head of the pointer can be changed.
- Additional head for the laser pointer.
- A ruler.
- A highlighter pen.
- A stopwatch. Push the left button to reset, the middle button to select the mode, and the right button to start and stop the timing.
- Transmission gratings with 500 or 1000 lines/mm.
- Bubble level.
- Glasses.

IMPORTANT NOTES

- ***DO NOT LOOK DIRECTLY INTO THE LASER BEAM. BE AWARE THAT LASER LIGHT CAN ALSO BE DANGEROUS WHEN REFLECTED OFF A MIRROR-LIKE SURFACE. FOR YOUR OWN SAFETY USE THE GIVEN GLASSES.***
- *Throughout the whole experiment carefully handle the cup containing glycerin.*
- *The turntable has already been previously adjusted to be horizontal. Use bubble level only for horizontal alignment of the screen.*
- *Throughout the entire experiment you will observe several spots on the screen produced by the reflected and/or refracted beams at the various interfaces between the air, the liquid, the screen, and the cup. Be sure to make your measurements on the correct beam.*
- *In rotating the liquid change the speed of rotation gradually and wait for long enough times for the liquid to come into equilibrium before making any measurements.*

EXPERIMENT

PART 1: DETERMINATION of g USING a ROTATING LIQUID [7.5 pts]

- Derive Equation 1.
- Measure the height h_0 of the liquid in the container and the inner diameter $2R$ of the container.
- Insert the screen between the light source and the container. Measure the distance H between the screen and the turntable (see Figure 2).
- Align the laser pointer such that the beam points vertically downward and hits the surface of the liquid at a distance $x_0 = \frac{R}{\sqrt{2}}$ from the center of the container.
- Rotate the turntable slowly. Be sure that the center of the rotating liquid is not touching the bottom of the container.
- It is known that at $x_0 = \frac{R}{\sqrt{2}}$ the height of the liquid remains the same as the original height h_0 , regardless of the angular speed ω . Using this fact and measurements of the angle θ of the surface at x_0 for various values of ω , perform an experiment to determine the gravitational acceleration g .
- Prepare tables of measured and calculated quantities for each ω .
- Produce the necessary graph to calculate g .
- Calculate the value of g and the experimental error in it
- Copy the values $2R$, x_0 , h_0 , H and the experimental value of g and its error onto **the answer form**.

PART 2: OPTICAL SYSTEM

In this part of the experiment the rotating liquid will be treated as an image forming optical system. Since the curvature of the surface varies with the angular speed of rotation, the focal distance of this optical system depends on ω .

2a) Investigation of the focal distance [5.5 pts]

- Align the laser pointer such that the laser beam is directed vertically downward at the center of the container. Mark the point P where the beam strikes the screen. Thus the line joining this point to the center of the cup is the optical axis of this system (see Figure 2).
- Since the surface of the liquid behaves like a parabolic mirror, any incident beam parallel to the optical axis will pass through the focal point F on the optical axis after reflection.
- Adjust the speed of rotation to locate the focal point on the screen. Measure the angular speed of rotation ω and the distance H between the screen and the turntable.
- Repeat the above steps for different H values.
- Copy the measured values of $2R$ and h_0 and the value of ω at each H onto the **answer form**.
- With the help of an appropriate graph of your data, find the relationship between the focal length and the angular speed. Copy your result onto the **answer form**.

2b) Analysis of the “image” (what you see on the screen) [3.5 pts]

In this part of the experiment the properties of the “image” produced by this optical system will be analyzed. To do so, follow the steps given below.

- Remove the head of the laser pointer by turning it counterclockwise.
- Mount the new head (provided in an envelope) by turning it clockwise. Now your laser produces a well defined shape rather than a narrow beam.
- Adjust the position of the laser pointer so that the beam strikes at about the center of the cup almost normally.
- Put a semitransparent sheet of paper on the horizontal screen, which is placed close to the cup, such that the laser beam does not pass through the paper, but the reflected beam does.
- Observe the size and the orientation of the “image” produced by the source beam and the beam reflected from the liquid when it is not rotating.
- Start the liquid rotating, and increase the speed of rotation gradually up to the maximum attainable speed while watching the screen. As ω increases you might observe different frequency ranges over which the properties of the “image” are drastically different. To describe these observations **complete the table** on the **answer form** by adding a row to this table for each such frequency range and fill it in by using the appropriate notations explained on that page.

PART 3: REFRACTIVE INDEX [3.5 pts]

In this part of the experiment the refractive index of the given liquid will be determined using a grating. When monochromatic light of wavelength λ is incident normally on a diffraction grating, the maxima of the diffraction pattern are observed at angles α_m given by the equation

$$m\lambda = d \sin \alpha_m \quad (4)$$

where, m is the order of diffraction and d is the distance between the rulings of the grating. In this part of the experiment a diffraction grating will be used to determine the wavelength of the laser light and the refractive index of the liquid (see Figure 3).

- Use the grating to determine the wavelength of the laser pointer. Copy your result onto the **answer form**.
- Immerse the grating perpendicularly into the liquid at the center of the cup.
- Align the laser beam such that it enters the liquid from the sidewall of the cup and strikes the grating normally.
- Observe the diffraction pattern produced on the millimetric scale attached to the cup on the opposite side. Make any necessary distance measurements.
- Calculate the refractive index n of the liquid by using your measurements. (Ignore the effect of the plastic cup on the path of the light.)
- Copy the result of your experiment onto the **answer form**.

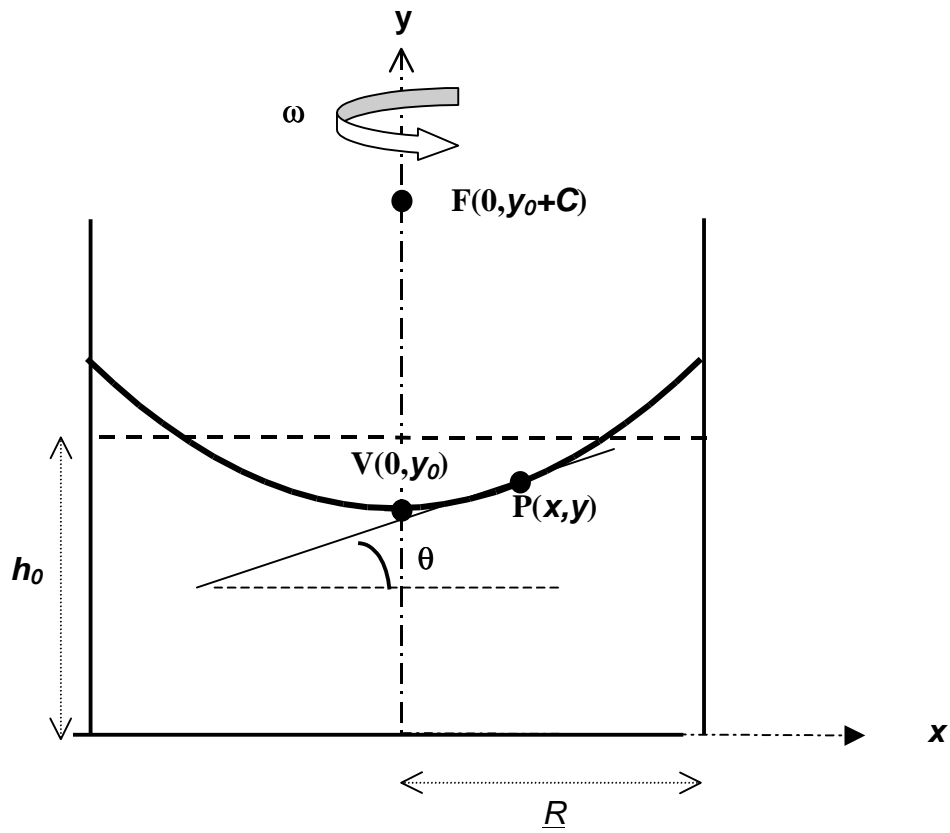

Figure 1. Definitions of the bank angle θ at point $P(x, y)$, the vertex V and the focus F for the parabolic surface produced by rotating the liquid, of initial height h_0 and radius R , at a constant angular speed ω around the y -axis.

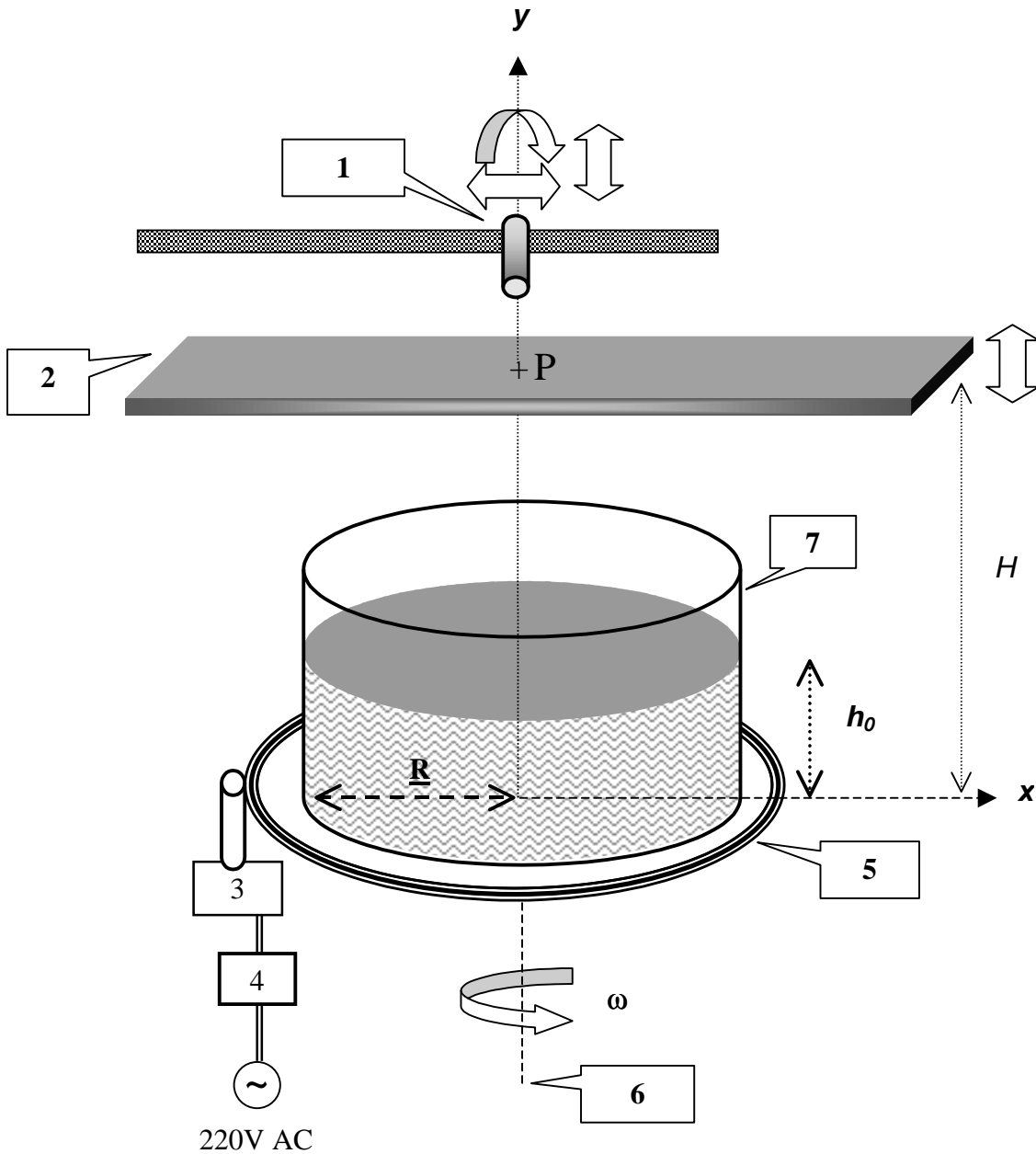

Figure 2 Experimental setup for parts 1 and 2.

1. Laser pointer on a stand, 2. Transparent screen, 3. Motor, 4. Motor controller, 5. Turntable, 6. Axis of rotation, 7. Cylindrical container.

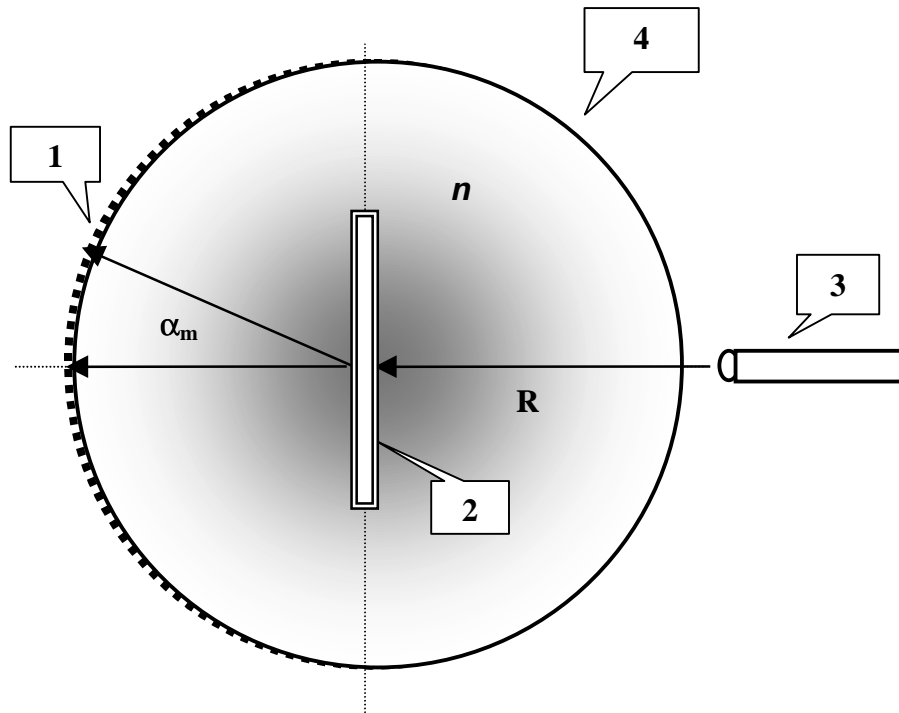

Figure 3 Top view of the grating in a liquid experiment.

1. Scaled sidewall, 2. Grating on a holder, 3. Laser pointer, 4. Cylindrical container.

Country no	Country code	Student No.	Question No.	Page No.	Total No. of pages

ANSWER FORM

1) Determination of g using a rotating liquid

$2R$	x_0	h_0	H

Experimental value of g :

2a) Investigation of the focal distance

$2R$	h_0

H	ω

Relation between focal length and ω :

Country no	Country code	Student No.	Question No.	Page No.	Total No. of pages

2b) Analysis of the “image”

Use the appropriate notations explained below to describe what you see on the screen due to reflected beam

ω range: For the frequency ranges only approximate values are required.

Orientation (in comparison with the object beam as seen on the transparent screen):

Inverted : **INV**

Erect : **ER**

Variation of the size with increasing ω :

Increases : **I**

Decreases : **D**

No change : **NC**

For the frequency ranges you have found above:

Write “**R**” if the screen is above the focal point.

Write “**V**” if the screen is below the focal point.

ω Range	Orientation	Variation of the size	“image”
$\omega=0$			

3) Refractive index

Wavelength =

Experimental value for n =

Solution

Part 1a

$$a. \quad v_{ret} = \sqrt{v_0^2 - 2(e/m)V} = 1.956 \times 10^6 \text{ m/s} \quad (0.5 \text{ pts})$$

$$v_{acc} = \sqrt{v_0^2 + 2(e/m)V} = 2.044 \times 10^6 \text{ m/s}$$

$$x_{ret} = v_{ret}t, \quad x_{acc} = v_{acc}(t - T/2) \quad (0.5 \text{ pts})$$

$$x_{ret} = x_{acc} \rightarrow t_{bunch} = \frac{v_{acc}T}{2(v_{acc} - v_{ret})} = 11.61T \quad (0.3 \text{ pts})$$

$$b = v_{ret}t_{bunch} = 2.272 \times 10^{-2} \text{ m.} \quad (0.2 \text{ pts})$$

b. The phase difference:

$$\Delta\phi = \pm \left(\frac{t_{bunch}}{T} - n \right) 2\pi = \pm 0.61 \times 2\pi = \pm 220^\circ. \quad (1.0 \text{ pts})$$

OR

$$\Delta\phi = \pm 140^\circ$$

Part 1b

$$\rho_L = n_L \frac{M}{N_A} \quad (0.3 \text{ pts})$$

where n_L is the number of molecules per cubic meter in the liquid phase

Average distance between the molecules of water in the liquid phase:

$$d_L = (n_L)^{-1/3} = \left(\frac{M}{\rho_L N_A} \right)^{1/3} \quad (0.2 \text{ pts})$$

$$P_a V = nRT,$$

where n is the number of moles (0.6 pts)

$$P_a = \frac{nM}{V} \frac{RT}{M} = \rho_V \frac{RT}{M} = \frac{n_V M}{N_A} \frac{RT}{M}$$

where n_V is the number of molecules per cubic meter in the vapor phase. (0.9 pts)

$$d_V = (n_V)^{-1/3} = \left(\frac{RT}{P_a N_A} \right)^{1/3} \quad (0.2 \text{ pts})$$

$$\frac{d_V}{d_L} = \left(\frac{RT \rho_L}{P_a M} \right)^{1/3} = 12 \quad (0.3 \text{ pts})$$

Part 1c

a.

(0.5 pts.)

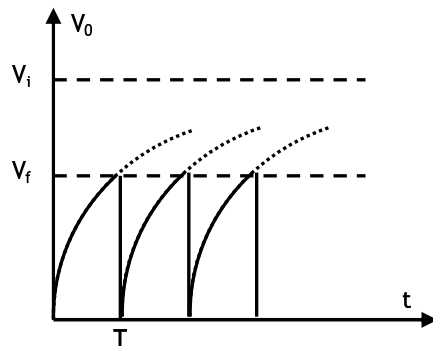

b. $V_i \gg V_f$ (0.2 pts)

c. $V_f = V_i(1 - e^{-T/RC})$

(0.2 pts)

If

$$V_i \gg V_f,$$

$$T/RC \ll 1,$$

$$e^{-T/RC} \approx 1 - (T/RC)$$

then

$$T = (V_f / V_i) RC$$

(0.2 pts)

d. R

(0.2 pts)

e. SG and R

(0.2 pts)

f. Correct circuit

(0.4 pts)

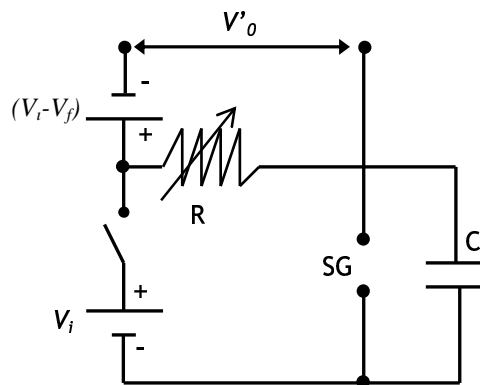

V'_0

(0.3 pts)

$V'_i - V_f$ with the correct polarity

(0.3 pts)

Total

(1.0 pts)

Part 1d

As the beam passes through a hole of diameter D the resulting uncertainty in the y -component of the momentum;

$$\Delta p_y \approx \frac{\hbar}{D} \quad (0.6 \text{ pts})$$

and the corresponding velocity component;

$$\Delta v_y \approx \frac{\hbar}{MD} \quad (0.4 \text{ pts})$$

Diameter of the beam grows larger than the diameter of the hole by an amount

$$\Delta D = \Delta v_y \cdot t,$$

where t is the time of travel. (0.2 pts)

If the oven temperature is T , a typical atom leaves the hole with kinetic energy

$$KE = \frac{1}{2} Mv^2 = \frac{3}{2} kT \quad (0.4 \text{ pts})$$

$$v = \sqrt{\frac{3kT}{M}} \quad (0.2 \text{ pts})$$

Beam travels the horizontal distance L at speed v in time

$$t = \frac{L}{v}, \text{ so} \quad (0.2 \text{ pts})$$

$$\Delta D = t\Delta v_y \approx \frac{L}{v} \frac{\hbar}{MD} = \frac{L\hbar}{MD\sqrt{\frac{3kT}{M}}} = \frac{L\hbar}{D\sqrt{3MkT}} \quad (0.4 \text{ pts})$$

Hence the new diameter after a distance L will be;

$$D_{\text{new}} = D + \frac{L\hbar}{D\sqrt{3MkT}} \quad (0.1 \text{ pts})$$

Part 2a

The total energy radiated per second = $4\pi R^2 \sigma T^4$, where σ is the Stephan-Boltzmann constant. The energy incident on a unit area on earth per second is;

$$P = \frac{4\pi R^2 \sigma T^4}{4\pi \ell^2} \text{ yielding, } R = \left(P / \sigma T^4 \right)^{1/2} \ell \quad (1) \quad (0.8 \text{ pts})$$

The energy of a photon is $hf = hc/\lambda$. The equivalent mass of a photon is $h/c\lambda$. Conservation of photon energy:

$$\frac{hc}{\lambda_0} - \frac{Gm_0}{R} \cdot \frac{h}{c\lambda_0} = \frac{hc}{\lambda} \quad (0.8 \text{ pts})$$

yielding

$$R = \frac{Gm_0(\lambda_0 + \Delta\lambda)}{c^2 \Delta\lambda} \quad (2)$$

and (2) yields,

$$m_0 = \frac{c^2 \Delta\lambda (P / \sigma T^4)^{1/2}}{G(\lambda_0 + \Delta\lambda)} \ell \quad (3) \quad (0.2 \text{ pts})$$

The stars are rotating around the center of mass with equal angular speeds:

$$\omega = (2\pi/2\tau) = \pi/\tau \quad (4) \quad (0.2 \text{ pts})$$

The equilibrium conditions for the stars are;

$$\frac{GMm_0}{(r_1 + r_2)^2} = m_0 r_1 \omega^2 = M r_2 \omega^2 \quad (5) \quad (0.8 \text{ pts})$$

with

$$r_1 = \ell \frac{\Delta\theta}{2}, \quad r_2 = \ell \frac{\Delta\phi}{2} \quad (6) \quad (0.4 \text{ pts})$$

Substituting (3), (4) and (6) into (5) yields

$$\ell = \left(\frac{8c^2 \Delta\lambda (P / \sigma T^4)^{1/2}}{\Delta\phi(\pi/\tau)^2 (\lambda_0 + \Delta\lambda) (\Delta\theta + \Delta\phi)^2} \right)^{1/2} \quad (0.8 \text{ pts})$$

Part 2b

Conservation of angular momentum for the ordinary star;

$$mr^2 \omega = m_0 r_0^2 \omega_0 \quad (7) \quad (0.6 \text{ pts.})$$

Conservation of angular momentum for dm :

$$r^2 \omega dm = r_f^2 \omega_f dm \quad (8) \quad (0.6 \text{ pts})$$

where ω_f is the angular velocity of the ring. Equilibrium in the original state yields,

$$\omega_0 = \left(\frac{GM}{r_0^3} \right)^{1/2} \quad (9) \quad (0.8 \text{ pts})$$

and (7), (8) and (9) give,

$$\omega = \frac{m_0 r_0}{m r^2} \left(\frac{GM}{r_0} \right)^{1/2}, \quad \omega_f = \frac{m_0 r_0}{m r_f^2} \left(\frac{GM}{r_0} \right)^{1/2} \quad (10) \quad (0.4 \text{ pts})$$

Conservation of energy for dm;

$$\frac{1}{2} dm (v_0^2 + r^2 \omega^2) - \frac{GM dm}{r} = \frac{1}{2} dm r_f^2 \omega_f^2 - \frac{GM dm}{r_f} \quad (11) \quad (1.2 \text{ pts})$$

Substituting (10);

$$v_0^2 + \frac{m_0^2 r_0 GM}{m^2} \left(\frac{1}{r^2} - \frac{1}{r_f^2} \right) - 2GM \left(\frac{1}{r} - \frac{1}{r_f} \right) = 0 \quad (12)$$

Since $r_0 \gg r_f$, if $r > r_0$, r^{-1} and r^{-2} terms can be neglected. Hence,

$$r_f = \frac{GM}{v_0^2} \left(\left(1 + \frac{m_0^2 r_0 v_0^2}{GM m^2} \right)^{1/2} - 1 \right). \quad (0.8 \text{ pts})$$

To show that $r > r_0$ change in the linear momentum of the ordinary star in its reference frame:

$$-\frac{GMm}{r^2} + m r \omega^2 - m \frac{dv_r}{dt} = -v_0 \frac{dm_{gas}}{dt} \quad (13) \quad (0.8 \text{ pts})$$

and (13) implies the existence of an outward force initially and hence r starts growing. Using (7) one can write

$$m r \omega^2 = \frac{m_0^2 r_0^4 \omega_0^2}{m r^3}.$$

Hence, $\frac{\text{Gravitational force}}{\text{Centrifugal force}} \propto m^2 r$. (0.4 pts)

where m is definitely decreasing. If r starts decreasing at some time also, this ratio starts decreasing, which is a contradiction.

So $r > r_0$. (0.4 pts)

Part 3a

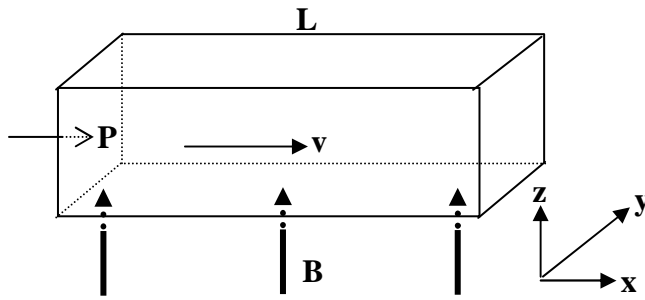

The net force on a charged particle must be zero in the steady state

$$\vec{F} = 0 = q\vec{E} + q\vec{v} \times \vec{B}$$

$$\vec{E} = -\vec{v} \times \vec{B} = vB \hat{y} \quad (0.4 \text{ pts})$$

$$V_H = vBw$$

$$I = \frac{V_H}{R} = \frac{V_H}{\frac{\rho w}{Lh}} = \frac{vBwLh}{\rho w} = \frac{vBLh}{\rho}, \text{ direction: } -\hat{y} \quad (0.6 \text{ pts})$$

$$\vec{F} = I \vec{\ell} \times \vec{B} = \frac{vB^2 Lhw}{\rho}, \text{ direction: } (-\hat{y} \times \hat{z} = -\hat{x})$$

Force is in the -x direction (0.8 pts)

This creates a back pressure P_b

$$P_b = \frac{vB^2 Lhw}{\rho hw} = \frac{vB^2 L}{\rho} \quad (0.6 \text{ pts})$$

$$F_{\text{net}} = (P - P_b)hw, \quad (0.6 \text{ pts})$$

$$v = \alpha F_{\text{net}} \quad (0.4 \text{ pts})$$

$$v = \alpha(P - P_b)hw = \alpha \left(P - \frac{vB^2 L}{\rho} \right) \frac{v_0}{\alpha P} = v_0 - \frac{v v_0 B^2 L}{P\rho}$$

$$v \left(1 + \frac{v_0 B^2 L}{P\rho} \right) = v_0$$

$$v = v_0 \left(1 + \frac{v_0 B^2 L}{P\rho} \right)^{-1}$$

$$v = v_0 \frac{P\rho}{P\rho + v_0 B^2 L} \quad (0.6 \text{ pts})$$

Part 3b

From conservation of energy:

$$\Delta Power = V_H I = \frac{v_0^2 B^2 whL}{\rho}$$

or,

to recover v_0 the pump must supply an additional pressure $\Delta P = P_b$

(1.0 pts)

$$\Delta Power = \Delta P h w v_0 = P_b h w v_0 = \frac{v_0^2 B^2 whL}{\rho}$$

Part 3c

$$1. \quad u = \frac{c}{n} \quad u' = \frac{\frac{c}{n} + v}{1 + \frac{c}{n} \frac{v}{c^2}} = \frac{\frac{c}{n} + v}{1 + \frac{v}{cn}} \quad (0.5 \text{ pts})$$

For small v ($v \ll c$);

neglect the terms containing $\frac{v^2}{c^2}$ in the expansion of $(1 + \frac{v}{cn})^{-1}$

$$u' = \left(\frac{c}{n} + v\right) \frac{1}{1 + \frac{v}{cn}} \approx \left(\frac{c}{n} + v\right) \left(1 - \frac{v}{cn}\right) \approx \frac{c}{n} + v \left(1 - \frac{1}{n^2}\right)$$

$$\Delta u = u' - u \approx v \left(1 - \frac{1}{n^2}\right) \quad (0.5 \text{ pts})$$

$$\Delta \phi = 2\pi f \Delta T, \quad T = \frac{L}{u}, \quad \Delta T = \frac{\Delta u}{u^2} L \approx \frac{Lv}{c^2} (n^2 - 1) \quad (0.5 \text{ pts})$$

$$v = v_0 \text{ so that, } \Delta \phi = 2\pi f \frac{L}{c^2} (n^2 - 1) v_0 \quad (0.5 \text{ pts})$$

$$2. \quad \Delta \phi = 2\pi f \frac{L}{c^2} (n^2 - 1) v_0 \quad (0.4 \text{ pts})$$

a phase of $\pi/36$ results in

$$v_0 = \frac{c^2}{72L(n^2 - 1)f} \quad (0.2 \text{ pts})$$

$$v_0 = \frac{9 \times 10^{16}}{72 \times 10^{-1} \times (2.56 - 1) \times 25} = 3.2 \times 10^{14} \text{ m/s which is not physical.} \quad (0.4 \text{ pts})$$

3. For $v=20$ m/s, $f\approx 4\times 10^{14}$ Hz. But for this value of f , skin depth is about 25 nm. This means that amplitude of the signal reaching the end of the tube is practically zero. Therefore mercury should be replaced with water. (0.6 pts)

On the other hand if water is used instead of mercury, at 25 Hz $\delta\approx 3\times 10^5$ m. Signal reaches to the end but $v\approx 6\times 10^{14}$ m/s, is still nonphysical. Therefore frequency should be readjusted. (0.6 pts)

For $v=20$ m/s electromagnetic wave of $f\approx 8\times 10^{14}$ Hz has a skin depth of about $\delta\approx 5.6$ cm in water and the emerging wave is out of phase by $\pi/36$ with respect to the incident wave. (The amplitude of the wave reaching to the end of the section is about 17% of the incident amplitude). (0.6 pts)

Therefore mercury should be replaced with water and frequency should be adjusted to $f\approx 8\times 10^{14}$ Hz. The correct choice is (iii) (0.2 pts)

Solution

Part 1

Theory:

Consider a small mass m of the liquid at the surface (Figure 4).
At dynamic equilibrium

$$N \cos\theta = mg$$

and

$$N \sin\theta = mw^2x$$

Therefore:

$$\tan\theta = \frac{w^2x}{g}$$

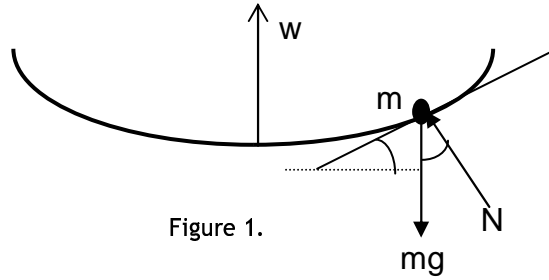

Figure 1.

The profile of the liquid surface can be found as follows:

$$\tan\theta = \frac{dy}{dx}, \quad \frac{dy}{dx} = \frac{w^2x}{g}$$

so that

$$y = \frac{w^2x^2}{2g} + y_0$$

where y_0 is the height at $x = 0$.

At a certain point $x = x_0$, height of the liquid h_0 would be the same as if it not rotating.

In this case,

$$h_0 = y_0 + \frac{w^2x_0^2}{2g} \tag{1}$$

and,

$$x_0^2 = \frac{2g(h_0 - y_0)}{w^2}$$

Since the volume of the liquid is constant,

$$\pi R^2 h_0 = \int y(2\pi x dx) = 2\pi \int (y_0 + \frac{w^2x^2}{2g})x dx,$$

$$y_0 = h_0 - \frac{w^2R^2}{4g} \tag{2}$$

From Eq.1 and Eq.2 one obtains

$$x_0 = \frac{R}{\sqrt{2}}$$

Experiment:

$2R(\text{mm})$	$x_0(\text{mm})$	$h_0(\text{mm})$	$H(\text{mm})$
145	51	30	160

$H-h_0=130$ mm

Measure 10T at small speeds and measure 15T-20T at high speeds.

Use $\tan(2\theta) = \frac{x}{H-h_0}$ and $w = \frac{2\pi}{T}$.

$2R(\text{mm})$	$x_0(\text{mm})$	$h_0(\text{mm})$	$H(\text{mm})$	$H-h_0(\text{mm})$
145	51	30	160	130

$x(\text{mm})$	10T(s)	$w(\text{rad/s})$	$\tan(2\theta)$	$\theta(\text{rad})$	$\theta(\text{deg})$	$\tan(\theta)$	$w^2(\text{rad/s})^2$	
11	21.34	2.94	0.08	0.04	2.4	0.04	8.67	
20	15.80	3.98	0.15	0.08	4.4	0.08	15.81	
26	14.22	4.42	0.20	0.10	5.7	0.10	19.52	
30	12.99	4.84	0.23	0.11	6.5	0.11	23.40	
40	11.74	5.35	0.31	0.15	8.6	0.15	28.64	
51	10.45	6.01	0.39	0.19	10.7	0.19	36.15	
56	9.90	6.35	0.43	0.20	11.7	0.21	40.28	
65	9.40	6.68	0.50	0.23	13.3	0.24	44.68	
70	9.08	6.92	0.54	0.25	14.2	0.25	47.88	
85	8.39	7.49	0.65	0.29	16.6	0.30	56.08	
100	7.71	8.15	0.77	0.33	18.8	0.34	66.41	
112	7.43	8.46	0.86	0.36	20.4	0.37	71.51	
132	7.00	8.98	1.02	0.40	22.7	0.42	80.57	
61.4	11.19	6.20	0.47	0.21	11.98	0.21	41.51	Ave.

The last line is for error calculation only.

The slope of the Figure 5 is 0.0052 (s/rad)^2 which gives

$$g = \frac{x_0}{\text{slope}} = \frac{5.1}{0.0052} = 980 \text{ cm/s}^2.$$

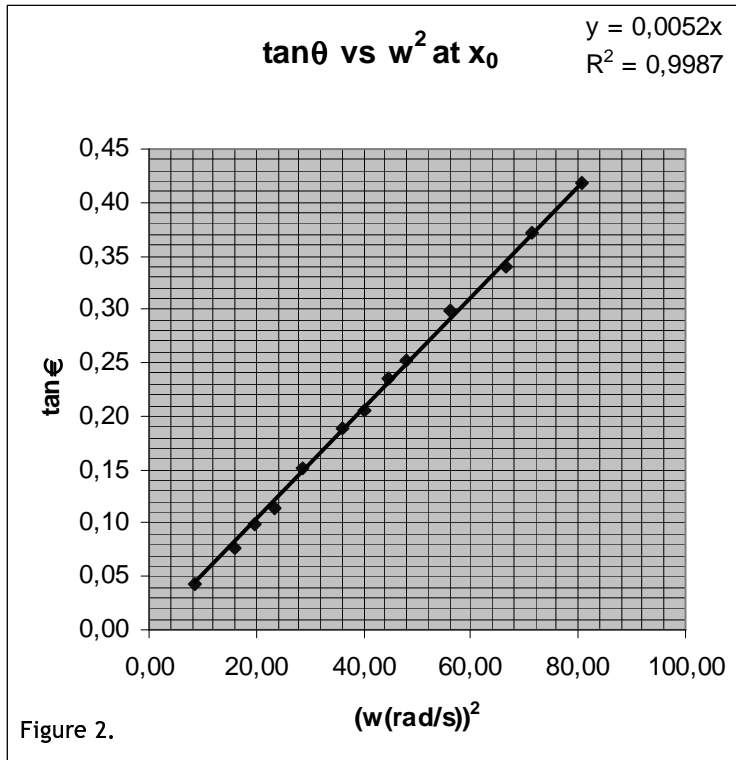

Error Calculation (possible methods):

$$g = \frac{w^2 x_0}{\tan \theta}$$

$$\frac{\Delta g}{g} = \sqrt{4 \left(\frac{\Delta w}{w} \right)^2 + \left(\frac{\Delta x_0}{x_0} \right)^2 + \left(\frac{\Delta(\tan \theta)}{\tan \theta} \right)^2} \quad \frac{\Delta w}{w} = \frac{\Delta T}{T}$$

$$\frac{\Delta(\tan \theta)}{\tan \theta} \approx \frac{\Delta \theta}{\theta}$$

(since from the table $\tan \theta \cong \theta$)

$$\theta \approx \frac{x}{H - h_0}, \quad \frac{\Delta \theta}{\theta} = \sqrt{\left(\frac{\Delta x}{x} \right)^2 + \left(\frac{\Delta H + \Delta h_0}{H - h_0} \right)^2}$$

$$\frac{\Delta g}{g} = \sqrt{4 \left(\frac{\Delta T}{T} \right)^2 + \left(\frac{\Delta x_0}{x_0} \right)^2 + \left(\frac{\Delta x}{x} \right)^2 + \left(\frac{\Delta H + \Delta h_0}{H - h_0} \right)^2}$$

Using the values $H=160$ mm, $\Delta H=1$ mm, $h_0=30$ mm, $\Delta h_0=1$ mm, $x_{av}=61.4$ mm, $\Delta x_{av}=1$ mm, $T_{av}=1.1$ s, $\Delta T=0.01$ s, $x_0=51$ mm, $\Delta x_0=1$ mm one obtains

$$g = 980 \pm 34 \text{ cm/s}^2$$

- Note that from the method of least squares one obtains the following results:

$$g = 982 \text{ cm/s}^2 \text{ with a standard deviation of } \sigma = 33 \text{ cm/s}^2$$

- From the linear regression of the data slope $\tan\theta$ vs w^2 is found to be 0.052 with a standard error of 5.14×10^{-5} , therefore:

$$\frac{\Delta g}{g} = \sqrt{\left(\frac{\Delta(\text{slope})}{\text{slope}}\right)^2 + \left(\frac{\Delta x_0}{x_0}\right)^2} = 0.02$$

$$g = 980 \pm 20 \text{ cm/s}^2$$

Part 2a

H(mm)	10T(s)	w(rad/s)	lnw	H-h ₀ (mm)	ln(H-h ₀)
158	10.31	6.09	0.784921	128	2.107
209	13.19	4.76	0.677935	179	2.253
190	11.70	5.37	0.729994	160	2.204
150	9.80	6.41	0.806954	120	2.079
129	9.21	6.82	0.83392	99	1.996
119	8.75	7.18	0.856172	89	1.949
110	8.10	7.76	0.889695	80	1.903

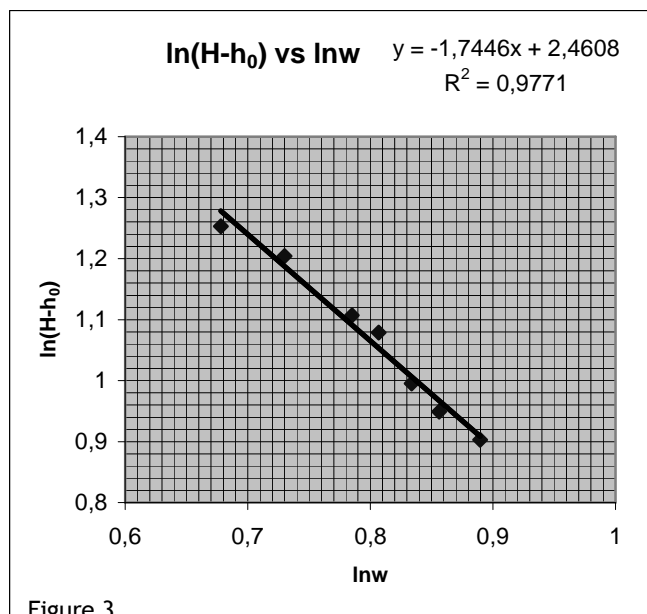

Thus the focal length depends on w as

$$f = Aw^n,$$

and

$$n \sim -1.7.$$

The plot of $H-h_0$ vs. $1/w^2$ is also acceptable as a correct plot.

Part 2b

ω Range(rad/s)	Orientation	Variation of the size	Image
$\omega=0$	ER		V
$0 < \omega < 8.2^*$ $0 < \omega < 6.3^{**}$	ER	D	V
$8.2 < \omega < 14.6^*$ $6.3 < \omega < 14.0^{**}$	INV	I	R
$14.6 < \omega < \omega_{\max}^*$ $14.0 < \omega < \omega_{\max}^{**}$	ER	NC	V

* for $H=110$ mm

** for $H=240$ mm

ω values depend on the initial values of H , h_0 , etc.

Note that measurements only at one H value are required from the students.

Part 3

Measurement of wavelength

Both the grating and the screen are in air. Normal incidence.

Screen to grating distance : L
Distance between the diffraction spots seen on the screen : x
Order of diffraction : m

- L= 225 mm, $x_{av}=77$ mm for m=±1 d=1/500 mm
$$\tan \alpha = \frac{x_{av}}{L} = \frac{77}{225}$$
$$\lambda = \frac{1}{500} \sin \alpha = 647 \text{ nm}$$
- L= 128 mm, $x_{av}=44$ mm for m=±1, d=1/500 mm
$$\tan \alpha = \frac{44}{128}$$
$$\lambda = \frac{1}{500} \sin \alpha = 650 \text{ nm}$$
- L= 128 mm, $x_{av}=111$ mm for m=±2, d=1/500 mm
$$\tan \alpha = \frac{111}{128}$$
$$\lambda = \frac{1}{2 \times 500} \sin \alpha = 655 \text{ nm}$$

The average value of λ is $\lambda_{av}=651$ nm.

Measurement of refractive index

$$2R=145 \text{ mm}$$

Distance between the spots measured on the curved screen = $R\alpha$

$$R\alpha_{av} = 17 \text{ mm} \quad \text{for } m=\pm 1 \quad \alpha_{av} = 0.234 \text{ rad}$$

using $n = \frac{m\lambda}{d \sin(\alpha)}$, one obtains $n=1.40$

If the curvature of the screen is neglected:

$$\tan \alpha = \frac{17}{72.5}$$

$$\alpha = 13.20^\circ$$

$$n = \frac{\lambda}{d \sin(\alpha)} = \frac{651(\text{nm})}{\frac{1}{500}(\text{mm}) \times 10^6 \sin(\alpha)} = 1.43$$

Grading Scheme for Experimental Competition

Part 1		7.5 pts
• Derivation of Equation 1		<u>1.0 pts</u>
• Calculation of ω using period measurements		<u>1.0 pts</u>
At low speeds 10T is OK		
<i>At high speeds 20T is expected</i>		<i>-0.2 pts</i>
<i>Missing units</i>		<i>-0.2 pts</i>
• Calculation of $\tan 2\theta$, $\tan \theta$ at each ω		<u>1.0 pts</u>
Calculation of $\tan 2\theta$		0.5 pts
Calculation of $\tan \theta$		0.5 pts
• Plot of $\tan \theta$ vs ω^2		<u>1.5 pts</u>
Axes with labels and units		0.4 pts
Drawing best fit line		0.5 pts
At least 6 different data in a wide range of ω		0.6 pts
<i>No. of measurements 5:</i>		<i>-0.2 pts</i>
<i>No of measurements 4:</i>		<i>-0.4 pts</i>
<i>No of measurements 3 or less:</i>		<i>-0.6 pts</i>
• Calculations		<u>2.0 pts</u>
calculation of slope with unit		1.0 pts
calculation of g		1.0 pts
<i>FULL credit for</i>		
<i>9.3 < g < 10.3 m/s² ($\pm 5\%$ error)</i>		
<i>For g values credits to be subtracted from the total credit of 7.5:</i>		
<i>10.3 < g < 10.5 m/s², 9.1 < g < 9.3 m/s²</i>		<i>-0.5 pts</i>
<i>8.8 < g < 9.1 m/s², 10.3 < g < 10.8 m/s²</i>		<i>-1.0 pts</i>
<i>outside the above ranges</i>		<i>-1.5 pts</i>
• Error Calculation		<u>1.0 pts</u>

Part 2a 5.5 pts

- Measurements of H vs ω 0.6 pts
Calculation of ω using period measurements 0.4 pts

At low speeds 10T is OK

At high speeds 20T is expected

H- ω table

-0.2 pts

0.2 pts

- Plot of F vs ω 2.4 pts
Calculation of $F=H-h_0$ 0.5 pts
Plot with axis labels 0.8 pts
Drawing best fit line 0.5 pts
At least 6 different data in a wide range of ω 0.6 pts

No. of measurements 5:

-0.2 pts

No of measurements 4:

-0.4 pts

No of measurements 3 or less:

-0.6 pts

- Calculations 2.5 pts
Calculation of slope with unit 1.0 pts
Dependence $F \propto 1/\omega^2$ 1.5 pts

Part 2b 3.5 pts

- Every correct item in the table 0.25 pts

Part 3 3.5 pts

(At least 3 measurements at different orders are required)

- Wavelength measurement 1.2 pts
Distance measurements and calculation of angle 0.6 pts
Calculation of λ 0.6 pts

Credits to be subtracted from the total credit of 1.2:

If λ is outside the range 600-700 nm

-0.4 pts

If less than 3 measurements

-0.4 pts

- Measurement of n 2.3 pts
Distance measurements and calculation of angle 0.6 pts
Realizing λ/n 0.8 pts
Calculation of n 0.9 pts

credits to be subtracted from the total credit of 2.3:

If n is outside range 1.3-1.6

-0.4 pts

If less than 3 measurements

-0.4 pts

I. Ground-Penetrating Radar

Ground-penetrating radar (GPR) is used to detect and locate underground objects near the surface by means of transmitting electromagnetic waves into the ground and receiving the waves reflected from those objects. The antenna and the detector are directly on the ground and they are located at the same point.

A linearly polarized electromagnetic plane wave of angular frequency ω propagating in the z direction is represented by the following expression for its field:

$$E = E_0 e^{-\mathbf{a}z} \cos(\mathbf{w}t - \mathbf{b}z), \quad (1)$$

where E_0 is constant, \mathbf{a} is the attenuation coefficient and \mathbf{b} is the wave number expressed respectively as follows

$$\mathbf{a} = \mathbf{w} \left\{ \frac{\mathbf{m}\mathbf{e}}{2} \left[\left(1 + \frac{\mathbf{S}^2}{\mathbf{e}^2 \mathbf{w}^2} \right)^{1/2} - 1 \right] \right\}^{1/2}, \quad \mathbf{b} = \mathbf{w} \left\{ \frac{\mathbf{m}\mathbf{e}}{2} \left[\left(1 + \frac{\mathbf{S}^2}{\mathbf{e}^2 \mathbf{w}^2} \right)^{1/2} + 1 \right] \right\}^{1/2} \quad (2)$$

with $\mathbf{m}\mathbf{e}$, and \mathbf{S} denoting the magnetic permeability, the electrical permittivity, and the electrical conductivity respectively.

The signal becomes undetected when the amplitude of the radar signal arriving at the object drops below $1/e$ ($\approx 37\%$) of its initial value. An electromagnetic wave of variable frequency (10 MHz – 1000 MHz) is usually used to allow adjustment of range and resolution of detection.

The performance of GPR depends on its resolution. The resolution is given by the minimum separation between the two adjacent reflectors to be detected. The minimum separation should give rise to a minimum phase difference of 180° between the two reflected waves at the detector.

Questions:

(Given : $\mathbf{m} = 4\pi \times 10^{-7}$ H/m and $\mathbf{e}_0 = 8.85 \times 10^{-12}$ F/m)

1. Assume that the ground is non-magnetic ($\mathbf{m}=\mathbf{m}_0$) satisfying the condition

$\left(\frac{\mathbf{S}}{\mathbf{w}\mathbf{e}} \right)^2 \ll 1$. Derive the expression of propagation speed v in terms of \mathbf{m} and \mathbf{e} , using equations (1) and (2) [1.0 pts].

2. Determine the maximum depth of detection of an object in the ground with conductivity of 1.0 mS/m and permittivity of $9\epsilon_0$, satisfying the condition $\left(\frac{S}{\omega\epsilon}\right)^2 \ll 1$, ($S = \text{ohm}^{-1}$; use $\mu = \mu_0$). [2.0 pts]
3. Consider two parallel conducting rods buried horizontally in the ground. The rods are 4 meter deep. The ground is known to have conductivity of 1.0 mS/m and permittivity of $9\epsilon_0$. Suppose the GPR measurement is carried out at a position approximately above one of the rod. Assume point detector is used. Determine the minimum frequency required to get a lateral resolution of 50 cm [3.5 pts].
4. To determine the depth of a buried rod d in the same ground, consider the measurements carried out along a line perpendicular to the rod. The result is described by the following figure:

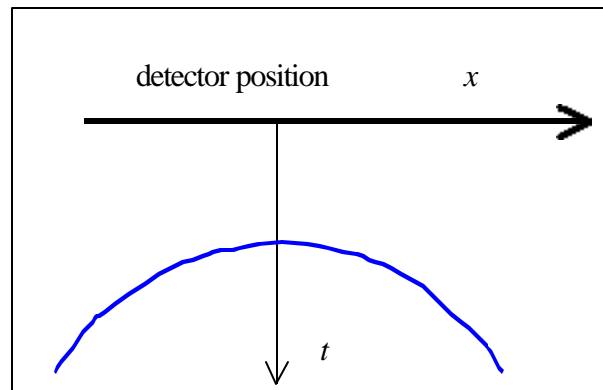

Graph of traveltime t vs detector position x , $t_{min} = 100$ ns.

Derive t as a function of x and determine d [3.5 pts].

II. Sensing Electrical Signals

Some seawater animals have the ability to detect other creatures at some distance away due to electric currents produced by the creatures during the breathing processes or other processes involving muscular contraction. Some predators use this electrical signal to locate their preys, even when buried under the sands.

The physical mechanism underlying the current generation at the prey and its detection by the predator can be modeled as described by Figure II-1. The current generated by the prey flows between two spheres with positive and negative potential in the prey's body. The distance between the centers of the two spheres is l_s , each having a radius of r_s , which is much smaller than l_s . The seawater resistivity is r . Assume that the resistivity of the prey's body is the same as that of the surrounding seawater, implying that the boundary surrounding the prey in the figure can be ignored.

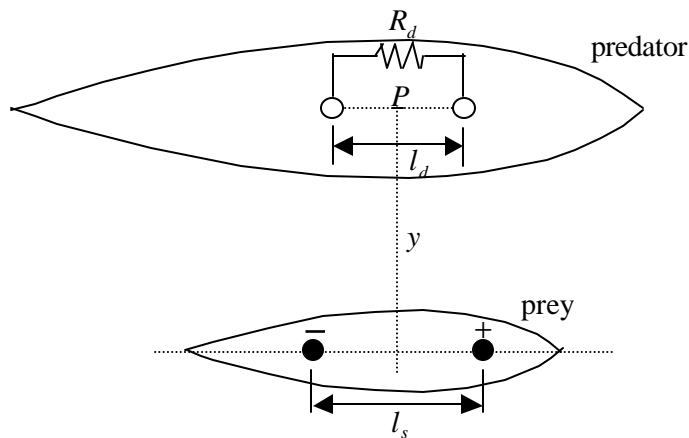

Figure II-1. A model describing the detection of electric power coming from a prey by its predator.

In order to describe the detection of electric power by the predator coming from the prey, the detector is modeled similarly by two spheres on the predator's body and in contact with the surrounding seawater, lying parallel to the pair in the prey's body. They are separated by a distance of l_d , each having a radius of r_d which is much smaller than l_d . In this case, the center of the detector is located at a distance y right above the source and the line connecting the two spheres is parallel to the electric field as shown in Figure II-1. Both l_s and l_d are also much smaller than y . The electric field strength along the line connecting the two spheres is assumed to be constant. Therefore the detector forms a closed circuit system connecting the prey, the surrounding seawater and the predator as described in Figure II-2.

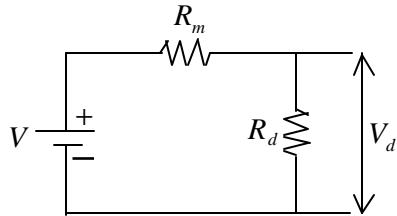

Figure II-2. The equivalent closed circuit system involving the sensing predator, the prey and the surrounding seawater.

In the figure, V is the voltage difference between the detector's spheres due to the electric field induced by the prey, R_m is the inner resistance due to the surrounding seawater. Further, V_d and R_d are respectively the voltage difference between the detecting spheres and the resistance of the detecting element within the predator.

Questions:

1. Determine the current density vector \vec{j} (current per unit area) caused by a point current source I_s at a distance r in an infinite medium [1.5 pts]

2. Based on the law $\vec{E} = \rho \vec{j}$, determine the electric field strength \vec{E}_p at the middle of the detecting spheres (at point P) for a given current I_s that flows between two spheres in the prey's body [**2.0 pts**].

3. Determine for the same current I_s , the voltage difference between the source spheres (V_s) in the prey [**1.5 pts**]. Determine the resistance between the two source spheres (R_s) [**0.5 pts**] and the power produced by the source (P_s) [**0.5 pts**].

4. Determine R_m [**0.5 pts**], V_d [**1.0 pts**] in Figure II-2 and calculate also the power transferred from the source to the detector (P_d) [**0.5 pts**].

5. Determine the optimum value of R_d leading to maximum detected power [**1.5 pts**] and determine also the maximum power [**0.5 pts**].

III. A Heavy Vehicle Moving on An Inclined Road

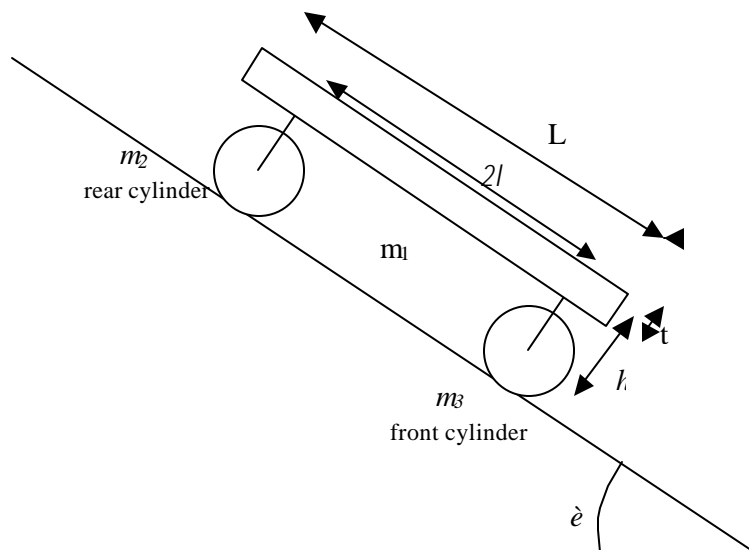

Figure III-1: A simplified model of a heavy vehicle moving on an inclined road.

The above figure is a simplified model of a heavy vehicle (road roller) with one rear and one front cylinder as its wheels on an inclined road with inclination angle of ϵ as shown in Figure III-1. Each of the two cylinders has a total mass $M(m_2=m_3=M)$ and consists of a cylindrical shell of outer radius R_o , inner radius $R_i = 0.8 R_o$ and eight number of spokes with total mass $0.2 M$. The mass of the undercarriage supporting the vehicle's body is negligible. The cylinder can be modeled as shown in Figure III-2. The vehicle is moving down the road under the influence of gravitational and frictional forces. The front and rear cylinder are positioned symmetrically with respect to the vehicle.

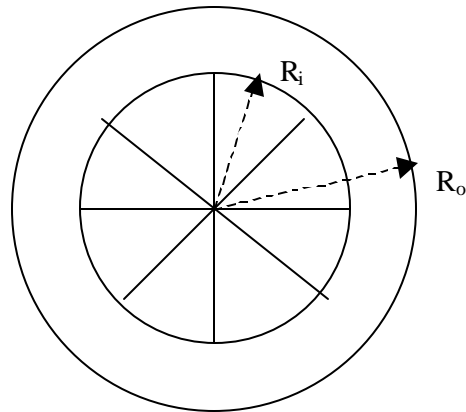

Figure III-2: A simplified model of the cylinders.

The static and kinetic friction coefficients between the cylinder *and* the road are μ_s and μ_k respectively. The body of the vehicle has a mass of $5M$, length of L and thickness of t . The distance between the front and the rear cylinder is $2l$ while the distance from the center of cylinder to the base of the vehicle's body is h . Assume that the rolling friction between the cylinder and its axis is negligible.

Questions:

1. Calculate the moment of inertia of either cylinder [1.5 pts].
2. Draw all forces that act on the body, the front cylinder, and the rear one. Write down equations of motion for each part of them [2.5 pts].
3. The vehicle is assumed to move from rest, then freely move under gravitational influence. State all the possible types of motion of the system and derive their accelerations in terms of the given physical quantities [4.0 pts].
4. Assume that after the vehicle travels a distance d by pure rolling from rest the vehicle enters a section of the road with all the friction coefficients drop to smaller constant values μ_s' and μ_k' such that the two cylinders start to slide. Calculate the linear and angular velocities of each cylinder after the vehicle has traveled a total distance of s meters. Here we assume that d and s is much larger than the dimension of vehicle [2.0 pts]

I. Determination of e/k_B Through Electrolysis Process

Background Theory

The electrolysis of water is described by the reaction :

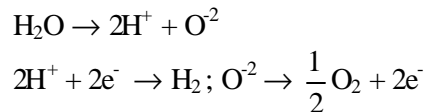

The reaction takes place when an electric current is supplied through a pair of electrodes immersed in the water. Assume that both gases produced in the reaction are ideal.

One of the gases produced by the reaction is kept in a test tube marked by arbitrary scale. By knowing the total charge transferred and the volume of the gas in the test tube the quantity e/k_B can be determined, where e is the charge of electron and k_B is the Boltzmann constant.

For the purpose mentioned above, this experiment is divided into two parts.

Part A: Calibration of the arbitrary scale on the test tube by using a dynamic method.

This result will be used for part B

Part B: Determination of the physical quantity e/k_B by means of water electrolysis

You are not obliged to carry out the two experiments (part A and part B) in alphabetical order

The following physical quantities are assumed:

- Acceleration of gravity, $g = (9.78 \pm 0.01) \text{ ms}^{-2}$
- Ratio of internal vs external diameters of the test tube, $\alpha = 0.82 \pm 0.01$

The local values of temperature T and pressure P will be provided by the organizer.

List of tools and apparatus given for experiment (part A & B):

- Insulated copper wires of three different diameters:
 1. Brown of larger diameter
 2. Brown of smaller diameter
 3. Blue
- A regulated voltage source (0-60 V, max.1A)
- A plastic container and a bottle of water.
- A block of brass with plastic clamp to keep the electrode in place without damaging the insulation of the wire.
- A digital stopwatch.
- A multimeter (beware of its proper procedure).
- A wooden test tube holder designed to hold the tube vertically.
- A multipurpose pipette

- A vertical stand.
- A bottle of white correction fluid for marking.
- A cutter
- A pair of scissors
- A roll of cellotape
- A steel ball
- A piece of stainless steel plate to be used as electrode.
- A test tube with scales.
- Graph papers.

Note that all scales marked on the graph papers and the apparatus for the experiments (e.g. the test tube) are of the same scale unit, but *not calibrated* in millimeter.

EXPERIMENT

Part A: Calibration of the arbitrary scale on the test tube

- Determine a dynamic method capable of translating the arbitrary length scale to a known scale available.
- Write down an expression that relates the measurable quantities from your experiment in terms of the scale printed on the test tube, and sketch the experiment set up.
- Collect and analyze the data from your experiment for the determination and calibration of the unknown length scale.

Part B: Determination of physical quantity e/k_B

- Set up the electrolysis experiment with a proper arrangement of the test tube in order to trap one of the gases produced during the reaction.
- Derive an equation relating the quantities: time t , current I , and water level difference Dh , measured in the experiment.
- Collect and analyze the data from your experiment. For simplicity, you may assume that the gas pressure inside the tube remains constant throughout the experiment.
- Determine the value of e/k_B .

Country	Student No.	Experiment No.	Page No.	Total Pages

ANSWER FORM**PART A**

1. State the method of your choice and sketch the experimental set up of the method: **[0.5 pts]**
2. Write down the expression relating the measurable quantities in your chosen method: **[0.5 pts]**. State all the approximations used in obtaining this expression **[1.0 pts]**.
3. Collect and organize the data in the following orders : physical quantities, values, units **[1.0 pts]**
4. Indicate the quality of the calibration by showing the plot relating two independently measured quantities and mark the range of validity. **[0.5 pts]**
5. Determine the smallest unit of the arbitrary scale in term of mm and its estimated error induced in the measurements. **[1.5 pts]**

Country	Student No.	Experiment No.	Page No.	Total Pages

PART B

1. Sketch of the experimental set up. **[1.0 pts]**

2. Derive the following expression:

$$I \Delta t = \frac{e}{k_B} \frac{2P(\rho r^2)}{T} \Delta h \quad \mathbf{[1.5 pts]}$$

3. Collect and organize the data in the following format : physical quantities (value, units) **[1.0 pts]**

4. Determine the value of e/k_B and its estimated error **[1.5 pts]**

II. OPTICAL BLACK BOX

Description

In this problem, the students have to identify the unknown optical components inside the cubic box. The box is sealed and has only two narrow openings protected by red plastic covering. The components should be identified by means of optical phenomena observed in the experiment. Ignore the small thickness effect of the plastic covering layer.

A line going through the centers of the slits is defined as the axis of the box. Apart from the red plastic coverings, there are three (might be identical or different) **elements from the following list**:

- Mirror, either plane or spherical
- Lens, either positive or negative
- Transparent plate having parallel flat surfaces (so called plane-parallel plate)
- Prism
- Diffraction grating.

The transparent components are made of material with a refractive index of 1.47 at the wavelength used.

Apparatus available:

- A laser pointer with a wavelength of 670 nm. **CAUTION: DO NOT LOOK DIRECTLY INTO THE LASER BEAM.**
- An optical rail
- A platform for the cube, movable along the optical rail
- A screen which can be attached to the end of the rail, and detached from it for other measurements.
- A sheet of graph paper which can be pasted on the screen by cellotape.
- A vertical stand equipped with a universal clamp and a test tube with arbitrary scales, which are also used in the Problem I.

Note that all scales marked on the graph papers and the apparatus for the experiments are of the same scale unit, but ***not calibrated*** in millimeter.

The Problem

Identify each of the three components and give its respective specification:

Possible type of component	Specification required
mirror	radius of curvature, angle between the mirror axis and the axis of the box
lens*	positive or negative, its focal length, and its position inside the box
plane-parallel plate	thickness, the angle between the plate and the axis of the box
prism	apex angle, the angle between one of its deflecting sides and the axis of the box
diffraction grating*	line spacing, direction of the lines, and its position inside the box

- implies that its plane is at right angle to the axis of the box

Express your final answers for the specification parameters of each component (e.g. focal length, radius of curvature) in terms of millimeter, micrometer or the scale of graph paper.

You don't have to determine the accuracy of the results.

Country	Student No.	Experiment No.	Page No.	Total Pages

ANSWER FORM

1. Write down the types of the optical components inside the box :

no.1. [0.5 pts]

no.2.. [0.5 pts]

no.3. [0.5 pts]

2. The cross section of the box is given in the figure below. Add a sketch in the figure to show how the three components are positioned inside the box. In your sketch, denote each component with its code number in answer 1 .

[0.5 pts for each correct position]

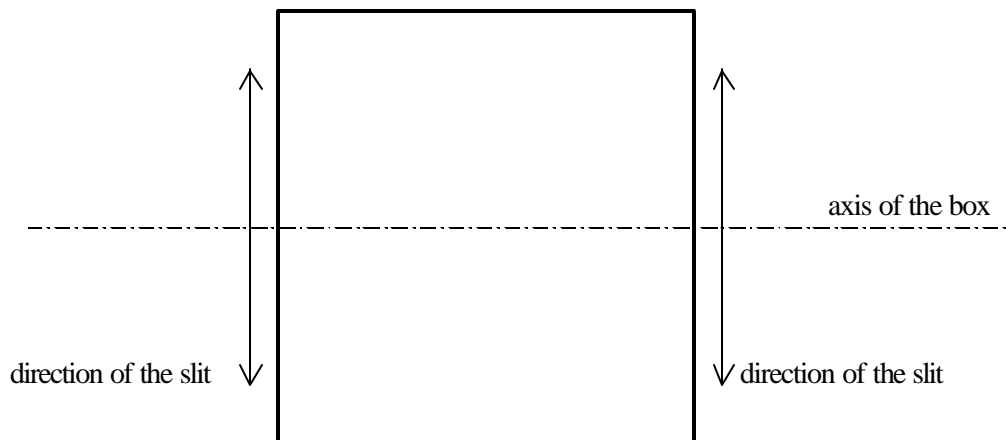

Country	Student No.	Experiment No.	Page No.	Total Pages

3. Add detailed information with additional sketches regarding arrangement of the optical components in answer 2, such as the angle, the distance of the component from the slit, and the orientation or direction of the components. [*1.0 pts*]

Country	Student No.	Experiment No.	Page No.	Total Pages

4. Summarize the observed data [*0.5 pts*], determine the specification of the optical component no.1 by deriving the appropriate formula with the help of drawing [*1.0 pts*], calculate the specifications in question and enter your answer in the box below [*0.5 pts*].

Name of component no.1	Specification

Country	Student No.	Experiment No.	Page No.	Total Pages

5. Summarize the observed data [*0.5 pts*], determine the specification of the optical component no.2 by deriving the appropriate formula with the help of drawing [*1.0 pts*], calculate the specifications in question and enter your answer in the box below [*0.5 pts*].

Name of component no.2	Specification

Country	Student No.	Experiment No.	Page No.	Total Pages

6. Summarize the observed data [*0.5 pts*], determine the specification of the optical component no.3 by deriving the appropriate formula with the help of drawing [*1.0 pts*], calculate the specifications in question and enter your answer in the box below [*0.5 pts*].

Name of component no.3	Specification



THEORETICAL COMPETITION

Tuesday, July 23rd, 2002

Solution I: Ground-Penetrating Radar

1. Speed of radar signal in the material v_m :

$$\mathbf{w} - \mathbf{b}z = \text{constant} \rightarrow \mathbf{b}z = -\text{constant} + \mathbf{w} \quad (0.2 \text{ pts})$$

$$v_m = \frac{\mathbf{w}}{\mathbf{b}}$$

$$v_m = \frac{1}{\mathbf{w} \left\{ \frac{\mathbf{ne}}{2} \left[\left(1 + \frac{\mathbf{s}^2}{\mathbf{e}^2 \mathbf{w}^2} \right)^{1/2} + 1 \right] \right\}^{1/2}} \quad (0.4 \text{ pts})$$

$$v_m = \frac{1}{\left\{ \frac{\mathbf{ne}}{2} (1+1) \right\}^{1/2}} = \frac{1}{\sqrt{\mathbf{ne}}} \quad (0.4 \text{ pts})$$

2. The maximum depth of detection (skin depth, d) of an object in the ground is inversely proportional to the attenuation constant:

(0.5 pts)

(0.3 pts)

(0.2 pts)

$$d = \frac{1}{a} = \frac{1}{w \left\{ \frac{\mathbf{ne}}{2} \left[\left(1 + \frac{\mathbf{s}^2}{\mathbf{e}^2 \mathbf{w}^2} \right)^{1/2} - 1 \right] \right\}^{1/2}} = \frac{1}{w \left\{ \frac{\mathbf{ne}}{2} \left[\left(1 + \frac{1}{2} \frac{\mathbf{s}^2}{\mathbf{e}^2 \mathbf{w}^2} \right) - 1 \right] \right\}^{1/2}} = \frac{1}{w \left\{ \frac{\mathbf{ne}}{2} \cdot \frac{1}{2} \frac{\mathbf{s}^2}{\mathbf{e}^2 \mathbf{w}^2} \right\}^{1/2}}$$

$$d = \left(\frac{2}{\mathbf{s}} \right) \left(\frac{\mathbf{e}}{\mathbf{m}} \right)^{1/2}.$$

Numerically $d = \frac{(5.31\sqrt{\mathbf{e}_r})}{\mathbf{s}}$ m, where \mathbf{s} is in mS/m. (0.5 pts)

For a medium with conductivity of 1.0 mS/m and relative permittivity of 9, the skin depth

$$d = \frac{(5.31\sqrt{9})}{1.0} = 15.93 \text{ m} \quad (0.3 \text{ pts}) + (0.2 \text{ pts})$$

3. Lateral resolution:

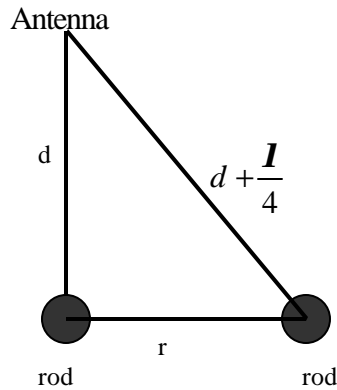

$$r^2 + d^2 = \left(d + \frac{I}{4}\right)^2$$

$$r = \left(\frac{Id}{2} + \frac{I^2}{16}\right)^{1/2}$$

(1.0 pts)

$r = 0.5 \text{ m}, d = 4 \text{ m}: \frac{1}{2} = \left(\frac{4I}{2} + \frac{I^2}{16}\right)^{1/2}, I^2 + 32I - 4 = 0$ (0.5 pts)

The wavelength is $\lambda = 0.125 \text{ m}$.

(0.3 pts) + (0.2 pts)

The propagation speed of the signal in medium is

$$v_m = \frac{1}{\sqrt{\mathbf{m}\mathbf{e}}} = \frac{1}{\sqrt{\mathbf{m}_b \mathbf{m}_r \mathbf{e}_o \mathbf{e}_r}} = \frac{1}{\sqrt{\mathbf{m}_b \mathbf{e}_o}} \frac{1}{\sqrt{\mathbf{m}_r \mathbf{e}_r}}$$

$$v_m = \frac{c}{\sqrt{\mathbf{m}_r \mathbf{e}_r}} = \frac{0.3}{\sqrt{\mathbf{e}_r}} \text{ m/ns}, \text{ where } c = \frac{1}{\sqrt{\mathbf{m}_b \mathbf{e}_o}} \text{ and } \mathbf{m}_r = 1$$

$$v_m = 0.1 \text{ m/ns} = 10^8 \text{ m/s} \quad (0.5 \text{ pts})$$

The minimum frequency need to distinguish the two rods as two separate objects is

$$f_{\min} = \frac{v}{I} \quad (0.5 \text{ pts})$$

$$f_{\min} = \frac{0.3}{0.125} \times 10^9 \text{ Hz} = 800 \text{ MHz} \quad (0.3 \text{ pts}) + (0.20 \text{ pts})$$

4. Path of EM waves for some positions on the ground surface

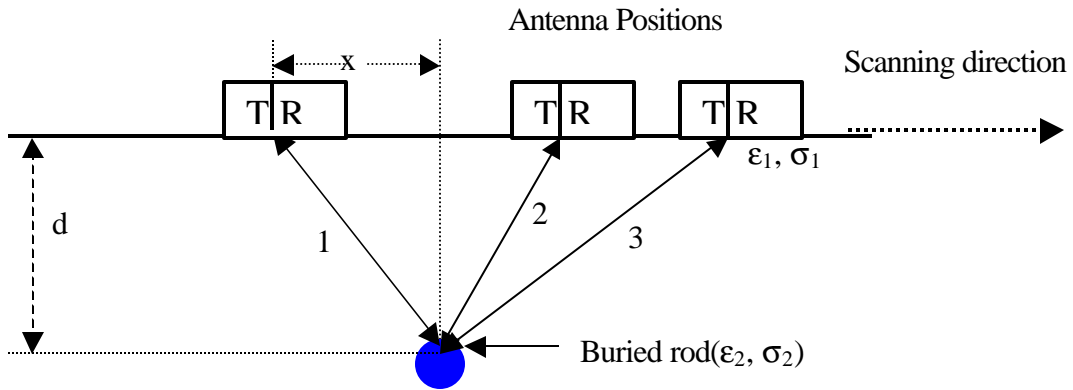

The traveltime as function of x is

$$\left(\frac{t}{2} v\right)^2 = d^2 + x^2, \quad (1.0 \text{ pts})$$

$$t(x) = \sqrt{\frac{4d^2 + 4x^2}{v}} \quad (1.0 \text{ pts})$$

$$t(x) = \frac{2\sqrt{\epsilon_{1r}}}{0.3} \sqrt{d^2 + x^2}$$

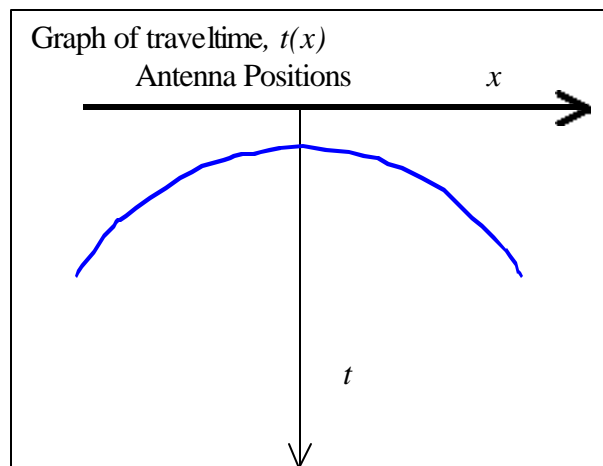

For $x = 0$ (1.0 pts)

$$100 = 2 \times (3/0.3) d$$

$d = 5 \text{ m}$ (0.5 pts)



THEORETICAL COMPETITION
Tuesday, July 23rd, 2002

Solution II: Sensing Electrical Signals

1. When a point current source I_s is in infinite isotropic medium, the current density vector at a distance r from the point is

$$\vec{j} = \frac{I_s}{4\pi r^3} \vec{r}$$

[+1.5 pts] (without vector notation, -0.5 pts)

- 2.

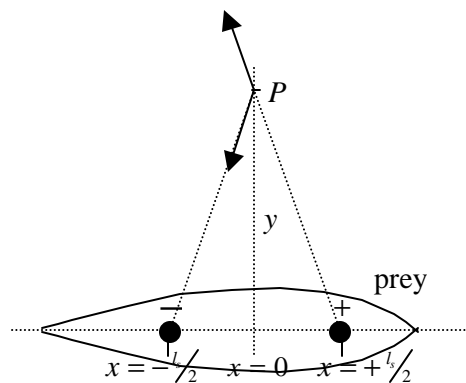

Assuming that the resistivities of the prey body and that of the surrounding seawater are the same, implying the elimination of the boundary surrounding the prey, the two spheres seem to be in infinite isotropic medium with the resistivity of r . When a small sphere produces current at a rate I_s , the current flux density at a distance r from the sphere's center is also

$$\vec{j} = \frac{I_s}{4\pi r^3} \vec{r}$$

The seawater resistivity is r , therefore the field strength at r is

$$\vec{E}(\vec{r}) = r\vec{j} = \frac{rI_s}{4\pi r^3} \vec{r} \quad [+0.2 \text{ pts}]$$

In the model, we have two small spheres. One is at positive voltage relative to the other therefore current I_s flows from the positively charged sphere to the negatively charged sphere. They are separated by l_s . The field strength at P(0,y) is:

$$\vec{E}_p = \vec{E}_+ + \vec{E}_- \quad [+0.8 \text{ pts}]$$

$$= \frac{rI_s}{4p} \left[\frac{1}{\left(\left(\frac{l_s}{2}\right)^2 + y^2\right)^{\frac{3}{2}}} \left(-\frac{l_s}{2}i + yj\right) + \frac{1}{\left(\left(\frac{l_s}{2}\right)^2 + y^2\right)^{\frac{3}{2}}} \left(-\frac{l_s}{2}i - yj\right) \right]$$

$$= \frac{rI_s}{4p} \left[\frac{l_s(-i)}{\left(\left(\frac{l_s}{2}\right)^2 + y^2\right)^{\frac{3}{2}}} \right]$$

$$\vec{E}_p \approx \frac{rI_s l_s}{4py^3} (-i) \quad \text{for } l_s \ll y \quad [+1.0 \text{ pts}]$$

3. The field strength along the axis between the two source spheres is:

$$\vec{E}(x) = \frac{rI_s}{4p} \left(\frac{1}{\left(x - \frac{l_s}{2}\right)^2} + \frac{1}{\left(x + \frac{l_s}{2}\right)^2} \right) (-i) \quad [+0.5 \text{ pts}]$$

The voltage difference to produce the given current I_s is

$$V_s = \Delta V = V_+ - V_- = - \int_{\left(-\frac{l_s}{2} + r_s\right)}^{\left(\frac{l_s}{2} - r_s\right)} \vec{E}(x) d\vec{x} = - \frac{rI_s}{4p} \int \left(\frac{1}{\left(x - \frac{l_s}{2}\right)^2} + \frac{1}{\left(x + \frac{l_s}{2}\right)^2} \right) (-i)(dx) \quad [+0.5 \text{ pts}]$$

$$= \frac{rI_s}{4p} \left[\frac{1}{-2+1} \left(\frac{1}{\left(\frac{l_s}{2} - r_s - \frac{l_s}{2}\right)} - \frac{1}{\left(-\frac{l_s}{2} + r_s - \frac{l_s}{2}\right)} \right) + \frac{1}{-2+1} \left(\frac{1}{\left(\frac{l_s}{2} - r_s + \frac{l_s}{2}\right)} - \frac{1}{\left(-\frac{l_s}{2} + r_s + \frac{l_s}{2}\right)} \right) \right]$$

$$= \frac{rI_s}{4p} \left(\frac{2}{r_s} - \frac{2}{l_s - r_s} \right) = \frac{2rI_s}{4p} \left(\frac{l_s - r_s - r_s}{(l_s - r_s)r_s} \right) = \frac{rI_s}{2pr_s} \left(\frac{l_s - 2r_s}{l_s - r_s} \right)$$

$$V_s = \Delta V \approx \frac{rI_s}{2pr_s} \quad \text{for } l_s \gg r_s. \quad [+0.5 \text{ pts}]$$

The resistance between the two source spheres is:

$$R_s = \frac{V_s}{I_s} = \frac{r}{2pr_s}$$

[+0.5 pts]

The power produced by the source is:

$$P = I_s V_s = \frac{r I_s^2}{2pr_s}$$

[+0.5 pts]

4.

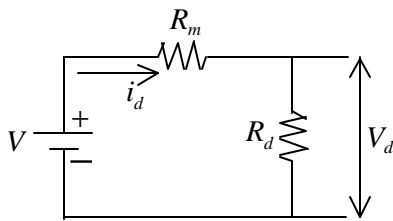

V is the voltage difference between the detector's spheres due to the electric field induced by the prey, R_m is the inner resistance due to the surrounding sea water. V_d and R_d are respectively the voltage difference between the detecting spheres and the resistance of the detecting element within the predator and i_d is the current flowing in the closed circuit.

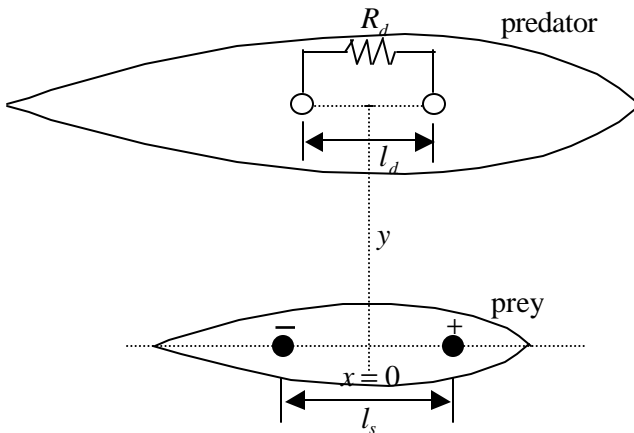

Analog to the resistance between the two source spheres, the resistance of the medium with resistivity r between the detector spheres, each having a radius of r_d is:

$$R_m = \frac{r}{2pr_d}$$

[+0.5 pts]

Since l_d is much smaller than y , the electric field strength between the detector spheres can be assumed to be constant, that is:

$$E = \frac{r I_s l_s}{4py^3} \quad [+0.2 \text{ pts}]$$

Therefore, the voltage difference present in the medium between the detector spheres is:

$$V = E l_d = \frac{r I_s l_s l_d}{4py^3} \quad [+0.3 \text{ pts}]$$

The voltage difference across the detector spheres is:

$$V_d = V \frac{R_d}{R_d + R_m} = \frac{\mathbf{r} I_s l_s l_d}{4\mathbf{p}y^3} \frac{R_d}{R_d + \frac{\mathbf{r}}{2\mathbf{p}r_d}}$$

[+0.5 pts]

The power transferred from the source to the detector is:

$$P_d = i_d V_d = \frac{V}{R_d + R_m} V_d = \left(\frac{\mathbf{r} I_s l_s l_d}{4\mathbf{p}y^3} \right)^2 \frac{R_d}{\left(R_d + \frac{\mathbf{r}}{2\mathbf{p}r_d} \right)^2}$$

[+0.5 pts]

5. P_d is maximum when

$$R_l = \frac{R_d}{\left(R_d + \frac{\mathbf{r}}{2\mathbf{p}r_d} \right)^2} = \frac{R_d}{(R_d + R_m)^2} \text{ is maximum} \quad [+0.5 \text{ pts}]$$

Therefore,

$$\frac{dR_l}{dR_d} = \frac{1(R_d + R_m)^2 - R_d 2(R_d + R_m)}{(R_d + R_m)^4} = 0 \quad [+0.5 \text{ pts}]$$

$$(R_d + R_m) - 2R_d = 0$$

$$R_d^{optimum} = R_m = \frac{\mathbf{r}}{2\mathbf{p}r_d} \quad [+0.5 \text{ pts}]$$

The maximum power is:

$$P_d^{maximum} = \left(\frac{\mathbf{r} I_s l_s l_d}{4\mathbf{p}y^3} \right)^2 \frac{\mathbf{p}r_d}{2\mathbf{r}} = \frac{\mathbf{r} (I_s l_s l_d)^2 r_d}{32\mathbf{p}y^6}$$

[+0.5 pts]

SOLUTION T3 :. A Heavy Vehicle Moving on An Inclined Road

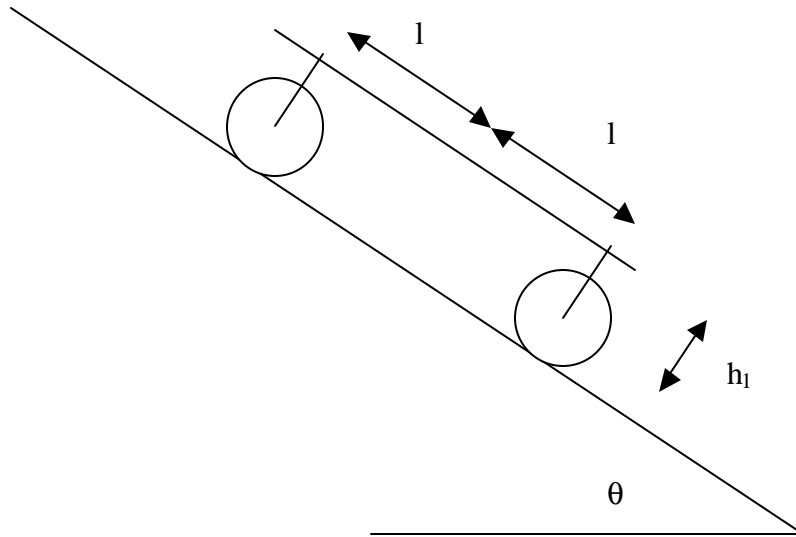

To simplify the model we use the above figure with $h_1 = h + 0.5 t$
 $R_o = R$

1. Calculation of the moment inertia of the cylinder

$$R_i = 0.8 R_o$$

$$\text{Mass of cylinder part : } m_{\text{cylinder}} = 0.8 M$$

$$\text{Mass of each rod : } m_{\text{rod}} = 0.025 M$$

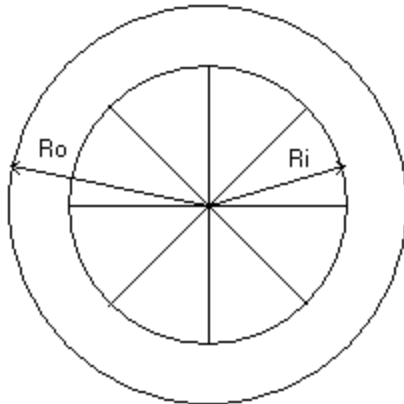

$$I = \oint_{\text{wholepart}} r^2 dm = \oint_{\text{cyl.shell}} r^2 dm + \oint_{\text{rod1}} r^2 dm + \dots + \oint_{\text{rodn}} r^2 dm \quad 0.4 \text{ pts}$$

$$\begin{aligned} \oint_{\text{cyl.shell}} r^2 dm &= 2\psi \int_{R_i}^{R_o} r^3 dr = 0.5\psi (R_o^4 - R_i^4) = 0.5m_{\text{cylinder}} (R_o^2 + R_i^2) \\ &= 0.5(0.8M)R^2(1 + 0.64) = 0.656MR^2 \end{aligned} \quad 0.5 \text{ pts}$$

$$\oint_{\text{rod}} r^2 dm = \mathbf{I} \int_0^{R_{in}} r^2 dr = \frac{1}{3} \mathbf{I} R_{in}^3 = \frac{1}{3} m_{\text{rod}} R_{in}^2 = \frac{1}{3} 0.025M (0.64R^2) = 0.00533MR^2 \quad 0.5 \text{ pts}$$

The moment inertia of each wheel becomes

$$I = 0.656MR^2 + 8 \times 0.00533MR^2 = 0.7MR^2 \quad 0.1 \text{ pts}$$

2. Force diagram and balance equations:

To simplify the analysis we divide the system into three parts: frame (part1) which mainly can be treated as flat homogeneous plate, rear cylinders (two cylinders are treated collectively as part 2 of the system), and front cylinders (two front cylinders are treated collectively as part 3 of the system).

Part 1 : Frame

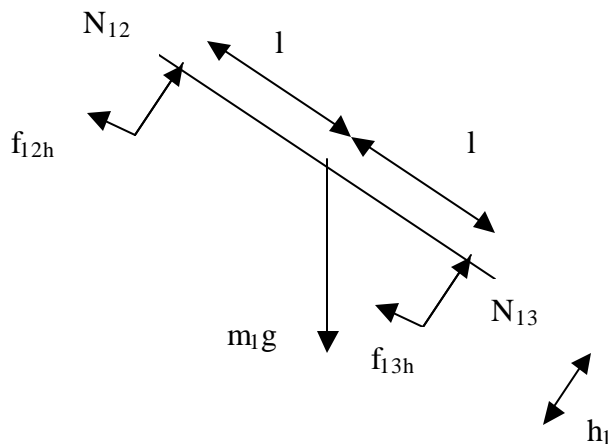

0.4 pts

The balance equation related to the forces work to this parts are:

Required conditions:

Balance of force in the horizontal axis

$$m_1 g \sin \mathbf{q} - f_{12h} - f_{13h} = m_1 a \quad (1) \quad 0.2 \text{ pts}$$

Balance of force in the vertical axis

$$m_1 g \cos \mathbf{q} = N_{12} + N_{13} \quad (2) \quad 0.2 \text{ pts}$$

Then torsi on against O is zero, so that

$$N_{12}l - N_{13}l + f_{12h}h_1 + f_{13h}h_1 = 0 \quad (3) \quad 0.2 \text{ pts}$$

Part two : Rear cylinder

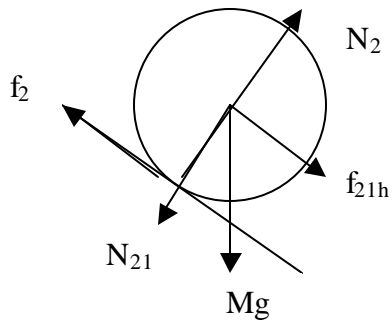

0.25 pts

From balance condition in rear wheel :

$$f_{21h} - f_2 + Mg \sin \mathbf{q} = Ma \quad (4) \quad 0.15 \text{ pts}$$

$$N_2 - N_{21} - Mg \cos \mathbf{q} = 0 \quad (5) \quad 0.15 \text{ pts}$$

For pure rolling:

$$f_2 R = I \mathbf{a}_2 = I \frac{a_2}{R}$$

$$\text{or } f_2 = \frac{I}{R^2} a \quad (6)$$

For rolling with sliding:

$$F_2 = \mu_k N_2 \quad (7)$$

0.2 pts

Part Three : Front Cylinder:

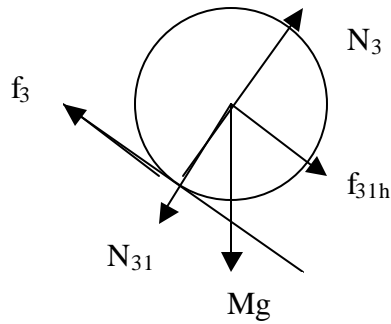

0.25 pts

From balance condition in the front wheel 1 :

$$f_{31h} - f_3 + Mg \sin \mathbf{q} = Ma \quad (8) \quad 0.15 \text{ pts}$$

$$N_3 - N_{31} - Mg \cos \mathbf{q} = 0 \quad (9) \quad 0.15 \text{ pts}$$

For pure rolling:

$$f_3 R = I \mathbf{a}_3 = I \frac{a_3}{R}$$

$$\text{or } f_3 = \frac{I}{R^2} a \quad (10)$$

For rolling with sliding:

$$F_3 = \mu_k N_3 \quad (11)$$

0.2 pts

3. From equation (2), (5) and (9) we get

$$\begin{aligned} m_1 g \cos \theta &= N_2 - m_2 g \cos \theta + N_3 - m_3 g \cos \theta \\ N_2 + N_3 &= (m_1 + m_2 + m_3) g \cos \theta = 7Mg \cos \theta \end{aligned} \quad (12)$$

And from equation (3), (5) and (8) we get

$$(N_3 - Mg \cos \theta) l - (N_2 - Mg \cos \theta) l = h_1 (f_2 + Ma - Mg \sin \theta + f_3 + Ma - Mg \sin \theta)$$

$$(N_3 - N_2) = h_1 (f_2 + 2Ma - 2Mg \sin \theta + f_3) / l$$

Equations 12 and 13 are given **0.25 pts**

CASE ALL CYLINDER IN PURE ROLLING

From equation (4) and (6) we get

$$f_{21h} = (I/R^2)a + Ma - Mg \sin\theta \quad (14) \quad 0.2 \text{ pts}$$

From equation (8) and (10) we get

$$f_{31h} = (I/R^2)a + Ma - Mg \sin\theta \quad (15) \quad 0.2 \text{ pts}$$

Then from eq. (1) , (14) and (15) we get

$$5Mg \sin\theta - \{(I/R^2)a + Ma - Mg \sin\theta\} - \{(I/R^2)a + Ma - Mg \sin\theta\} = m_1 a$$

$$7 Mg \sin\theta = (2I/R^2 + 7M)a$$

$$a = \frac{7Mg \sin \mathbf{q}}{7M + 2\frac{I}{R^2}} = \frac{7Mg \sin \mathbf{q}}{7M + 2\frac{0.7MR^2}{R^2}} = 0.833g \sin \mathbf{q} \quad (16) \quad 0.35 \text{ pts}$$

$$\begin{aligned} N_3 &= \frac{7M}{2} g \cos \mathbf{q} + \frac{h_1}{l} [(M + \frac{I}{R^2}) \times 0.833g \sin \mathbf{q} - Mg \sin \mathbf{q}] \\ &= 3.5Mg \cos \mathbf{q} + \frac{h_1}{l} [(M + 0.7M) \times 0.833g \sin \mathbf{q} - Mg \sin \mathbf{q}] \\ &= 3.5 Mg \cos \mathbf{q} + 0.41 \frac{h_1}{l} Mg \sin \mathbf{q} \end{aligned}$$

$$\begin{aligned} N_2 &= \frac{7M}{2} g \cos \mathbf{q} - \frac{h_1}{l} [(\frac{I}{R^2} + M) \times 0.833g \sin \mathbf{q} - Mg \sin \mathbf{q}] \\ &= 3.5g \cos \mathbf{q} - \frac{h_1}{l} [(0.7M + M) \frac{7Mg \sin \mathbf{q}}{0.7M + 7M} - 2Mg \sin \mathbf{q}] \\ &= 3.5g \cos \mathbf{q} - 0.41 \frac{h_1}{l} Mg \sin \mathbf{q} \end{aligned}$$

0.2 pts

The Conditions for pure rolling:

$$f_2 \leq \mathbf{m}_s N_2 \quad \text{and} \quad f_3 \leq \mathbf{m}_s N_3$$

$$\frac{I_2}{R_2^2} a \leq \mathbf{m}_s N_2 \quad \text{and} \quad \frac{I_3}{R_3^2} a \leq \mathbf{m}_s N_3$$

0.2 pts

The left equation becomes

$$0.7M \times 0.833g \sin \mathbf{q} \leq \mathbf{m}_s (3.5Mg \cos \mathbf{q} - 0.41 \frac{h_1}{l} Mg \sin \mathbf{q})$$

$$\tan \mathbf{q} \leq \frac{3.5\mathbf{m}_s}{0.5831 + 0.41\mathbf{m}_s \frac{h_1}{l}}$$

While the right equation becomes

$$0.7m \times 0.833g \sin \mathbf{q} \leq \mathbf{m}_s (3.5mg \cos \mathbf{q} + 0.41 \frac{h_1}{l} mg \sin \mathbf{q})$$

$$\tan \mathbf{q} \leq \frac{3.5\mathbf{m}_s}{0.5831 - 0.41\mathbf{m}_s \frac{h_1}{l}}$$

(17) 0.1 pts

CASE ALL CYLINDER SLIDING

$$\text{From eq. (4)} \quad f_{21h} = Ma + u_k N_2 - Mg \sin \theta \quad (18) \quad 0.15 \text{ pts}$$

$$\text{From eq. (8)} \quad f_{31h} = Ma + u_k N_3 - Mg \sin \theta \quad (19) \quad 0.15 \text{ pts}$$

From eq. (18) and 19 :

$$5Mg \sin \theta - (Ma + u_k N_2 - Mg \sin \theta) - (Ma + u_k N_3 - Mg \sin \theta) = m_1 a$$

$$a = \frac{7Mg \sin \mathbf{q} - \mathbf{m}_k N_2 - \mathbf{m}_k N_3}{7M} = g \sin \mathbf{q} - \frac{\mathbf{m}_k (N_2 + N_3)}{7M} \quad (20) \quad 0.2 \text{ pts}$$

$$N_3 + N_2 = 7Mg \cos \mathbf{q}$$

From the above two equations we get :

$$a = g \sin \mathbf{q} - \mathbf{m}_k g \cos \mathbf{q} \quad 0.25 \text{ pts}$$

The Conditions for complete sliding: are the opposite of that of pure rolling

$$\begin{aligned} f_2 > \mathbf{m}_s N'_2 & \quad \text{and} \quad f_3 > \mathbf{m}_s N'_3 \\ \frac{I_2}{R_2^2} a > \mathbf{m}_s N'_2 & \quad \text{and} \quad \frac{I_3}{R_3^2} a > \mathbf{m}_s N'_3 \end{aligned} \quad (21) \quad 0.2 \text{ pts}$$

Where N_2' and N_3' is calculated in case all cylinder in pure rolling. 0.1 pts

Finally we get

$$\tan \mathbf{q} > \frac{3.5\mathbf{m}_s}{0.5831 + 0.41\mathbf{m}_s \frac{h_1}{l}} \quad \text{and} \quad \tan \mathbf{q} > \frac{3.5\mathbf{m}_s}{0.5831 - 0.41\mathbf{m}_s \frac{h_1}{l}} \quad 0.2 \text{ pts}$$

The left inequality finally become decisive.

CASE ONE CYLINDER IN PURE ROLLING AND ANOTHER IN SLIDING CONDITION

{ For example R_3 (front cylinders) pure rolling while R_2 (Rear cylinders) sliding }

From equation (4) we get

$$F_{21h} = m_2 a + \mu_k N_2 - m_2 g \sin \theta \quad (22) \quad 0.15 \text{ pts}$$

From equation (5) we get

$$f_{31h} = m_3 a + (I/R^2) a - m_3 g \sin \theta \quad (23) \quad 0.15 \text{ pts}$$

Then from eq. (1), (22) and (23) we get

$$m_1 g \sin \theta - \{ m_2 a + \mu_k N_2 - m_2 g \sin \theta \} - \{ m_3 a + (I/R^2) a - m_3 g \sin \theta \} = m_1 a$$

$$m_1 g \sin \theta + m_2 g \sin \theta + m_3 g \sin \theta - \mu_k N_2 = (I/R^2 + m_3) a + m_2 a + m_1 a$$

$$5Mg \sin \theta + Mg \sin \theta + Mg \sin \theta - \mu_k N_2 = (0.7M + M) a + Ma + 5Ma$$

$$a = \frac{7Mg \sin \theta - \mu_k N_2}{7.7M} = 0.9091g \sin \theta - \frac{\mu_k N_2}{7.7M} \quad (24) \quad 0.2 \text{ pts}$$

$$N_3 - N_2 = \frac{h_1}{l} (\mu_k N_2 + \frac{I}{R^2} a + 2Ma - 2Mg \sin \theta)$$

$$N_3 - N_2 = \frac{h_1}{l} (\mu_k N_2 + 2.7M \times 0.9091g \sin \theta - 2.7 \mu_k N_2 / 7.7 - 2Mg \sin \theta)$$

$$N_3 - N_2 (1 + 0.65 \mu_k \frac{h_1}{l}) = 0.4546Mg \sin \theta$$

$$N_3 + N_2 = 7Mg \cos \theta$$

Therefore we get

$$N_2 = \frac{7Mg \cos \theta - 0.4546Mg \sin \theta}{2 + 0.65 \mu_k \frac{h_1}{l}} \quad (25) \quad 0.3 \text{ pts}$$

$$N_3 = 7Mg \cos \theta - \frac{7Mg \cos \theta - 0.4546Mg \sin \theta}{2 + 0.65 \mu_k \frac{h_1}{l}}$$

Then we can substitute the results above into equation (16) to get the following result

$$a = 0.9091g \sin \theta - \frac{\mu_k N_2}{7.7M} = 0.9091g \sin \theta - \frac{\mu_k}{7.7} \frac{7g \cos \theta - 0.4546g \sin \theta}{2 + 0.65 \mu_k \frac{h_1}{l}} \quad (26)$$

0.2 pts

The Conditions for this partial sliding is:

$$\begin{aligned} f_2 \leq \mu_3 N'_2 \quad \text{and} \quad f_3 > \mu_3 N'_3 \\ \frac{I}{R^2} a \leq \mu_3 N'_2 \quad \text{and} \quad \frac{I}{R^2} a > \mu_3 N'_3 \end{aligned} \quad (27) \quad 0.25 \text{ pts}$$

where N'_2 and N'_3 are normal forces for pure rolling condition

4. Assumed that after rolling d meter all cylinder start to sliding until reaching the end of incline road (total distant is s meter). Assumed that t_1 meter is reached in t_1 second.

$$v_{t1} = v_o + at_1 = 0 + a_1 t_1 = a_1 t_1$$

$$d = v_o t_1 + \frac{1}{2} a_1 t_1^2 = \frac{1}{2} a_1 t_1^2$$

$$t_1 = \sqrt{\frac{2d}{a_1}}$$

0.5 pts

$$v_{t1} = a_1 \sqrt{\frac{2d}{a_1}} = \sqrt{2da_1} = \sqrt{2d \cdot 0.833g \sin \mathbf{q}} = \sqrt{1.666dg \sin \mathbf{q}} \quad (28)$$

The angular velocity after rolling d meters is same for front and rear cylinders:

$$\mathbf{w}_{t1} = \frac{v_{t1}}{R} = \frac{1}{R} \sqrt{1.666dg \sin \mathbf{q}} \quad (29)$$

0.5 pts

Then the vehicle sliding until the end of declining road. Assumed that the time needed by vehicle to move from d position to the end of the declining road is t_2 second.

$$v_{t2} = v_{t1} + a_2 t_2 = \sqrt{1.666dg \sin \mathbf{q}} + a_2 t_2$$

$$s - d = v_{t1} t_2 + \frac{1}{2} a_2 t_2^2$$

$$t_2 = \frac{-v_{t1} + \sqrt{v_{t1}^2 + 2a_2(s-d)}}{a_2} \quad (30) \quad 0.4 \text{ pts}$$

$$v_{t2} = \sqrt{1.666dg \sin \mathbf{q}} - v_{t1} + \sqrt{v_{t1}^2 + 2a_2(s-d)}$$

Inserting v_{t1} and a_2 from the previous results we get the final results.

For the angular velocity, while sliding they receive torsion:

$$t = m_k NR$$

$$\mathbf{a} = \frac{t}{I} = \frac{m_k NR}{I} \quad (31)$$

$$w_{i2} = w_{i1} + \mathbf{a}t_2 = \frac{1}{R} \sqrt{1.666 dg \sin \mathbf{q}} + \frac{m_k NR}{I} \frac{-v_{i1} + \sqrt{v_{i1}^2 + 2a_2(s-d)}}{a_2}$$

0.6 pts

SOLUTION EXPERIMENT I

PART A

1. [Total 0.5 pts]

The experimental method chosen for the calibration of the arbitrary scale is a simple pendulum method [0.3 pts]

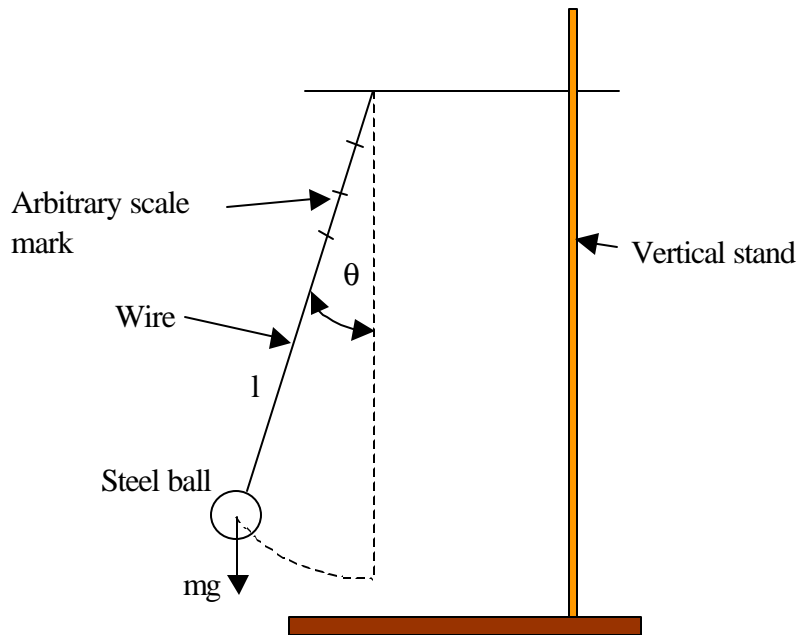

Figure 1. Sketch of the experimental set up [0.2 pts]

2. [Total 1.5 pts]

The expression relating the measurable quantities: [0.5 pts]

$$T_{osc} = 2\mathbf{p}\sqrt{\frac{l}{g}}; T_{osc}^2 = 4\mathbf{p}^2 \frac{l}{g}$$

Approximations :

$$\sin \mathbf{q} \approx \mathbf{q} \quad [0.5 \text{ pts}]$$

mathematical pendulum (mass of the wire \ll mass of the steel ball,
the radius of the steel ball \ll length of the wire [0.5 pts]

flexibility of the wire, air friction, etc [0.1 pts, only when one of the two
major points above is not given]

3. **[Total 1.0 pts]** Data sample from simple pendulum experiment
 # of cycle ≥ 20 [0.2 pts.] , difference in $T \geq 0.01$ s [0.4 pts], # of data ≥ 4 [0.4 pts]

No.	t(s) for 50 cycles	Period, T (s)	Scale marked on the wire (arbitrary scale)
1	91.47	1.83	200
2	89.09	1.78	150
3	86.45	1.73	100
4	83.8	1.68	50

4. **[Total 0.5 pts]**

No.	Period, T (s)	Scale marked on the wire (arbitrary scale)	T^2 (s ²)
1	1.83	200	3.35
2	1.78	150	3.17
3	1.73	100	2.99
4	1.68	50	2.81

The plot of T^2 vs scale marked on the wire:

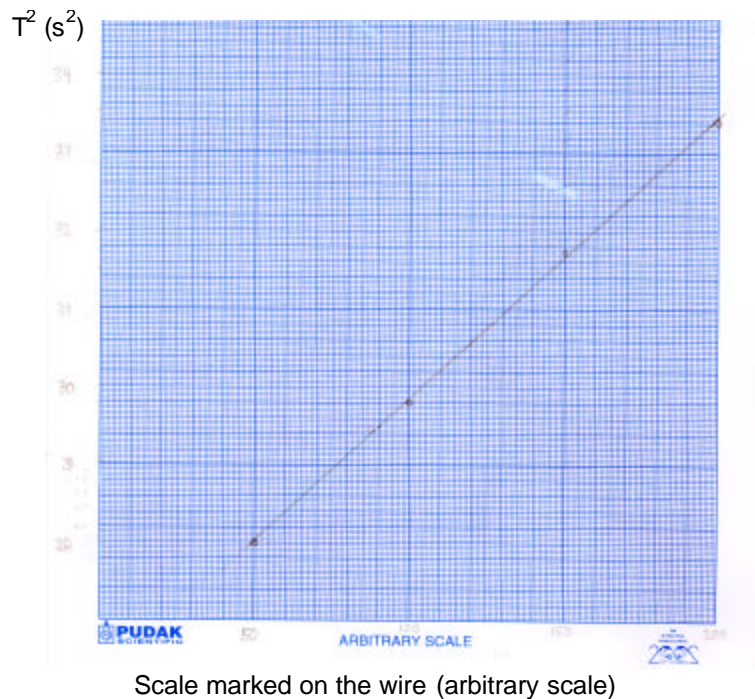

5. Determination of the smallest unit of the arbitrary scale in term of mm **[Total 1.5 pts]**

$$T_{osc1}^2 = \frac{4p^2}{g} L_1, \quad T_{osc2}^2 = \frac{4p^2}{g} L_2$$

$$(T_{osc1}^2 - T_{osc2}^2) = \frac{4p^2}{g} L_1 - L_2 = \frac{4p^2}{g} \Delta L$$

$$\Delta L = \frac{g}{4p^2} (T_{osc1}^2 - T_{osc2}^2) \text{ or other equivalent expression} \quad [0.5 \text{ pts}]$$

No.		Calculated ΔL (m)	ΔL in arbitrary scale	Values of smallest unit of arbitrary scale (mm)
1.	$T_1^2 - T_2^2 = 0.171893 \text{ s}^2$	0.042626	50	0.85
2.	$T_1^2 - T_3^2 = 0.357263 \text{ s}^2$	0.088595	100	0.89
3.	$T_1^2 - T_4^2 = 0.537728 \text{ s}^2$	0.133347	150	0.89
4.	$T_2^2 - T_3^2 = 0.18537 \text{ s}^2$	0.045968	50	0.92
5.	$T_2^2 - T_4^2 = 0.365835 \text{ s}^2$	0.09072	100	0.91
6.	$T_3^2 - T_4^2 = 0.180465 \text{ s}^2$	0.044752	50	0.90

The average value of smallest unit of arbitrary scale, $\bar{l} = 0.89 \text{ mm}$ [0.5 pts]

The estimated error induced by the measurement: [0.5 pts]

No.	Values of smallest unit of arbitrary scale (mm)	$(l - \bar{l})$	$(l - \bar{l})^2$
1.	0.85	-0.04	0.0016
2.	0.89	0	0
3.	0.89	0	0
4.	0.92	0.03	0.0009
5.	0.91	0.02	0.0004
6.	0.90	0.01	0.0001

And the standard deviation is:

$$\Delta l = \sqrt{\frac{\sum_{i=1}^6 (l - \bar{l})^2}{N - 1}} = \sqrt{\frac{0.003}{5}} = 0.02 \text{ mm}$$

other legitimate methods may be used

PART B

1. The experimental set up: [Total 1.0 pts]

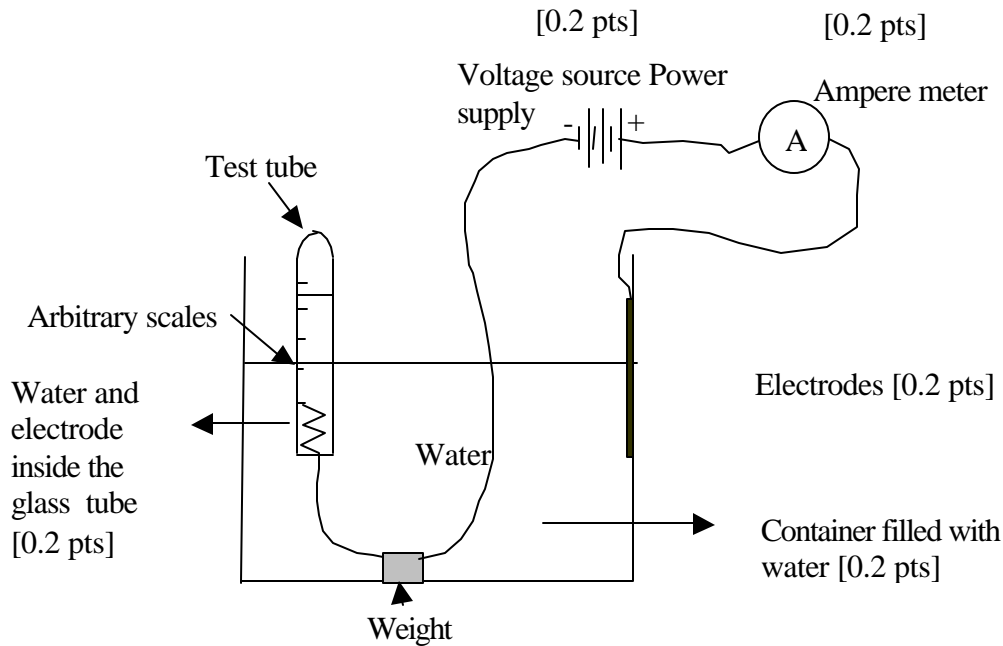

2. Derivation of equation relating the quantities time t , current I , and water level difference Δh : [Total 1.5 pts]

$$I = \frac{\Delta Q}{\Delta t}$$

From the reaction: $2 \text{H}^+ + 2 \text{e} \longrightarrow \text{H}_2$, the number of molecules produced in the process (ΔN) requires the transfer of electric charge is $\Delta Q = 2e \Delta N$: [0.2 pts]

$$I = \frac{\Delta N 2e}{\Delta t} \quad [0.5 \text{ pts}]$$

$$P \Delta V = \Delta N k_B T \quad [0.5 \text{ pts}]$$

$$= \frac{I \Delta t}{2e} k_B T$$

$$P \Delta h(\rho^2) = \frac{I \Delta t}{2} \frac{k_B}{e} T \quad [0.2 \text{ pts}]$$

$$I \Delta t = \frac{e}{k_B} \frac{2P(\rho^2)}{T} \Delta h \quad [0.1 \text{ pts}]$$

3. The experimental data: [**Total 1.0 pts**]

No.	Δh (arbitrary scale)	I (mA)	Δt (s)
1	12	4.00	1560.41
2	16	4.00	2280.61
3	20	4.00	2940.00
4	24	4.00	3600.13

- The circumference ϕ , of the test tube = 46 arbitrary scale [0.3 pts]
- The chosen values for Δh (≥ 4 scale unit) for acceptable error due to uncertainty of the water level reading and for I (≤ 4 mA) for acceptable disturbance [0.3 pts]
- # of data ≥ 4 [0.4 pts]

The surrounding condition (T, P) in which the experimental data given above taken:

$$T = 300 \text{ K}$$

$$P = 1.00 \cdot 10^5 \text{ Pa}$$

4. Determination the value of e/k_B [**Total 1.5 pts**]

No.	Δh (arbitrary scale)	Δh (mm)	I (mA)	Δt (s)	$I \Delta t$ (C)
1	12	10.68	4.00	1560.41	6241.64
2	16	14.24	4.00	2280.61	9120.48
3	20	17.80	4.00	2940.00	11760.00
4	24	21.36	4.00	3600.13	14400.52

Plot of $I \Delta t$ vs Δh from the data listed above

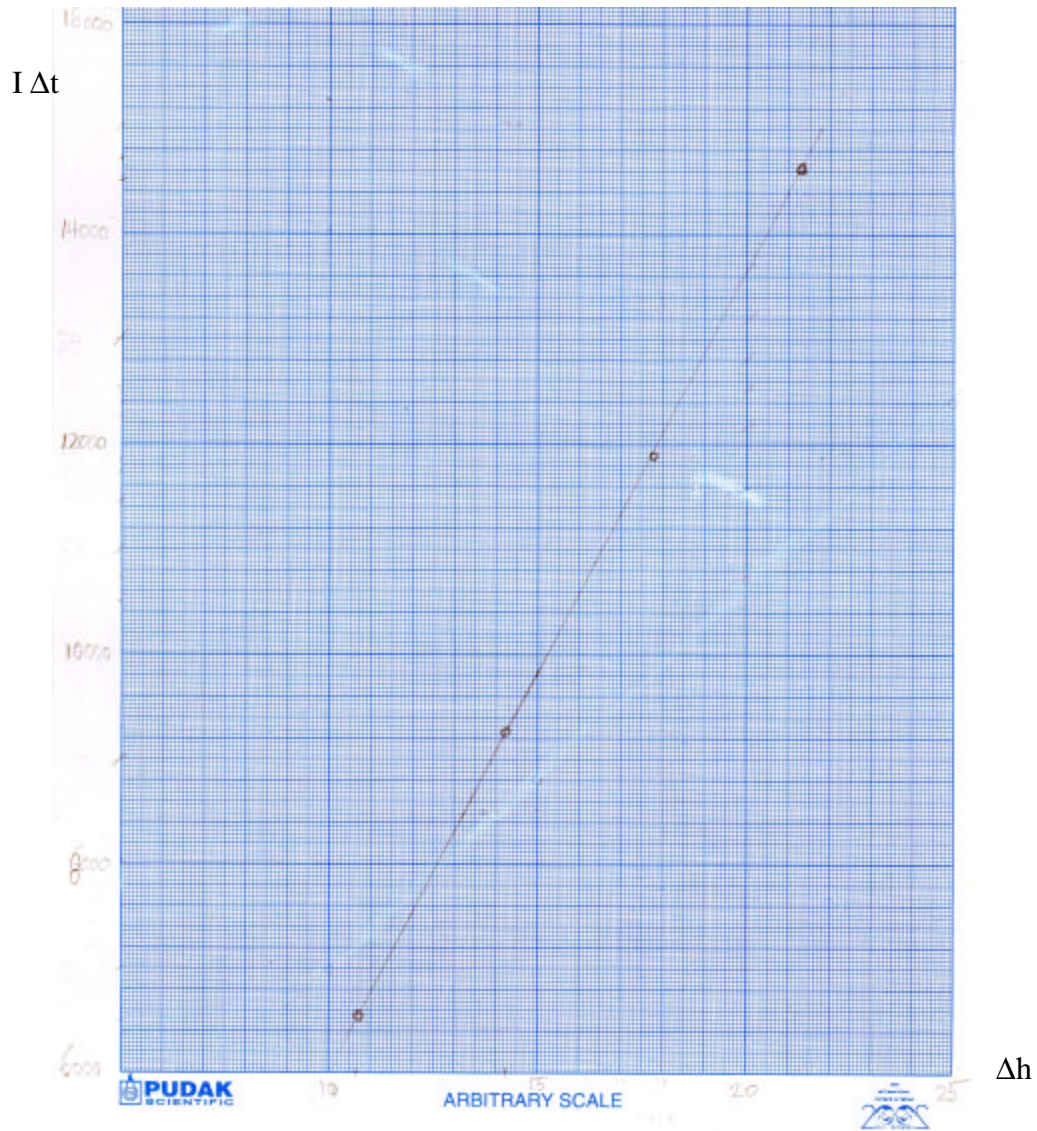

The slope obtained from the plot is 763.94;

$$\frac{e}{k_B} = \frac{763.94 \times 300 \times p}{2 \times 10^5 \times (23 \times 0.89 \times 10^{-3} \times 0.82)^2} = 1.28 \times 10^4 \text{ Coulomb K/J}$$

[1.0 pts]

Alternatively [the same credit points]

No.	Δh (mm)	$I \Delta t$ (C)	Slope	e/k_b
1	10.68	6241.64	584.4232	9774.74
2	14.24	9120.48	640.4831	10712.37
3	17.80	11760.00	660.6742	11050.07
4	21.36	14400.52	674.1816	11275.99

Average of $e/k_b = 1.07 \times 10^4$ Coulomb K/J
[1.0 pts]

No.	e/k_b	difference	Square difference
1	9774.74	-928.55	862205.5
2	10712.37	9.077117	82.39405
3	11050.07	346.7808	120256.9
4	11275.99	572.6996	327984.9

Estimated error

[0.5 pts]

The standard deviation obtained is 0.66×10^3 Coulomb K/J,
Other legitimate measures of estimated error may be also used

SOLUTION OF EXPERIMENT PROBLEM 2

1. The optical components are **[total 1.5 pts]**:

no.1 Diffraction grating [0.5 pts]

no.2 Diffraction grating [0.5 pts]

no.3 Plan-parallel plate [0.5 pts]

2. Cross section of the box **[total 1.5 pts]**:

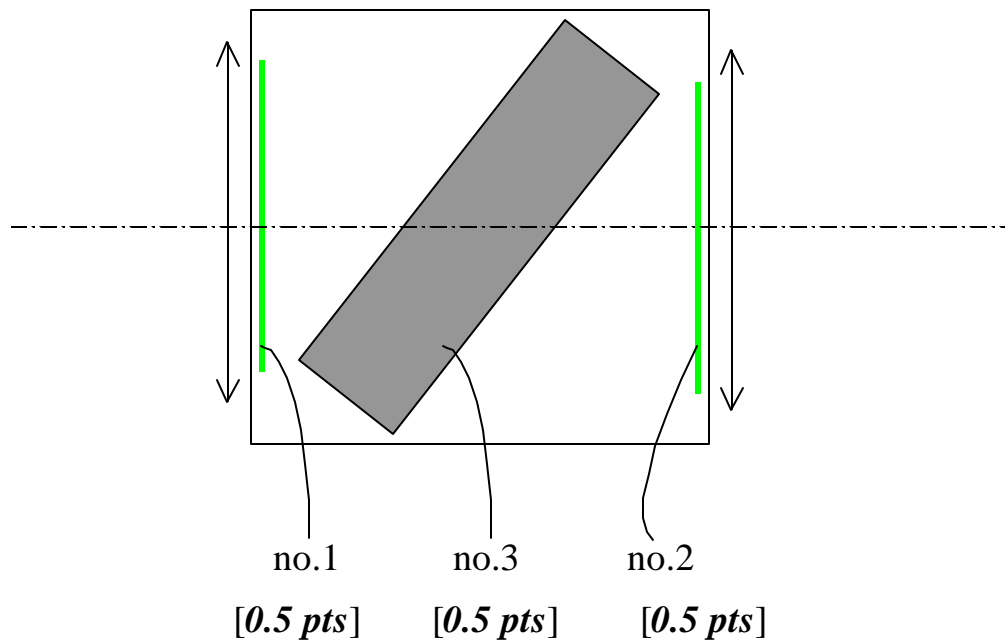

3. Additional information [total 1.0 pts]:

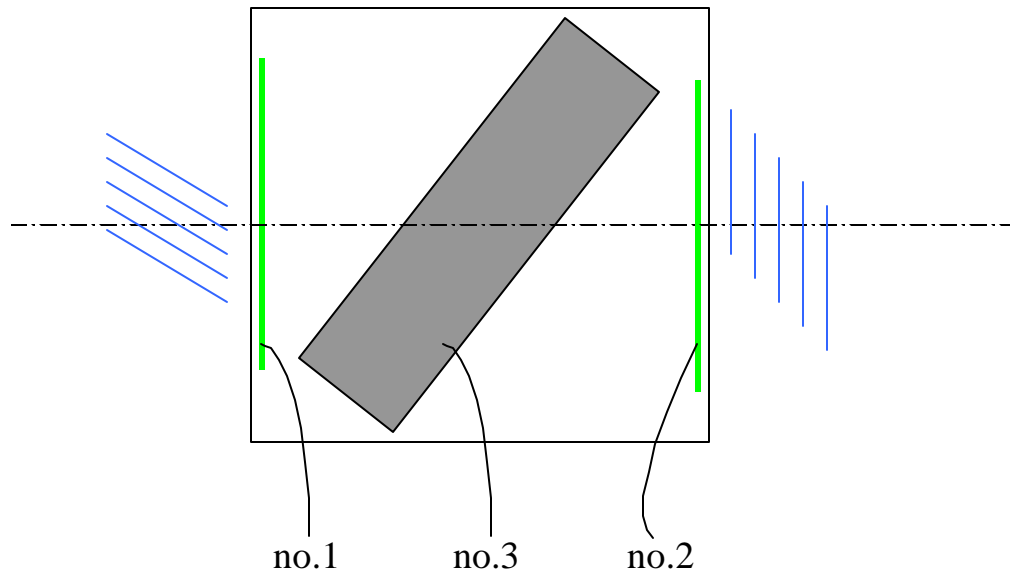

Distance of the grating (no.1)
to the left wall is practically zero
[0.2 pts]

Distance of the grating (no.2)
to the right wall is practically zero
[0.2 pts]

Lines of grating no.1 is at
right angle to the slit
[0.3 pts]

Lines of grating no. 2
is parallel to the slit
[0.3 pts]

4. Diffraction grating [total 2.0 pts]:

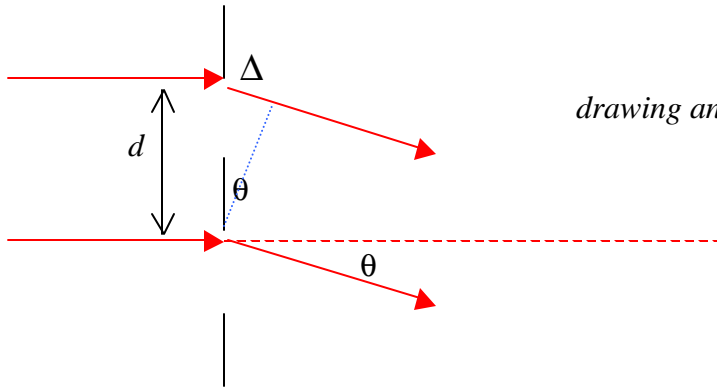

drawing and labels should be complete
[0.6 pts]

Path length difference:

$$\Delta = d \sin \theta , \quad d = \text{spacing of the grating}$$

Diffraction order:

$$\Delta = m \lambda , \quad m = \text{order number}$$

Hence, for the first order ($m = 1$):

$$\sin \theta = \lambda / d \quad [0.4 \text{ pts}]$$

Observation data:

$\tan \theta$	θ	$\sin \theta$	
0.34	18.78°	0.3219	
0.32	17.74°	0.3048	<i>number of data 3</i>
0.32	17.74°	0.3048	[0.5 pts]

Name of component no.1	Specification
Diffraction grating	Spacing = $2.16 \mu\text{m}$
	Lines at right angle to the slit

[0.4 pts]

[0.1 pts]

Note: true value of grating spacing is $2.0 \mu\text{m}$, deviation of the result $\leq 10\%$

5. Diffraction grating **[total 2.0 pts]**:

For the derivation of the formula, see nr.4 above.

[1.0 pts]

Observation data:

$\tan\theta$	θ	$\sin\theta$
1.04	46.12°	0.7208
0.96	43.83°	0.6925
1.08	47.20°	0.7330

number of data ³³

[0.5 pts]

Name of component no.2	Specification
Diffraction grating	Spacing = 0.936 μm Lines parallel to the slit

[0.4 pts]

[0.1 pts]

Note: true value of grating spacing is 1.0 μm , deviation of the result $\leq 10\%$

6. Plan-parallel plate [total 2.0 pts]:

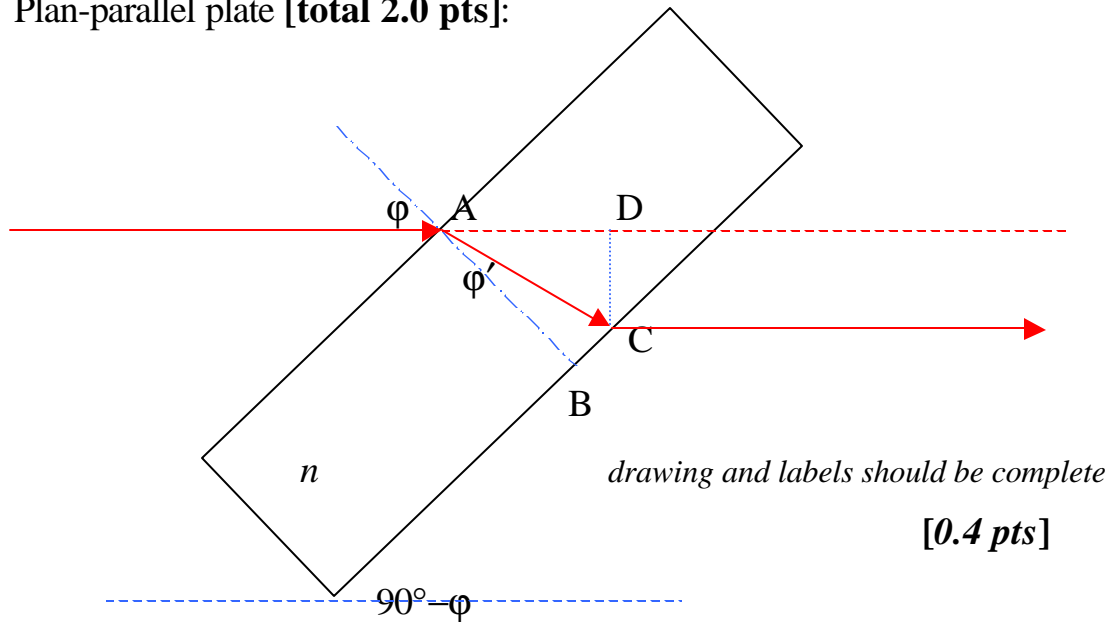

Snell's law:

$$\sin \phi = n \sin \phi' , \quad \phi' = \angle BAC$$

Path length inside the plate:

$$AC = AB / \cos \phi' , \quad AB = h = \text{plate thickness}$$

Beam displacement:

$$CD = t = AC \sin \angle CAD , \quad \angle CAD = \phi - \phi'$$

Hence:

$$t = h \sin \phi \left[1 - \cos \phi / (n^2 - \sin^2 \phi)^{1/2} \right] \quad [0.6 \text{ pts}]$$

Observation data:

ϕ	t	
0	0	(angle between beam and axis 49°)
49°	7.3 arbitrary scale	[0.5 pts]

Name of component no.3	Specification	
Plane-parallel plate	Thickness = 17.9 mm	[0.2 pts]
	Angle to the axis of the box 49°	[0.3 pts]

Note: - true value of plate thickness is 20 mm
 - true value of angle to the axis of the box is 52°
 - deviation of the results ≤ 20%.

Theoretical Question 1

A Swing with a Falling Weight

A rigid cylindrical rod of radius R is held horizontal above the ground. With a string of negligible mass and length L ($L > 2\pi R$), a pendulum bob of mass m is suspended from point A at the top of the rod as shown in Figure 1a. The bob is raised until it is level with A and then released from rest when the string is taut. Neglect any stretching of the string. Assume the pendulum bob may be treated as a mass point and swings only in a plane perpendicular to the axis of the rod. Accordingly, the pendulum bob is also referred to as the *particle*. The acceleration of gravity is \bar{g} .

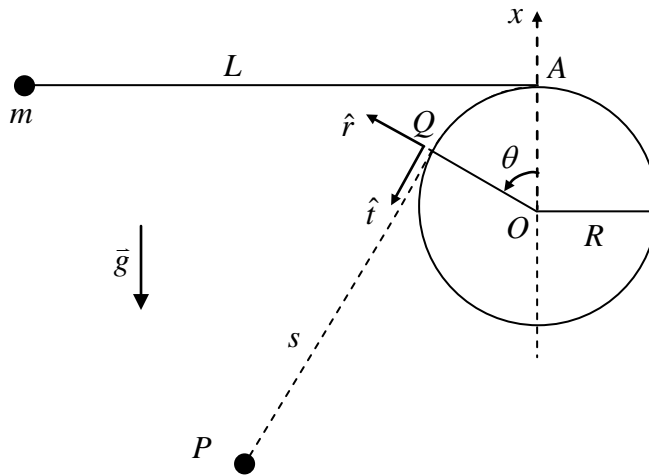

Figure 1a

Let O be the origin of the coordinate system. When the particle is at point P , the string is tangential to the cylindrical surface at Q . The length of the line segment QP is called s . The unit tangent vector and the unit radial vector at Q are given by \hat{t} and \hat{r} , respectively. The angular displacement θ of the radius OQ , as measured counterclockwise from the vertical x -axis along OA , is taken to be positive.

When $\theta = 0$, the length s is equal to L and the gravitational potential energy U of the particle is zero. As the particle moves, the instantaneous time rates of change of θ and s are given by $\dot{\theta}$ and \dot{s} , respectively.

Unless otherwise stated, all the speeds and velocities are relative to the fixed point O .

Part A

In Part A, the string is taut as the particle moves. In terms of the quantities introduced above (i.e., $s, \theta, \dot{s}, \dot{\theta}, R, L, g, \hat{t}$ and \hat{r}), find:

- (a) The relation between $\dot{\theta}$ and \dot{s} . (0.5 point)
- (b) The velocity \bar{v}_Q of the moving point Q relative to O . (0.5 point)
- (c) The particle's velocity \bar{v}' relative to the moving point Q when it is at P (0.7 point)
- (d) The particle's velocity \bar{v} relative to O when it is at P . (0.7 point)

- (e) The \hat{t} -component of the particle's *acceleration* relative to O when it is at P . (0.7 point)
 (f) The particle's gravitational potential energy U when it is at P . (0.5 point)
 (g) The speed v_m of the particle at the lowest point of its trajectory. (0.7 point)

Part B

In Part B, the ratio L to R has the following value:

$$\frac{L}{R} = \frac{9\pi}{8} + \frac{2}{3} \cot \frac{\pi}{16} = 3.534 + 3.352 = 6.886$$

- (h) What is the speed v_s of the particle when the string segment from Q to P is both straight and shortest in length? (in terms of g and R) (2.4 points)
 (i) What is the speed v_H of the particle at its highest point H when it has swung to the other side of the rod? (in terms of g and R) (1.9 points)

Part C

In Part C, instead of being suspended from A , the pendulum bob of mass m is connected by a string over the top of the rod to a heavier weight of mass M , as shown in Figure 1b. The weight can also be treated as a particle.

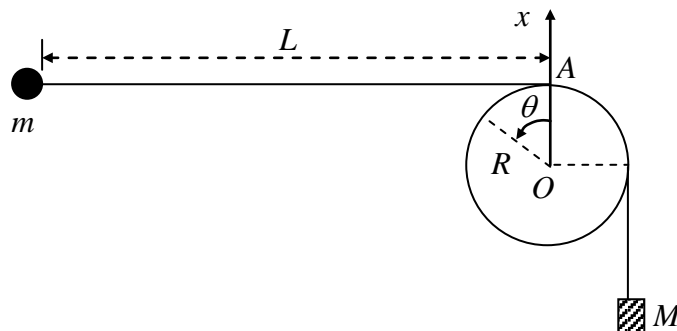

Figure 1b

Initially, the bob is held stationary at the same level as A so that, with the weight hanging below O , the string is taut with a horizontal section of length L . The bob is then released from rest and the weight starts falling. Assume that the bob remains in a vertical plane and can swing past the falling weight without any interruption.

The kinetic friction between the string and the rod surface is negligible. But the static friction is assumed to be large enough so that the weight will remain stationary once it has come to a stop (i.e. zero velocity).

- (j) Assume that the weight indeed comes to a stop after falling a distance D and that $(L - D) \gg R$. If the particle can then swing around the rod to $\theta = 2\pi$ while both segments of the string free from the rod remain straight, the ratio $\alpha = D/L$ must not be smaller than a critical value α_c . Neglecting terms of the order R/L or higher, obtain an estimate on α_c in terms of M/m . (3.4 points)

(a) The relation between $\dot{\theta}$ and \dot{s} is

(b) The velocity of the moving point Q relative to O is

$$\bar{v}_Q =$$

(c) When at P , the particle's velocity relative to the moving point Q is

$$\bar{v}' =$$

(d) When at P , the particle's velocity relative to O is

$$\bar{v} =$$

(e) When at P , the \hat{i} -component of the particle's acceleration relative to O is

(f) When at P , the particle's gravitational potential energy is

$$U =$$

(g) The particle's speed when at the lowest point of its trajectory is

$$v_m =$$

(h) When line segment QP is straight with the shortest length, the particle's speed is
(Give expression and value in terms of g and R)

$$v_s =$$

(i) At the highest point, the particle's speed is (Give expression and value in terms of g and R)

$$v_H =$$

(j) In terms of the mass ratio M/m , the critical value α_c of the ratio D/L is

$$\alpha_c =$$

Theoretical Question 2

A Piezoelectric Crystal Resonator under an Alternating Voltage

Consider a uniform rod of unstressed length ℓ and cross-sectional area A (Figure 2a). Its length changes by $\Delta\ell$ when equal and opposite forces of magnitude F are applied to its ends faces normally. The *stress* T on the end faces is defined to be F/A . The *fractional change* in its length, i.e., $\Delta\ell/\ell$, is called the *strain* S of the rod. In terms of stress and strain, Hooke's law may be expressed as

$$T = Y S \quad \text{or} \quad \frac{F}{A} = Y \frac{\Delta\ell}{\ell} \quad (1)$$

where Y is called the *Young's modulus* of the rod material. Note that a *compressive* stress T corresponds to $F < 0$ and a decrease in length (i.e., $\Delta\ell < 0$). Such a stress is thus negative in value and is related to the pressure p by $T = -p$.

For a uniform rod of density ρ , the speed of propagation of longitudinal waves (i.e., sound speed) along the rod is given by

$$u = \sqrt{Y/\rho} \quad (2)$$

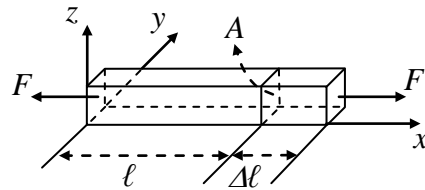

Figure 2a

The effect of damping and dissipation can be ignored in answering the following questions.

Part A: mechanical properties

A uniform rod of semi-infinite length, extending from $x = 0$ to ∞ (see Figure 2b), has a density ρ . It is initially stationary and unstressed. A piston then steadily exerts a small pressure p on its left face at $x = 0$ for a very short time Δt , causing a pressure wave to propagate with *speed* u to the right.

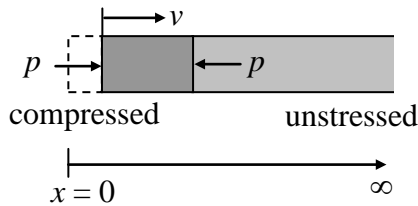

Figure 2b

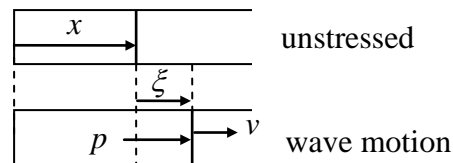

Figure 2c

(a) If the piston causes the rod's left face to move at a constant velocity v (Figure 2b), what are

the strain S and pressure p at the left face during the time Δt ? Answers must be given in terms of ρ , u , and v only. (1.6 points)

(b) Consider a longitudinal wave traveling along the x direction in the rod. For a cross section at x when the rod is unstressed (Figure 2c), let $\xi(x, t)$ be its displacement at time t and assume

$$\xi(x, t) = \xi_0 \sin k(x - ut) \quad (3)$$

where ξ_0 and k are constants. Determine the corresponding velocity $v(x, t)$, strain $S(x, t)$, and pressure $p(x, t)$ as a function of x and t . (2.4 points)

Part B: electromechanical properties (including piezoelectric effect)

Consider a quartz crystal slab of length b , thickness h , and width w (Figure 2d). Its length and thickness are along the x -axis and z -axis. Electrodes are formed by thin metallic coatings at its top and bottom surfaces. Electrical leads that also serve as mounting support (Figure 2e) are soldered to the electrode's centers, which may be assumed to be stationary for longitudinal oscillations along the x direction.

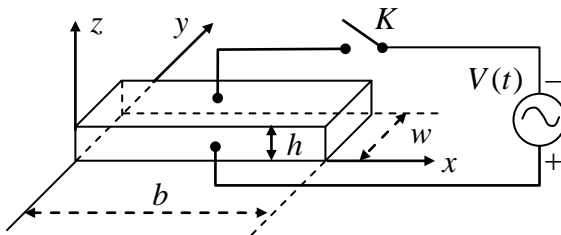

Figure 2d

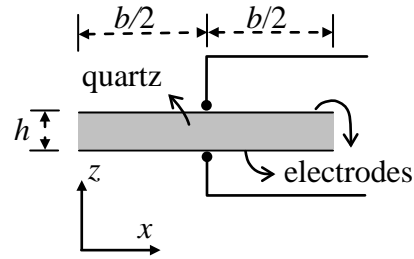

Figure 2e

The quartz crystal under consideration has a density ρ of $2.65 \times 10^3 \text{ kg/m}^3$ and Young's modulus Y of $7.87 \times 10^{10} \text{ N/m}^2$. The length b of the slab is 1.00 cm and the width w and height h of the slab are such that $h \ll w$ and $w \ll b$. With switch K left open, we assume only *longitudinal modes* of standing wave oscillation in the x direction are excited in the quartz slab.

For a standing wave of frequency $f = \omega/2\pi$, the displacement $\xi(x, t)$ at time t of a cross section of the slab with equilibrium position x may be written as

$$\xi(x, t) = 2\xi_0 g(x) \cos \omega t, \quad (0 \leq x \leq b) \quad (4a)$$

where ξ_0 is a positive constant and the spatial function $g(x)$ is of the form

$$g(x) = B_1 \sin k\left(x - \frac{b}{2}\right) + B_2 \cos k\left(x - \frac{b}{2}\right) \quad (4b)$$

$g(x)$ has the maximum value of one and $k = \omega/u$. Keep in mind that the centers of the electrodes are stationary and the left and right faces of the slab are free and must have zero stress (or pressure).

(c) Determine the values of B_1 and B_2 in Eq. (4b) for a longitudinal standing wave in the quartz slab. (1.2 point)

(d) What are the two lowest frequencies at which longitudinal standing waves may be excited in the quartz slab? (1.2 point)

The *piezoelectric* effect is a special property of a *quartz* crystal. Compression or dilatation of the crystal generates an electric voltage across the crystal, and conversely, an external voltage applied across the crystal causes the crystal to expand or contract depending on the polarity of the voltage. Therefore, mechanical and electrical oscillations can be coupled and made to resonate through a quartz crystal.

To account for the piezoelectric effect, let the surface charge densities on the upper and lower electrodes be $-\sigma$ and $+\sigma$, respectively, when the quartz slab is under an electric field E in the z direction. Denote the slab's strain and stress in the x direction by S and T , respectively. Then the piezoelectric effect of the quartz crystal can be described by the following set of equations:

$$S = (1/Y)T + d_p E \quad (5a)$$

$$\sigma = d_p T + \epsilon_T E \quad (5b)$$

where $1/Y = 1.27 \times 10^{-11} \text{ m}^2/\text{N}$ is the *elastic compliance* (i.e., inverse of Young's modulus) at constant electric field and $\epsilon_T = 4.06 \times 10^{-11} \text{ F/m}$ is the *permittivity* at constant stress, while $d_p = 2.25 \times 10^{-12} \text{ m/V}$ is the *piezoelectric coefficient*.

Let switch K in Fig. 2d be closed. The alternating voltage $V(t) = V_m \cos \omega t$ now acts across the electrodes and a *uniform* electric field $E(t) = V(t)/h$ in the z direction appears in the quartz slab. When a steady state is reached, a longitudinal standing wave oscillation of angular frequency ω appears in the slab in the x direction.

With E being uniform, the wavelength λ and the frequency f of a longitudinal standing wave in the slab are still related by $\lambda = u/f$ with u given by Eq. (2). But, as Eq. (5a) shows, $T = YS$ is no longer valid, although the definitions of strain and stress remain unchanged and the end faces of the slab remain free with zero stress.

(e) Taking Eqs. (5a) and (5b) into account, the surface charge density σ on the lower electrode as a function of x and t is of the form,

$$\sigma(x, t) = \left[D_1 \cos k \left(x - \frac{b}{2} \right) + D_2 \right] \frac{V(t)}{h}$$

where $k = \omega/u$. Find the expressions for D_1 and D_2 . (2.2 points)

(f) The total surface charge $Q(t)$ on the lower electrode is related to $V(t)$ by

$$Q(t) = \left[1 + \alpha^2 \left(\frac{2}{kb} \tan \frac{kb}{2} - 1 \right) \right] C_0 V(t) \quad (6)$$

Find the expression for C_0 and the expression and numerical value of α^2 . (1.4 points)

A Piezoelectric Crystal Resonator under an Alternating Voltage

Wherever requested, give each answer as analytical expressions followed by numerical values and units. For example: area of a circle $A = \pi r^2 = 1.23 \text{ m}^2$.

- (a) The strain S and pressure p at the left face are (in terms of ρ , u , and v)

$S =$
$p =$

- (b) The velocity $v(x, t)$, strain $S(x, t)$, and pressure $p(x, t)$ are

$v(x, t) =$
$S(x, t) =$
$p(x, t) =$

- (c) The values of B_1 and B_2 are

$B_1 =$
$B_2 =$

- (d) The lowest two frequencies of standing waves are (expression and value)

The Lowest
The Second Lowest

- (e) The expressions of D_1 and D_2 are

$D_1 =$
$D_2 =$

- (f) The constants α^2 (expression and value) and C_0 are (expression only)

$\alpha^2 =$
$C_0 =$

Theoretical Question 3

Part A

Neutrino Mass and Neutron Decay

A free neutron of mass m_n decays at rest in the laboratory frame of reference into three non-interacting particles: a proton, an electron, and an anti-neutrino. The rest mass of the proton is m_p , while the rest mass of the anti-neutrino m_ν is assumed to be nonzero and much smaller than the rest mass of the electron m_e . Denote the speed of light in vacuum by c . The measured values of mass are as follows:

$$m_n = 939.56563 \text{ MeV}/c^2, m_p = 938.27231 \text{ MeV}/c^2, m_e = 0.5109907 \text{ MeV}/c^2$$

In the following, all energies and velocities are referred to the laboratory frame. Let E be the total energy of the electron coming out of the decay.

- (a) Find the maximum possible value E_{\max} of E and the speed v_m of the anti-neutrino when $E = E_{\max}$. Both answers must be expressed in terms of the rest masses of the particles and the speed of light. Given that $m_\nu < 7.3 \text{ eV}/c^2$, compute E_{\max} and the ratio v_m/c to 3 significant digits. (4.0 points)

Part B

Light Levitation

A transparent glass hemisphere with radius R and mass m has an index of refraction n . In the medium outside the hemisphere, the index of refraction is equal to one. A parallel beam of monochromatic laser light is incident uniformly and normally onto the central portion of its planar surface, as shown in Figure 3. The acceleration of gravity \bar{g} is vertically downwards. The radius δ of the circular cross-section of the laser beam is much smaller than R . Both the glass hemisphere and the laser beam are axially symmetric with respect to the z -axis.

The glass hemisphere does not absorb any laser light. Its surface has been coated with a thin layer of transparent material so that reflections are negligible when light enters and leaves the glass hemisphere. The optical path traversed by laser light passing through the non-reflecting surface layer is also negligible.

- (b) Neglecting terms of the order $(\delta/R)^3$ or higher, find the laser power P needed to balance the weight of the glass hemisphere. (4.0 points)

Hint: $\cos \theta \approx 1 - \theta^2/2$ when θ is much smaller than one.

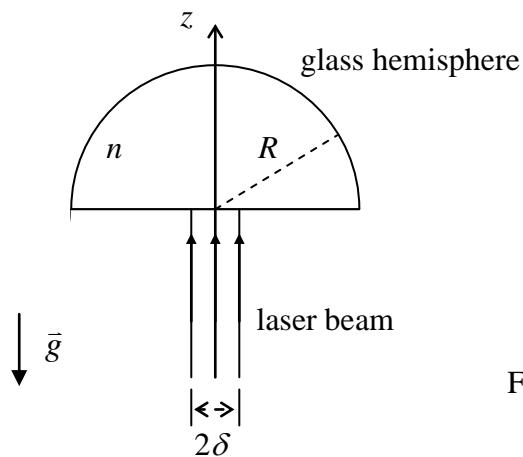

Figure 3

Wherever requested, give each answer as analytical expressions followed by numerical values and units. For example: area of a circle $A = \pi r^2 = 1.23 \text{ m}^2$.

Neutrino Mass and Neutron Decay

(a) (Give expressions in terms of rest masses of the particles and the speed of light)

The maximum energy of the electron is (*expression and value*)

$E_{\text{max}} =$

The ratio of anti-neutrino's speed at $E = E_{\text{max}}$ to c is (*expression and value*)

$v_{\text{m}}/c =$

Light Levitation

(b) The laser power needed to balance the weight of the glass hemisphere is

$P =$

The 34th International Physics Olympiad

Taipei, Taiwan

Experimental Competition

Wednesday, August 6, 2003

Time Available : 5 hours

Please Read This First:

1. Use only the pen provided.
2. Use only the front side of the answer sheets and paper.
3. In your answers please use as little text as possible; express yourself primarily in equations, numbers and figures. If the required result is a numerical number, underline your final result with a wavy line.
4. Write on the blank sheets of paper the results of your measurements and whatever else you consider is required for the solution of the question and that you wish to be marked.
5. It is absolutely essential that you enter in the boxes at the top of each sheet of paper used your *Country* and your student number [*Student No.*]. In addition, on the blank sheets of paper used for each question, you should enter the question number [**Question No. : e.g. A-(1)**], the progressive number of each sheet [*Page No.*] and the total number of blank sheets that you have used and wish to be marked for each question [*Total No. of pages*]. If you use some blank sheets of paper for notes that you do not wish to be marked, put a large cross through the whole sheet and do not include them in your numbering.
6. At the end of the exam please put your answer sheets and graphs in order.
7. **Error bars on graphs are only needed in part A of the experiment.**
8. **Caution: Do not look directly into the laser beam. You can damage your eyes!!**

Apparatuses and materials

1. Available apparatuses and materials are listed in the following table:

Item	Apparatus & material	Quantity	Item	Apparatus & material	Quantity
A	Photodetector (PD)	1	I	Batteries	2
B	Polarizers with Rotary mount	2	J	Battery box	1
C	90° TN-LC cell (yellow wires) with rotary LC mount	1	K	Optical bench	1
D	Function generator	1	L	Partially transparent papers	2
E	Laser diode (LD)	1	M	Ruler	1
F	Multimeters	2	N	White tape * (for marking on apparatus)	1
G	Parallel LC cell (orange wires)	1	O	Scissors	1
H	Variable resistor	1	P	Graph papers	10

* Do not mark directly on apparatus. When needed, stick a piece of the white tape on the parts and mark on the white tape.

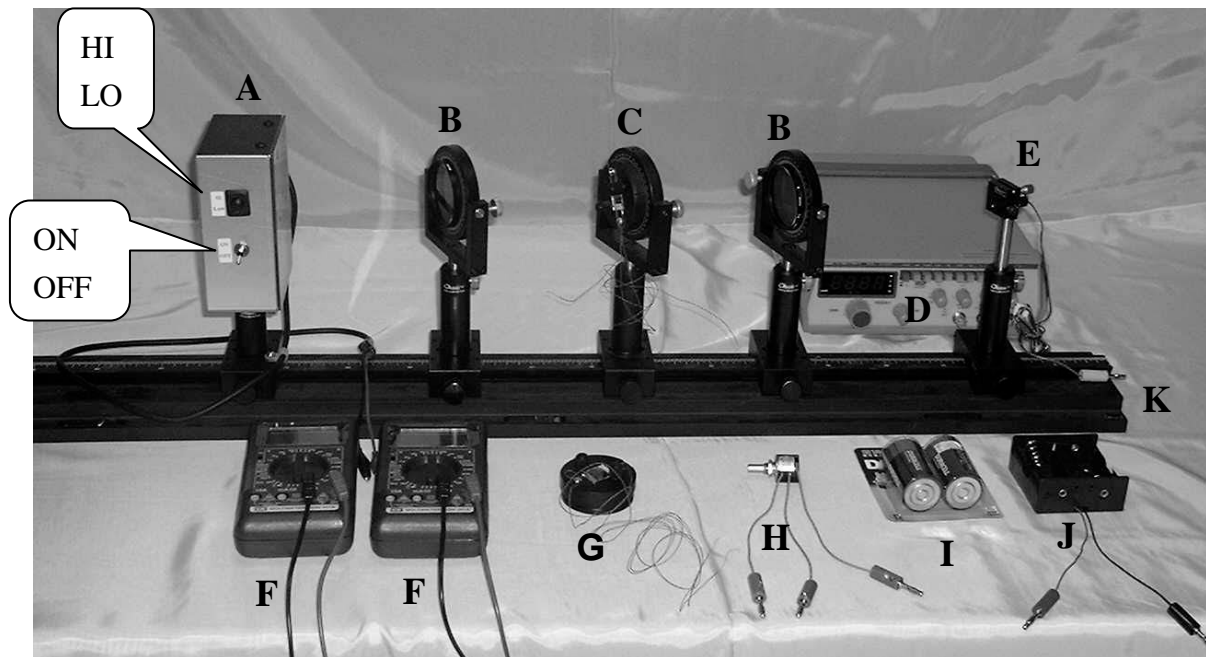

Fig. 1

2. Instructions for the multimeter:

- “DC/AC” switch for selecting DC or AC measurement.
- Use the “VΩ” and the “COM” inlets for voltage and resistance measurements.
- Use the “mA” and the “COM” inlets for small current measurements. The display then shows the current in milliamperes.
- Use the function dial to select the proper function and measuring range. “V” is for voltage measurement, “A” is for current measurement and “Ω” is for resistance measurement.

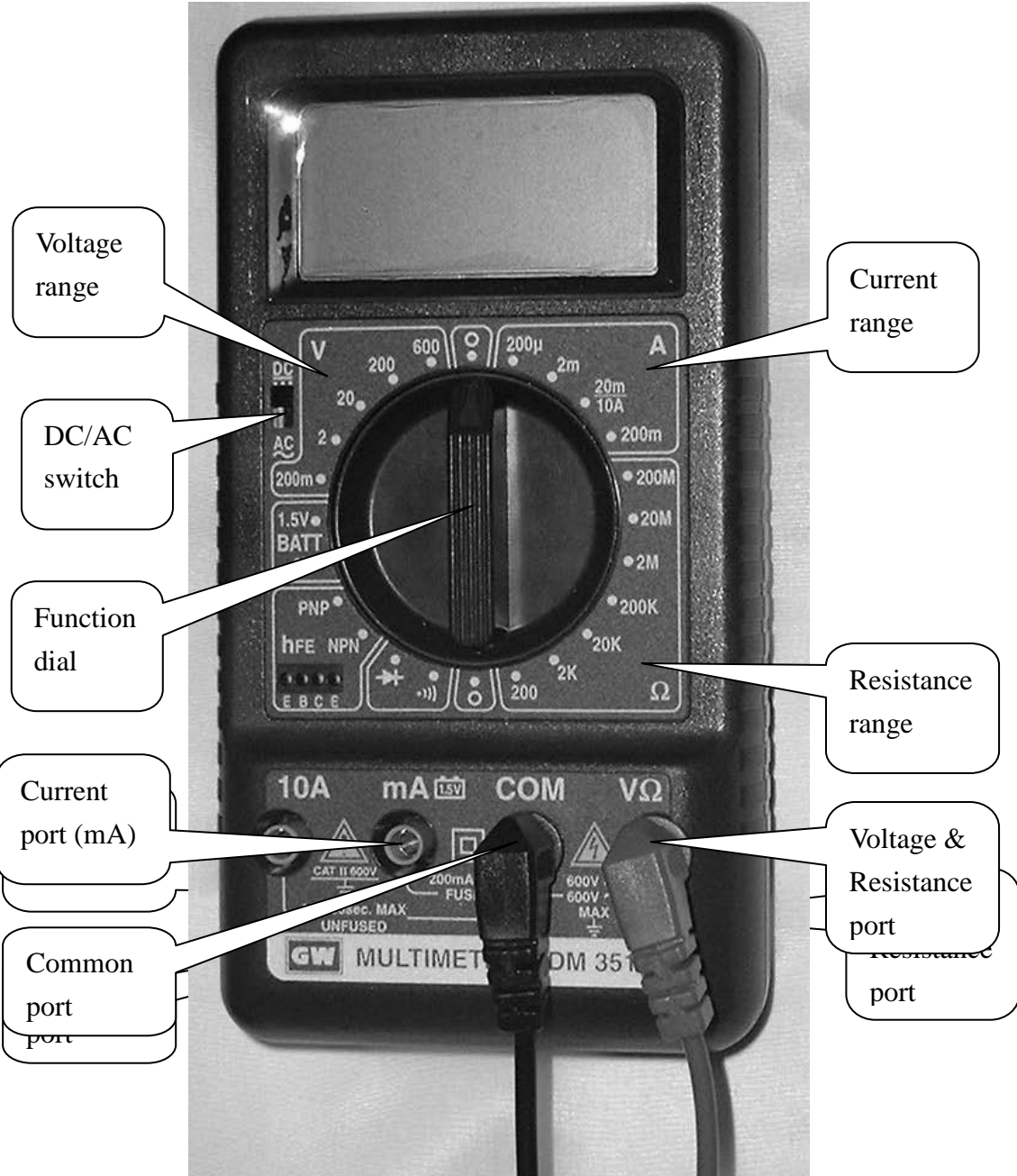

Fig. 2

3. Instructions for the Function Generator:

- The power button may be pressed for “ON” and pressed again for “OFF”
- Select the frequencies range, and press the proper button.
- The frequency is shown on the digital display.
- Use the coarse and the fine frequency adjusting knobs to tune the proper frequency.
- Select the square-wave form by pressing the left most waveform button.
- Use the amplitude-adjusting knob to vary the output voltage.

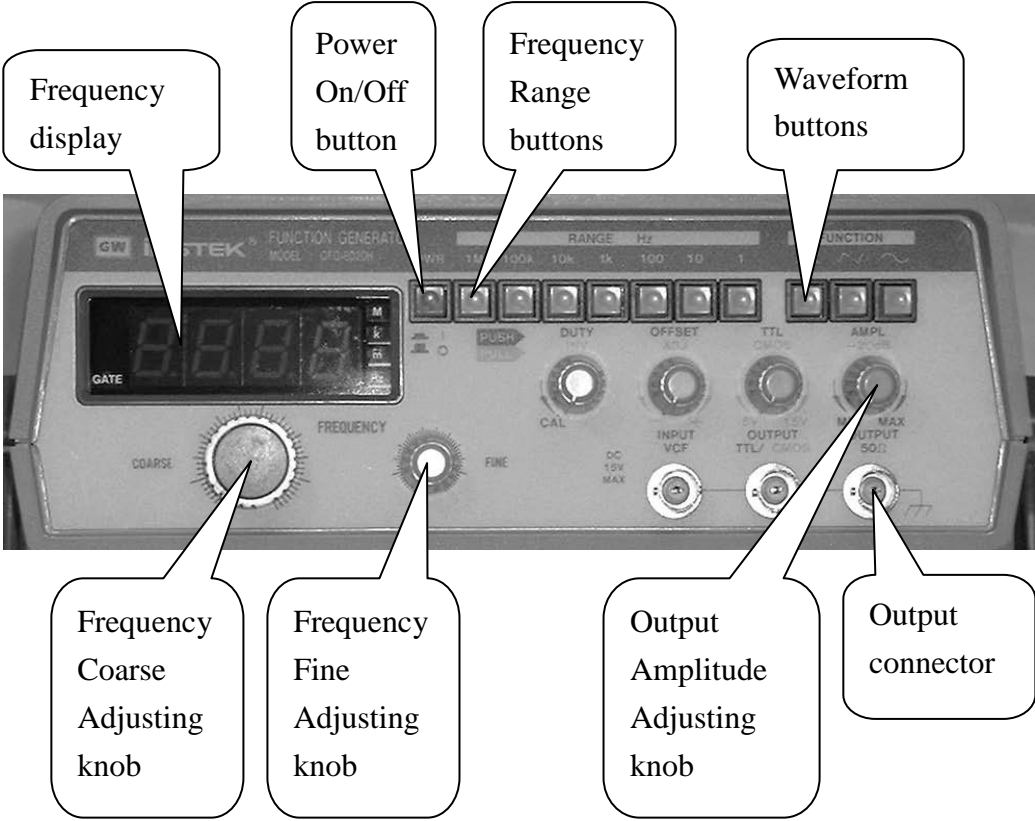

Fig.3

Part A: Optical Properties of Laser Diode

I. Introduction

1. Laser Diode

The light source in this experiment is a laser diode which emits laser light with wavelength 650 nm. When the current of the laser diode (LD) is greater than the threshold current, the laser diode can emit monochromatic, partially polarized and coherent light. When the current in the laser diode is less than the threshold, the emitted light intensity is very small. At above the threshold current, the light intensity increases dramatically with the current and keeps a linear relationship with the current. If the current increases further, then the increasing rate of the intensity with respect to the current becomes smaller because of the higher temperature of the laser diode. Therefore, the optimal operating current range for the laser diode is the region where the intensity is linear with the current. In general, the threshold current I_{th} is defined as the intersection point of the current axis with the extrapolation line of the linear region.

Caution: Do not look directly into the laser beam. You can damage your eyes!!

2. Photodetector

The photodetector used in this experiment consists of a photodiode and a current amplifier. When an external bias voltage is applied on the photodiode, the photocurrent is generated by the light incident upon the diode. Under the condition of a constant temperature and monochromatic incident light, the photocurrent is proportional to the light intensity. On the other hand, the current amplifier is utilized to transfer the photocurrent into an output voltage. There are two transfer ratios in our photodetector – high and low gains. In our experiment, only the low gain is used. However, because of the limitation of the photodiode itself, the output voltage would go into saturation at about 8 Volts if the light intensity is too high and the photodiode cannot operate properly any more. Hence the appropriate operating range of the photodetector is when the output voltage is indeed proportional to the light intensity. If the light intensity is too high so that the photodiode reaches the saturation, the reading of the photodetector can not correctly represent the incident light intensity.

II. Experiments and procedures

Characteristics of the laser diode & the photodetector

In order to make sure the experiments are done successfully, the optical alignment of

light rays between different parts of an experimental setup is crucial. Also the light source and the detector should be operated at proper condition. Part A is related to these questions and the question of the degree of polarization.

1. Mount the laser diode and photodetector in a horizontal line on the optical bench, as shown in Fig. 4. Connect the variable resistor, battery set, ampere meter, voltage meter, laser diode and photodetector according to Fig. 5. Adjust the variable resistor so that the current passing through LD is around 25 mA and the laser diode emits laser light properly. Choose the low gain for the photodetector. Align the laser diode and the photodetector to make the laser light level at the small hole on the detector box and the reading of the photodetector reaches a maximum value.

Caution: Do not let the black and the red leads of the battery contact with each other to avoid short circuit.

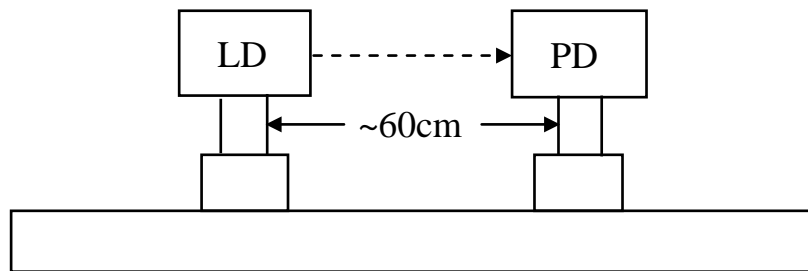

Fig. 4 Optical setup (LD : laser diode; PD : photodetector).

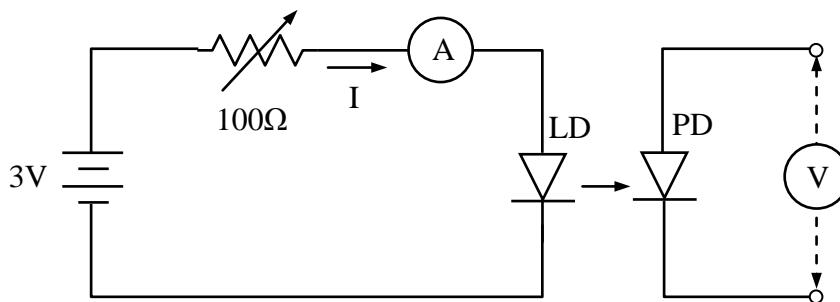

Fig. 5 Equivalent circuit for the connection of the laser diode.

2. Use the output voltage of the photodetector to represent the laser light intensity J . Adjust the variable resistor to make the current I of the laser diode varying from zero to a maximum value and measure the J as I increases. Be sure to choose appropriate current increment in the measurement.

Question A-(1) (1.5 point)

Measure, tabulate, and plot the J vs. I curve.

Question A-(2) (3.5 points)

Estimate the maximum current I_m with uncertainty in the linear region of the J vs. I curve. Mark the linear region on the $J - I$ curve figure by using arrows (\downarrow) and determine the threshold current I_{th} with uncertainty.

3. Choose the current of the laser diode as $I_{th} + 2(I_m - I_{th})/3$ to make sure the laser diode and photodetector are operated well.
4. **To prepare for the part B experiment:** Mount a polarizer on the optical bench close to the laser diode as shown in Fig. 6. Make sure the laser beam passing through the center portion of the polarizer. Adjust the polarizer so that the incident laser beam is perpendicular to the plane of the polarizer. (Hint: You can insert a piece of partially transparent paper as a test screen to check if the incident and reflected light spots coincide with each other.)

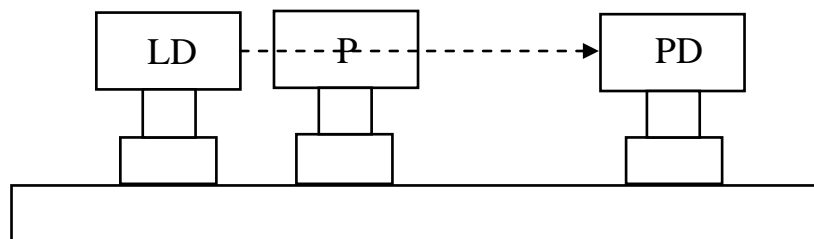

Fig. 6 Alignment of the polarizer (P : polarizer).

5. Keep the current of the laser diode unchanged, mount a second piece of polarizer on the optical bench and make sure proper alignment is accomplished, *i.e.*, set up the source, detector and polarizers in a straight line and make sure each polarizer plane is perpendicular to the light beam.

Part B Optical Properties of Nematic Liquid Crystal :

Electro-optical switching characteristic of 90° TN LC cell

I. Introduction

1. Liquid Crystal

Liquid crystal (LC) is a state of matter that is intermediate between the crystalline solid and the amorphous liquid. The nematic LCs are organic compounds consist of long-shaped needle-like molecules. The orientation of the molecules can be easily aligned and controlled by applying an electrical field. Uniform or well prescribed orientation of the LC molecules is required in most LC devices. The structure of the LC cell used in this experiment is shown in Fig 7. Rubbing the polyimide film can produce a well-aligned preferred orientation for LC molecules on substrate surfaces, thus due to the molecular interaction the whole slab of LC can achieve uniform molecular orientation. The local molecular orientation is called the director of LC at that point.

The LC cell exhibits the so-called double refraction phenomenon with two principal refractive indices. When light propagates along the direction of the director, all polarization components travel with the same speed $v_o = c/n_o$, where n_o is called the ordinary index of refraction. This propagation direction (direction of the director) is called the optic axis of the LC cell. When a light beam propagates in the direction perpendicular to the optic axis, in general, there are two speeds of propagation. The electric field of the light polarized perpendicular (or parallel) to the optic axis travels with the speed of $v_o = c/n_o$ (or $v_e = c/n_e$, where n_e is called the extraordinary index of refraction). The birefringence (optical anisotropy) is defined as the difference between the extraordinary and the ordinary indices of refraction $\Delta n \equiv n_e - n_o$.

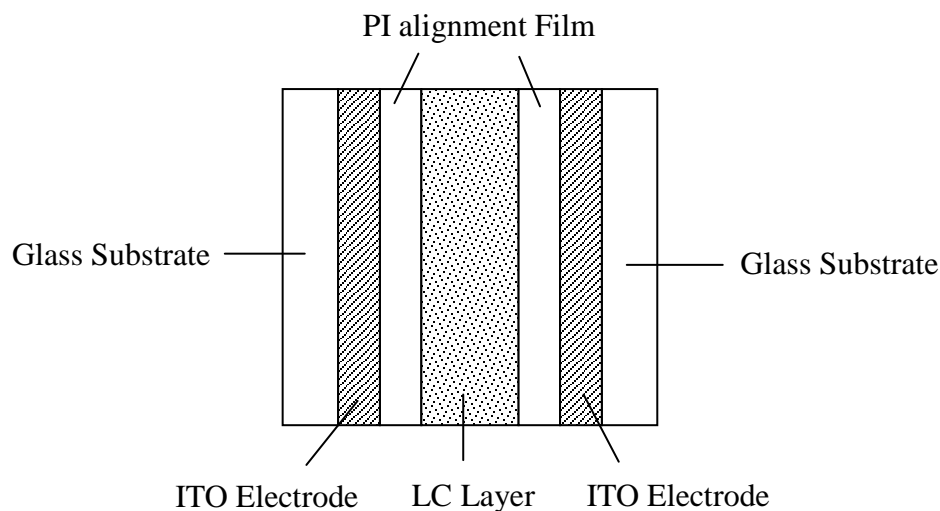

Fig. 7 LC cell structure

2. 90° Twisted Nematic LC Cell

In the 90° twisted nematic (TN) cell shown in Fig. 8, the LC director of the back surface is twisted 90° with respect to the front surface. The front local director is set parallel to the transmission axis of the polarizer. An incident unpolarized light is converted into a linearly polarized light by the front polarizer.

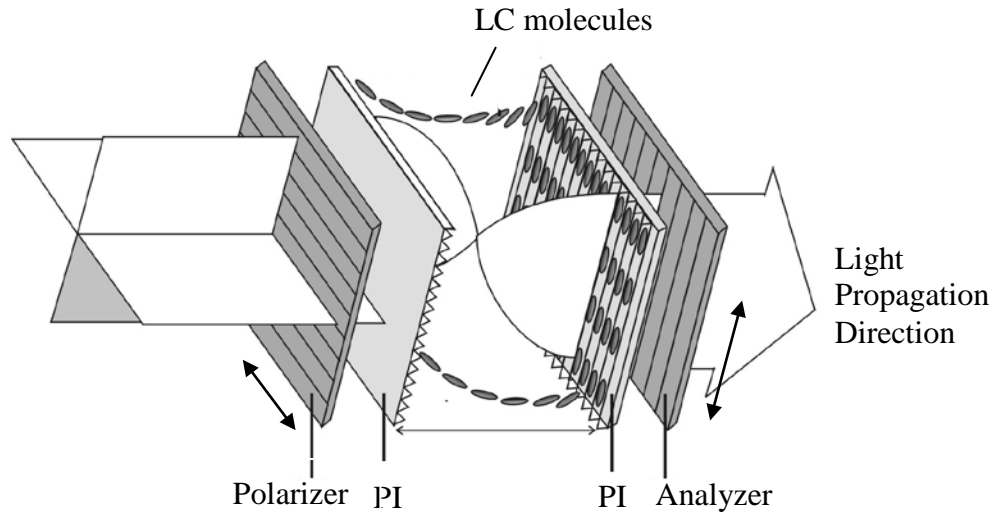

Fig. 8 90° TN LC cell

When a linearly polarized light traverses through a 90° TN cell, its polarization follows the twist of the LC directors (polarized light sees n_e only) so that the output beam remains linearly polarized except for that its polarization axis is rotated by 90° (it's called the polarizing rotary effect by n_e ; similarly we can also find polarizing rotary effect by n_o). Thus, for a normally black (NB) mode using a 90° TN cell, the analyzer's (a second polarizer) transmission axis is set to be parallel to the polarizer's transmission axis, as shown in Fig. 9. However, when the applied voltage V across the LC cell exceeds a critical value V_c , the director of LC molecules tends to align along the direction of applied external electrical field which is in the direction of the propagation of light. Hence, the polarization guiding effect of the LC cell is gradually diminishing and the light leaks through the analyzer. Its electro-optical switching slope γ is defined as $(V_{90} - V_{10})/V_{10}$, where V_{10} and V_{90} are the applied voltages enabling output light signal reaches up to 10% and 90% of its maximum light intensity, respectively.

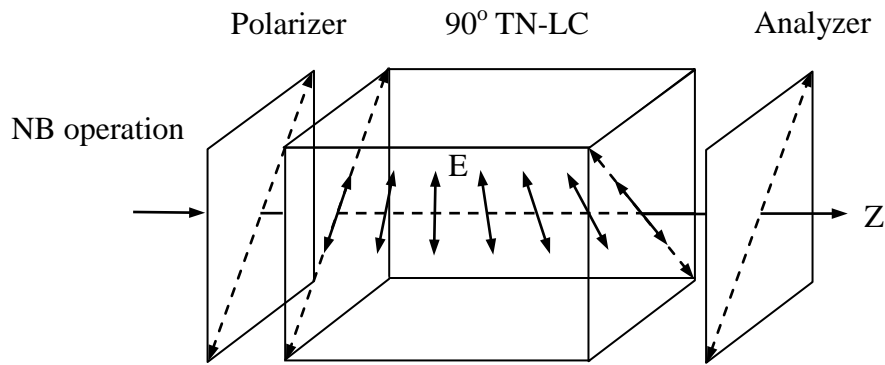

Fig. 9 NB mode operation of a 90° TN cell

II. Experiments and procedures

1. Setup a NB 90° TN LC mode between two polarizers with parallel transmission axes and apply 100 Hz square wave voltage using a function generator onto the ITO portions of two glass substrates and vary the applied voltage (V_{rms}) from 0 to 7.2 Volts.

* In the crucial turning points, take more data if necessary.

Question B-(1) (5.0 points)

Measure, tabulate, and plot the electro-optical switching curve (J vs. V_{rms} curve) of the NB 90° TN LC, and find its switching slope γ , where γ is defined as $(V_{90} - V_{10})/V_{10}$.

Question B-(2) (2.5 points)

Determine the critical voltage V_c of this NB 90° TN LC cell. Show explicitly with graph how you determine the value V_c .

Hint:* When the external applied voltage exceeds the critical voltage, the light transmission increases rapidly and abruptly.

Part C Optical Properties of Nematic Liquid Crystal :

Electro-optical switching characteristic of parallel aligned LC cell

I. Introduction

Homogeneous Parallel-aligned LC Cell

For a parallel-aligned LC cell, the directors in the front and back substrates are parallel with each other, as shown in Fig. 10. When a linearly polarized light impinges on a parallel-aligned cell with its polarization parallel to the LC director (rubbing direction), a pure phase modulation is achieved because the light behaves only as an extraordinary ray.

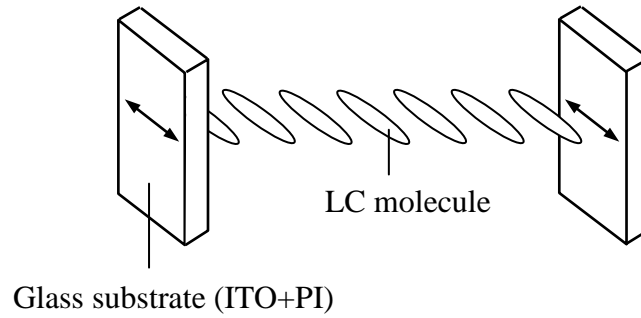

Fig. 10 Homogeneous parallel aligned LC

On the other hand, if a linearly polarized light is normally incident onto a parallel aligned cell but with its polarization making $\theta = 45^\circ$ relative to the direction of the aligned LC directors (Fig. 11), then phase retardation occurs due to the different propagating speed of the extraordinary and ordinary rays in the LC medium. In this $\theta = 45^\circ$ configuration, when the two polarizers are parallel, the normalized transmission of a parallel aligned LC cell is given by

$$T_{\parallel} = \cos^2 \frac{\delta}{2}$$

The phase retardation δ is expressed as

$$\delta = 2\pi d \Delta n(V, \lambda) / \lambda$$

where d is the LC layer thickness, λ is the wavelength of light in air, V is the root mean square of applied AC voltage, and Δn , a function of λ and V , is the LC birefringence. It should be also noted that, at $V = 0$, $\Delta n (= n_e - n_o)$ has its maximum value, so does δ . Also Δn decreases as V increases.

In the general case, we have

$$T_{\parallel} = 1 - \sin^2 2\theta \sin^2 \frac{\delta}{2}$$

$$T_{\perp} = \sin^2 2\theta \sin^2 \frac{\delta}{2}$$

where // and \perp represent that the transmission axis of analyzer is parallel and perpendicular to that of the polarizer, respectively.

II. Experiments and procedures

1. Replace NB 90° TN LC cell with parallel-aligned LC cell.
2. Set up $\theta = 45^\circ$ configuration at $V = 0$ as shown in Fig. 11. Let the analyzer's transmission axis perpendicular to that of the polarizer, then rotate the parallel-aligned LC cell until the intensity of the transmitted light reaches the maximum value (T_{\perp}). This procedure establishes the $\theta = 45^\circ$ configuration. Take down T_{\perp} value, then, measure the intensity of the transmitted light ($T_{//}$) of the same LC cell at the analyzer's transmission axis parallel to that of the polarizer (also at $V = 0$).

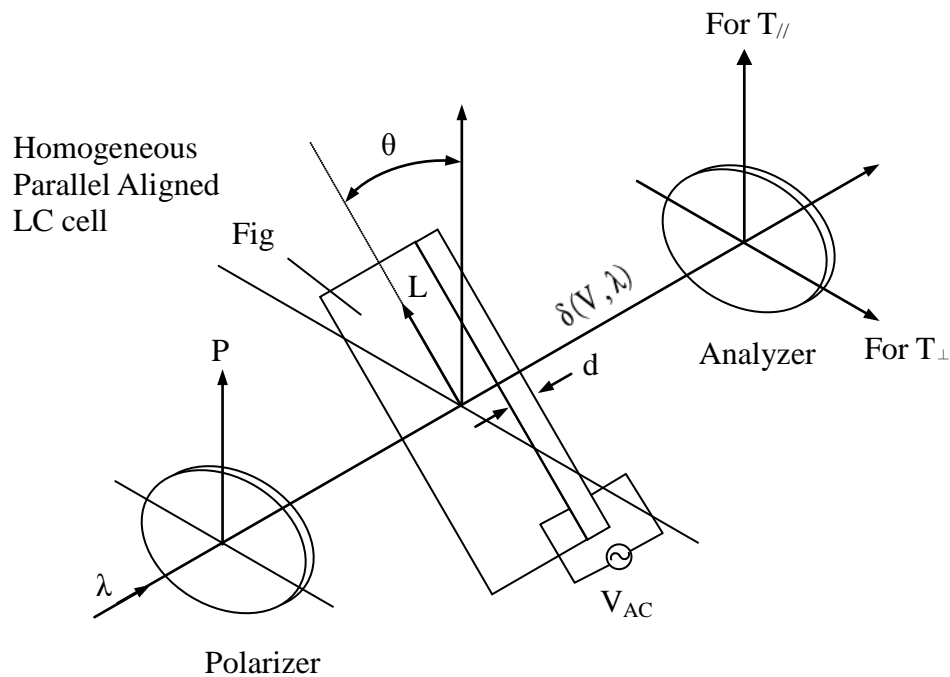

Fig. 11 Schematic diagram of experimental setup
(The arrow L is the alignment direction.)

Question C-(1) (2.5 points)

Assume that the wavelength of laser light 650 nm, LC layer thickness $7.7 \mu\text{m}$, and approximate value of $\Delta n \approx 0.25$ are known. From the experimental data T_{\perp} and $T_{//}$ obtained above, calculate the accurate value of the phase retardation δ and accurate value of birefringence Δn of this LC cell at $V=0$.

3. Similar to the above experiment (1), in the $\theta = 45^\circ$ configuration, apply 100 Hz square wave voltage using a function generator onto the ITO portions of two glass substrates, vary the applied voltage (V_{rms}) from 0 to 7 Volts and measure the electro-optical switching curve (T_{\parallel}) at the analyzer's transmission axis parallel to the polarizer's transmission axis. (Hint: Measuring the T_{\perp} switching curve is helpful to increase the data accuracy of the above T_{\parallel} measurement; the data of T_{\perp} are not needed in the following questions.)
- * In the crucial turning points, take more data if necessary (especially in the range of 0.5-4.0 Volts).**

Question C-(2) (3.0 points)

Measure, tabulate, and plot the electro-optical switching curve for T_{\parallel} of this parallel aligned LC cell in the $\theta = 45^\circ$ configuration.

Question C-(3) (2.0 points)

From the electro-optical switching data, find the value of the external applied voltage V_{π} .

Hint: * V_{π} is the applied voltage which enables the phase retardation of this anisotropic LC cell become π (or 180°).

* Remember that Δn is a function of applied voltage, and Δn decreases as V increases.

* Interpolation is probably needed when you determine the accurate value of this V_{π} .

Solution to Theoretical Question 1

A Swing with a Falling Weight

Part A

- (a) Since the length of the string $L = s + R\theta$ is constant, its rate of change must be zero. Hence we have

$$\dot{s} + R\dot{\theta} = 0 \quad (\text{A1})$$

- (b) Relative to O , Q moves on a circle of radius R with angular velocity $\dot{\theta}$, so

$$\vec{v}_Q = R\dot{\theta}\hat{t} = -\dot{s}\hat{t} \quad (\text{A2})$$

- (c) Refer to Fig. A1. Relative to Q , the displacement of P in a time interval Δt is $\Delta\vec{r}' = (s\Delta\theta)(-\hat{r}) + (\Delta s)\hat{t} = [(s\dot{\theta})(-\hat{r}) + \dot{s}\hat{t}]\Delta t$. It follows

$$\vec{v}' = -s\dot{\theta}\hat{r} + \dot{s}\hat{t} \quad (\text{A3})$$

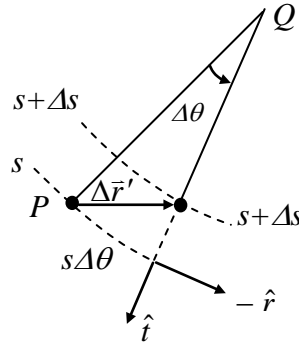

Figure A1

- (d) The velocity of the particle relative to O is the sum of the two relative velocities given in Eqs. (A2) and (A3) so that

$$\vec{v} = \vec{v}' + \vec{v}_Q = (-s\dot{\theta}\hat{r} + \dot{s}\hat{t}) + R\dot{\theta}\hat{t} = -s\dot{\theta}\hat{r} \quad (\text{A4})$$

- (e) Refer to Fig. A2. The $(-\hat{t})$ -component of the velocity change $\Delta\vec{v}$ is given by $(-\hat{t}) \cdot \Delta\vec{v} = v\Delta\theta = v\dot{\theta}\Delta t$. Therefore, the \hat{t} -component of the acceleration $\vec{a} = \Delta\vec{v}/\Delta t$ is given by $\hat{t} \cdot \vec{a} = -v\dot{\theta}$. Since the speed v of the particle is $s\dot{\theta}$ according to Eq. (A4), we see that the \hat{t} -component of the particle's acceleration at P is given by

$$\vec{a} \cdot \hat{t} = -v\dot{\theta} = -(s\dot{\theta})\dot{\theta} = -s\dot{\theta}^2 \quad (\text{A5})$$

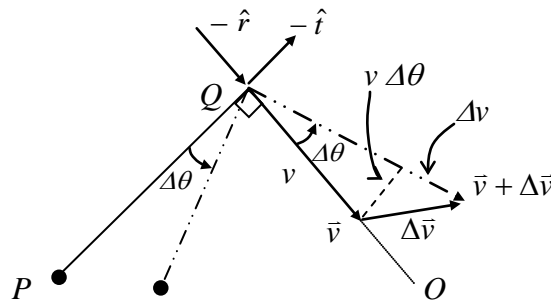

Figure A2

Note that, from Fig. A2, the radial component of the acceleration may also be obtained as

$$\bar{a} \cdot \hat{r} = -dv/dt = -d(s\dot{\theta})/dt.$$

- (f) Refer to Fig. A3. The gravitational potential energy of the particle is given by $U = -mgh$. It may be expressed in terms of s and θ as

$$U(\theta) = -mg[R(1 - \cos \theta) + s \sin \theta] \quad (\text{A6})$$

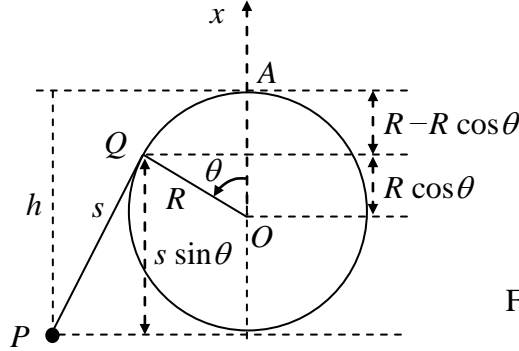

Figure A3

- (g) At the lowest point of its trajectory, the particle's gravitational potential energy U must assume its minimum value U_m . By differentiating Eq. (A6) with respect to θ and using Eq. (A1), the angle θ_m corresponding to the minimum gravitational energy can be obtained.

$$\begin{aligned} \frac{dU}{d\theta} &= -mg \left(R \sin \theta + \frac{ds}{d\theta} \sin \theta + s \cos \theta \right) \\ &= -mg [R \sin \theta + (-R) \sin \theta + s \cos \theta] \\ &= -mgs \cos \theta \end{aligned}$$

At $\theta = \theta_m$, $\left. \frac{dU}{d\theta} \right|_{\theta_m} = 0$. We have $\theta_m = \frac{\pi}{2}$. The lowest point of the particle's trajectory is shown in Fig. A4 where the length of the string segment of QP is $s = L - \pi R/2$.

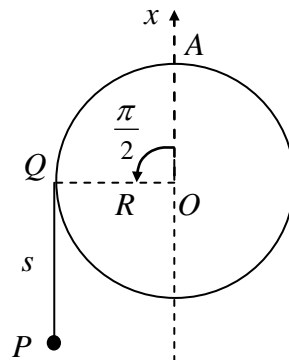

Figure A4

From Fig. A4 or Eq. (A6), the minimum potential energy is then

$$U_m = U(\pi/2) = -mg[R + L - (\pi R/2)] \quad (\text{A7})$$

Initially, the total mechanical energy E is 0. Since E is conserved, the speed v_m of the particle at the lowest point of its trajectory must satisfy

$$E = 0 = \frac{1}{2}mv_m^2 + U_m \quad (\text{A8})$$

From Eqs. (A7) and (A8), we obtain

$$v_m = \sqrt{-2U_m / m} = \sqrt{2g[R + (L - \pi R / 2)]} \quad (\text{A9})$$

Part B

(h) From Eq. (A6), the total mechanical energy of the particle may be written as

$$E = 0 = \frac{1}{2}mv^2 + U(\theta) = \frac{1}{2}mv^2 - mg[R(1 - \cos \theta) + s \sin \theta] \quad (\text{B1})$$

From Eq. (A4), the speed v is equal to $s\dot{\theta}$. Therefore, Eq. (B1) implies

$$v^2 = (s\dot{\theta})^2 = 2g[R(1 - \cos \theta) + s \sin \theta] \quad (\text{B2})$$

Let T be the tension in the string. Then, as Fig. B1 shows, the \hat{t} -component of the net force on the particle is $-T + mg \sin \theta$. From Eq. (A5), the tangential acceleration of the particle is $(-s\dot{\theta}^2)$. Thus, by Newton's second law, we have

$$m(-s\dot{\theta}^2) = -T + mg \sin \theta \quad (\text{B3})$$

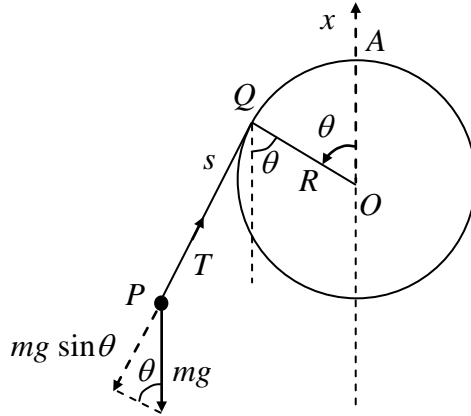
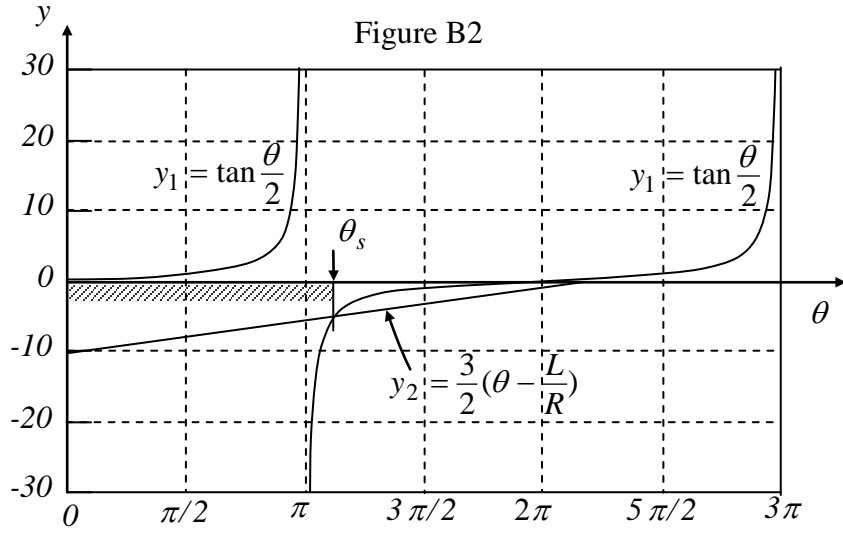

Figure B1

According to the last two equations, the tension may be expressed as

$$\begin{aligned} T &= m(s\dot{\theta}^2 + g \sin \theta) = \frac{mg}{s}[2R(1 - \cos \theta) + 3s \sin \theta] \\ &= \frac{2mgR}{s}\left[\tan \frac{\theta}{2} - \frac{3}{2}\left(\theta - \frac{L}{R}\right)\right](\sin \theta) \\ &= \frac{2mgR}{s}(y_1 - y_2)(\sin \theta) \end{aligned} \quad (\text{B4})$$

The functions $y_1 = \tan(\theta/2)$ and $y_2 = 3(\theta - L/R)/2$ are plotted in Fig B2.



From Eq. (B4) and Fig. B2, we obtain the result shown in Table B1. The angle at which $y_2 = y_1$ is called θ_s ($\pi < \theta_s < 2\pi$) and is given by

$$\frac{3}{2}(\theta_s - \frac{L}{R}) = \tan \frac{\theta_s}{2} \quad (\text{B5})$$

or, equivalently, by

$$\frac{L}{R} = \theta_s - \frac{2}{3} \tan \frac{\theta_s}{2} \quad (\text{B6})$$

Since the ratio L/R is known to be given by

$$\frac{L}{R} = \frac{9\pi}{8} + \frac{2}{3} \cot \frac{\pi}{16} = (\pi + \frac{\pi}{8}) - \frac{2}{3} \tan \frac{1}{2}(\pi + \frac{\pi}{8}) \quad (\text{B7})$$

one can readily see from the last two equations that $\theta_s = 9\pi/8$.

Table B1

	$(y_1 - y_2)$	$\sin \theta$	tension T
$0 < \theta < \pi$	positive	positive	positive
$\theta = \pi$	$+\infty$	0	positive
$\pi < \theta < \theta_s$	negative	negative	positive
$\theta = \theta_s$	zero	negative	zero
$\theta_s < \theta < 2\pi$	positive	negative	negative

Table B1 shows that the tension T must be positive (or the string must be taut and straight) in the angular range $0 < \theta < \theta_s$. Once θ reaches θ_s , the tension T becomes zero and the part of the string not in contact with the rod will not be straight afterwards. The shortest possible value s_{\min} for the length s of the line segment QP therefore occurs at $\theta = \theta_s$ and is given by

$$s_{\min} = L - R\theta_s = R\left(\frac{9\pi}{8} + \frac{2}{3}\cot\frac{\pi}{16} - \frac{9\pi}{8}\right) = \frac{2R}{3}\cot\frac{\pi}{16} = 3.352R \quad (\text{B8})$$

When $\theta = \theta_s$, we have $T = 0$ and Eqs. (B2) and (B3) then leads to $v_s^2 = -gs_{\min} \sin \theta_s$.

Hence the speed v_s is

$$\begin{aligned} v_s &= \sqrt{-gs_{\min} \sin \theta_s} = \sqrt{\frac{2gR}{3}\cot\frac{\pi}{16}\sin\frac{\pi}{8}} = \sqrt{\frac{4gR}{3}}\cos\frac{\pi}{16} \\ &= 1.133\sqrt{gR} \end{aligned} \quad (\text{B9})$$

- (i) When $\theta \geq \theta_s$, the particle moves like a projectile under gravity. As shown in Fig. B3, it is projected with an initial speed v_s from the position $P = (x_s, y_s)$ in a direction making an angle $\phi = (3\pi/2 - \theta_s)$ with the y -axis.

The speed v_H of the particle at the highest point of its parabolic trajectory is equal to the y -component of its initial velocity when projected. Thus,

$$v_H = v_s \sin(\theta_s - \pi) = \sqrt{\frac{4gR}{3}}\cos\frac{\pi}{16}\sin\frac{\pi}{8} = 0.4334\sqrt{gR} \quad (\text{B10})$$

The horizontal distance H traveled by the particle from point P to the point of maximum height is

$$H = \frac{v_s^2 \sin 2(\theta_s - \pi)}{2g} = \frac{v_s^2}{2g} \sin \frac{9\pi}{4} = 0.4535R \quad (\text{B11})$$

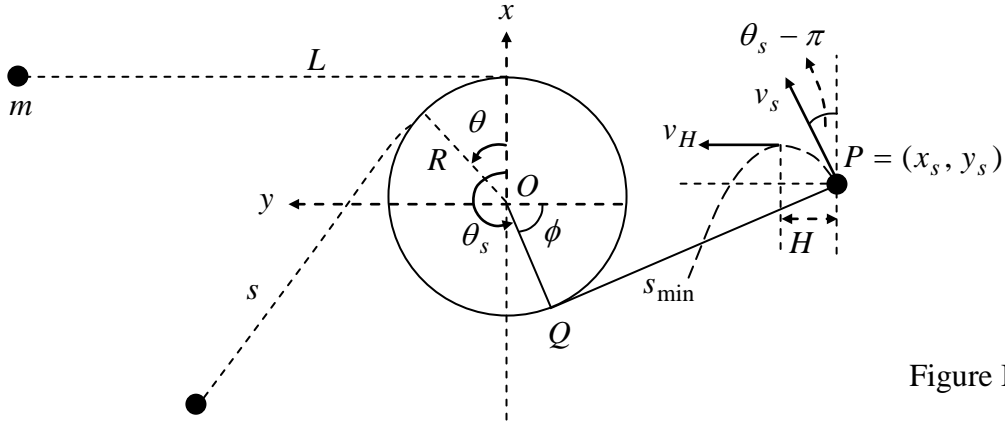

Figure B3

The coordinates of the particle when $\theta = \theta_s$ are given by

$$x_s = R \cos \theta_s - s_{\min} \sin \theta_s = -R \cos \frac{\pi}{8} + s_{\min} \sin \frac{\pi}{8} = 0.358R \quad (\text{B12})$$

$$y_s = R \sin \theta_s + s_{\min} \cos \theta_s = -R \sin \frac{\pi}{8} - s_{\min} \cos \frac{\pi}{8} = -3.478R \quad (\text{B13})$$

Evidently, we have $|y_s| > (R + H)$. Therefore the particle can indeed reach its maximum height without striking the surface of the rod.

Part C

(j) Assume the weight is initially lower than O by h as shown in Fig. C1.

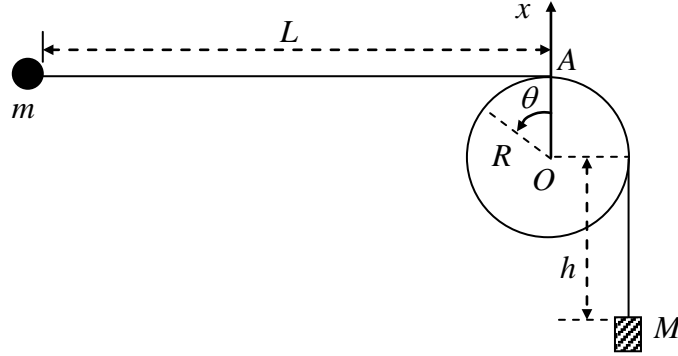

Figure C1

When the weight has fallen a distance D and stopped, the law of conservation of total mechanical energy as applied to the particle-weight pair as a system leads to

$$-Mgh = E' - Mg(h + D) \quad (\text{C1})$$

where E' is the *total mechanical energy of the particle* when the weight has stopped. It follows

$$E' = MgD \quad (\text{C2})$$

Let A be the total length of the string. Then, its value at $\theta = 0$ must be the same as at any other angular displacement θ . Thus we must have

$$A = L + \frac{\pi}{2}R + h = s + R\left(\theta + \frac{\pi}{2}\right) + (h + D) \quad (\text{C3})$$

Noting that $D = \alpha L$ and introducing $\ell = L - D$, we may write

$$\ell = L - D = (1 - \alpha)L \quad (\text{C4})$$

From the last two equations, we obtain

$$s = L - D - R\theta = \ell - R\theta \quad (\text{C5})$$

After the weight has stopped, the total mechanical energy of the particle must be conserved. According to Eq. (C2), we now have, instead of Eq. (B1), the following equation:

$$E' = MgD = \frac{1}{2}mv^2 - mg\left[R(1 - \cos\theta) + s \sin\theta\right] \quad (\text{C6})$$

The square of the particle's speed is accordingly given by

$$v^2 = (s\dot{\theta})^2 = \frac{2MgD}{m} + 2gR\left[(1 - \cos\theta) + \frac{s}{R} \sin\theta\right] \quad (\text{C7})$$

Since Eq. (B3) still applies, the tension T of the string is given by

$$-T + mg \sin\theta = m(-s\dot{\theta}^2) \quad (\text{C8})$$

From the last two equations, it follows

$$\begin{aligned}
T &= m(s\dot{\theta}^2 + g \sin \theta) \\
&= \frac{mg}{s} \left[\frac{2M}{m} D + 2R(1 - \cos \theta) + 3s \sin \theta \right] \\
&= \frac{2mgR}{s} \left[\frac{MD}{mR} + (1 - \cos \theta) + \frac{3}{2} \left(\frac{\ell}{R} - \theta \right) \sin \theta \right]
\end{aligned} \tag{C9}$$

where Eq. (C5) has been used to obtain the last equality.

We now introduce the function

$$f(\theta) = 1 - \cos \theta + \frac{3}{2} \left(\frac{\ell}{R} - \theta \right) \sin \theta \tag{C10}$$

From the fact $\ell = (L - D) \gg R$, we may write

$$f(\theta) \approx 1 + \frac{3}{2} \frac{\ell}{R} \sin \theta - \cos \theta = 1 + A \sin(\theta - \phi) \tag{C11}$$

where we have introduced

$$A = \sqrt{1 + \left(\frac{3}{2} \frac{\ell}{R} \right)^2}, \quad \phi = \tan^{-1} \left(\frac{2R}{3\ell} \right) \tag{C12}$$

From Eq. (C11), the minimum value of $f(\theta)$ is seen to be given by

$$f_{\min} = 1 - A = 1 - \sqrt{1 + \left(\frac{3}{2} \frac{\ell}{R} \right)^2} \tag{C13}$$

Since the tension T remains nonnegative as the particle swings around the rod, we have from Eq. (C9) the inequality

$$\frac{MD}{mR} + f_{\min} = \frac{M(L - \ell)}{mR} + 1 - \sqrt{1 + \left(\frac{3\ell}{2R} \right)^2} \geq 0 \tag{C14}$$

or

$$\left(\frac{ML}{mR} \right) + 1 \geq \left(\frac{M\ell}{mR} \right) + \sqrt{1 + \left(\frac{3\ell}{2R} \right)^2} \approx \left(\frac{M\ell}{mR} \right) + \left(\frac{3\ell}{2R} \right) \tag{C15}$$

From Eq. (C4), Eq. (C15) may be written as

$$\left(\frac{ML}{mR} \right) + 1 \geq \left(\frac{ML}{mR} + \frac{3L}{2R} \right) (1 - \alpha) \tag{C16}$$

Neglecting terms of the order (R/L) or higher, the last inequality leads to

$$\alpha \geq 1 - \frac{\left(\frac{ML}{mR} \right) + 1}{\left(\frac{ML}{mR} + \frac{3L}{2R} \right)} = \frac{\frac{3L}{2R} - 1}{\frac{ML}{mR} + \frac{3L}{2R}} = \frac{1 - \frac{2R}{3L}}{\frac{2M}{3m} + 1} \approx \frac{1}{1 + \frac{2M}{3m}} \tag{C17}$$

The critical value for the ratio D/L is therefore

$$\alpha_c = \frac{1}{1 + \frac{2M}{3m}} \tag{C18}$$

Marking Scheme

Theoretical Question 1 A Swing with a Falling Weight

Total Scores	Sub Scores	Marking Scheme for Answers to the Problem
Part A 4.3 pts.	(a) 0.5	Relation between $\dot{\theta}$ and \dot{s} . ($\dot{s} = -R\dot{\theta}$) <ul style="list-style-type: none"> ➤ 0.2 for $\dot{\theta} \propto \dot{s}$. ➤ 0.3 for proportionality constant ($-R$).
	(b) 0.5	Velocity of Q relative to O . ($\vec{v}_Q = R\dot{\theta}\hat{t}$) <ul style="list-style-type: none"> ➤ 0.2 for magnitude $R\dot{\theta}$. ➤ 0.3 for direction \hat{t}.
	(c) 0.7	Particle's velocity at P relative to Q . ($\vec{v}' = -s\dot{\theta}\hat{r} + \dot{s}\hat{t}$) <ul style="list-style-type: none"> ➤ 0.2+0.1 for magnitude and direction of \hat{r}-component. ➤ 0.3+0.1 for magnitude and direction of \hat{t}-component.
	(d) 0.7	Particle's velocity at P relative to O . ($\vec{v} = \vec{v}' + \vec{v}_Q = -s\dot{\theta}\hat{r}$) <ul style="list-style-type: none"> ➤ 0.3 for vector addition of \vec{v}' and \vec{v}_Q. ➤ 0.2+0.2 for magnitude and direction of \vec{v}.
	(e) 0.7	\hat{t} -component of particle's acceleration at P . <ul style="list-style-type: none"> ➤ 0.3 for relating \vec{a} or $\vec{a} \cdot \hat{t}$ to the velocity in a way that implies $\vec{a} \cdot \hat{t} = v^2/s$. ➤ 0.4 for $\vec{a} \cdot \hat{t} = -s\dot{\theta}^2$ (0.1 for minus sign.)
	(f) 0.5	Potential energy U . <ul style="list-style-type: none"> ➤ 0.2 for formula $U = -mgh$. ➤ 0.3 for $h = R(1 - \cos\theta) + s \sin\theta$ or U as a function of θ, s, and R.
	(g) 0.7	Speed at lowest point v_m . <ul style="list-style-type: none"> ➤ 0.2 for lowest point at $\theta = \pi/2$ or U equals minimum U_m. ➤ 0.2 for total mechanical energy $E = mv_m^2/2 + U_m = 0$. ➤ 0.3 for $v_m = \sqrt{-2U_m/m} = \sqrt{2g[R + (L - \pi R/2)]}$.
Part B 4.3 pts.	(h) 2.4	Particle's speed v_s when \overline{QP} is shortest. <ul style="list-style-type: none"> ➤ 0.4 for tension T becomes zero when \overline{QP} is shortest. ➤ 0.3 for equation of motion $-T + mg \sin\theta = m(-s\dot{\theta}^2)$. ➤ 0.3 for $E = 0 = m(s\dot{\theta})^2/2 - mg[R(1 - \cos\theta) + s \sin\theta]$. ➤ 0.4 for $\frac{3}{2}(\theta_s - \frac{L}{R}) = \tan \frac{\theta_s}{2}$. ➤ 0.5 for $\theta_s = 9\pi/8$. ➤ 0.3+0.2 for $v_s = \sqrt{4gR/3 \cos \pi/16} = 1.133\sqrt{gR}$

	(i) 1.9	<p>The speed v_H of the particle at its highest point.</p> <ul style="list-style-type: none"> ➤ 0.4 for particle undergoes projectile motion when $\theta \geq \theta_s$. ➤ 0.3 for angle of projection $\phi = (3\pi/2 - \theta_s)$. ➤ 0.3 for v_H is the y-component of its velocity at $\theta = \theta_s$. ➤ 0.4 for noting particle does not strike the surface of the rod. ➤ 0.3+0.2 for $v_H = \sqrt{4gR/3} \cos(\pi/16) \sin(\pi/8) = 0.4334\sqrt{gR}.$
Part C 3.4 pts	(j) 3.4	<p>The critical value α_c of the ratio D/L.</p> <ul style="list-style-type: none"> ➤ 0.4 for particle's energy $E' = MgD$ when the weight has stopped. ➤ 0.3 for $s = L - D - R\theta$. ➤ 0.3 for $E' = MgD = mv^2/2 - mg[R(1 - \cos\theta) + s \sin\theta]$. ➤ 0.3 for $-T + mg \sin\theta = m(-s\dot{\theta}^2)$. ➤ 0.3 for concluding T must not be negative. ➤ 0.6 for an inequality leading to the determination of the range of D/L. ➤ 0.6 for solving the inequality to give the range of $\alpha = D/L$. ➤ 0.6 for $\alpha_c = (1 + 2M/3m)$.

Solution to Theoretical Question 2

A Piezoelectric Crystal Resonator under an Alternating Voltage

Part A

- (a) Refer to Figure A1. The left face of the rod moves a distance $v\Delta t$ while the pressure wave travels a distance $u\Delta t$ with $u = \sqrt{Y/\rho}$. The strain at the left face is

$$S = \frac{\Delta\ell}{\ell} = \frac{-v\Delta t}{u\Delta t} = \frac{-v}{u} \quad (\text{A1a})$$

From Hooke's law, the pressure at the left face is

$$p = -YS = Y\frac{v}{u} = \rho uv \quad (\text{A1b})$$

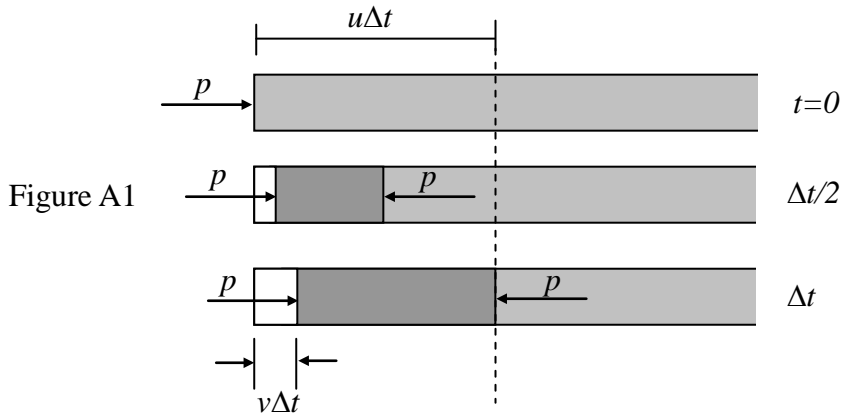

- (b) The velocity v is related to the displacement ξ as in a simple harmonic motion (or a uniform circular motion, as shown in Figure A2) of angular frequency $\omega = ku$. Therefore, if $\xi(x,t) = \xi_0 \sin k(x-ut)$, then

$$v(x,t) = -ku\xi_0 \cos k(x-ut). \quad (\text{A2})$$

The strain and pressure are related to velocity as in Problem (a). Hence,

$$S(x,t) = -v(x,t)/u = k\xi_0 \cos k(x-ut) \quad (\text{A3})$$

$$\begin{aligned} p(x,t) &= \rho uv(x,t) = -k\rho u^2 \xi_0 \cos k(x-ut) \\ &= -YS(x,t) = -kY\xi_0 \cos k(x-ut) \end{aligned} \quad (\text{A4})$$

Alternatively, the answers may be obtained by differentiations:

$$v(x,t) = \frac{\Delta\xi}{\Delta t} = -ku\xi_0 \cos k(x-ut),$$

$$S(x,t) = \frac{\Delta\xi}{\Delta x} = k\xi_0 \cos k(x-ut),$$

$$p(x,t) = -Y \frac{\Delta\xi}{\Delta x} = -kY\xi_0 \cos k(x-ut).$$

Figure A2

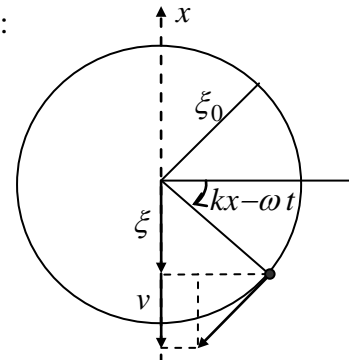

Part B

- (c) Since the angular frequency ω and speed of propagation u are given, the wavelength is given by $\lambda = 2\pi/k$ with $k = \omega/u$. The spatial variation of the displacement ξ is therefore described by

$$g(x) = B_1 \sin k\left(x - \frac{b}{2}\right) + B_2 \cos k\left(x - \frac{b}{2}\right) \quad (\text{B1})$$

Since the centers of the electrodes are assumed to be stationary, $g(b/2) = 0$. This leads to $B_2 = 0$. Given that the maximum of $g(x)$ is 1, we have $B_1 = \pm 1$ and

$$g(x) = \pm \sin \frac{\omega}{u}\left(x - \frac{b}{2}\right) \quad (\text{B2})$$

Thus, the displacement is

$$\xi(x, t) = \pm 2\xi_0 \sin \frac{\omega}{u}\left(x - \frac{b}{2}\right) \cos \omega t \quad (\text{B3})$$

- (d) Since the pressure p (or stress T) must vanish at the end faces of the quartz slab (i.e., $x = 0$ and $x = b$), the answer to this problem can be obtained, by analogy, from the resonant frequencies of sound waves in an open pipe of length b . However, given that the centers of the electrodes are stationary, all even harmonics of the fundamental tone must be excluded because they have antinodes, rather than nodes, of displacement at the bisection plane of the slab.

Since the fundamental tone has a wavelength $\lambda = 2b$, the fundamental frequency is given by $f_1 = u/(2b)$. The speed of propagation u is given by

$$u = \sqrt{\frac{Y}{\rho}} = \sqrt{\frac{7.87 \times 10^{10}}{2.65 \times 10^3}} = 5.45 \times 10^3 \text{ m/s} \quad (\text{B4})$$

and, given that $b = 1.00 \times 10^{-2}$ m, the two lowest standing wave frequencies are

$$f_1 = \frac{u}{2b} = 273 \text{ (kHz)}, \quad f_3 = 3f_1 = \frac{3u}{2b} = 818 \text{ (kHz)} \quad (\text{B5})$$

[Alternative solution to Problems (c) and (d)]:

A longitudinal standing wave in the quartz slab has a displacement node at $x = b/2$. It may be regarded as consisting of two waves traveling in opposite directions. Thus, its displacement and velocity must have the following form

$$\begin{aligned} \xi(x, t) &= \xi_m \left[\sin k\left(x - \frac{b}{2} - ut\right) + \sin k\left(x - \frac{b}{2} + ut\right) \right] \\ &= 2\xi_m \sin k\left(x - \frac{b}{2}\right) \cos \omega t \end{aligned} \quad (\text{B6})$$

$$\begin{aligned} v(x, t) &= -ku\xi_m \left[\cos k\left(x - \frac{b}{2} - ut\right) - \cos k\left(x - \frac{b}{2} + ut\right) \right] \\ &= -2\omega\xi_m \sin k\left(x - \frac{b}{2}\right) \sin \omega t \end{aligned} \quad (\text{B7})$$

where $\omega = ku$ and the first and second factors in the square brackets represent waves

traveling along the $+x$ and $-x$ directions, respectively. Note that Eq. (B6) is identical to Eq. (B3) if we set $\xi_m = \pm\xi_0$.

For a wave traveling along the $-x$ direction, the velocity v must be replaced by $-v$ in Eqs. (A1a) and (A1b) so that we have

$$S = \frac{-v}{u} \quad \text{and} \quad p = \rho uv \quad (\text{waves traveling along } +x) \quad (\text{B8})$$

$$S = \frac{v}{u} \quad \text{and} \quad p = -\rho uv \quad (\text{waves traveling along } -x) \quad (\text{B9})$$

As in Problem (b), the strain and pressure are therefore given by

$$\begin{aligned} S(x,t) &= -k\xi_m \left[-\cos k\left(x - \frac{b}{2} - ut\right) - \cos k\left(x - \frac{b}{2} + ut\right) \right] \\ &= 2k\xi_m \cos k\left(x - \frac{b}{2}\right) \cos \omega t \end{aligned} \quad (\text{B10})$$

$$\begin{aligned} p(x,t) &= -\rho u \omega \xi_m \left[\cos k\left(x - \frac{b}{2} - ut\right) + \cos k\left(x - \frac{b}{2} + ut\right) \right] \\ &= -2\rho u \omega \xi_m \cos k\left(x - \frac{b}{2}\right) \cos \omega t \end{aligned} \quad (\text{B11})$$

Note that v , S , and p may also be obtained by differentiating ξ as in Problem (b).

The stress T or pressure p must be zero at both ends ($x = 0$ and $x = b$) of the slab at all times because they are free. From Eq. (B11), this is possible only if $\cos(kb/2) = 0$ or

$$kb = \frac{\omega}{u} b = \frac{2\pi f}{\lambda f} b = n\pi, \quad n = 1, 3, 5, \dots \quad (\text{B12})$$

In terms of wavelength λ , Eq. (B12) may be written as

$$\lambda = \frac{2b}{n}, \quad n = 1, 3, 5, \dots \quad (\text{B13})$$

The frequency is given by

$$f = \frac{u}{\lambda} = \frac{nu}{2b} = \frac{n}{2b} \sqrt{\frac{Y}{\rho}}, \quad n = 1, 3, 5, \dots \quad (\text{B14})$$

This is identical with the results given in Eqs. (B4) and (B5).

(e) From Eqs. (5a) and (5b) in the Question, the piezoelectric effect leads to the equations

$$T = Y(S - d_p E) \quad (\text{B15})$$

$$\sigma = Yd_p S + \varepsilon_T \left(1 - Y \frac{d_p^2}{\varepsilon_T} \right) E \quad (\text{B16})$$

Because $x = b/2$ must be a node of displacement for any longitudinal standing wave in the slab, the displacement ξ and strain S must have the form given in Eqs. (B6) and (B10), i.e., with $\omega = ku$,

$$\xi(x,t) = \xi_m \sin k\left(x - \frac{b}{2}\right) \cos(\omega t + \phi) \quad (\text{B17})$$

$$S(x, t) = k\xi_m \cos k\left(x - \frac{b}{2}\right) \cos(\omega t + \phi) \quad (\text{B18})$$

where a phase constant ϕ is now included in the time-dependent factors.

By assumption, the electric field E between the electrodes is uniform and depends only on time:

$$E(x, t) = \frac{V(t)}{h} = \frac{V_m \cos \omega t}{h} \quad (\text{B19})$$

Substituting Eqs. (B18) and (B19) into Eq. (B15), we have

$$T = Y \left[k\xi_m \cos k\left(x - \frac{b}{2}\right) \cos(\omega t + \phi) - \frac{d_p}{h} V_m \cos \omega t \right] \quad (\text{B20})$$

The stress T must be zero at both ends ($x = 0$ and $x = b$) of the slab at all times because they are free. This is possible only if $\phi = 0$ and

$$k\xi_m \cos \frac{kb}{2} = d_p \frac{V_m}{h} \quad (\text{B21})$$

Since $\phi = 0$, Eqs. (B16), (B18), and (B19) imply that the surface charge density must have the same dependence on time t and may be expressed as

$$\sigma(x, t) = \sigma(x) \cos \omega t \quad (\text{B22})$$

with the dependence on x given by

$$\begin{aligned} \sigma(x) &= Y d_p k \xi_m \cos k\left(x - \frac{b}{2}\right) + \varepsilon_T \left(1 - Y \frac{d_p^2}{\varepsilon_T}\right) \frac{V_m}{h} \\ &= \left[Y \frac{d_p^2}{\cos \frac{kb}{2}} \cos k\left(x - \frac{b}{2}\right) + \varepsilon_T \left(1 - Y \frac{d_p^2}{\varepsilon_T}\right) \right] \frac{V_m}{h} \end{aligned} \quad (\text{B23})$$

- (f) At time t , the total surface charge $Q(t)$ on the lower electrode is obtained by integrating $\sigma(x, t)$ in Eq. (B22) over the surface of the electrode. The result is

$$\begin{aligned} \frac{Q(t)}{V(t)} &= \frac{1}{V(t)} \int_0^b \sigma(x, t) w dx = \frac{1}{V_m} \int_0^b \sigma(x) w dx \\ &= \frac{w}{h} \int_0^b \left[Y \frac{d_p^2}{\cos \frac{kb}{2}} \cos k\left(x - \frac{b}{2}\right) + \varepsilon_T \left(1 - Y \frac{d_p^2}{\varepsilon_T}\right) \right] dx \\ &= \left(\varepsilon_T \frac{bw}{h} \right) \left[Y \frac{d_p^2}{\varepsilon_T} \left(\frac{2}{kb} \tan \frac{kb}{2} \right) + \left(1 - Y \frac{d_p^2}{\varepsilon_T}\right) \right] \\ &= C_0 \left[\alpha^2 \left(\frac{2}{kb} \tan \frac{kb}{2} \right) + (1 - \alpha^2) \right] \end{aligned} \quad (\text{B24})$$

where

$$C_0 = \varepsilon_T \frac{bw}{h}, \quad \alpha^2 = Y \frac{d_p^2}{\varepsilon_T} = \frac{(2.25)^2 \times 10^{-2}}{1.27 \times 4.06} = 9.82 \times 10^{-3} \quad (\text{B25})$$

(The constant α is called the *electromechanical coupling coefficient*.)

Note: The result $C_0 = \varepsilon_T bw/h$ can readily be seen by considering the static limit $k = 0$ of Eq. (5) in the Question. Since $\tan x \approx x$ when $x \ll 1$, we have

$$\lim_{k \rightarrow 0} Q(t)/V(t) \approx C_0[\alpha^2 + (1 - \alpha^2)] = C_0 \quad (\text{B26})$$

Evidently, the constant C_0 is the capacitance of the parallel-plate capacitor formed by the electrodes (of area bw) with the quartz slab (of thickness h and permittivity ε_T) serving as the dielectric medium. It is therefore given by $\varepsilon_T bw/h$.

Marking Scheme

Theoretical Question 2

A Piezoelectric Crystal Resonator under an Alternating Voltage

Total Scores	Sub Scores	Marking Scheme for Answers to the Problem
Part A 4.0 pts.	(a) 1.6	<p>The strain S and pressure p on the left face.</p> <ul style="list-style-type: none"> ➤ 0.4 for $\Delta \ell = v\Delta t$ and $\ell = u\Delta t$. ➤ 0.4 for $S = -v/u$. (0.1 for sign) ➤ 0.4 for relating p to S as $p = -YS$. (0.1 for sign) ➤ 0.4 for $p = \rho uv$. (0.1 for sign)
	(b) 2.4	<p>The velocity $v(x, t)$, strain $S(x, t)$, and pressure $p(x, t)$.</p> <ul style="list-style-type: none"> ➤ 0.3×3 sinusoidal variation with correct phase constant. (0.2 for phase constant.) ➤ 0.3×3 for amplitude. ➤ 0.2×3 for dependence on x and t as $(kx - kt)$.
Part B 6.0 pts	(c) 1.2	<p>The function $g(x)$ for a standing wave of angular frequency ω.</p> <ul style="list-style-type: none"> ➤ 0.4 for $g(b/2) = 0$. ➤ 0.3+0.1 for $B_1 = \pm 1$ (0.1 for both signs) ➤ 0.4 for $B_2 = 0$
	(d) 1.2	<p>The two lowest standing wave frequencies.</p> <ul style="list-style-type: none"> ➤ 0.2 for wavelength of fundamental tone $\lambda = 2b$. ➤ 0.2 for excluding even harmonics. ➤ (0.3+0.1) for $f_1 = u/2b = 273$ kHz. (0.1 for value) ➤ (0.3+0.1) for $f_3 = 3u/2b = 818$ kHz. (0.1 for value)
	(e) 2.2	<p>The surface charge density σ as a function of x and t.</p> <ul style="list-style-type: none"> ➤ 0.1×2 for ξ and S, each a separable function of x and t. ➤ 0.1×2 for ξ and S, each depends on time as $\cos \omega t$ with $\phi = 0$. ➤ 0.3 for spatial part $\xi(x) = \xi_m \sin k(x - b/2)$. ➤ 0.3 for spatial part $S(x) = k\xi_m \cos k(x - b/2)$. ➤ 0.3 for $T(x) = [k\xi_m \cos k(x - b/2) - d_p V_m / h]Y$. ➤ 0.3 for $k\xi_m \cos(kb/2) = d_p V_m / h$. ➤ 0.6 for D_1 (0.3) and D_2 (0.3) in $\sigma(x)$.
	(f) 1.4	<p>The constants C_0 and α^2.</p> <ul style="list-style-type: none"> ➤ 0.2 for relation between σ and Q as $Q(t) = \left(\int_0^b \sigma(x) w dx \right) \cos \omega t.$ ➤ 0.3 for noting $Q(t)/V(t) \approx C_0$ as $k \rightarrow 0$. ➤ 0.4 for $C_0 = \epsilon_T bw / h$. ➤ 0.4+0.1 for $\alpha^2 = Yd_p^2 / \epsilon_T = 9.82 \times 10^{-3}$. (0.1 for value)

Solution to Theoretical Question 3

Part A

Neutrino Mass and Neutron Decay

(a) Let $(c^2E_e, c\vec{q}_e)$, $(c^2E_p, c\vec{q}_p)$, and $(c^2E_\nu, c\vec{q}_\nu)$ be the energy-momentum 4-vectors of the electron, the proton, and the anti-neutrino, respectively, in the rest frame of the neutron. Notice that $E_e, E_p, E_\nu, \vec{q}_e, \vec{q}_p, \vec{q}_\nu$ are all in units of mass. The proton and the anti-neutrino may be considered as forming a system of total rest mass M_c , total energy c^2E_c , and total momentum $c\vec{q}_c$. Thus, we have

$$E_c = E_p + E_\nu, \quad \vec{q}_c = \vec{q}_p + \vec{q}_\nu, \quad M_c^2 = E_c^2 - q_c^2 \quad (\text{A1})$$

Note that the magnitude of the vector \vec{q}_c is denoted as q_c . The same convention also applies to all other vectors.

Since energy and momentum are conserved in the neutron decay, we have

$$E_c + E_e = m_n \quad (\text{A2})$$

$$\vec{q}_c = -\vec{q}_e \quad (\text{A3})$$

When squared, the last equation leads to the following equality

$$q_c^2 = q_e^2 = E_e^2 - m_e^2 \quad (\text{A4})$$

From Eq. (A4) and the third equality of Eq. (A1), we obtain

$$E_c^2 - M_c^2 = E_e^2 - m_e^2 \quad (\text{A5})$$

With its second and third terms moved to the other side of the equality, Eq. (A5) may be divided by Eq. (A2) to give

$$E_c - E_e = \frac{1}{m_n}(M_c^2 - m_e^2) \quad (\text{A6})$$

As a system of coupled linear equations, Eqs. (A2) and (A6) may be solved to give

$$E_c = \frac{1}{2m_n}(m_n^2 - m_e^2 + M_c^2) \quad (\text{A7})$$

$$E_e = \frac{1}{2m_n}(m_n^2 + m_e^2 - M_c^2) \quad (\text{A8})$$

Using Eq. (A8), the last equality in Eq. (A4) may be rewritten as

$$\begin{aligned} q_e &= \frac{1}{2m_n} \sqrt{(m_n^2 + m_e^2 - M_c^2)^2 - (2m_n m_e)^2} \\ &= \frac{1}{2m_n} \sqrt{(m_n + m_e + M_c)(m_n + m_e - M_c)(m_n - m_e + M_c)(m_n - m_e - M_c)} \end{aligned} \quad (\text{A9})$$

Eq. (A8) shows that a maximum of E_e corresponds to a minimum of M_c^2 . Now the rest mass M_c is the total energy of the proton and anti-neutrino pair in their center of mass (or momentum) frame so that it achieves the minimum

$$(M_c)_{\min} = M = m_p + m_\nu \quad (\text{A10})$$

when the proton and the anti-neutrino are both at rest in the center of mass frame. Hence, from Eqs. (A8) and (A10), the maximum energy of the electron $E = c^2 E_e$ is

$$E_{\max} = \frac{c^2}{2m_n} \left[m_n^2 + m_e^2 - (m_p + m_\nu)^2 \right] \approx 1.292569 \text{ MeV} \approx 1.29 \text{ MeV} \quad (\text{A11})$$

When Eq. (A10) holds, the proton and the anti-neutrino move with the same velocity v_m of the center of mass and we have

$$\frac{v_m}{c} = \left(\frac{q_\nu}{E_\nu} \right)_{E=E_{\max}} = \left(\frac{q_p}{E_p} \right)_{E=E_{\max}} = \left(\frac{q_c}{E_c} \right)_{E=E_{\max}} = \left(\frac{q_e}{E_c} \right)_{M_c=m_p+m_\nu} \quad (\text{A12})$$

where the last equality follows from Eq. (A3). By Eqs. (A7) and (A9), the last expression in Eq. (A12) may be used to obtain the speed of the anti-neutrino when $E = E_{\max}$. Thus, with $M = m_p + m_\nu$, we have

$$\begin{aligned} \frac{v_m}{c} &= \frac{\sqrt{(m_n + m_e + M)(m_n + m_e - M)(m_n - m_e + M)(m_n - m_e - M)}}{m_n^2 - m_e^2 + M^2} \\ &\approx 0.00126538 \approx 0.00127 \end{aligned} \quad (\text{A13})$$

[Alternative Solution]

Assume that, in the rest frame of the neutron, the electron comes out with momentum $c\vec{q}_e$ and energy $c^2 E_e$, the proton with $c\vec{q}_p$ and $c^2 E_p$, and the anti-neutrino with $c\vec{q}_\nu$ and $c^2 E_\nu$. With the magnitude of vector \vec{q}_α denoted by the symbol q_α , we have

$$E_p^2 = m_p^2 + q_p^2, \quad E_\nu^2 = m_\nu^2 + q_\nu^2, \quad E_e^2 = m_e^2 + q_e^2 \quad (\text{1A})$$

Conservation of energy and momentum in the neutron decay leads to

$$E_p + E_\nu = m_n - E_e \quad (\text{2A})$$

$$\vec{q}_p + \vec{q}_\nu = -\vec{q}_e \quad (\text{3A})$$

When squared, the last two equations lead to

$$E_p^2 + E_\nu^2 + 2E_p E_\nu = (m_n - E_e)^2 \quad (\text{4A})$$

$$q_p^2 + q_\nu^2 + 2\vec{q}_p \cdot \vec{q}_\nu = q_e^2 = E_e^2 - m_e^2 \quad (\text{5A})$$

Subtracting Eq. (5A) from Eq. (4A) and making use of Eq. (1A) then gives

$$m_p^2 + m_\nu^2 + 2(E_p E_\nu - \vec{q}_p \cdot \vec{q}_\nu) = m_n^2 + m_e^2 - 2m_n E_e \quad (\text{6A})$$

or, equivalently,

$$2m_n E_e = m_n^2 + m_e^2 - m_p^2 - m_\nu^2 - 2(E_p E_\nu - \bar{q}_p \cdot \bar{q}_\nu) \quad (7A)$$

If θ is the angle between \bar{q}_p and \bar{q}_ν , we have $\bar{q}_p \cdot \bar{q}_\nu = q_p q_\nu \cos \theta \leq q_p q_\nu$ so that Eq. (7A) leads to the relation

$$2m_n E_e \leq m_n^2 + m_e^2 - m_p^2 - m_\nu^2 - 2(E_p E_\nu - q_p q_\nu) \quad (8A)$$

Note that the equality in Eq. (8A) holds only if $\theta = 0$, i.e., the energy of the electron $c^2 E_e$ takes on its maximum value only when the anti-neutrino and the proton *move in the same direction*.

Let the speeds of the proton and the anti-neutrino in the rest frame of the neutron be $c\beta_p$ and $c\beta_\nu$, respectively. We then have $q_p = \beta_p E_p$ and $q_\nu = \beta_\nu E_\nu$. As shown in Fig. A1, we introduce the angle ϕ_ν ($0 \leq \phi_\nu < \pi/2$) for the antineutrino by

$$q_\nu = m_\nu \tan \phi_\nu, \quad E_\nu = \sqrt{m_\nu^2 + q_\nu^2} = m_\nu \sec \phi_\nu, \quad \beta_\nu = q_\nu / E_\nu = \sin \phi_\nu \quad (9A)$$

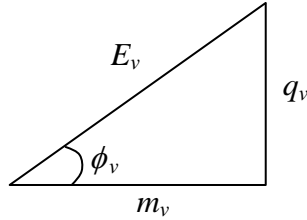

Figure A1

Similarly, for the proton, we write, with $0 \leq \phi_p < \pi/2$,

$$q_p = m_p \tan \phi_p, \quad E_p = \sqrt{m_p^2 + q_p^2} = m_p \sec \phi_p, \quad \beta_p = q_p / E_p = \sin \phi_p \quad (10A)$$

Eq. (8A) may then be expressed as

$$2m_n E_e \leq m_n^2 + m_e^2 - m_p^2 - m_\nu^2 - 2m_p m_\nu \left(\frac{1 - \sin \phi_p \sin \phi_\nu}{\cos \phi_p \cos \phi_\nu} \right) \quad (11A)$$

The factor in parentheses at the end of the last equation may be expressed as

$$\frac{1 - \sin \phi_p \sin \phi_\nu}{\cos \phi_p \cos \phi_\nu} = \frac{1 - \sin \phi_p \sin \phi_\nu - \cos \phi_p \cos \phi_\nu}{\cos \phi_p \cos \phi_\nu} + 1 = \frac{1 - \cos(\phi_p - \phi_\nu)}{\cos \phi_p \cos \phi_\nu} + 1 \geq 1 \quad (12A)$$

and clearly assumes its minimum possible value of 1 when $\phi_p = \phi_\nu$, i.e., when the anti-neutrino and the proton *move with the same velocity* so that $\beta_p = \beta_\nu$. Thus, it follows from Eq. (11A) that the maximum value of E_e is

$$\begin{aligned} (E_e)_{\max} &= \frac{1}{2m_n} (m_n^2 + m_e^2 - m_p^2 - m_\nu^2 - 2m_p m_\nu) \\ &= \frac{1}{2m_n} [m_n^2 + m_e^2 - (m_p + m_\nu)^2] \end{aligned} \quad (13A)$$

and the maximum energy of the electron $E = c^2 E_e$ is

$$E_{\max} = c^2 (E_e)_{\max} \approx 1.292569 \text{ MeV} \approx 1.29 \text{ MeV} \quad (14A)$$

When the anti-neutrino and the proton move with the same velocity, we have, from Eqs. (9A), (10A), (2A), (3A), and (1A), the result

$$\beta_v = \beta_p = \frac{q_p}{E_p} = \frac{q_v}{E_v} = \frac{q_p + q_v}{E_p + E_v} = \frac{q_e}{m_n - E_e} = \frac{\sqrt{E_e^2 - m_e^2}}{m_n - E_e} \quad (15A)$$

Substituting the result of Eq. (13A) into the last equation, the speed v_m of the anti-neutrino when the electron attains its maximum value E_{\max} is, with $M = m_p + m_v$, given by

$$\begin{aligned} \frac{v_m}{c} &= (\beta_v)_{\max E_e} = \frac{\sqrt{(E_e)_{\max}^2 - m_e^2}}{m_n - (E_e)_{\max}} = \frac{\sqrt{(m_n^2 + m_e^2 - M^2)^2 - 4m_n^2 m_e^2}}{2m_n^2 - (m_n^2 + m_e^2 - M^2)} \\ &= \frac{\sqrt{(m_n + m_e + M)(m_n + m_e - M)(m_n - m_e + M)(m_n - m_e - M)}}{m_n^2 - m_e^2 + M^2} \\ &\approx 0.00126538 \approx 0.00127 \end{aligned} \quad (16A)$$

Part B

Light Levitation

(b) Refer to Fig. B1. Refraction of light at the spherical surface obeys Snell's law and leads to

$$n \sin \theta_i = \sin \theta_t \quad (B1)$$

Neglecting terms of the order $(\delta/R)^3$ or higher in sine functions, Eq. (B1) becomes

$$n\theta_i \approx \theta_t \quad (B2)$$

For the triangle $\triangle FAC$ in Fig. B1, we have

$$\beta = \theta_t - \theta_i \approx n\theta_i - \theta_i = (n-1)\theta_i \quad (B3)$$

Let f_0 be the frequency of the incident light. If n_p is the number of photons incident on the plane surface per unit area per unit time, then the total number of photons incident on the plane surface per unit time is $n_p \pi \delta^2$. The total power P of photons incident on the plane surface is $(n_p \pi \delta^2)(hf_0)$, with h being Planck's constant. Hence,

$$n_p = \frac{P}{\pi \delta^2 h f_0} \quad (B4)$$

The number of photons incident on an annular disk of inner radius r and outer radius $r + dr$ on the plane surface per unit time is $n_p (2\pi r dr)$, where $r = R \tan \theta_i \approx R \theta_i$.

Therefore,

$$n_p (2\pi r dr) \approx n_p (2\pi R^2) \theta_i d\theta_i \quad (B5)$$

The z -component of the momentum carried away per unit time by these photons when

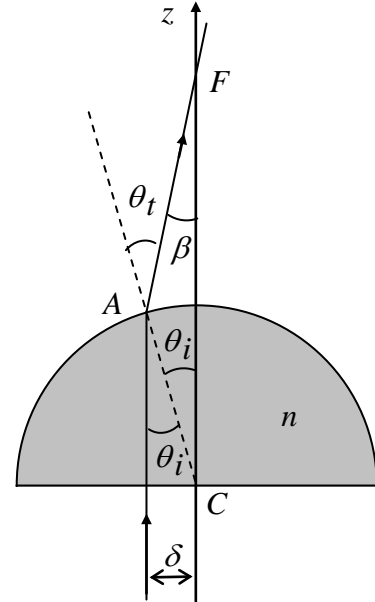

Fig. B1

refracted at the spherical surface is

$$\begin{aligned}
dF_z &= n_p \frac{hf_o}{c} (2\pi r dr) \cos \beta \approx n_p \frac{hf_o}{c} (2\pi R^2) \left(1 - \frac{\beta^2}{2}\right) \theta_i d\theta_i \\
&\approx n_p \frac{hf_o}{c} (2\pi R^2) \left[\theta_i - \frac{(n-1)^2}{2} \theta_i^3 \right] d\theta_i
\end{aligned} \tag{B6}$$

so that the z -component of the total momentum carried away per unit time is

$$\begin{aligned}
F_z &= 2\pi R^2 n_p \left(\frac{hf_o}{c} \right) \int_0^{\theta_{im}} \left[\theta_i - \frac{(n-1)^2}{2} \theta_i^3 \right] d\theta_i \\
&= \pi R^2 n_p \left(\frac{hf_o}{c} \right) \theta_{im}^2 \left[1 - \frac{(n-1)^2}{4} \theta_{im}^2 \right]
\end{aligned} \tag{B7}$$

where $\tan \theta_{im} = \frac{\delta}{R} \approx \theta_{im}$. Therefore, by the result of Eq. (B5), we have

$$F_z = \frac{\pi R^2 P}{\pi \delta^2 hf_o} \left(\frac{hf_o}{c} \right) \frac{\delta^2}{R^2} \left[1 - \frac{(n-1)^2 \delta^2}{4R^2} \right] = \frac{P}{c} \left[1 - \frac{(n-1)^2 \delta^2}{4R^2} \right] \tag{B8}$$

The force of optical levitation is equal to the sum of the z -components of the forces exerted by the incident and refracted lights on the glass hemisphere and is given by

$$\frac{P}{c} + (-F_z) = \frac{P}{c} - \frac{P}{c} \left[1 - \frac{(n-1)^2 \delta^2}{4R^2} \right] = \frac{(n-1)^2 \delta^2}{4R^2} \frac{P}{c} \tag{B9}$$

Equating this to the weight mg of the glass hemisphere, we obtain the minimum laser power required to levitate the hemisphere as

$$P = \frac{4mgcR^2}{(n-1)^2 \delta^2} \tag{B10}$$

Marking Scheme

Theoretical Question 3 Neutrino Mass and Neutron Decay

Total Scores	Sub Scores	Marking Scheme for Answers to the Problem
Part A 4.0 pts.	(a) 4.0	<p>The maximum energy of the electron and the corresponding speed of the anti-neutrino.</p> <ul style="list-style-type: none"> ➤ 0.5 use energy-momentum conservation and can convert it into equations. ➤ 0.5 obtain an expression for E_e that allows the determination of its maximum value. ➤ (0.5+0.2) for concluding that proton and anti-neutrino must move with the same velocity when E_e is maximum. (0.2 for the same direction) ➤ 0.6 for establishing the minimum value of $(E_p E_v - \vec{q}_p \cdot \vec{q}_v)$ to be $m_p m_v$ or a conclusion equivalent to it. ➤ (0.5+0.1) for expression and value of E_{\max}. ➤ 0.5 for concluding $\beta_v = \sqrt{E_e^2 - m_e^2} / (m_n - E_e)$. ➤ (0.5+0.1) for expression and value of v_m/c.

Light Levitation

Part B 4.0 pts	(b) 4.0	<p>Laser power needed to balance the weight of the glass hemisphere.</p> <ul style="list-style-type: none"> ➤ 0.3 for law of refraction $n \sin \theta_i = \sin \theta_t$. ➤ 0.3 for making the linear approximation $n \theta_i \approx \theta_t$. ➤ 0.4 for relation between angles of deviation and incidence. ➤ 0.3 for photon energy $\varepsilon = h\nu$. ➤ 0.3 for photon momentum $p = \varepsilon/c$. ➤ 0.3 for momentum of incident photons per unit time = P/c. ➤ 0.6 for momentum of photons refracted per unit time as a function of the angle of incidence. ➤ 0.4 for total momentum of photons refracted per unit time = $[1-(n-1)^2 \delta^2 / (4R^2)] P/c$. ➤ 0.4 for force of levitation = sum of forces exerted by incident and refracted photons. ➤ 0.4 for force of levitation = $(n-1)^2 \delta^2 P / (4cR^2)$. ➤ 0.3 for the needed laser power $P = 4mgcR^2 / (n-1)^2 \delta^2$.
-----------------------	----------------	---

Solutions to Experimental Problems

Part A: Optical Properties of Laser Diode

Question A-(1) (Total 1.5 point)

Measure, tabulate, and plot the J vs. I curve.

a. Data (0.3 pts.) : Proper data table marked with variables and units.

Table A-(1): Data for J vs. I .

I (mA)	9.2	15.2	19.5	21.6	22.2	22.7	23.0	23.4	23.8
J (V)	0.00	0.01	0.02	0.03	0.05	0.06	0.09	0.12	0.30
I (mA)	24.2	24.6	25.0	25.4	25.8	26.2	26.6	27.0	27.4
J (V)	0.66	1.02	1.41	1.88	2.23	2.64	3.04	3.36	3.78
I (mA)	27.8	28.2	28.6	29.0	29.4	29.8	30.2	30.5	31.0
J (V)	4.12	4.48	4.79	5.13	5.44	5.72	6.05	6.25	6.55
I (mA)	31.4	31.8	32.2	32.6	33.0	33.4	33.8	34.2	34.6
J (V)	6.75	6.99	7.22	7.40	7.60	7.78	7.93	8.07	8.14
I (mA)	35.0	35.5	36.0	36.5	37.0	37.6	38.0	38.6	
J (V)	8.18	8.20	8.22	8.24	8.24	8.25	8.26	8.27	

Current error : ± 0.1 mA; Voltage error : ± 0.01 V

- b. Plotting (0.3 pts.): Proper sizes of scales, and units for abscissa and ordinate that bear relation to the accuracy and range of the experiment.
- c. Curve (0.9 pts.): Proper data and adequate line shape
- As shown in Fig. A-1. Start $\sim 0 \rightarrow$ Threshold \rightarrow Linear \rightarrow Saturate.

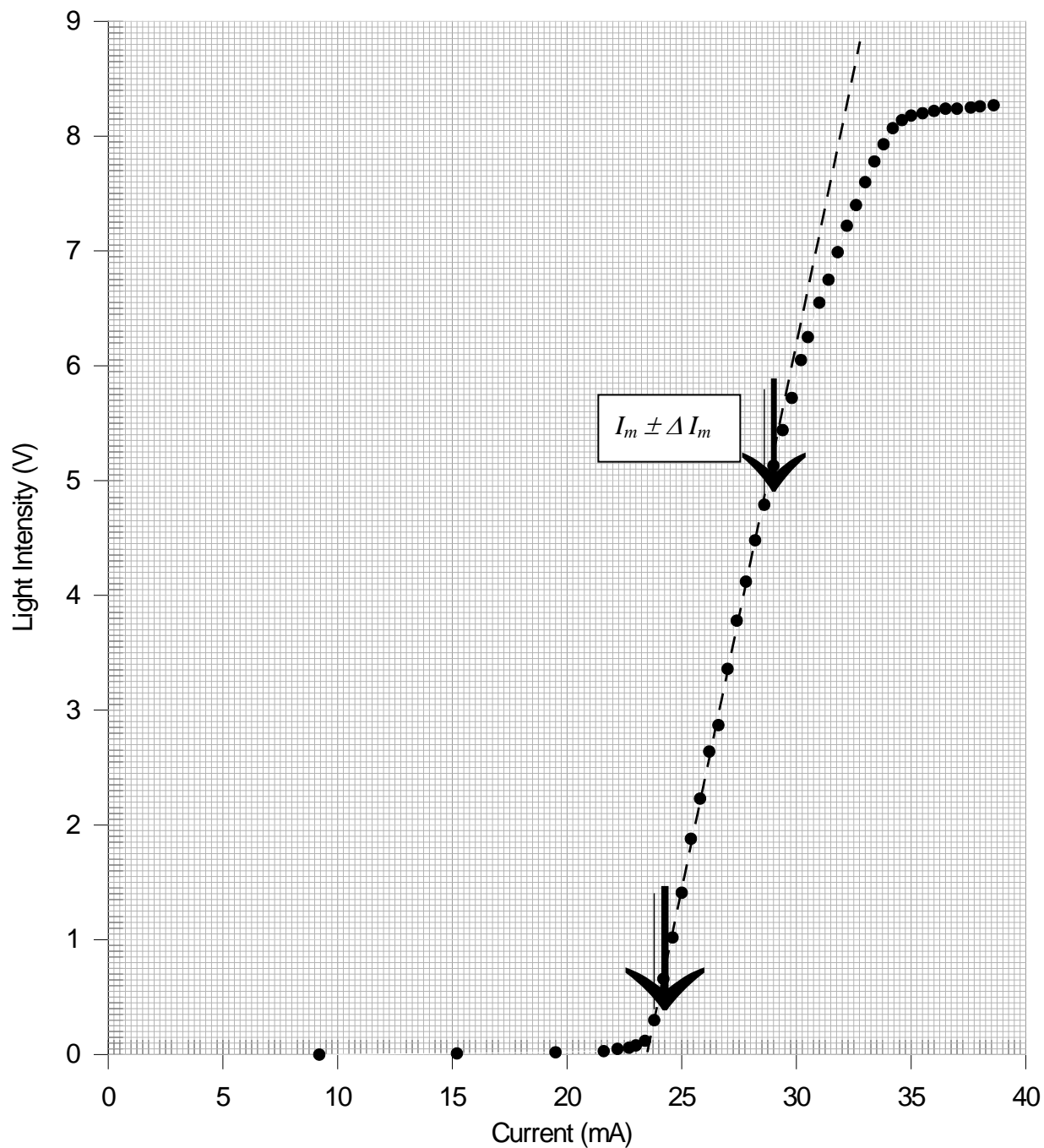

Fig. A-1 Graph of light intensity j versus current I

Question A-(2) (Total 3.5 points)

Estimate the maximum current I_m with uncertainty in the linear region of the $\mathcal{J} - I$. Mark the linear region on the $\mathcal{J} - I$ curve figure by using arrows (\downarrow) and determine the threshold current I_{th} with detailed error analysis.

- Linear region marking (0.5 pts.) in Fig. A-1.
- Least-square method or eye-balling with ruler and error analysis (1.5 pt.)

Least-square fitting	Eye-balling with ruler
Error bar in graph 0.0x mA (0.5 pts)	Error bar in graph 0.x mA (0.5 pts)
Least-square method (0.5 pts)	Expanded scale graph (0.5 pts)
Error analysis (0.5 pts)	draw three lines for error analysis(0.5 pts)

- $I_m \pm \Delta I_m$ (0.5 pts.): Adequate value of I_m (0.3 pts.) and error($\pm \Delta I_m$) (0.2 pts.) from the linear region of \mathcal{J} -I curve.
- Adequate value of I_{th} with error (1.0 pts.)

$$I_{th} = (21 \sim 26) \pm (0.01 \text{ or } 0.2 \text{ for single value}) \text{ mA}$$

Adequate value of I_{th} (0.5 pts.) and error ($\pm \Delta I_{th}$) (0.5 pts.)

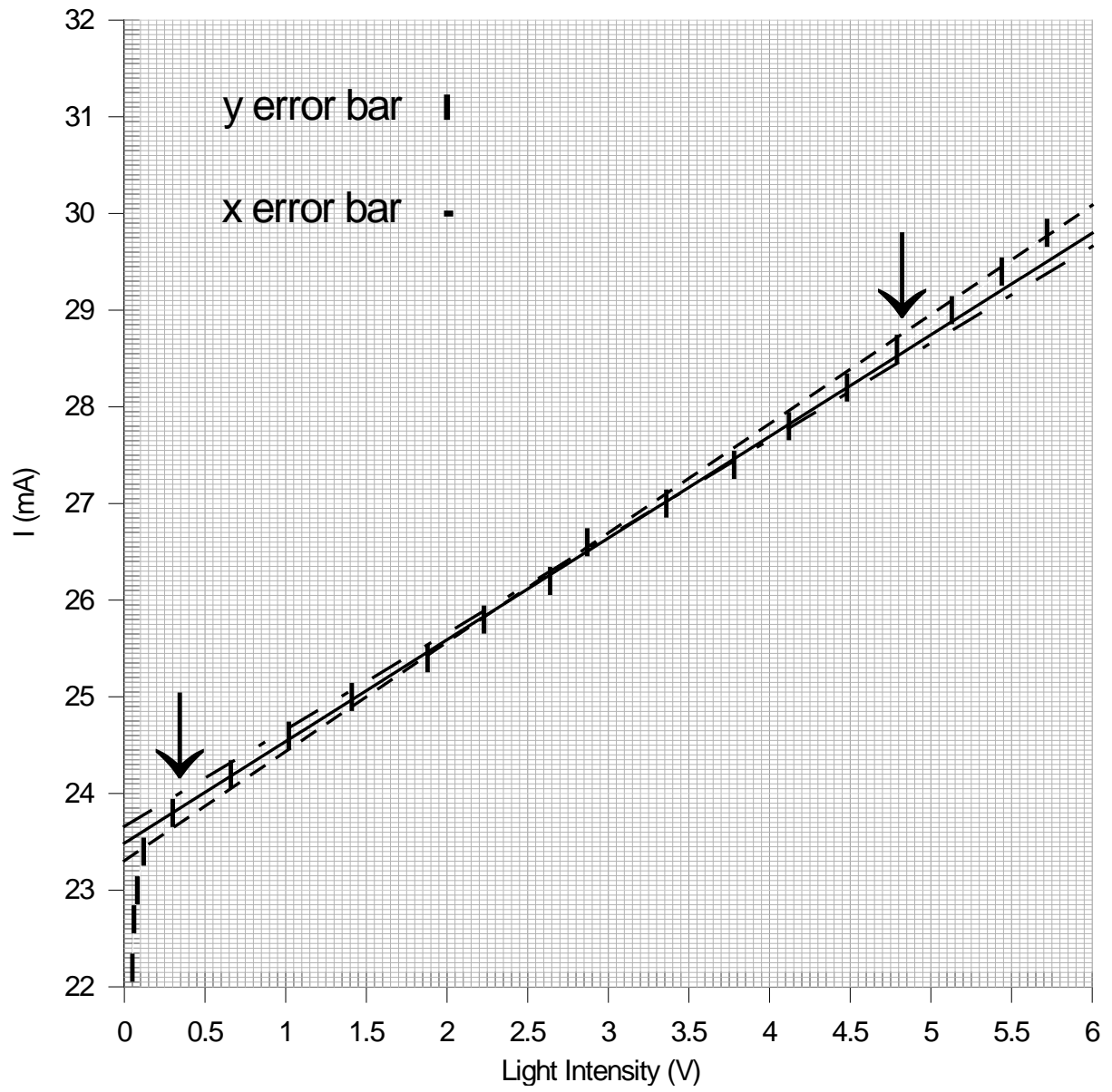

Fig. A-2 Straight lines and extrapolations

Appendix :

©A1-1

• Least-Square Method :

$$I = mJ + b \rightarrow b = I_{th}$$

For $y = mx + b$

	y: I(mA)	x: J	xy	x^2	$y(x) = mx+b$	$(y-y(x))^2$
1	23.8	0.30	7.14	0.090	23.7937	3.969E-05
2	24.2	0.66	15.972	0.4356	24.17134	0.000821
3	24.6	1.02	25.092	1.0404	24.54898	0.00260
4	25.0	1.41	35.25	1.9881	24.95809	0.00176
5	25.4	1.88	47.752	3.5344	25.45112	0.00261
6	25.8	2.23	57.534	4.9729	25.81827	0.000334
7	26.2	2.64	69.168	6.9696	26.24836	0.00234
8	26.6	3.04	80.864	9.2416	26.66796	0.00462
9	27.0	3.36	90.72	11.2896	27.00364	1.325E-05
10	27.4	3.78	103.572	14.2884	27.44422	0.00196
11	27.8	4.12	114.536	16.9744	27.80088	7.744E-07
12	28.2	4.48	126.336	20.0704	28.17852	0.000461
13	28.6	4.79	136.994	22.9441	28.50371	0.00927
	$\Sigma y =$ 340.6	$\Sigma x =$ 33.71	$\Sigma xy =$ 910.93	$\Sigma x^2 =$ 113.840		$\Sigma (y-y(x))^2 =$ 0.0268

$$\Delta = N\Sigma x^2 - (\Sigma x)^2 = 13(113.840) - (33.71)^2 = 343.556$$

$$m = \frac{1}{\Delta} (N\Sigma xy - \Sigma x \Sigma y) = \frac{13(910.93) - (33.71)(340.6)}{343.556} = 1.049$$

$$b = \frac{1}{\Delta} (\Sigma x^2 \Sigma y - \Sigma x \Sigma xy) = \frac{(113.840)(340.6) - (33.71)(910.93)}{343.556} = 23.479$$

$$\sigma_y = \sqrt{\frac{\sum(y - y(x))^2}{N - 2}} = \sqrt{\frac{0.0268}{13 - 2}} = 0.049$$

$$\sigma = \sqrt{(\sigma_y)^2 + \left(\frac{dy}{dx}\sigma_x\right)^2} = \sqrt{(0.049)^2 + (1.049 \times 0.005)^2} = 0.049$$

$$\sigma_m = \sqrt{\frac{N\sigma^2}{\Delta}} = \sqrt{\frac{13 \times 0.049^2}{343.556}} = 0.0095$$

$$\sigma_b = \sqrt{\frac{\sigma^2}{\Delta} \sum x^2} = 0.049 \times \sqrt{\frac{113.840}{343.556}} = 0.028$$

$$I_{th} = 23.48 \pm 0.03 \text{ mA}$$

©A1-2

• Eye-balling Method :

$$I = mJ + b \rightarrow b = I_{th}$$

For $y = mx + b$

$$\text{Line 1: } y = 1.00 x + 23.66$$

$$\text{Line 2: } y = 1.05 x + 23.48$$

$$\text{Line 3: } y = 1.13 x + 23.31$$

$$I_{th(av.)} = 23.48$$

$$I_{th(std.)} = 0.18$$

$$I_{th} = 23.5 \pm 0.2 \text{ mA}$$

Part B: Optical Properties of Nematic Liquid Crystal

Electro-optical switching characteristic of 90° TN LC cell

Question B-(1) (5.0 points)

Measure, tabulate, and plot the electro-optical switching curve (I vs. V_{rms} curve) of the NB 90° TN LC, and find its switching slope γ , where γ is defined as $(V_{90} - V_{10})/V_{10}$.

a. Proper data table marked with variables and units. (0.3 pts)

Applied voltage (Volts)	Light intensity (Volts)	Applied voltage (Volts)	Light intensity (Volts)
0.00	0.00	2.44	1.22
0.10	0.00	2.50	1.26
0.20	0.00	2.55	1.27
0.30	0.00	2.60	1.29
0.40	0.00	2.67	1.32
0.50	0.00	2.72	1.33
0.60	0.00	2.85	1.36
0.70	0.00	2.97	1.37
0.80	0.00	3.11	1.38
0.90	0.00	3.20	1.39
1.00	0.00	3.32	1.39
1.10	0.02	3.41	1.39
1.20	0.04	3.50	1.40
1.24	0.04	3.60	1.39
1.30	0.04	3.70	1.40
1.34	0.03	3.80	1.40
1.38	0.02	4.03	1.40
1.45	0.01	4.22	1.40
1.48	0.01	4.40	1.39
1.55	0.02	4.61	1.39
1.59	0.03	4.78	1.40
1.64	0.05	5.03	1.39
1.71	0.11	5.20	1.39
1.78	0.21	5.39	1.38
1.81	0.26	5.61	1.39
1.85	0.33	5.81	1.38
1.90	0.44	6.02	1.38
1.96	0.57	6.21	1.38
2.03	0.70	6.40	1.38
2.08	0.80	6.63	1.38
2.15	0.92	6.80	1.38
2.21	1.02	7.02	1.38
2.28	1.10	7.20	1.38
2.33	1.14		
2.39	1.19		

- b. Properly choose the size of scales and units for abscissa and ordinate that bears the relation to the accuracy and range of the experiment. (0.3 pts)
- c. Correct measurement of the light intensity (\mathcal{J}) as a function of the applied voltage (V_{rms}) and adequate $\mathcal{J} - V_{\text{rms}}$ curve plot.
- The intensity of the transmission light is smaller than 0.05 Volts in the normally black mode. (0.4 pts)
 - There is a small optical bounce before the external applied voltage reaches the critical voltage. (0.8 pts)
 - The intensity of the transmission light increases rapidly and abruptly when the external applied voltage exceeds the critical voltage. (0.4 pts)
 - The intensity of the transmission light displays the plateau behavior as the external applied voltage exceeds 3.0 Volts. (0.4 pts)

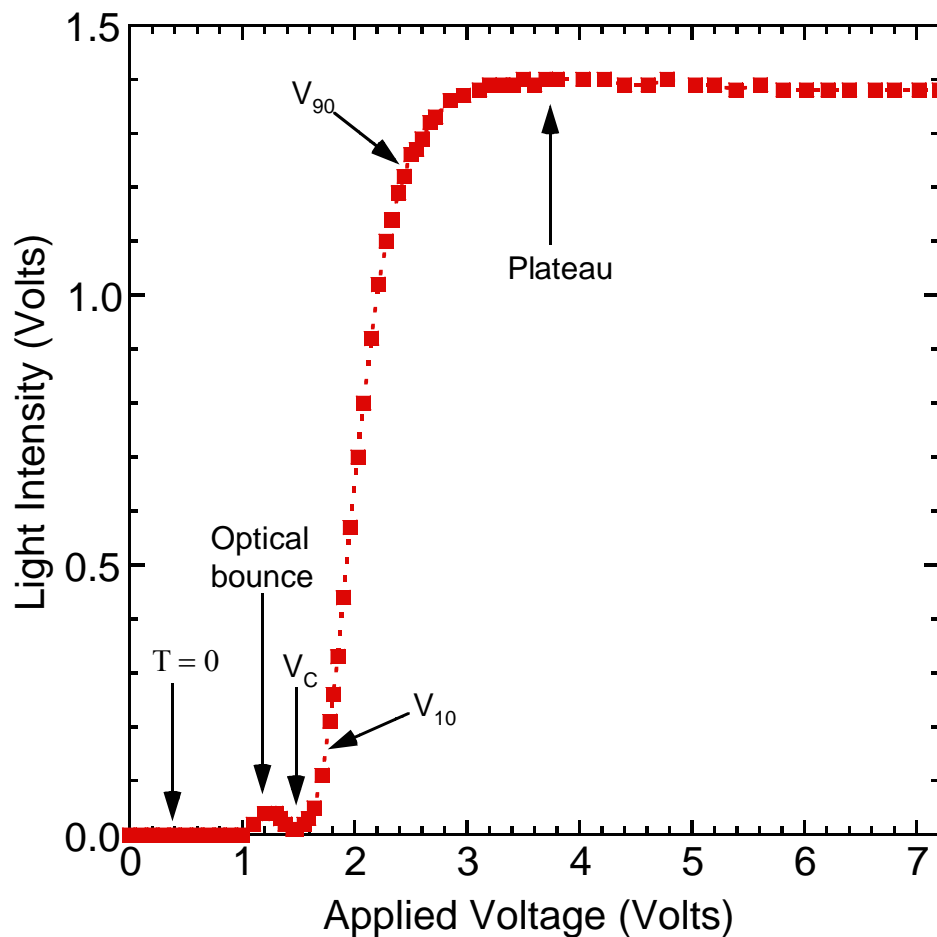

- d. Adequate value of γ with error.
- Find the maximum value of the light intensity in the region of the applied voltage between 3.0 and 7.2 Volts (0.6 pts)
 - Determine the value of 90 % of the maximum light intensity. Obtain the value of the applied voltage V_{90} by interpolation. (0.6 pts)

- Determine the value of 10 % of the maximum light intensity. Obtain the value of the applied voltage V_{10} by interpolation. (0.6 pts)
- Correct $\gamma \pm \Delta\gamma$ value, $(0.42 \sim 0.44) \pm 0.02$. (0.4+0.2 pts)

Question B-(2) (Total 2.5 points)

Determine the critical voltage V_c of this NB 90° TN LC cell. Show explicitly with graph how you determine the value V_c .

- a. Adequate value of V_c with error, $V_c \pm \Delta V_c$.
- Make the expanded scale plot and take more data points in the region of V_c . (0.8 pts)
 - Determine the value of V_c when the intensity of the transmission light increases rapidly and abruptly. (0.7 pts)
 - Correct $V_c \pm \Delta V_c$ value, $(1.20 \sim 1.50) \pm 0.01$ Volts. (0.8+0.2 pts)

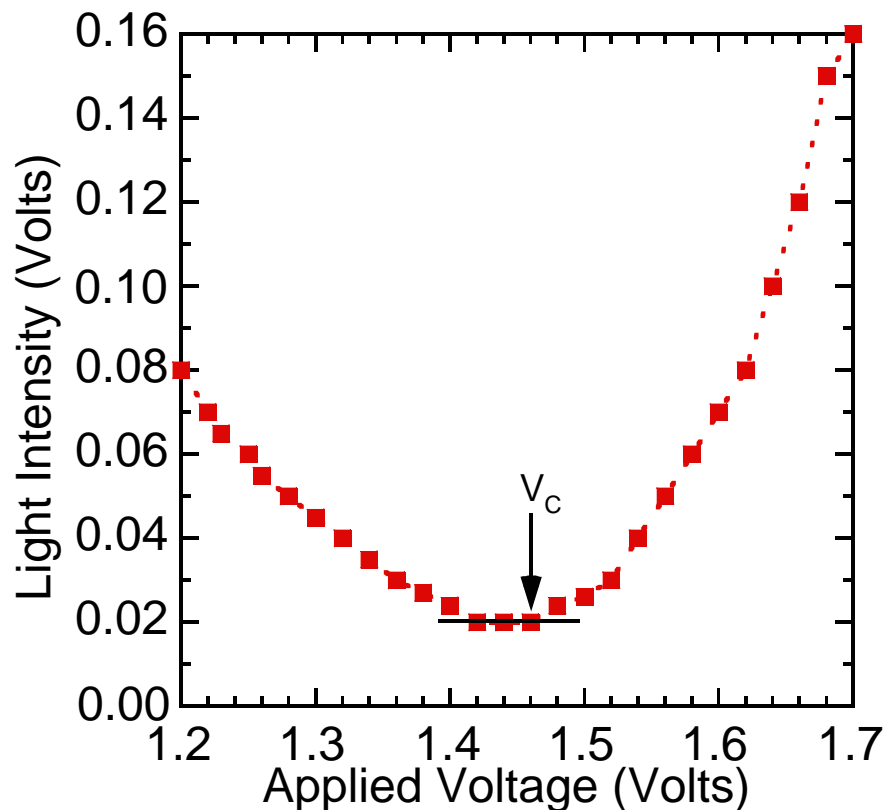

(The data shown in this graph do not correspond to the data shown on the previous page. This graph only shows how to obtain V_c .)

Part C: Optical Properties of Nematic Liquid Crystal :
Electro-optical switching characteristic of parallel aligned LC cell

Question C-(1) (2.5 points)

Assume that the wavelength of laser light 650 nm, LC layer thickness 7.7 μm , and approximate value of $\Delta n \approx 0.25$ are known. From the experimental data T_{\perp} and T_{\parallel} obtained above, calculate the accurate value of the phase retardation δ and accurate value of birefringence Δn of this LC cell at $V=0$.

a. Adequate value of δ and Δn with error.

- Take and average the values of T_{\parallel} . (0.3 pts)
- Take and average the values of T_{\perp} . (0.3 pts)
- Determine the value of order m . (0.9 pts)
- Correct δ value, 15.7 ~ 18.2. (0.5 pts)
- Correct Δn value, 0.20 ~ 0.24 (0.5 pts)

$$T_{\parallel} = \frac{0.31 + 0.31 + 0.31}{3} = 0.31 \pm 0.01 \text{ Volts}$$

$$T_{\perp} = \frac{1.04 + 1.03 + 1.04}{3} = 1.04 \pm 0.01 \text{ Volts}$$

$$\tan \frac{\delta}{2} = \pm \frac{\sqrt{T_{\perp}}}{\sqrt{T_{\parallel}}} = -1.83^* \quad \therefore \delta = 4.14 + 2m\pi \quad (\text{or } -2.14 + 2m\pi)$$

$$\delta = \frac{2\pi d \Delta n}{\lambda} = \frac{2\pi \times 7.7 \times 0.25}{0.65} = 18.61$$

$$\text{Take } m = 2(\text{or } 3) \quad \therefore \delta = 16.70(5.32\pi)$$

$$\text{From } \delta = \frac{2\pi d \Delta n}{\lambda} \quad \therefore \Delta n = \frac{\delta \lambda}{2\pi d} = 0.22$$

Accepted value for $\therefore \Delta n = (0.20 \sim 0.24)$

*If $\tan \frac{\delta}{2} = 1.83$, the value for δ will be either 4.68π or 6.68π , which is not consistent with data figure of problem C-(2).

Question C-(2) (Total 3.0 points)

Measure, tabulate, and plot the electro-optical switching curve for T_{\parallel} of this parallel aligned LC cell in the $\theta = 45^\circ$ configuration.

a. Proper data table marked with variables and units. (0.3 pts)

Applied voltage (Volts)	Light intensity (Volts)	Applied voltage (Volts)	Light intensity (Volts)	Applied voltage (Volts)	Light intensity (Volts)
0.00	0.30	2.01	1.47	3.33	0.00
0.10	0.30	2.04	1.48	3.36	0.00
0.20	0.29	2.07	1.48	3.39	0.00
0.30	0.29	2.10	1.48	3.42	0.00
0.40	0.29	2.13	1.45	3.45	0.00
0.50	0.28	2.16	1.42	3.48	0.00
0.60	0.26	2.19	1.38	3.51	0.00
0.70	0.23	2.22	1.33	3.60	0.01
0.80	0.19	2.25	1.27	3.70	0.02
0.90	0.09	2.28	1.20	3.80	0.03
0.99	0.00	2.31	1.14	3.90	0.04
1.02	0.06	2.34	1.07	4.00	0.07
1.05	0.16	2.37	1.00	4.10	0.09
1.08	0.25	2.40	0.94	4.20	0.11
1.11	0.40	2.43	0.87	4.30	0.14
1.14	0.67	2.46	0.79	4.40	0.16
1.17	0.93	2.49	0.72	4.50	0.19
1.20	1.25	2.52	0.66	4.60	0.22
1.26	1.31	2.55	0.61	4.70	0.25
1.29	1.36	2.58	0.56	4.80	0.28
1.32	1.32	2.61	0.51	4.90	0.31
1.35	1.09	2.64	0.46	5.01	0.34
1.38	0.85	2.67	0.42	5.11	0.37
1.41	0.62	2.70	0.37	5.21	0.39
1.44	0.46	2.73	0.33	5.29	0.42
1.47	0.29	2.76	0.30	5.39	0.44
1.50	0.13	2.79	0.26	5.51	0.48
1.53	0.06	2.82	0.23	5.57	0.49
1.59	0.03	2.85	0.21	5.70	0.52
1.62	0.05	2.88	0.18	5.80	0.55
1.65	0.15	2.91	0.16	5.90	0.57
1.68	0.24	2.94	0.14	6.01	0.60
1.71	0.34	2.97	0.12	6.10	0.62
1.74	0.49	3.00	0.09	6.19	0.64
1.77	0.63	3.06	0.08	6.30	0.66
1.80	0.78	3.09	0.06	6.40	0.69
1.83	0.92	3.12	0.05	6.60	0.73
1.86	1.05	3.18	0.04	6.70	0.74
1.89	1.19	3.21	0.03	6.80	0.76
1.92	1.27	3.24	0.02	7.00	0.80
1.95	1.34	3.27	0.02	7.20	0.83
1.98	1.40	3.30	0.01		

- b. Properly choose the size of scales and units for abscissa and ordinate that bears the relation to the accuracy and range of the experiment. (0.3 pts)
- c. Correct measurement of the T_{\parallel} as a function of the applied voltage (V_{rms}) and adequate T_{\parallel} - V_{rms} curve plot.
- Three minima and two sharp maxima. (1.5 pts)
 - Maxima values within 15% from each other. (0.5 pts)
 - Minima are less than the values of 0.1 Volts. (0.4 pts)

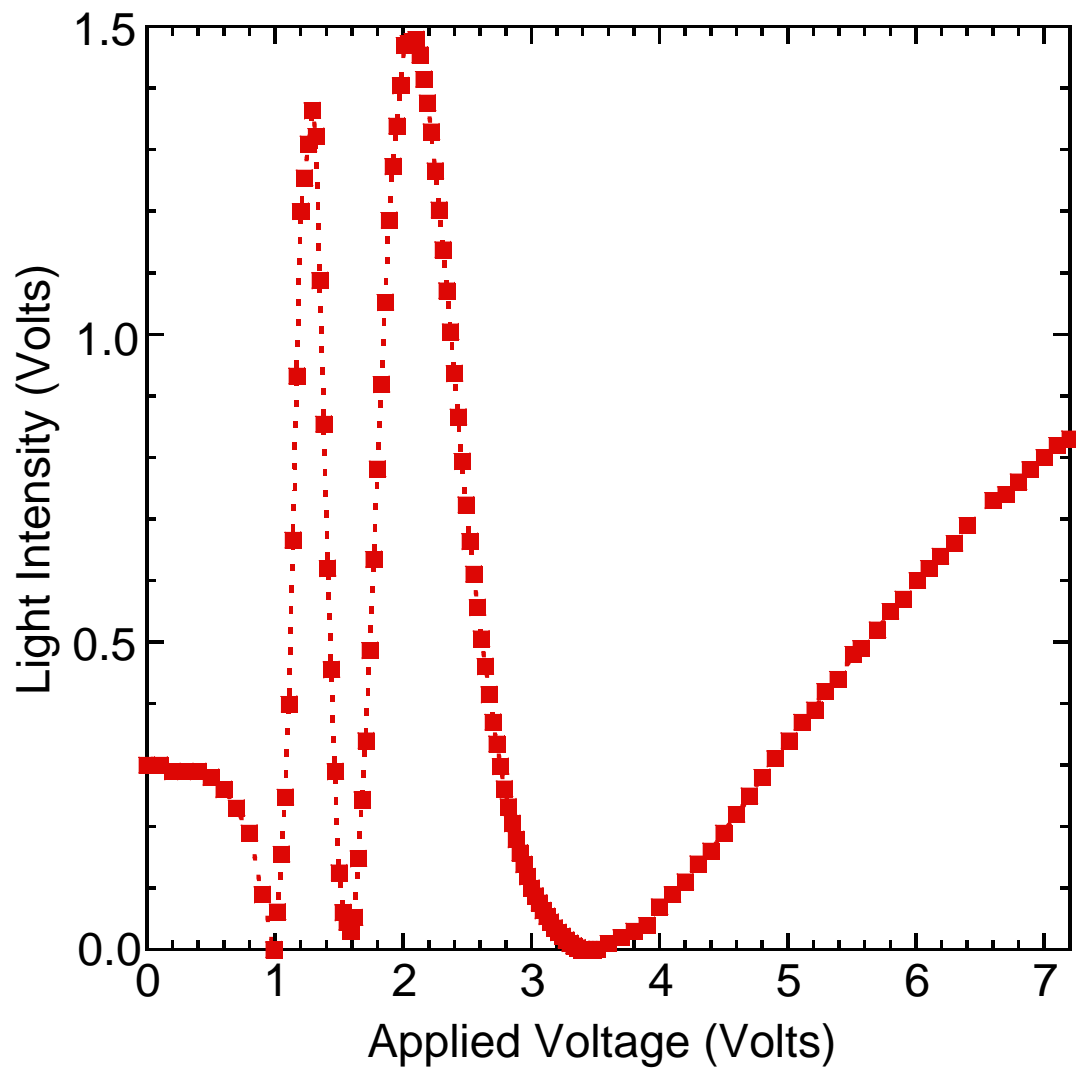

Question C-(3) (Total 2.0 points)

From the electro-optical switching data, find the value of the external applied voltage V_π .

a. Adequate value of V_π with error.

- Make the expanded scale plot and take more data points in the region of V_π . (0.3 pts)
- Indicate the correct minimum of V_π . (0.8 pts)
- Obtain the value of V_π by interpolation or rounding. (0.5 pts)
- Correct V_π value : $(3.2 \sim 3.5) \pm 0.01$ Volts. (0.2+0.2 pts)

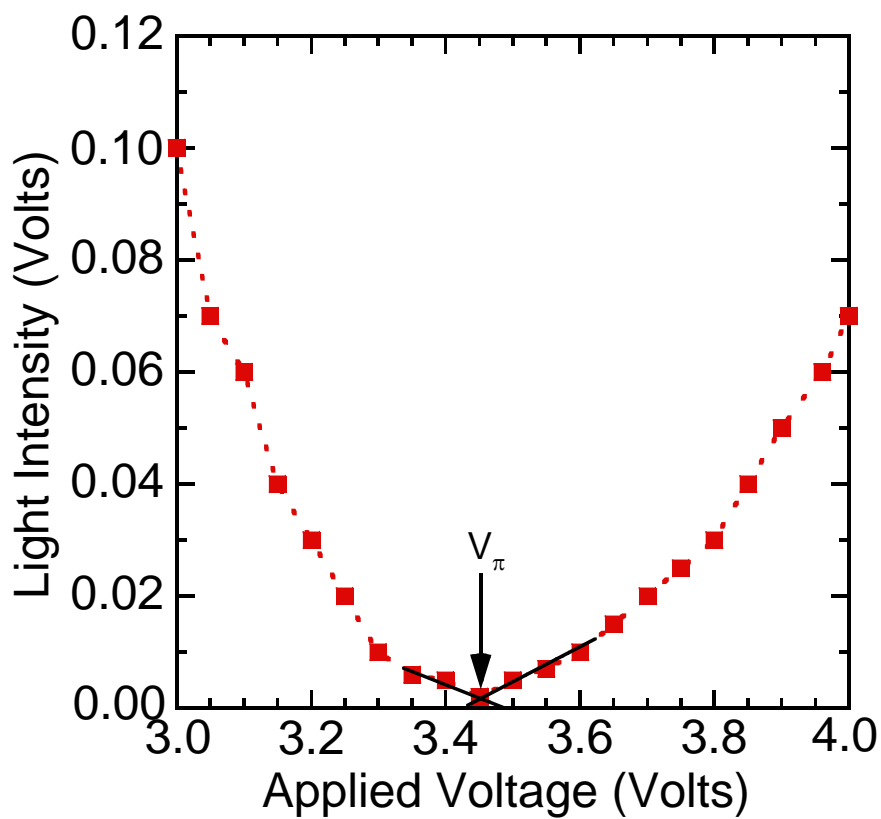

Marking Scheme

Part A: Optical Properties of Laser Diode

No.	Contents	Sub Scores	Total Scores
A(1)	Measure, tabulate, and plot the J vs. I curve.		1.5 pts.
a	Proper data table marked with variables and units.	0.3	
b	Proper sizes of scales, and units for abscissa and ordinate that bear relation to the accuracy and range of the experiment.	0.3	
c	Proper data and adequate curve plotting (Fig. A-1)	0.9	
A(2)	Estimate the maximum current I_m with uncertainty in the linear region of the J vs. I curve. Mark the linear region on the J - I curve figure by using arrows (\downarrow) and determine the threshold current I_{th} with uncertainty.		3.5 pts.
a	Mark the linear region.	0.5	
b	Least-square fit or eye-balling with ruler and error analysis	1.5	
c	Obtain $I_m \pm \Delta I_m$ properly	0.5	
d	Adequate value of $I_{th} \pm \Delta I_{th}$	1.0	

Part B: Optical Properties of Nematic Liquid Crystal

Electro-optical switching characteristic of 90° TN LC cell

No.	Contents	Sub Scores	Total Scores
B-(1)	Measure, tabulate, and plot the electro-optical switching curve (J vs. V_{rms} curve) of the NB 90° TN LC, and find its switching slope γ , where γ is defined as $(V_{90} - V_{10})/V_{10}$.		5.0 pts.
a	Proper data table marked with variables and units.	0.3	
b	Properly choose the size of scales and units for abscissa and ordinate that bears the relation to the accuracy and range of the experiment.	0.3	
c	Correct measurement of the light intensity (J) as a function of the applied voltage (V_{rms}) and adequate J - V_{rms} curve plot.		
	<ul style="list-style-type: none"> ■ The intensity of the transmission light reaches zero value in the normally black mode. 	0.4	
	<ul style="list-style-type: none"> ■ There is a small optical bounce before the external applied voltage reaches the critical voltage. 	0.8	
	<ul style="list-style-type: none"> ■ The intensity of the transmission light increases rapidly and 	0.4	

	abruptly when the external applied voltage exceeds the critical voltage.		
	<ul style="list-style-type: none"> ■ The intensity of the transmission light displays the plateau behavior as the external applied voltage exceeds 3.0 Volts. 	0.4	
d	Adequate value of γ with error, $\gamma \pm \Delta\gamma$.		
	<ul style="list-style-type: none"> ■ Correctly analyzing the maximum light intensity. 	0.6	
	<ul style="list-style-type: none"> ■ Correctly analyzing the value of V_{90}. 	0.6	
	<ul style="list-style-type: none"> ■ Correctly analyzing the value of V_{10}. 	0.6	
	<ul style="list-style-type: none"> ■ Correct $\gamma \pm \Delta\gamma$ value, $(0.42 \sim 0.44) \pm 0.02$. 	0.6	
B-(2)	Determine the critical voltage V_c of this NB 90° TN LC cell. Show explicitly with graph how you determine the value V_c .		2.5 pts.
	Adequate value of V_C with error, $V_C \pm \Delta V_C$.		
	<ul style="list-style-type: none"> ■ Make the expanded scale plot and take more data points in the region of V_C. 	0.8	
	<ul style="list-style-type: none"> ■ Correctly analyzing the value of V_C. 	0.7	
	<ul style="list-style-type: none"> ■ Correct $V_C \pm \Delta V_C$ value, $(1.2 \sim 1.5) \pm 0.01$ Volts. 	1.0	

Part C: Optical Properties of Nematic Liquid Crystal :

Electro-optical switching characteristic of parallel aligned LC cell

No.	Contents	Sub Scores	Total Scores
C-(1)	Assume that the wavelength of laser light 650 nm, LC layer thickness $7.7 \mu\text{m}$, and approximate value of $\Delta n \approx 0.25$ are known. From the experimental data T_\perp and T_\parallel obtained above, calculate the accurate value of the phase retardation δ and accurate value of birefringence Δn of this LC cell at $V=0$.		2.5 pts.
	Adequate value of δ and Δn with error.		
	<ul style="list-style-type: none"> ■ Correctly analyzing the values of T_\parallel. 	0.3	
	<ul style="list-style-type: none"> ■ Correctly analyzing the values of T_\perp. 	0.3	
	<ul style="list-style-type: none"> ■ Correctly determining the value of order m. 	0.9	
	<ul style="list-style-type: none"> ■ Correct δ value, $17.7 \sim 18.2$. 	0.5	
	<ul style="list-style-type: none"> ■ Correct Δn value, $0.23 \sim 0.25$. 	0.5	
C-(2)	Measure, tabulate, and plot the electro-optical switching curve for T of this parallel aligned LC cell in the $\theta = 45^\circ$ configuration.		3.0 pts.
a	Proper data table marked with variables and units.	0.3	
b	Properly choose the size of scales and units for abscissa and ordinate	0.3	

	that bears the relation to the accuracy and range of the experiment.		
c	Correct measurement of the T_{\parallel} as a function of the applied voltage (V_{rms}) and adequate $T_{\parallel} - V_{\text{rms}}$ curve plot.		
	■ Three minima and two sharp maxima.	1.5	
	■ Maxima values within 15 % from each other.	0.5	
	■ Minima are less than the values of 0.1 Volts.	0.4	
C-(3)	From the electro-optical switching data, find the value of the external applied voltage V_{π}		2.0 pts.
	Adequate value of V_{π} with error.		
	■ Make the expanded scale plot and take more data points in the region of V_{π} .	0.3	
	■ Indicate the correct minimum of V_{π} .	0.8	
	■ Correctly analyzing the value of V_{π} .	0.5	
	■ Correct $V_{\pi} \pm \Delta V_{\pi}$ value, $(3.2 \sim 3.5) \pm 0.1$ Volts.	0.4	

Theoretical Question 1:

“Ping-Pong” Resistor

A capacitor consists of two circular parallel plates both with radius R separated by distance d , where $d \ll R$, as shown in Fig. 1.1(a). The top plate is connected to a constant voltage source at a potential V while the bottom plate is grounded. Then a thin and small disk of mass m with radius r ($\ll R, d$) and thickness t ($\ll r$) is placed on the center of the bottom plate, as shown in Fig. 1.1(b).

Let us assume that the space between the plates is in vacuum with the dielectric constant ϵ_0 ; the plates and the disk are made of perfect conductors; and all the electrostatic edge effects may be neglected. The inductance of the whole circuit and the relativistic effects can be safely disregarded. The image charge effect can also be neglected.

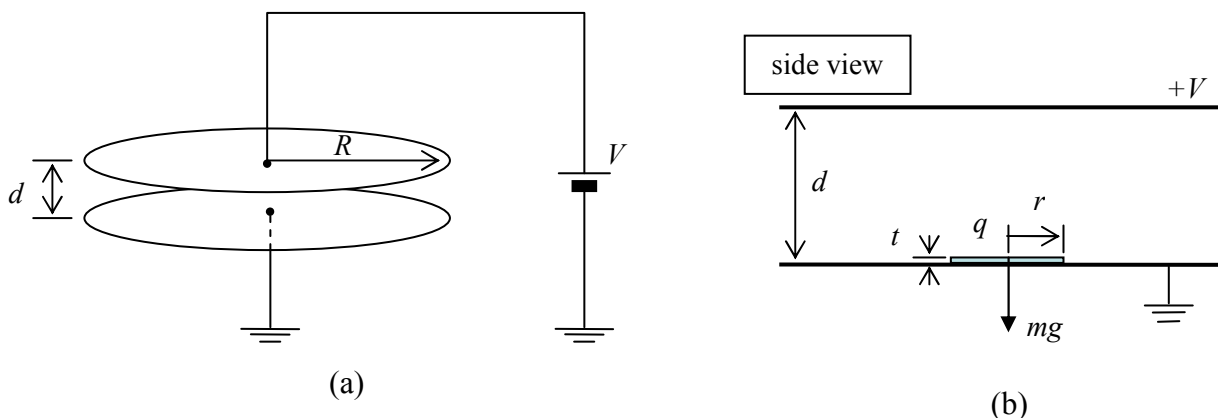

Figure 1.1 Schematic drawings of (a) a *parallel plate* capacitor connected to a constant voltage source and (b) a side view of the *parallel plates* with a small *disk* inserted inside the capacitor. (See text for details.)

(a) [1.2 points] Calculate the electrostatic force F_p between *the plates* separated by d before inserting the disk in-between as shown in Fig. 1.1(a).

(b) [0.8 points] When the disk is placed on the bottom plate, a charge q on *the disk* of Fig. 1.1(b) is related to the voltage V by $q = \chi V$. Find χ in terms of r , d , and ϵ_0 .

(c) [0.5 points] The parallel plates lie perpendicular to a uniform gravitational field g . To lift up the disk at rest initially, we need to increase the applied voltage beyond a

threshold voltage V_{th} . Obtain V_{th} in terms of m , g , d , and χ .

(d) [2.3 points] When $V > V_{\text{th}}$, the disk makes an up-and-down motion between the plates. (Assume that the disk moves only vertically *without any wobbling*.) The collisions between the disk and the plates are inelastic with the restitution coefficient $\eta \equiv (v_{\text{after}} / v_{\text{before}})$, where v_{before} and v_{after} are the speeds of the disk just before and after the collision respectively. The plates are stationary fixed in position. The speed of the disk *just after* the collision at the bottom plate approaches a “steady-state speed” v_s , which depends on V as follows:

$$v_s = \sqrt{\alpha V^2 + \beta}. \quad (1.1)$$

Obtain the coefficients α and β in terms of m , g , χ , d , and η . Assume that the whole surface of the disk touches the plate evenly and simultaneously so that the complete charge exchange happens instantaneously at every collision.

(e) [2.2 points] After reaching its steady state, the time-averaged current I through the capacitor plates can be approximated by $I = \gamma V^2$ when $qV \gg mgd$. Express the coefficient γ in terms of m , χ , d , and η .

(f) [3 points] When the applied voltage V is decreased (extremely slowly), there exists a critical voltage V_c below which the charge will cease to flow. Find V_c and the corresponding current I_c in terms of m , g , χ , d , and η . By comparing V_c with the lift-up threshold V_{th} discussed in (c), make a rough sketch of the $I-V$ characteristics when V is increased and decreased in the range from $V = 0$ to $3V_{\text{th}}$.

Country Code	Student Code	Question Number
		1

Answer Form

Theoretical Question 1:

(a) $F_p =$

(b) $\chi =$

(c) $V_{th} =$

(d) $\alpha =$

$\beta =$

(e) $\gamma =$

(f) $I_c =$

$V_c =$

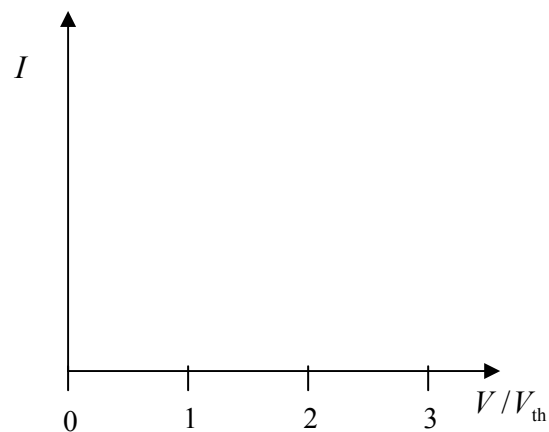

Theoretical Question 2

Rising Balloon

A rubber balloon filled with helium gas goes up high into the sky where the pressure and temperature decrease with height. In the following questions, assume that the shape of the balloon remains spherical regardless of the payload, and neglect the payload volume. Also assume that the temperature of the helium gas inside of the balloon is always the same as that of the ambient air, and treat all gases as ideal gases. The universal gas constant is $R=8.31 \text{ J/mol}\cdot\text{K}$ and the molar masses of helium and air are $M_H = 4.00 \times 10^{-3} \text{ kg/mol}$ and $M_A = 28.9 \times 10^{-3} \text{ kg/mol}$, respectively. The gravitational acceleration is $g = 9.8 \text{ m/s}^2$.

[Part A]

(a) [1.5 points] Let the pressure of the ambient air be P and the temperature be T . The pressure inside of the balloon is higher than that of outside due to the surface tension of the balloon. The balloon contains n moles of helium gas and the pressure inside is $P + \Delta P$. Find the buoyant force F_B acting on the balloon as a function of P and ΔP .

(b) [2 points] On a particular summer day in Korea, the air temperature T at the height z from the sea level was found to be $T(z) = T_0(1 - z/z_0)$ in the range of $0 < z < 15$ km with $z_0 = 49$ km and $T_0 = 303$ K. The pressure and density at the sea level were $P_0 = 1.0 \text{ atm} = 1.01 \times 10^5 \text{ Pa}$ and $\rho_0 = 1.16 \text{ kg/m}^3$, respectively. For this height range, the pressure takes the form

$$P(z) = P_0(1 - z/z_0)^\eta . \quad (2.1)$$

Express η in terms of z_0 , ρ_0 , P_0 , and g , and find its numerical value to the *two* significant digits. Treat the gravitational acceleration as a constant, independent of height.

[Part B]

When a rubber balloon of spherical shape with un-stretched radius r_0 is inflated to a sphere of radius r ($\geq r_0$), the balloon surface contains extra elastic energy due to the stretching. In a simplistic theory, the elastic energy at constant temperature T can be expressed by

$$U = 4\pi r_0^2 \kappa RT \left(2\lambda^2 + \frac{1}{\lambda^4} - 3 \right) \quad (2.2)$$

where $\lambda \equiv r/r_0$ (≥ 1) is the size-inflation ratio and κ is a constant in units of mol/m².

(c) [2 points] Express ΔP in terms of parameters given in Eq. (2.2), and sketch ΔP as a function of $\lambda = r/r_0$.

(d) [1.5 points] The constant κ can be determined from the amount of the gas needed to inflate the balloon. At $T_0 = 303$ K and $P_0 = 1.0$ atm = 1.01×10^5 Pa, an un-stretched balloon ($\lambda = 1$) contains $n_0 = 12.5$ moles of helium. It takes $n = 3.6 n_0 = 45$ moles in total to inflate the balloon to $\lambda = 1.5$ at the same T_0 and P_0 . Express the balloon parameter a , defined as $a = \kappa/\kappa_0$, in terms of n , n_0 , and λ , where $\kappa_0 \equiv \frac{r_0 P_0}{4RT_0}$. Evaluate a to the two significant digits.

[Part C]

A balloon is prepared as in (d) at the sea level (inflated to $\lambda = 1.5$ with $n = 3.6 n_0 = 45$ moles of helium gas at $T_0 = 303$ K and $P_0 = 1$ atm = 1.01×10^5 Pa). The total mass including gas, balloon itself, and other payloads is $M_T = 1.12$ kg. Now let the balloon rise from the sea level.

(e) [3 points] Suppose that the balloon eventually stops at the height z_f where the buoyant force balances the total weight. Find z_f and the inflation ratio λ_f at that

height. Give the answers in two significant digits. Assume there are no drift effect and no gas leakage during the upward flight.

Country Code	Student Code	Question Number
		2

Answer Form

Theoretical Question 2:

(a) $F_B =$

(b) $\eta =$

Numerical value of $\eta =$

(c) $\Delta P =$

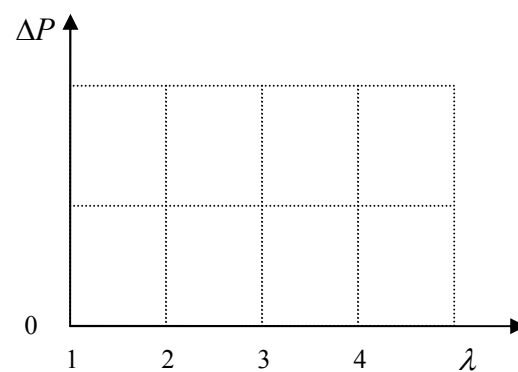

(d) $a =$

Numerical value of $a =$

(e) $z_f =$

km

$\lambda_f =$

Theoretical Question 3

Atomic Probe Microscope

Atomic probe microscopes (APMs) are powerful tools in the field of nano-science. The motion of a cantilever in APM can be detected by a photo-detector monitoring the reflected laser beam, as shown in Fig. 3.1. The cantilever can move only in the vertical direction and its displacement z as a function of time t can be described by the equation

$$m \frac{d^2 z}{dt^2} + b \frac{dz}{dt} + kz = F, \quad (3.1)$$

where m is the cantilever mass, $k = m\omega_0^2$ is the spring constant of the cantilever, b is a small damping coefficient satisfying $\omega_0 \gg (b/m) > 0$, and finally F is an external driving force of the piezoelectric tube.

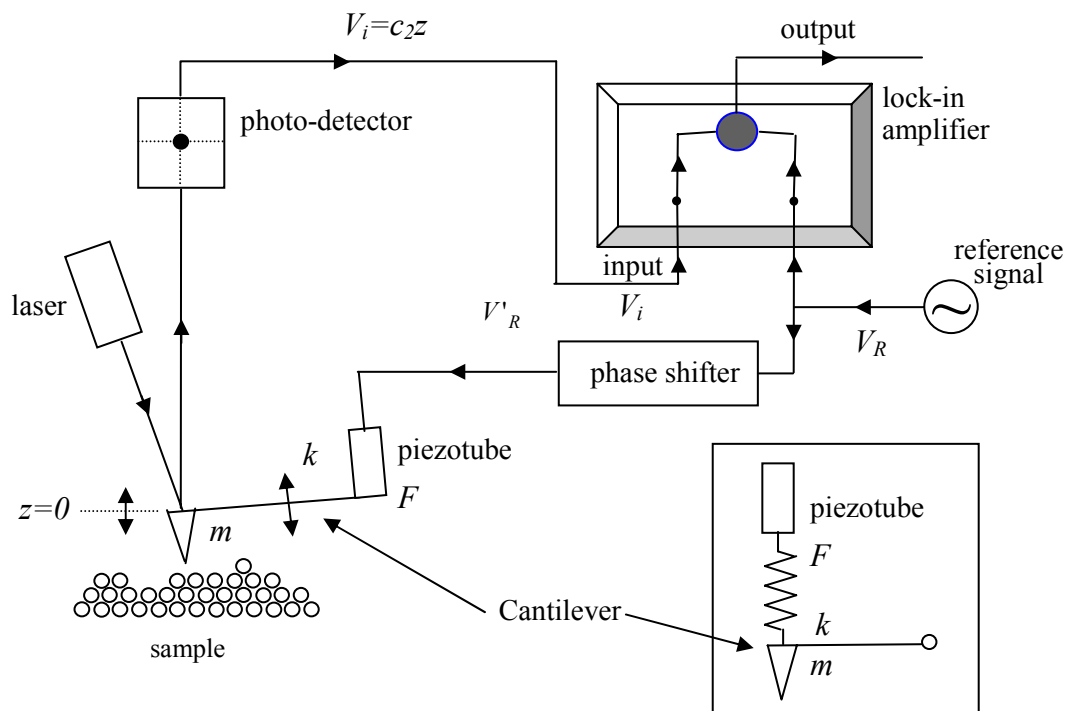

Figure 3.1 A schematic diagram for a scanning probe microscope (SPM). The inset in the lower right corner represents a simplified mechanical model to describe the coupling of the piezotube with the cantilever.

[Part A]

(a) [1.5 points] When $F = F_0 \sin \omega t$, $z(t)$ satisfying Eq. (3.1) can be written as $z(t) = A \sin(\omega t - \phi)$, where $A > 0$ and $0 \leq \phi \leq \pi$. Find the expression of the

amplitude A and $\tan\phi$ in terms of F_0 , m , ω , ω_0 , and b . Obtain A and the phase ϕ at the resonance frequency $\omega = \omega_0$.

(b) [1 point] A lock-in amplifier shown in Fig.3.1 multiplies an input signal by the lock-in reference signal, $V_R = V_{R0} \sin \omega t$, and then passes *only* the dc (direct current) component of the multiplied signal. Assume that the input signal is given by $V_i = V_{i0} \sin(\omega_i t - \phi_i)$. Here V_{R0} , V_{i0} , ω_i , and ϕ_i are all positive given constants. Find the condition on ω (>0) for a non-vanishing output signal. What is the expression for the magnitude of the non-vanishing *dc output signal* at this frequency?

(c) [1.5 points] Passing through the phase shifter, the lock-in reference voltage $V_R = V_{R0} \sin \omega t$ changes to $V'_R = V_{R0} \sin(\omega t + \pi/2)$. V'_R , applied to the piezoelectric tube, drives the cantilever with a force $F = c_1 V'_R$. Then, the photo-detector converts the displacement of the cantilever, z , into a voltage $V_i = c_2 z$. Here c_1 and c_2 are constants. Find the expression for the magnitude of the *dc output signal* at $\omega = \omega_0$.

(d) [2 points] The small change Δm of the cantilever mass shifts the resonance frequency by $\Delta\omega_0$. As a result, the phase ϕ at the original resonance frequency ω_0 shifts by $\Delta\phi$. Find the mass change Δm corresponding to the phase shift $\Delta\phi = \pi/1800$, which is a typical resolution in phase measurements. The physical parameters of the cantilever are given by $m = 1.0 \times 10^{-12}$ kg, $k = 1.0$ N/m, and $(b/m) = 1.0 \times 10^3$ s⁻¹. Use the approximations $(1+x)^a \approx 1+ax$ and $\tan(\pi/2+x) \approx -1/x$ when $|x| \ll 1$.

[Part B]

From now on let us consider the situation that some forces, besides the driving force discussed in Part A, act on the cantilever due to the sample as shown in Fig.3.1.

(e) [1.5 points] Assuming that the additional force $f(h)$ depends only on the distance h between the cantilever and the sample surface, one can find a new equilibrium position h_0 . Near $h = h_0$, we can write $f(h) \approx f(h_0) + c_3(h - h_0)$, where c_3 is a constant in h . Find the new resonance frequency ω'_0 in terms of ω_0 , m , and c_3 .

(f) [2.5 points] While scanning the surface by moving the sample horizontally, the tip of the cantilever charged with $Q = 6e$ encounters an electron of charge $q = e$ trapped

(localized in space) at some distance below the surface. During the scanning around the electron, the maximum shift of the resonance frequency $\Delta\omega_0 (= \omega'_0 - \omega_0)$ is observed to be much smaller than ω_0 . Express the distance d_0 from the cantilever to the trapped electron at the maximum shift in terms of m , q , Q , ω_0 , $\Delta\omega_0$, and the Coulomb constant k_e . Evaluate d_0 in nm ($1 \text{ nm} = 1 \times 10^{-9} \text{ m}$) for $\Delta\omega_0 = 20 \text{ s}^{-1}$.

The physical parameters of the cantilever are $m = 1.0 \times 10^{-12} \text{ kg}$ and $k = 1.0 \text{ N/m}$. Disregard any polarization effect in both the cantilever tip and the surface. Note that $k_e = 1/4\pi\epsilon_0 = 9.0 \times 10^9 \text{ N}\cdot\text{m}^2/\text{C}^2$ and $e = -1.6 \times 10^{-19} \text{ C}$.

Country Code	Student Code	Question Number
		3

Answer Form

Theoretical Question 3:

(a) $A =$ and $\tan \phi =$

At $\omega = \omega_0$, $A =$ and $\phi =$

(b) The condition on ω for a non-vanishing output signal :

The magnitude of the dc signal =

(c) The magnitude of the signal =

(d) $\Delta m =$

kg

Country Code	Student Code	Question Number
		3

(e) $\omega'_0 =$

(f) $d_0 =$; Evaluated $d_0 =$ nm.



35th International Physics Olympiad

Pohang, Korea

15 ~ 23 July 2004

Experimental Competition

Monday, 19 July 2004

Please, first read the following instruction carefully:

1. The time available is 5 hours.
2. Use only the pen provided.
3. Use only the front side of the *writing sheets*. Write only inside the boxed area.
4. In addition to the *blank writing sheets*, there are *Answer Forms* where you *must* summarize the results you have obtained.
5. Write on the *blank writing sheets* the results of your measurements and whatever else you consider is required for the solution to the question. Please, use *as little text as possible*; express yourself primarily in equations, numbers, figures, and plots.
6. In the boxes at the top of each sheet of paper write down your country code (*Country Code*) and student number (*Student Code*). In addition, on each *blank writing sheets*, write down the progressive number of each sheet (*Page Number*) and the total number of *writing sheets* used (*Total Number of Pages*). If you use some *blank writing sheets* for notes that you do not wish to be marked, put a large X across the entire sheet and do not include it in your numbering.
7. At the end of the experiment, arrange all sheets *in the following order*:
 - *Answer forms* (top)
 - used *writing sheets* in order
 - the sheets you do not wish to be marked
 - unused *writing sheets*
 - the printed question (bottom)
8. It is not necessary to specify the error range of your values. However, their deviations from the actual values will determine your mark.
9. Place the papers inside the envelope and leave everything on your desk. **You are not allowed to take any sheet of paper or any material used in the experiment out of the room.**

Apparatus and materials

1. List of available apparatus and materials

	Name	Quantity		Name	Quantity
A	Photogate timer	1	L	Philips screw driver	1
B	Photogate	1	M	Weight with a string	1
C	Connecting cable	1	N	Electronic balance	1
D	Mechanical “black box” (Black cylinder)	1	O	Stand with a ruler	1
E	Rotation stage	1	P	U-shaped support	1
F	Rubber pad	1	Q	C-clamp	1
G	Pulley	2		Ruler (0.50 m, 0.15 m)	1 each
H	Pin	2		Vernier calipers	1
I	U-shaped plate	1		Scissors	1
J	Screw	2		Thread	1
K	Allen (hexagonal, L- shaped) wrench	1		Spares (string, thread, pin, screw, Allen wrench)	

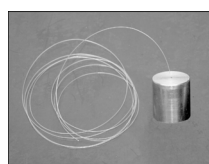
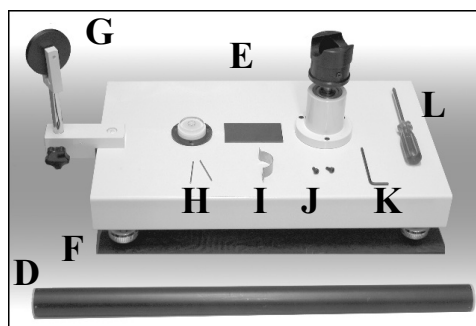
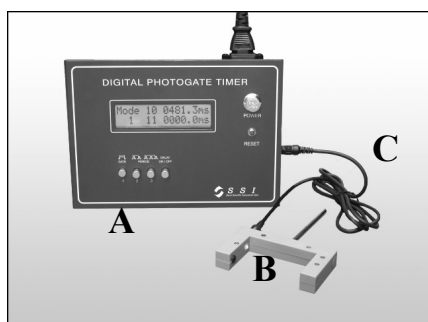

M



N

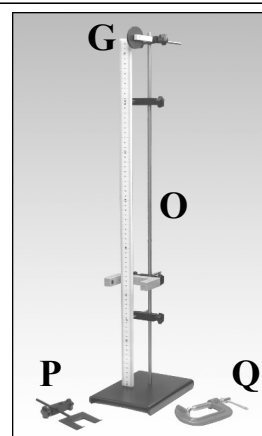

O, P, Q

2. Instruction for the Photogate Timer

The Photogate consists of an infrared LED and a photodetector. By connecting the Photogate to the Photogate Timer, you can measure the time duration related to the blocking of the infrared light reaching the sensor.

- Be sure that the Photogate is connected to the Photogate Timer. Turn on the power by pushing the button labelled “POWER”.
- To measure the time duration of a single blocking event, push the button labelled “GATE”. Use this “GATE” mode for speed measurements.
- To measure the time interval between two or three successive blocking events, push the corresponding “PERIOD”. Use this “PERIOD” mode for oscillation measurements.
- If “DELAY” button is pushed in, the Photogate Timer displays the result of each measurement for 5 seconds and then resets itself.
- If “DELAY” button is pushed out, the Photogate Timer displays the result of the previous measurement until the next measurement is completed.
- After any change of button position, press the “RESET” button once to activate the mode change.

Caution: Do not look directly into the Photogate. The invisible infrared light may be harmful to your eyes.



Photogate, Photogate Timer, and connection cable

3. Instruction for the Electronic Balance

- Adjust the bottom legs to set the balance stable. (Although there is a level indicator, setting the balance in a completely horizontal position is not necessary.)
- Without putting anything on the balance, turn it on by pressing the “On/Off” button.
- Place an object on the round weighing pan. Its mass will be displayed in grams.
- If there is nothing on the weighing pan, the balance will be turned off automatically in about 25 seconds.



Balance

4. Instruction for the Rotation Stage

- Adjust the bottom legs to set the rotation stage stable on a rubber pad in a near horizontal position.
- With a U-shaped plate and two screws, mount the Mechanical “Black Box” (black cylinder) on the top of the rotating stub. Use Allen (hexagonal, L-shaped) wrench to tighten the screws.
- The string attached to the weight is to be fixed to the screw on the side of the rotating stub. Use the Philips screw driver.

Caution: Do not look too closely at the Mechanical “Black Box” while it is rotating. Your eyes may get hurt.

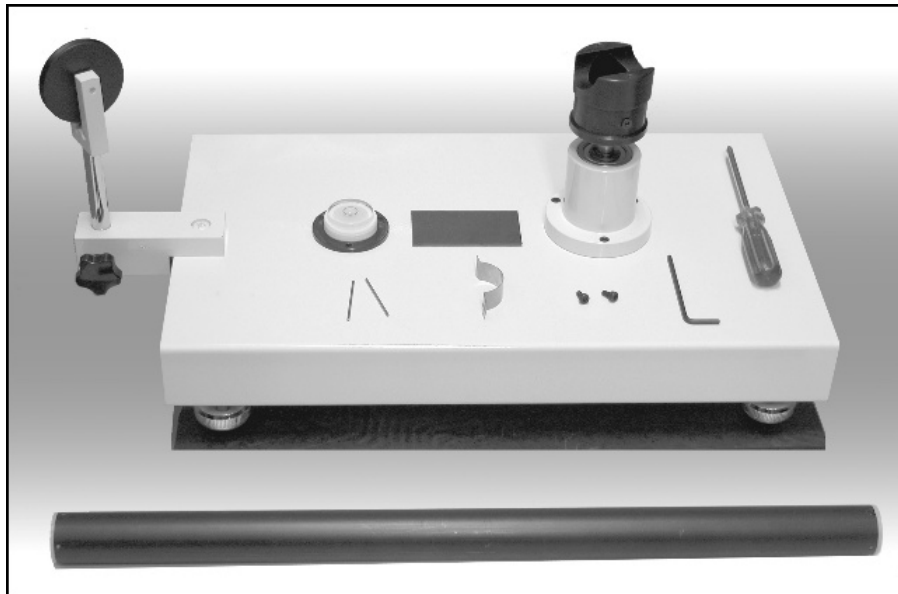

Mechanical “Black Box” and rotation stage



Rotating stub

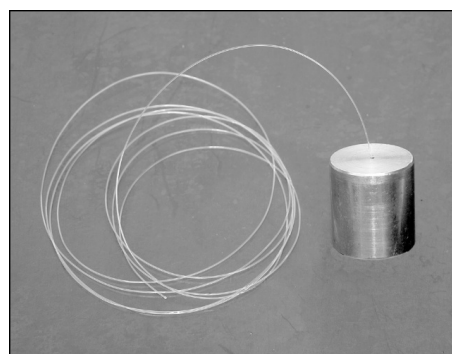

Weight with a string

Mechanical “Black Box”

[Question] Find the mass of the ball and the spring constants of two springs in the Mechanical “Black Box”.

General Information on the Mechanical “Black Box”

The Mechanical “Black Box” (MBB) consists of a solid ball attached to two springs in a black cylindrical tube as shown in Fig. 1. The two springs are fashioned from the same tightly wound spring with different number of turns. The masses and the lengths of the springs when they are not extended can be ignored. The tube is homogeneous and sealed with two identical end caps. The part of the end caps plugged into the tube is 5 mm long. The radius of the ball is 11 mm and the inner diameter of the tube is 23 mm. The gravitational acceleration is given as $g = 9.8 \text{ m/s}^2$. There is a finite friction between the ball and the inner walls of the tube.

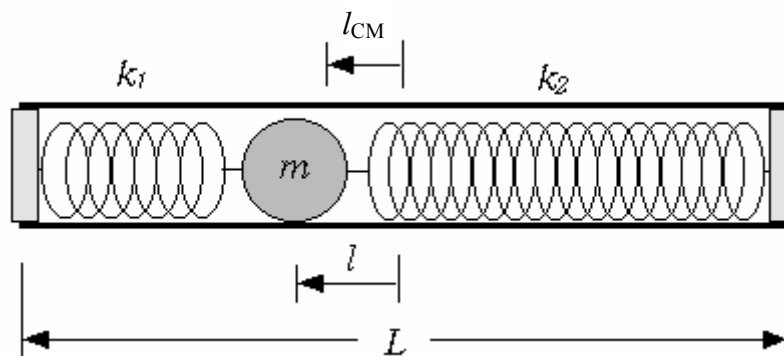

Fig. 1 Mechanical “Black Box” (not to scale)

The purpose of this experiment is to find out the mass m of the ball and the spring constants k_1 and k_2 of the springs without opening the MBB. The difficult aspect of this problem is that any single experiment cannot provide the mass m or the position l of the ball because the two quantities are interconnected. Here, l is the distance between the centers of the tube and the ball when the MBB lies horizontally in equilibrium when the friction is zero.

The symbols listed below should be used to represent the physical quantities of interest. If you need to use other physical quantities, use symbols different from those already assigned below to avoid confusion.

Assigned Physical Symbols

Mass of the ball: m

Radius of the ball: r (= 11 mm)

Mass of the MBB excluding the ball: M

Length of the black tube: L

Length of each end cap extending into the tube: δ (= 5.0 mm)

Distance from the center-of-mass of the MBB to the center of the tube: l_{CM}

Distance between the center of the ball and the center of the tube: x (or l at equilibrium when the MBB is horizontal)

Gravitational acceleration: g (= 9.8 m/s²)

Mass of the weight attached to a string: m_0

Speed of the weight: v

Downward displacement of the weight: h

Radius of the rotating stub where the string is to be wound: R

Moments of inertia: I, I_0, I_1, I_2 , and so on

Angular velocity and angular frequencies: $\omega, \omega_1, \omega_2$, and so on

Periods of oscillation: T_1, T_2

Effective total spring constant: k

Spring constants of the two springs: k_1, k_2

Number of turns of the springs: N_1, N_2

Caution: Do not try to open the MBB. If you open it, you will be disqualified and your mark in the Experimental Competition will be zero.

Caution: Do not shake violently nor drop the MBB. The ball may be detached from the springs. If your MBB seems faulty, report to the proctors immediately. It will be replaced only once without affecting your mark. Any further replacement will cut down your mark by 0.5 points each time.

PART-A Product of the mass and the position of the ball ($m \times l$) (4.0 points)

l is the position of the center of the ball relative to that of the tube when the MBB lies horizontally in equilibrium as in Fig. 1. Find the value of the product of the mass m and the position l of the ball experimentally. You will need this to determine the value of m in **PART-B**.

1. Suggest and justify, by using equations, a method allowing to obtain $m \times l$. (2.0 points)
2. Experimentally determine the value of $m \times l$. (2.0 points)

PART-B The mass m of the ball (10.0 points)

Figure 2 shows the MBB fixed horizontally on the rotating stub and a weight attached to one end of a string whose other end is wound on the rotating stub. When the weight falls, the string unwinds, and the MBB rotates. By combining the equation pertinent to this experiment with the one obtained in **PART-A**, you can find an equation for m .

Between the ball and the inner walls of the cylindrical tube acts a frictional force. The physical mechanisms of the friction and the slipping of the ball under the rotational motion are complicated. To simplify the analysis, you may ignore the energy dissipation due to kinetic friction.

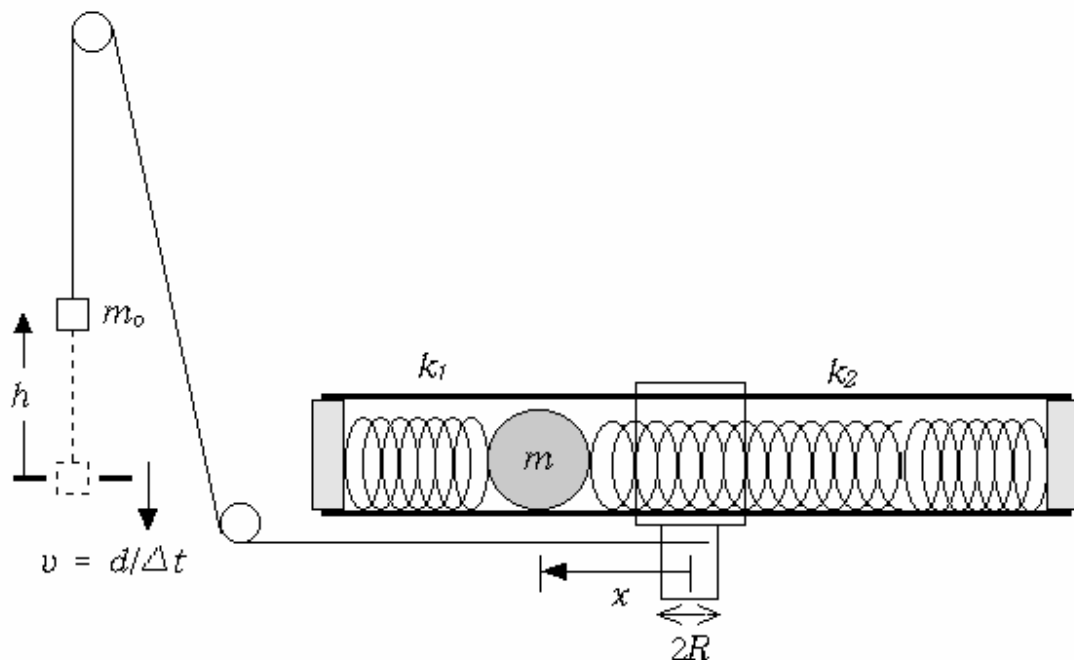

Fig. 2 Rotation of the Mechanical “Black Box” (not to scale)

The angular velocity ω of the MBB can be obtained from the speed v of the weight passing through the Photogate. x is the position of the ball relative to the rotation axis, and d is the length of the weight.

1. Measure the speed of the weight v for various values of downward displacement h of the weight. It is recommended to scan the whole range from $h = 1.0 \times 10^{-2}$ m to 4.0×10^{-1} m by measuring v just once at each h with an interval of $1.0 \times 10^{-2} \sim 2.0 \times 10^{-2}$ m. Plot the data on graph paper in a form that is suitable to find the value of m . After you get a general idea of the relation between v and h , you may repeat the measurement or add some data points, if necessary. When the MBB rotates slowly, the ball does not slip from its static equilibrium position because of the friction between the ball and the tube. When the MBB rotates sufficiently fast, the ball hits and actually stays at the end cap of the tube because the springs are weak. Identify the slow rotation region and the fast rotation region on the graph. (4.0 points)

2. Show your measurements are consistent with the fact that h is proportional to v^2 ($h = C v^2$) in the slow rotation region. Show from your measurements that $h = A v^2 + B$ in the fast rotation region. (1.0 points)

3. The moment of inertia of a ball of radius r and mass m about the axis passing through its center is $2mr^2/5$. If the ball is displaced a distance a perpendicular to the axis, the moment of inertia increases by ma^2 . Use the symbol I to represent the total moment of inertia of all the rotating bodies excluding the ball. Relate the coefficient C to the parameters of the MBB such as m, l , etc. (1.0 points)

4. Relate the coefficients A and B to the parameters of the MBB such as m, l , etc. (1.0 points)

5. Determine the value of m from your measurements and the results obtained in **PART-A**. (3.0 points)

PART-C The spring constants k_1 and k_2 (6.0 points)

In this part, you need to perform small oscillation experiments using the MBB as a rigid pendulum. There are two small holes at each end of the MBB. Two thin pins inserted into the holes can be used as the pivot of small oscillation. The U-shaped support is to be clamped to the stand and used to support the pivot. Note that the angular frequency ω of small oscillation is given as $\omega = [\text{torque}/(\text{moment of inertia} \times \text{angle})]^{1/2}$. Here, the torque and the moment of inertia are with respect to the pivot. Similarly to **PART-B**, consider two experimental conditions, shown in Fig. 3, to avoid the unknown moment of inertia I_0 of the MBB excluding the ball.

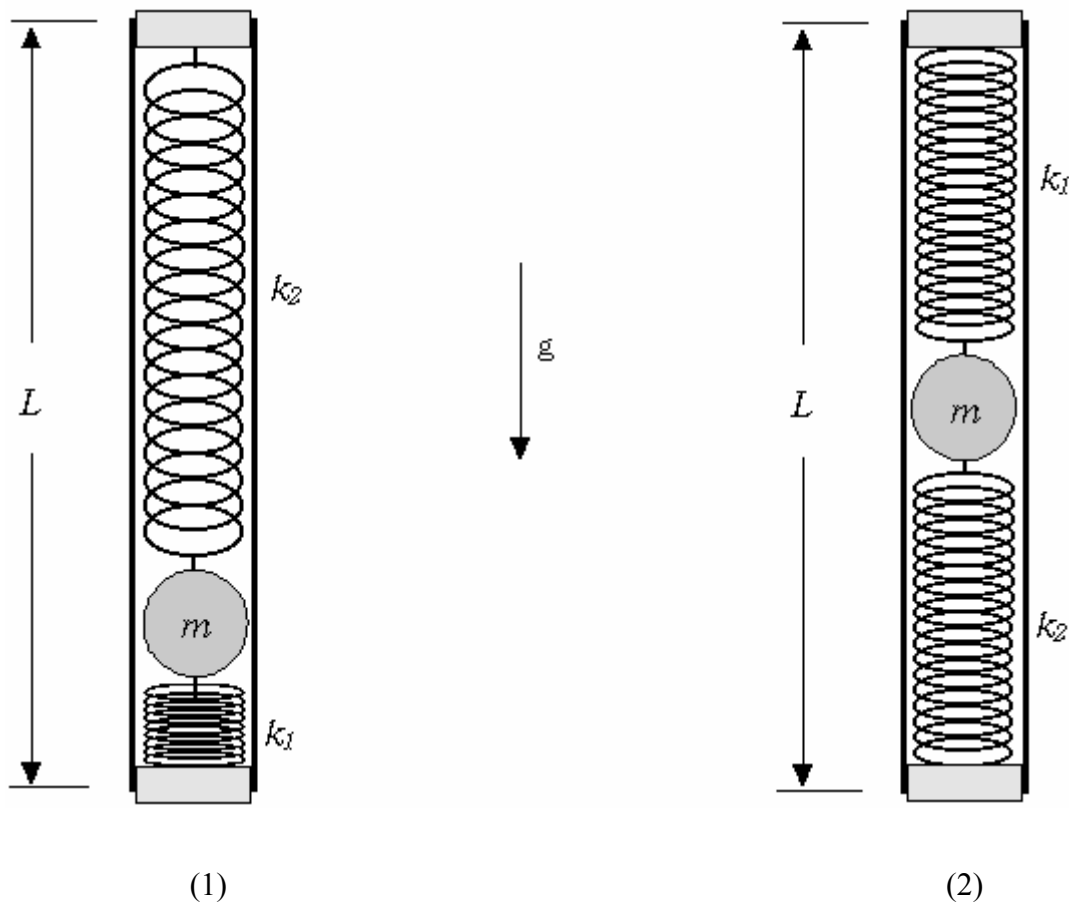

Fig. 3 Oscillation of the Mechanical “Black Box” (not to scale)
The periods of small oscillation, T_1 and T_2 , for two configurations shown above can be measured using the Photogate. Two pins and a U-shaped support are supplied for this experiment.

1. Measure the periods T_1 and T_2 of small oscillation shown in Figs 3(1) and (2) and write down their values, respectively. (1.0 points)
2. Explain (by using equations) why the angular frequencies ω_1 and ω_2 of small oscillation of the configurations are different. Use the symbol I_0 to represent the moment of inertia of the MBB excluding the ball for the axis perpendicular to the MBB at the end. Use the symbol Δl as the displacement of the ball from the horizontal equilibrium position. (1.0 points)
3. Evaluate Δl by eliminating I_0 from the previous results. (1.0 points)
4. By combining the results of **PART-C** 1~3 and **PART-B**, find and write down the value of the effective total spring constant k of the two-spring system. (2.0 points)
5. Obtain the respective values of k_1 and k_2 . Write down their values. (1.0 points)

Country Code	Student Code

Answer Form

PART-A

1. Suggest and justify, by using equations, a method allowing to obtain $m \times l$. (2.0 points)

2. Experimentally determine the value of $m \times l$. (2.0 points)

$m \times l =$ _____ .

Country Code	Student Code

PART-B

1. Measure ν for various values of h . Plot the data on a graph paper in a form that is suitable to find the value of m . Identify the slow rotation region and the fast rotation region on the graph. (4.0 points)

(On a separate graph paper)

2. Show from your measurements that $h = C\nu^2$ in the slow rotation region, and $h = A\nu^2 + B$ in the fast rotation region. (1.0 points)

(In the plot above)

3. Relate the coefficient C to the parameters of the MBB. (1.0 points)

Country Code	Student Code

4. Relate the coefficients A and B to the parameters of the MBB. (1.0 points)

Country Code	Student Code

5. Determine the value of m from your measurements and the results obtained in **PART-A**. (3.0 points)

$m =$ _____ .

Country Code	Student Code

PART-C

1. Measure the periods T_1 and T_2 of small oscillation shown in Figs. 3 (1) and (2) and write down their values, respectively. (1.0 points)

$T_1 =$ _____ .

$T_2 =$ _____ .

2. Explain, by using equations, why the angular frequencies ω_1 and ω_2 of small oscillation of the configurations are different. (1.0 points)

Country Code	Student Code

3. Evaluate Δl by eliminating I_0 from the previous results. (1.0 points)

$\Delta l =$ _____ .

Country Code	Student Code

4. Write down the value of the effective total spring constant k of the two-spring system. (2.0 points)

$k =$ _____ .

5. Obtain the respective values of k_1 and k_2 . Write down their values. (1.0 points)

$k_1 =$ _____ .

$k_2 =$ _____ .

Theoretical Question 1: Ping-Pong Resistor

1. Answers

$$(a) \quad F_R = -\frac{1}{2} \pi R^2 \epsilon_0 \frac{V^2}{d^2}$$

$$(b) \quad \chi = -\epsilon_0 \frac{\pi r^2}{d}$$

$$(c) \quad V_{\text{th}} = \sqrt{\frac{2mgd}{\chi}}$$

$$(d) \quad v_s = \sqrt{\alpha V^2 + \beta}$$

$$\alpha = \left(\frac{\eta^2}{1-\eta^2} \right) \left(\frac{2\chi}{m} \right), \quad \beta = \left(\frac{\eta^2}{1+\eta^2} \right) (2gd)$$

$$(e) \quad \gamma = \sqrt{\frac{1+\eta}{1-\eta}} \sqrt{\frac{\chi^3}{2md^2}}$$

$$(f) \quad V_c = \sqrt{\frac{1-\eta^2}{1+\eta^2}} \sqrt{\frac{mgd}{\chi}}, \quad I_c = \frac{2\eta\sqrt{1-\eta^2}}{(1+\eta)(1+\eta^2)} g\sqrt{m\chi}$$

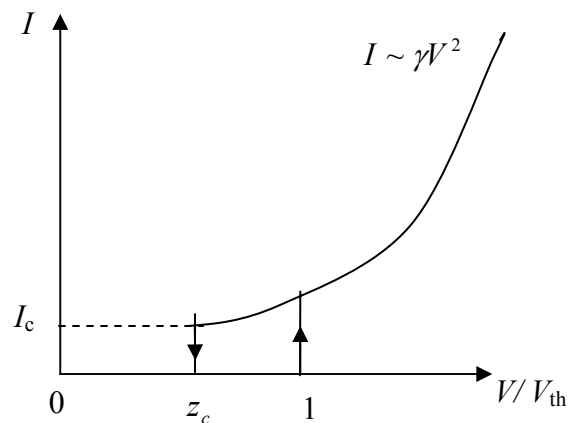

2. Solutions

(a) [1.2 points]

The charge Q induced by the external bias voltage V can be obtained by applying the Gauss law:

$$\varepsilon_0 \oint \vec{E} \cdot d\vec{s} = Q \quad (\text{a1})$$

$$Q = \varepsilon_0 E \cdot (\pi R^2) = \varepsilon_0 \left(\frac{V}{d} \right) \cdot (\pi R^2), \quad (\text{a2})$$

where $V = Ed$.

The energy stored in the capacitor:

$$U = \int_0^V Q(V') dV' = \int_0^V \varepsilon_0 \pi R^2 \left(\frac{V'}{d} \right) dV' = \frac{1}{2} \varepsilon_0 \pi R^2 \frac{V^2}{d}. \quad (\text{a3})$$

The force acting on the plate, when the bias voltage V is kept constant:

$$\therefore F_R = + \frac{\partial U}{\partial d} = - \frac{1}{2} \varepsilon_0 \pi R^2 \frac{V^2}{d^2}. \quad (\text{a4})$$

[An alternative solution:]

Since the electric field E' acting on one plate should be generated by the other plate and its magnitude is

$$E' = \frac{1}{2} E = \frac{V}{2d}, \quad (\text{a5})$$

the force acting on the plate can be obtained by

$$F_R = QE'. \quad (\text{a6})$$

(b) [0.8 points]

The charge q on the small disk can also be calculated by applying the Gauss law:

$$\varepsilon_0 \oint \vec{E} \cdot d\vec{s} = q. \quad (\text{b1})$$

Since one side of the small disk is in contact with the plate,

$$q = -\varepsilon_0 E \cdot (\pi r^2) = -\varepsilon_0 \frac{\pi r^2}{d} V = \chi V. \quad (\text{b2})$$

Alternatively, one may use the area ratio for $q = -\left(\frac{\pi r^2}{\pi R^2}\right)Q$.

$$\therefore \chi = -\varepsilon_0 \frac{\pi r^2}{d}. \quad (\text{b3})$$

(c) [0.5 points]

The net force, F_{net} , acting on the small disk should be a sum of the gravitational and electrostatic forces:

$$F_{\text{net}} = F_g + F_e. \quad (\text{c1})$$

The gravitational force: $F_g = -mg$.

The electrostatic force can be derived from the result of (a) above:

$$F_e = \frac{1}{2} \varepsilon_0 \frac{\pi r^2}{d^2} V^2 = \frac{\chi}{2d} V^2. \quad (\text{c2})$$

In order for the disk to be lifted, one requires $F_{\text{net}} > 0$:

$$\frac{\chi}{2d} V^2 - mg > 0. \quad (\text{c3})$$

$$\therefore V_{\text{th}} = \sqrt{\frac{2mgd}{\chi}}. \quad (\text{c4})$$

(d) [2.3 points]

Let v_s be the steady velocity of the small disk just after its collision with the bottom plate. Then the *steady-state* kinetic energy K_s of the disk just above the bottom plate is given by

$$K_s = \frac{1}{2} m v_s^2. \quad (\text{d1})$$

For each round trip, the disk gains electrostatic energy by

$$\Delta U = 2qV. \quad (\text{d2})$$

For each inelastic collision, the disk lose its kinetic energy by

$$\Delta K_{\text{loss}} = K_{\text{before}} - K_{\text{after}} = (1 - \eta^2) K_{\text{before}} = \left(\frac{1}{\eta^2} - 1\right) K_{\text{after}}. \quad (\text{d3})$$

Since K_s is the energy after the collision at the bottom plate and $(K_s + qV - mgd)$ is

the energy before the collision at the top plate, the total energy loss during the round trip can be written in terms of K_s :

$$\Delta K_{\text{tot}} = \left(\frac{1}{\eta^2} - 1 \right) K_s + (1 - \eta^2)(K_s + qV - mgd). \quad (\text{d4})$$

In its steady state, ΔU should be compensated by ΔK_{tot} .

$$2qV = \left(\frac{1}{\eta^2} - 1 \right) K_s + (1 - \eta^2)(K_s + qV - mgd). \quad (\text{d5})$$

Rearranging Eq. (d5), we have

$$\begin{aligned} K_s &= \frac{\eta^2}{1 - \eta^4} \left[(1 + \eta^2)qV + (1 - \eta^2)mgd \right] \\ &= \left(\frac{\eta^2}{1 - \eta^2} \right) qV + \left(\frac{\eta^2}{1 + \eta^2} \right) mgd \\ &= \frac{1}{2} m v_s^2. \end{aligned} \quad (\text{d6})$$

Therefore,

$$v_s = \sqrt{\left(\frac{\eta^2}{1 - \eta^2} \right) \left(\frac{2qV^2}{m} \right) + \left(\frac{\eta^2}{1 + \eta^2} \right) (2gd)}. \quad (\text{d7})$$

Comparing with the form:

$$v_s = \sqrt{\alpha V^2 + \beta}, \quad (\text{d8})$$

$$\alpha = \left(\frac{\eta^2}{1 - \eta^2} \right) \left(\frac{2q}{m} \right), \quad \beta = \left(\frac{\eta^2}{1 + \eta^2} \right) (2gd). \quad (\text{d9})$$

[An alternative solution:]

Let v_n be the velocity of the small disk just after n -th collision with the bottom plate.

Then the kinetic energy of the disk just above the bottom plate is given by

$$K_n = \frac{1}{2} m v_n^2. \quad (\text{d10})$$

When it reaches the top plate, the disk gains energy by the increase of potential energy:

$$\Delta U_{\text{up}} = qV - mgd. \quad (\text{d11})$$

Thus, the kinetic energy just before its collision with the top plate becomes

$$K_{n-\text{up}} = \frac{1}{2} m v_{\text{up}}^2 = K_n + \Delta U_{\text{up}}. \quad (\text{d12})$$

Since $\eta = v_{\text{after}} / v_{\text{before}}$, the kinetic energy after the collision with the top plate becomes scaled down by a factor of η^2 :

$$K'_{n\text{-up}} = \eta^2 \cdot K_{n\text{-up}}. \quad (\text{d13})$$

Now the potential energy gain by the downward motion is:

$$\Delta U_{\text{down}} = qV + mgd \quad (\text{d14})$$

so that the kinetic energy just before it collides with the bottom plate becomes:

$$K_{n\text{-down}} = K'_{n\text{-up}} + \Delta U_{\text{down}}. \quad (\text{d15})$$

Again, due to the loss of energy by the collision with the bottom plate, the kinetic energy after its $(n+1)$ -th collision can be obtained by

$$\begin{aligned} K_{n+1} &= \eta^2 \cdot K_{n\text{-down}} \\ &= \eta^2 (K'_{n\text{-up}} + \Delta U_{\text{down}}) \\ &= \eta^2 (\eta^2 (K_n + \Delta U_{\text{up}}) + \Delta U_{\text{down}}) \\ &= \eta^2 (\eta^2 (K_n + qV - mgd) + qV + mgd) \\ &= \eta^4 K_n + \eta^2 (1 + \eta^2) qV + \eta^2 (1 - \eta^2) mgd. \end{aligned} \quad (\text{d16})$$

As $n \rightarrow \infty$, we expect the velocity $v_n \rightarrow v_s$, that is, $K_n \rightarrow K_s = \frac{1}{2} m v_s^2$:

$$\begin{aligned} K_s &= \frac{1}{1 - \eta^4} [\eta^2 (1 + \eta^2) qV + \eta^2 (1 - \eta^2) mgd] \\ &= \left(\frac{\eta^2}{1 - \eta^2} \right) qV + \left(\frac{\eta^2}{1 + \eta^2} \right) mgd \\ &= \frac{1}{2} m v_s^2 \end{aligned} \quad (\text{d17})$$

(e) [2.2 points]

The amount of charge carried by the disk during its round trip between the plates is $\Delta Q = 2q$, and the time interval $\Delta t = t_+ + t_-$, where t_+ (t_-) is the time spent during the up- (down-) ward motion respectively.

Here t_+ (t_-) can be determined by

$$\begin{aligned} v_{0+} t_+ + \frac{1}{2} a_+ t_+^2 &= d \\ v_{0-} t_- + \frac{1}{2} a_- t_-^2 &= d \end{aligned} \quad (\text{e1})$$

where v_{0+} (v_{0-}) is the initial velocity at the bottom (top) plate and a_+ (a_-) is the up-

(down-) ward acceleration respectively.

Since the force acting on the disk is given by

$$F = ma_{\pm} = qE \mp mg = \frac{qV}{d} \mp mg, \quad (\text{e2})$$

in the limit of $mgd \ll qV$, a_{\pm} can be approximated by

$$a_0 = a_+ = a_- \approx \frac{qV}{md}, \quad (\text{e3})$$

which implies that the upward and down-ward motion should be symmetric. Thus, Eq.(e1) can be described by a single equation with $t_0 = t_+ = t_-$, $v_s = v_{0+} = v_{0-}$, and $a_0 = a_+ = a_-$. Moreover, since the speed of the disk just after the collision should be the same for the top- and bottom-plates, one can deduce the relation:

$$v_s = \eta(v_s + a_0 t_0), \quad (\text{e4})$$

from which we obtain the time interval $\Delta t = 2t_0$,

$$\Delta t = 2t_0 = 2 \left(\frac{1-\eta}{\eta} \right) \frac{v_s}{a_0}. \quad (\text{e5})$$

From Eq. (d6), in the limit of $mgd \ll qV$, we have

$$K_s = \frac{1}{2} m v_s^2 \approx \left(\frac{\eta^2}{1-\eta^2} \right) qV. \quad (\text{e6})$$

By substituting the results of Eqs. (e3) and (e6), we get

$$\Delta t = 2 \left(\frac{1-\eta}{\eta} \right) \sqrt{\frac{2\eta^2}{1-\eta^2}} \sqrt{\frac{md^2}{qV}} = 2 \sqrt{\frac{1-\eta}{1+\eta}} \sqrt{\frac{2md^2}{\chi V^2}}. \quad (\text{e7})$$

Therefore, from $I = \frac{\Delta Q}{\Delta t} = \frac{2q}{\Delta t}$,

$$I = \frac{2q}{\Delta t} = \chi V \sqrt{\frac{1+\eta}{1-\eta}} \sqrt{\frac{\chi V^2}{2md^2}} = \sqrt{\frac{1+\eta}{1-\eta}} \sqrt{\frac{\chi^3}{2md^2}} V^2. \quad (\text{e8})$$

$$\therefore \gamma = \sqrt{\frac{1+\eta}{1-\eta}} \sqrt{\frac{\chi^3}{2md^2}} \quad (\text{e9})$$

[Alternative solution #1:]

Starting from Eq. (e3), we can solve the quadratic equation of Eq. (e1) so that

$$t_{\pm} = \frac{v_{0\pm}}{a_0} \left(\sqrt{1 + \frac{2da_0}{v_{0\pm}^2}} - 1 \right). \quad (\text{e10})$$

When it reaches the steady state, the initial velocities $v_{0\pm}$ are given by

$$v_{0+} = v_s \quad (\text{e11})$$

$$v_{0-} = \eta \cdot (v_s + a_0 t_+) = \eta v_s \sqrt{1 + \frac{2da_0}{v_s^2}}, \quad (\text{e12})$$

where v_s can be rewritten by using the result of Eq. (e6),

$$v_s^2 \approx \alpha V = \left(\frac{\eta^2}{1-\eta^2} \right) \frac{2qV}{m} = \left(\frac{\eta^2}{1-\eta^2} \right) 2a_0 d. \quad (\text{e13})$$

As a result, we get $v_{0-} \cong \eta v_s \cdot \frac{1}{\eta} = v_s$ and consequently $t_{\pm} = \frac{v_s}{a_0} \left(\frac{1}{\eta} - 1 \right)$, which is equivalent to Eq. (e4).

[Alternative solution #2:]

The current I can be obtained from

$$I = \frac{2q}{\Delta t} = \frac{2q\bar{v}}{d}, \quad (\text{e14})$$

where \bar{v} is an average velocity. Since the up and down motions are symmetric with the same constant acceleration in the limit of $mgd \ll qV$,

$$\bar{v} = \frac{1}{2} \left(v_s + \frac{v_s}{\eta} \right). \quad (\text{e15})$$

Thus, we have

$$I = \frac{q}{2d} \left(1 + \frac{1}{\eta} \right) v_s. \quad (\text{e16})$$

Inserting the expression (Eq. (e15)) of v_s into Eq. (e16), one obtains an expression identical to Eq. (e8).

(f) [3 points]

The disk will lose its kinetic energy and eventually cease to move when the disk can not reach the top plate. In other words, the threshold voltage V_c can be determined from the condition that the velocity v_{0-} of the disk at the top plate is zero, i.e., $v_{0-} = 0$.

In order for the disk to have $v_{0-} = 0$ at the top plate, the kinetic energy \bar{K}_s at the

top plate should satisfy the relation:

$$\bar{K}_s = K_s + qV_c - mgd = 0, \quad (\text{f1})$$

where K_s is the *steady-state* kinetic energy at the bottom plate after the collision.

Therefore, we have

$$\left(\frac{\eta^2}{1-\eta^2}\right)qV_c + \left(\frac{\eta^2}{1+\eta^2}\right)mgd + qV_c - mgd = 0, \quad (\text{f2})$$

or equivalently,

$$(1+\eta^2)qV_c - (1-\eta^2)mgd = 0. \quad (\text{f3})$$

$$\therefore qV_c = \frac{1-\eta^2}{1+\eta^2}mgd \quad (\text{f4})$$

From the relation $q = \chi V_c$,

$$\therefore V_c = \sqrt{\frac{1-\eta^2}{1+\eta^2}} \sqrt{\frac{mgd}{\chi}}. \quad (\text{f5})$$

In comparison with the threshold voltage V_{th} of Eq. (c4), we can rewrite Eq. (f5) by

$$V_c = z_c V_{\text{th}} \quad (\text{f6})$$

where z_c should be used in the plot of I vs. (V/V_{th}) and

$$z_c = \sqrt{\frac{1-\eta^2}{2(1+\eta^2)}}. \quad (\text{f7})$$

[Note that an alternative derivation of Eq. (f1) is possible if one applies the energy compensation condition of Eq. (d5) or the recursion relation of Eq. (d17) at the top plate instead of the bottom plate.]

Now we can setup equations to determine the time interval $\Delta t = t_- + t_+$:

$$v_{0-}t_- + \frac{1}{2}a_-t_-^2 = d \quad (\text{f8})$$

$$v_{0+}t_+ + \frac{1}{2}a_+t_+^2 = d \quad (\text{f9})$$

where the accelerations are given by

$$a_+ = \frac{qV_c}{md} - g = \left[\frac{1-\eta^2}{1+\eta^2} - 1\right]g = \left(\frac{-2\eta^2}{1+\eta^2}\right)g \quad (\text{f10})$$

$$a_- = \frac{qV_c}{md} + g = \left[\frac{1-\eta^2}{1+\eta^2} + 1 \right] g = \left(\frac{2}{1+\eta^2} \right) g \quad (\text{f11})$$

$$\frac{a_+}{a_-} = -\eta^2 \quad (\text{f12})$$

Since $v_{0-} = 0$, we have $v_{0+} = \eta(a_- t_-)$ and $t_-^2 = 2d/a_-$.

$$t_- = \sqrt{\frac{2d}{a_-}} = \sqrt{(1+\eta^2) \left(\frac{d}{g} \right)}, \quad (\text{f13})$$

By using $v_{0+}^2 = \eta^2(2da_-) = -2da_+$, we can solve the quadratic equation of Eq. (f9):

$$t_+ = \frac{v_{0+}}{a_+} \left(\sqrt{1 + \frac{2da_+}{v_{0+}^2}} - 1 \right) = -\frac{v_{0+}}{a_+} = \sqrt{\frac{2d}{|a_+|}} = \sqrt{\left(\frac{1+\eta^2}{\eta^2} \right) \left(\frac{d}{g} \right)} = \frac{t_-}{\eta}. \quad (\text{f14})$$

$$\therefore \Delta t = t_- + t_+ = \left(1 + \frac{1}{\eta} \right) \sqrt{(1+\eta^2) \left(\frac{d}{g} \right)} \quad (\text{f15})$$

$$I_c = \frac{\Delta Q_c}{\Delta t} = \frac{2q}{\Delta t} = \frac{2\chi V_c}{\Delta t} = \frac{2\eta\sqrt{1-\eta^2}}{(1+\eta)(1+\eta^2)} g\sqrt{m\chi}. \quad (\text{f16})$$

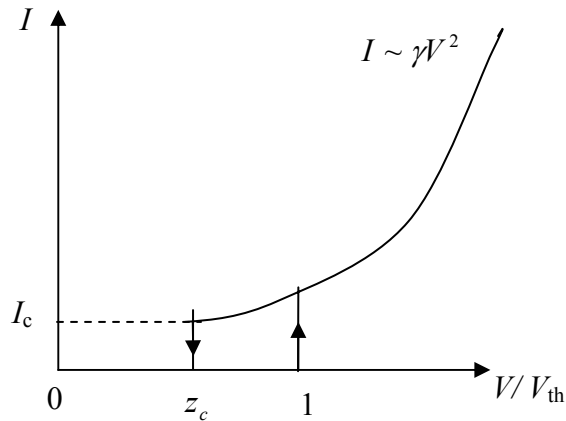

[A more elaborate Solution:]

One may find a general solution for an arbitrary value of V . By solving the quadratic equations of Eqs. (f8) and (f9), we have

$$t_{\pm} = \frac{v_{0\pm}}{a_{\pm}} \left[-1 + \sqrt{1 + \frac{2da_{\pm}}{v_{0\pm}^2}} \right]. \quad (\text{f17})$$

(It is noted that one has to keep the smaller positive root.)

To simplify the notation, we introduce a few variables:

$$(i) \quad y = \frac{V}{V_{\text{th}}} \quad \text{where} \quad V_{\text{th}} = \sqrt{\frac{2mgd}{\chi}},$$

$$(ii) \quad z_c = \sqrt{\frac{1-\eta^2}{2(1+\eta^2)}}, \quad \text{which is defined in Eq. (f7),}$$

$$(iii) \quad w_0 = 2\eta\sqrt{\frac{gd}{1-\eta^2}} \quad \text{and} \quad w_1 = 2\sqrt{\frac{d}{(1-\eta^2)g}},$$

In terms of y , w , and z_c ,

$$a_+ = \frac{qV}{md} - g = g(2y^2 - 1) \quad (\text{f18})$$

$$a_- = \frac{qV}{md} + g = g(2y^2 + 1) \quad (\text{f19})$$

$$v_{0+} = v_s = w_0\sqrt{y^2 + z_c^2} \quad (\text{f20})$$

$$v_{0-} = \eta(v_s + a_+t_+) = w_0\sqrt{y^2 - z_c^2} \quad (\text{f21})$$

$$t_+ = w_1 \frac{\sqrt{y^2 - z_c^2} - \eta\sqrt{y^2 + z_c^2}}{2y^2 - 1} \quad (\text{f22})$$

$$t_- = w_1 \frac{\sqrt{y^2 + z_c^2} - \eta\sqrt{y^2 - z_c^2}}{2y^2 + 1} \quad (\text{f21})$$

$$I = \frac{\Delta Q}{\Delta t} = \frac{2q}{t_+ + t_-} = (2\chi V_{th}) \frac{y}{\Delta t} = \frac{\sqrt{8mgd\chi}}{w_1} F(y) \quad (\text{f22})$$

where

$$F(y) = y \left\{ \frac{\sqrt{y^2 - z_c^2} - \eta \sqrt{y^2 + z_c^2}}{2y^2 - 1} + \frac{\sqrt{y^2 + z_c^2} - \eta \sqrt{y^2 - z_c^2}}{2y^2 + 1} \right\}^{-1} \quad (\text{f23})$$

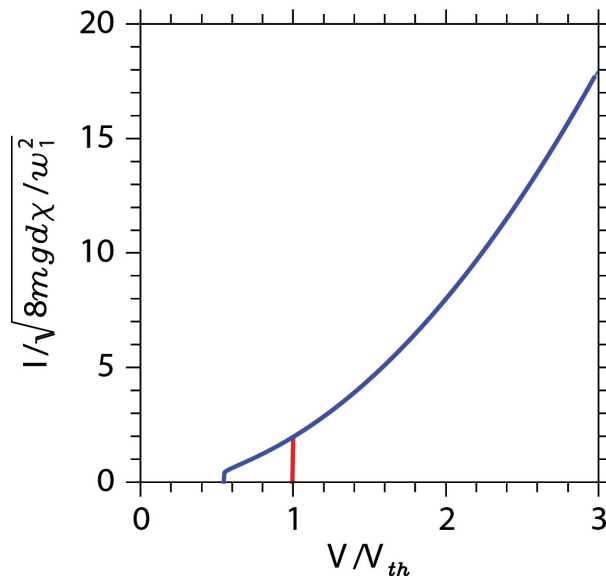

3. Mark Distribution

No.	Total Pt.	Partial Pt.	Contents	
(a)	1.2	0.3	Gauss law, or a formula for the capacitance of a parallel plate	
		0.5	Total energy of a capacitor at V	E' = electrical field by the other plate
		0.4	Force from the energy expression	$F = QE'$
(b)	0.8	0.3	Gauss law	Use of area ratio and result of (a)
		0.5	Correct answer	
(c)	0.5	0.1	Correct lift-up condition with force balance	
		0.2	Use of area ratio and result of (a)	
		0.2	Correct answer	
(d)	2.3	0.5	Energy conservation and the work done by the field	
		0.5	Loss of energy due to collisions	
		0.8	Condition for the steady state: energy balance equation (loss = gain)	Condition for the steady state: recursion relation
		0.5	Correct answer	
(e)	2.2	0.2	$\Delta Q = 2q$ per trip	
		0.5	Acceleration a_{\pm} in the limit of $qV \gg mgd$; $a_+ = a_-$ by symmetry	
		0.3	Kinetic equations for d , v , a , and t , solutions for t_+	By using the symmetry, derive the relation (e4)
		0.4	Expression of $v_{0\pm}$ and t_{\pm} in its steady state	
		0.4	Solutions of t_{\pm} in approximation	
		0.4	Correct answer	
(f)	3.0	0.5	Condition for V_c ; $K_{up} = 0$ or $v_{s,up} = 0$	Using (d8), Recursion relations
		0.3	energy balance equation	
		0.3	Correct answer of V_c	
		0.7	Kinetic equations for Δt	
		0.3	Correct answer of I_c	
		0.9	Distinction between V_{th} and V_c^2 the asymptotic behavior $I = \gamma V^2$ in plots	
Total	10			

Theoretical Question 2: *Rising Balloon*

1. Answers

$$(a) F_B = M_A n g \frac{P}{P + \Delta P}$$

$$(b) \gamma = \frac{\rho_0 z_0 g}{P_0} = 5.5$$

$$(c) \Delta P = \frac{4\kappa RT}{r_0} \left(\frac{1}{\lambda} - \frac{1}{\lambda^7} \right)$$

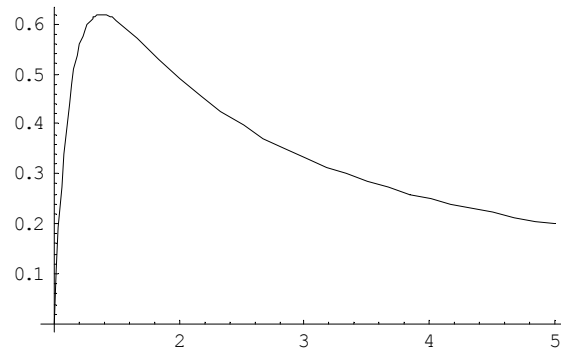

$$(d) a = 0.110$$

$$(e) z_f = 11 \text{ km}, \quad \lambda_f = 2.1.$$

2. Solutions

[Part A]

(a) [1.5 points]

Using the ideal gas equation of state, the volume of the helium gas of n moles at pressure $P + \Delta P$ and temperature T is

$$V = nRT / (P + \Delta P) \quad (\text{a1})$$

while the volume of n' moles of air gas at pressure P and temperature T is

$$V = n'RT / P. \quad (\text{a2})$$

Thus the balloon displaces $n' = n \frac{P}{P + \Delta P}$ moles of air whose weight is $M_A n' g$.

This displaced air weight is the buoyant force, i.e.,

$$F_B = M_A n g \frac{P}{P + \Delta P}. \quad (\text{a3})$$

(Partial credits for subtracting the gas weight.)

(b) [2 points]

The pressure difference arising from a height difference of z is $-\rho g z$ when the air density ρ is a constant. When it varies as a function of the height, we have

$$\frac{dP}{dz} = -\rho g = -\frac{\rho_0 T_0}{P_0} \frac{P}{T} g \quad (\text{b1})$$

where the ideal gas law $\rho T / P = \text{constant}$ is used. Inserting Eq. (2.1) and $T / T_0 = 1 - z / z_0$ on both sides of Eq. (b1), and comparing the two, one gets

$$\gamma = \frac{\rho_0 z_0 g}{P_0} = \frac{1.16 \times 4.9 \times 10^4 \times 9.8}{1.01 \times 10^5} = 5.52. \quad (\text{b2})$$

The required numerical value is 5.5.

[Part B]

(c) [2 points]

The work needed to increase the radius from r to $r + dr$ under the pressure difference ΔP is

$$dW = 4\pi r^2 \Delta P dr, \quad (\text{c1})$$

while the increase of the elastic energy for the same change of r is

$$dW = \left(\frac{dU}{dr} \right) dr = 4\pi\kappa RT \left(4r - 4 \frac{r_0^6}{r^5} \right) dr . \quad (c2)$$

Equating the two expressions of dW , one gets

$$\Delta P = 4\kappa RT \left(\frac{1}{r} - \frac{r_0^6}{r^7} \right) = \frac{4\kappa RT}{r_0} \left(\frac{1}{\lambda} - \frac{1}{\lambda^7} \right) . \quad (c3)$$

This is the required answer.

The graph as a function of λ (>1) increases sharply initially, has a maximum at $\lambda = 7^{1/6} = 1.38$, and decreases as λ^{-1} for large λ . The plot of $\Delta P / (4\kappa RT / r_0)$ is given below.

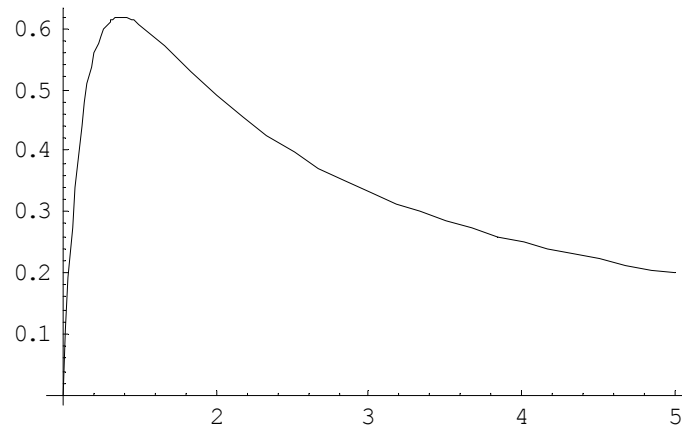

(d) [1.5 points]

From the ideal gas law,

$$P_0 V_0 = n_0 R T_0 \quad (d1)$$

where V_0 is the unstretched volume.

At volume $V = \lambda^3 V_0$ containing n moles, the ideal gas law applied to the gas inside at $T = T_0$ gives the inside pressure P_{in} as

$$P_{\text{in}} = n R T_0 / V = \frac{n}{n_0 \lambda^3} P_0 . \quad (d2)$$

On the other hand, the result of (c) at $T = T_0$ gives

$$P_{\text{in}} = P_0 + \Delta P = P_0 + \frac{4\kappa R T_0}{r_0} \left(\frac{1}{\lambda} - \frac{1}{\lambda^7} \right) = \left(1 + a \left(\frac{1}{\lambda} - \frac{1}{\lambda^7} \right) \right) P_0 . \quad (d3)$$

Equating (d2) and (d3) to solve for a ,

$$a = \frac{n/(n_0\lambda^3) - 1}{\lambda^{-1} - \lambda^{-7}}. \quad (\text{d5})$$

Inserting $n/n_0=3.6$ and $\lambda=1.5$ here, $a=0.110$.

[Part C]

(e) [3 points]

The buoyant force derived in problem (a) should balance the total mass of $M_T=1.12$ kg.

Thus, from Eq. (a3), at the weight balance,

$$\frac{P}{P + \Delta P} = \frac{M_T}{M_A n}. \quad (\text{e1})$$

On the other hand, applying again the ideal gas law to the helium gas inside of volume

$V = \frac{4}{3}\pi r^3 = \lambda^3 \frac{4}{3}\pi r_0^3 = \lambda^3 V_0$, for arbitrary ambient P and T , one has

$$(P + \Delta P)\lambda^3 = \frac{nRT}{V_0} = P_0 \frac{T}{T_0} \frac{n}{n_0} \quad (\text{e2})$$

for n moles of helium. Eqs. (c3), (e1), and (e2) determine the three unknowns P , ΔP , and λ as a function of T and other parameters. Using Eq. (e2) in Eq. (e1), one has an alternative condition for the weight balance as

$$\frac{P}{P_0} \frac{T_0}{T} \lambda^3 = \frac{M_T}{M_A n_0}. \quad (\text{e3})$$

Next using (c3) for ΔP in (e2), one has

$$P\lambda^3 + \frac{4\kappa RT}{r_0} \lambda^2 (1 - \lambda^{-6}) = P_0 \frac{T}{T_0} \frac{n}{n_0}$$

or, rearranging it,

$$\frac{P}{P_0} \frac{T_0}{T} \lambda^3 = \frac{n}{n_0} - a\lambda^2 (1 - \lambda^{-6}), \quad (\text{e4})$$

where the definition of a has been used again.

Equating the right hand sides of Eqs. (e3) and (e4), one has the equation for λ as

$$\lambda^2 (1 - \lambda^{-6}) = \frac{1}{an_0} \left(n - \frac{M_T}{M_A} \right) = 4.54. \quad (\text{e5})$$

The solution for λ can be obtained by

$$\lambda^2 \approx 4.54 / (1 - 4.54^{-3}) \approx 4.54: \lambda_f \cong 2.13. \quad (\text{e6})$$

To find the height, replace $(P/P_0)/(T/T_0)$ on the left hand side of Eq. (e3) as a function of the height given in (b) as

$$\frac{P}{P_0} \frac{T_0}{T} \lambda^3 = (1 - z_f / z_0)^{\gamma-1} \lambda_f^3 = \frac{M_T}{M_A n_0} = 3.10 . \quad (\text{e7})$$

Solution of Eq. (e7) for z_f with $\lambda_f = 2.13$ and $\gamma - 1 = 4.5$ is

$$z_f = 49 \times \left(1 - (3.10 / 2.13^3)^{1/4.5} \right) = 10.9 \text{ (km)}. \quad (\text{e8})$$

The required answers are $\lambda_f = 2.1$, and $z_f = 11 \text{ km}$.

3. Mark Distribution

No.	Total Pt.	Partial Pt.	Contents
(a)	1.5	0.5	Archimedes' principle
		0.5	Ideal gas law applied correctly
		0.5	Correct answer (partial credits 0.3 for subtracting He weight)
(b)	2.0	0.8	Relation of pressure difference to air density
		0.5	Application of ideal gas law to convert the density into pressure
		0.5	Correct formula for γ
		0.2	Correct number in answer
(c)	2.0	0.7	Relation of mechanical work to elastic energy change
		0.3	Relation of pressure to force
		0.5	Correct answer in formula
		0.5	Correct sketch of the curve
(d)	1.5	0.3	Use of ideal gas law for the increased pressure inside
		0.4	Expression of inside pressure in terms of a at the given conditions
		0.5	Formula or correct expression for a
		0.3	Correct answer
(e)	3.0	0.3	Use of force balance as one condition to determine unknowns
		0.3	Ideal gas law applied to the gas as an independent condition to determine unknowns
		0.5	The condition to determine λ_f numerically
		0.7	Correct answer for λ_f
		0.5	The relation of z_f versus λ_f
		0.7	Correct answer for z_f
Total	10		

Theoretical Question 3: *Scanning Probe Microscope*

1. Answers

$$(a) \quad A = \frac{F_0}{\sqrt{m^2(\omega_0^2 - \omega^2)^2 + b^2\omega^2}} \quad \text{and} \quad \tan\phi = \frac{b\omega_0}{m(\omega_0^2 - \omega^2)}. \quad \text{At } \omega = \omega_0, \quad A = \frac{F_0}{b\omega_0}$$

$$\text{and } \phi = \frac{\pi}{2}.$$

(b) A non-vanishing dc component exists only when $\omega = \omega_i$.

In this case the amplitude of the dc signal will be $\frac{1}{2}V_{i0}V_{R0} \cos\phi_i$.

$$(c) \quad \frac{c_1 c_2}{2} \frac{V_{R0}^2}{b\omega_0} \quad \text{at the resonance frequency } \omega_0.$$

$$(d) \quad \Delta m = 1.7 \times 10^{-18} \text{ kg}.$$

$$(e) \quad \omega'_0 = \omega_0 \left(1 - \frac{c_3}{m\omega_0^2} \right)^{1/2}.$$

$$(f) \quad d_0 = \left(k_e \frac{qQ}{m\omega_0 \Delta\omega_0} \right)^{1/3}$$

$$d_0 = 41 \text{ nm}.$$

2. Solutions

(a) [1.5 points]

Substituting $z(t) = A \sin(\omega t - \phi)$ in the equation $m \frac{d^2 z}{dt^2} + b \frac{dz}{dt} + m \omega_0^2 z = F_0 \sin \omega t$ yields,

$$-m \omega^2 \sin(\omega t - \phi) + b \omega \cos(\omega t - \phi) + m \omega_0^2 \sin(\omega t - \phi) = \frac{F_0}{A} \sin \omega t. \quad (\text{a1})$$

Collecting terms proportional to $\sin \omega t$ and $\cos \omega t$, one obtains

$$\left\{ m(\omega_0^2 - \omega^2) \cos \phi + b \omega \sin \phi - \frac{F_0}{A} \right\} \sin \omega t + \left\{ -m(\omega_0^2 - \omega^2) \sin \phi + b \omega \cos \phi \right\} \cos \omega t = 0 \quad (\text{a2})$$

Zeroing the each curly square bracket produces

$$\tan \phi = \frac{b \omega}{m(\omega_0^2 - \omega^2)}, \quad (\text{a3})$$

$$A = \frac{F_0}{\sqrt{m^2 (\omega_0^2 - \omega^2)^2 + b^2 \omega^2}}. \quad (\text{a4})$$

At $\omega = \omega_0$,

$$A = \frac{F_0}{b \omega_0} \quad \text{and} \quad \phi = \frac{\pi}{2}. \quad (\text{a5})$$

(b) [1 point]

The multiplied signal is

$$\begin{aligned} & V_{i0} \sin(\omega_i t - \phi_i) V_{R0} \sin(\omega t) \\ &= \frac{1}{2} V_{i0} V_{R0} [\cos\{(\omega_i - \omega)t - \phi_i\} - \cos\{(\omega_i + \omega)t - \phi_i\}] \end{aligned} \quad (\text{b1})$$

A non-vanishing dc component exists only when $\omega = \omega_i$. In this case the amplitude of the dc signal will be

$$\frac{1}{2} V_{i0} V_{R0} \cos \phi_i. \quad (\text{b2})$$

(c) [1.5 points]

Since the lock-in amplifier measures the ac signal of the same frequency with its reference signal, the frequency of the piezoelectric tube oscillation, the frequency of the

cantilever, and the frequency of the photodiode detector should be same. The magnitude of the input signal at the resonance is

$$V_{i0} = c_2 \frac{F_0}{b\omega_0} = \frac{c_1 c_2 V_{R0}}{b\omega_0}. \quad (\text{c1})$$

Then, since the phase of the input signal is $-\frac{\pi}{2} + \frac{\pi}{2} = 0$ at the resonance, $\phi_i = 0$ and

the lock-in amplifier signal is

$$\frac{1}{2} V_{i0} V_{R0} \cos 0 = \frac{c_1 c_2 V_{R0}^2}{2 b\omega_0}. \quad (\text{c2})$$

(d) [2 points]

The original resonance frequency $\omega_0 = \sqrt{\frac{k}{m}}$ is shifted to

$$\sqrt{\frac{k}{m + \Delta m}} = \sqrt{\frac{k}{m} \left(1 + \frac{\Delta m}{m}\right)^{-1}} \cong \sqrt{\frac{k}{m} \left(1 - \frac{1}{2} \frac{\Delta m}{m}\right)} = \omega_0 \left(1 - \frac{1}{2} \frac{\Delta m}{m}\right). \quad (\text{d1})$$

Thus

$$\Delta\omega_0 = -\frac{1}{2} \omega_0 \frac{\Delta m}{m}. \quad (\text{d2})$$

Near the resonance, by substituting $\phi \rightarrow \frac{\pi}{2} + \Delta\phi$ and $\omega_0 \rightarrow \omega_0 + \Delta\omega_0$ in Eq. (a3), the

change of the phase due to the small change of ω_0 (not the change of ω) is

$$\tan\left(\frac{\pi}{2} + \Delta\phi\right) = -\frac{1}{\tan \Delta\phi} = \frac{b}{2m\Delta\omega_0}. \quad (\text{d3})$$

Therefore,

$$\Delta\phi \approx \tan \Delta\phi = -\frac{2m\Delta\omega_0}{b}. \quad (\text{d4})$$

From Eqs. (d2) and (d4),

$$\Delta m = \frac{b}{\omega_0} \Delta\phi = \frac{10^3 \cdot 10^{-12}}{10^6} \frac{\pi}{1800} = \frac{\pi}{1.8} 10^{-18} = 1.7 \times 10^{-18} \text{ kg}. \quad (\text{d5})$$

(e) [1.5 points]

In the presence of interaction, the equation of motion near the new equilibrium position h_0 becomes

$$m \frac{d^2 z}{dt^2} + b \frac{dz}{dt} + m\omega_0^2 z - c_3 z = F_0 \sin \omega t \quad (\text{e1})$$

where we used $f(h) \approx f(h_0) + c_3 z$ with $z = h - h_0$ being the displacement from the new equilibrium position h_0 . Note that the constant term $f(h_0)$ is cancelled at the new equilibrium position.

Thus the original resonance frequency $\omega_0 = \sqrt{\frac{k}{m}}$ will be shifted to

$$\omega'_0 = \sqrt{\frac{k - c_3}{m}} = \sqrt{\frac{m\omega_0^2 - c_3}{m}} = \omega_0 \sqrt{1 - \frac{c_3}{m\omega_0^2}}. \quad (\text{e3})$$

Hence the resonance frequency shift is given by

$$\Delta\omega_0 = \omega_0 \left[\sqrt{1 - \frac{c_3}{m\omega_0^2}} - 1 \right]. \quad (\text{e4})$$

(f) [2.5 points]

The maximum shift occurs when the cantilever is on top of the charge, where the interacting force is given by

$$f(h) = k_e \frac{qQ}{h^2}. \quad (\text{f1})$$

From this,

$$c_3 = \left. \frac{df}{dh} \right|_{h=d_0} = -2k_e \frac{qQ}{d_0^3}. \quad (\text{f2})$$

Since $\Delta\omega_0 \ll \omega_0$, we can approximate Eq. (e4) as

$$\Delta\omega_0 \approx -\frac{c_3}{2m\omega_0}. \quad (\text{f3})$$

From Eqs. (f2) and (f3), we have

$$\Delta\omega_0 = -\frac{1}{2m\omega_0} \left(-2k_e \frac{qQ}{d_0^3} \right) = k_e \frac{qQ}{m\omega_0 d_0^3}. \quad (\text{f4})$$

Here $q = e = -1.6 \times 10^{-19}$ Coulomb and $Q = 6e = -9.6 \times 10^{-19}$ Coulomb. Using the values provided,

$$d_0 = \left(k_e \frac{qQ}{m\omega_0\Delta\omega_0} \right)^{1/3} = 4.1 \times 10^{-8} \text{ m} = 41 \text{ nm.} \quad (\text{f5})$$

Thus the trapped electron is 41 nm from the cantilever.

3. Mark Distribution

No.	Total Pt.	Partial Pt.	Contents
(a)	1.5	0.7	Equations for A and ϕ (substitution and manipulation)
		0.4	Correct answers for A and ϕ
		0.4	A and ϕ at ω_0
(b)	1.0	0.4	Equation for the multiplied signal
		0.3	Condition for the non-vanishing dc output
		0.3	Correct answer for the dc output
(c)	1.5	0.6	Relation between V_i and V_R
		0.4	Condition for the maximum dc output
		0.5	Correct answer for the magnitude of dc output
(d)	2.0	0.5	Relation between Δm and $\Delta\omega_0$
		1.0	Relations between $\Delta\omega_0$ (or Δm) and $\Delta\phi$
		0.5	Correct answer (Partial credit of 0.2 for the wrong sign.)
(e)	1.5	1.0	Modification of the equation with $f(h)$ and use of a proper approximation for the equation
		0.5	Correct answer
(f)	2.5	0.5	Use of a correct formula of Coulomb force
		0.3	Evaluation of c_3
		0.6	Use of the result in (e) for either $\Delta\omega_0$ or $\omega_0'^2 - \omega_0^2$
		0.6	Expression for d_0
		0.5	Correct answer
Total	10		

Solutions

PART-A Product of the mass and the position of the ball ($m \times l$) **(4.0 points)**

1. Suggest and justify, by using equations, a method allowing to obtain $m \times l$. (2.0 points)

$$m \times l = (M + m) \times l_{\text{cm}}$$

(Explanation) The lever rule is applied to the Mechanical “Black Box”, shown in Fig. A-1, once the position of the center of mass of the whole system is found.

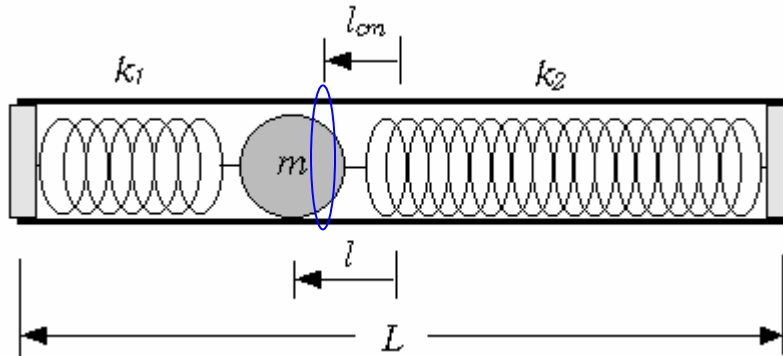

Fig. A-1 Experimental setup

2. Experimentally determine the value of $m \times l$. (2.0 points)

$$m \times l = 2.96 \times 10^{-3} \text{ kg} \cdot \text{m}$$

(Explanation) The measured quantities are

$$M + m = (1.411 \pm 0.0005) \times 10^{-1} \text{ kg}$$

and

$$l_{\text{cm}} = (2.1 \pm 0.06) \times 10^{-2} \text{ m} \quad \text{or} \quad 21 \pm 0.6 \text{ mm.}$$

Therefore

$$\begin{aligned} m \times l &= (M + m) \times l_{\text{cm}} \\ &= (1.411 \pm 0.0005) \times 10^{-1} \text{ kg} \times (2.1 \pm 0.06) \times 10^{-2} \text{ m} \\ &= (2.96 \pm 0.08) \times 10^{-3} \text{ kg} \cdot \text{m} \end{aligned}$$

PART-B The mass m of the ball (10.0 points)

1. Measure v for various values of h . Plot the data on a graph paper in a form that is suitable to find the value of m . Identify the slow rotation region and the fast rotation region on the graph. (4.0 points)
2. Show from your measurements that $h = C v^2$ in the slow rotation region, and $h = A v^2 + B$ in the fast rotation region. (1.0 points)

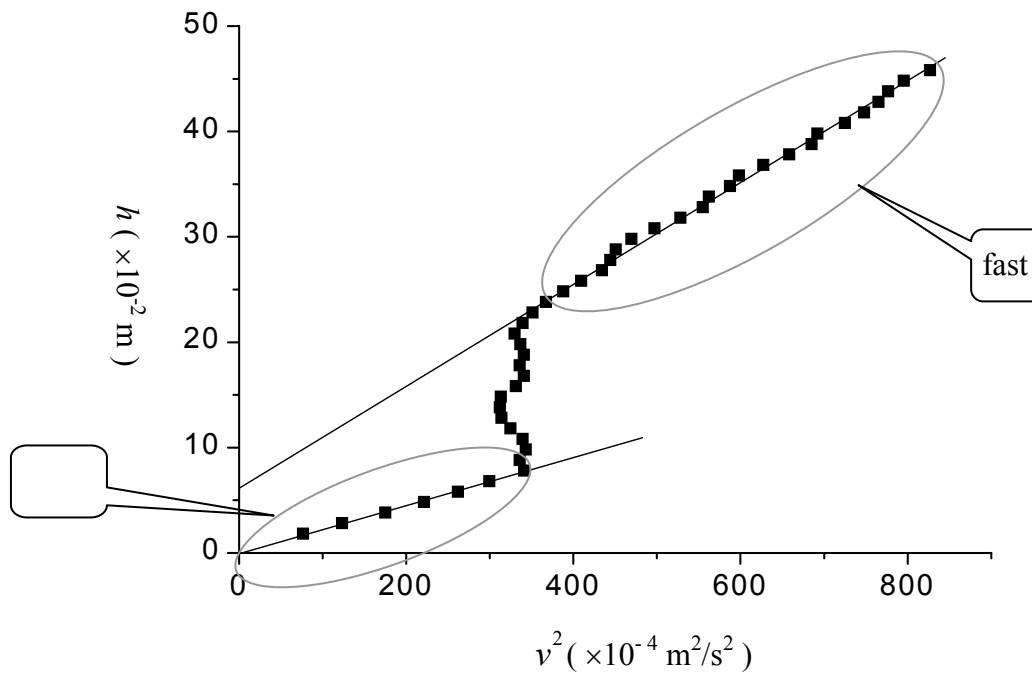

Fig. B-1 Experimental data

(Explanation) The measured data are

	h_1 ($\times 10^{-2}$ m) ^{a)}	Δt (ms)	h ($\times 10^{-2}$ m) ^{b)}	v ($\times 10^{-2}$ m/s) ^{c)}	v^2 ($\times 10^{-4}$ m ² /s ²)
1	25.5 ± 0.1	269.4 ± 0.05	1.8 ± 0.1	8.75 ± 0.02	76.6 ± 0.2
2	26.5 ± 0.1	235.7 ± 0.05	2.8 ± 0.1	11.12 ± 0.02	123.7 ± 0.3
3	27.5 ± 0.1	197.9 ± 0.05	3.8 ± 0.1	13.24 ± 0.03	175.3 ± 0.6
4	28.5 ± 0.1	176.0 ± 0.05	4.8 ± 0.1	14.89 ± 0.03	221.7 ± 0.6
5	29.5 ± 0.1	161.8 ± 0.05	5.8 ± 0.1	16.19 ± 0.03	262.1 ± 0.7
6	30.5 ± 0.1	151.4 ± 0.05	6.8 ± 0.1	17.31 ± 0.03	299.6 ± 0.7
7	31.5 ± 0.1	141.8 ± 0.05	7.8 ± 0.1	18.48 ± 0.04	342 ± 1
8	32.5 ± 0.1	142.9 ± 0.05	8.8 ± 0.1	18.33 ± 0.04	336 ± 1

9	33.5±0.1	141.4±0.05	9.8±0.1	18.53±0.04	343±1
10	34.5±0.1	142.2±0.05	10.8±0.1	18.42±0.04	339±1
11	35.5±0.1	145.4±0.05	11.8±0.1	18.02±0.04	325±1
12	36.5±0.1	147.8±0.05	12.8±0.1	17.73±0.04	314±1
13	37.5±0.1	148.3±0.05	13.8±0.1	17.67±0.04	312±1
14	38.5±0.1	148.0±0.05	14.8±0.1	17.70±0.04	313±1
15	39.5±0.1	143.9±0.05	15.8±0.1	18.21±0.04	332±1
16	40.5±0.1	141.9±0.05	16.8±0.1	18.46±0.04	341±1
17	41.5±0.1	142.9±0.05	17.8±0.1	18.33±0.04	336±1
18	42.5±0.1	141.9±0.05	18.8±0.1	18.46±0.04	341±1
19	43.5±0.1	142.8±0.05	19.8±0.1	18.35±0.04	337±1
20	44.5±0.1	144.3±0.05	20.8±0.1	18.16±0.04	330±1
21	45.5±0.1	142.2±0.05	21.8±0.1	18.42±0.04	339±1
22	46.5±0.1	139.8±0.05	22.8±0.1	18.74±0.04	351±1
23	47.5±0.1	136.7±0.05	23.8±0.1	19.17±0.04	368±1
24	48.5±0.1	133.0±0.05	24.8±0.1	19.70±0.04	388±1
25	49.5±0.1	129.5±0.05	25.8±0.1	20.23±0.04	409±1
26	50.5±0.1	125.7±0.05	26.8±0.1	20.84±0.04	434±1
27	51.5±0.1	124.3±0.05	27.8±0.1	21.08±0.04	444±1
28	52.5±0.1	123.4±0.05	28.8±0.1	21.23±0.04	451±1
29	53.5±0.1	120.9±0.05	29.8±0.1	21.67±0.04	470±1
30	54.5±0.1	117.5±0.05	30.8±0.1	22.30±0.04	497±1
31	55.5±0.1	114.0±0.05	31.8±0.1	22.98±0.04	528±1
32	56.5±0.1	111.2±0.05	32.8±0.1	23.56±0.05	555±2
33	57.5±0.1	110.5±0.05	33.8±0.1	23.71±0.05	562±2
34	58.5±0.1	108.1±0.05	34.8±0.1	24.24±0.05	588±2
35	59.5±0.1	107.1±0.05	35.8±0.1	24.46±0.05	598±2
36	60.5±0.1	104.6±0.05	36.8±0.1	25.05±0.05	628±2
37	61.5±0.1	102.1±0.05	37.8±0.1	25.66±0.05	658±2
38	62.5±0.1	100.1±0.05	38.8±0.1	26.17±0.05	685±2
39	63.5±0.1	99.6±0.05	39.8±0.1	26.31±0.05	692±2
40	64.5±0.1	97.3±0.05	40.8±0.1	26.93±0.05	725±2
41	65.5±0.1	95.8±0.05	41.8±0.1	27.35±0.05	748±2
42	66.5±0.1	94.7±0.05	42.8±0.1	27.67±0.05	766±2
43	67.5±0.1	94.0±0.05	43.8±0.1	27.87±0.06	777±2
44	68.5±0.1	92.9±0.05	44.8±0.1	28.20±0.06	795±2
45	69.5±0.1	91.1±0.05	45.8±0.1	28.76±0.06	827±2

- where
- a) h_1 is the reading of the top position of the weight before it starts to fall,
 - b) h is the distance of fall of the weight which is obtained by $h = h_1 - h_2 + d/2$,
 h_2 ($= (25 \pm 0.05) \times 10^{-2}$ m) is the top position of the weight at the start of blocking of the photogate,
 d ($= (2.62 \pm 0.005) \times 10^{-2}$ m) is the length of the weight, and
 - c) v is obtained from $v = d/\Delta t$.

3. Relate the coefficient C to the parameters of the MBB. (1.0 points)

$$h = C v^2, \text{ where } C = \{m_o + I/R^2 + m(l^2 + 2/5 r^2)/R^2\}/2m_o g$$

(Explanation) The ball is at static equilibrium ($x = l$). When the speed of the weight is v , the increase in kinetic energy of the whole system is given by

$$\begin{aligned} \Delta K &= 1/2 m_o v^2 + 1/2 I \omega^2 + 1/2 m(l^2 + 2/5 r^2) \omega^2 \\ &= 1/2 \{m_o + I/R^2 + m(l^2 + 2/5 r^2)/R^2\} v^2, \end{aligned}$$

where ω ($= v/R$) is the angular velocity of the Mechanical “Black Box” and I is the *effective* moment of inertia of the whole system except the ball. Since the decrease in gravitational potential energy of the weight is

$$\Delta U = - m_o g h,$$

the energy conservation ($\Delta K + \Delta U = 0$) gives

$$\begin{aligned} h &= 1/2 \{m_o + I/R^2 + m(l^2 + 2/5 r^2)/R^2\} v^2 / m_o g \\ &= C v^2, \text{ where } C = \{m_o + I/R^2 + m(l^2 + 2/5 r^2)/R^2\} / 2m_o g \end{aligned}$$

4. Relate the coefficients A and B to the parameters of the MBB. (1.0 points)

$$\begin{aligned} h &= A v^2 + B, \text{ where } A = [m_o + I/R^2 + m\{(L/2 - \delta - r)^2 + 2/5 r^2\}/R^2] / 2m_o g \\ &\text{and } B = [-k_1(L/2 - l - \delta - r)^2 \\ &\quad + k_2\{(L - 2\delta - 2r)^2 - (L/2 + l - \delta - r)^2\}] / 2m_o g \end{aligned}$$

(Explanation) The ball stays at the end cap of the tube ($x = L/2 - \delta - r$). When the speed of the weight is v , the increase in kinetic energy of the whole system is given by

$$K = 1/2 [m_0 + I/R^2 + m\{(L/2 - \delta - r)^2 + 2/5 r^2\}/R^2]v^2.$$

Since the increase in elastic potential energy of the springs is

$$\Delta U_e = 1/2 [-k_1(L/2 - l - \delta - r)^2 + k_2\{(L - 2\delta - 2r)^2 - (L/2 + l - \delta - r)^2\}],$$

the energy conservation ($K + \Delta U + \Delta U_e = 0$) gives

$$h = 1/2 [m_0 + I/R^2 + m\{(L/2 - \delta - r)^2 + 2/5 r^2\}/R^2]v^2/m_0g + \Delta U_e/m_0g = Av^2 + B,$$

where

$$A = [m_0 + I/R^2 + m\{(L/2 - \delta - r)^2 + 2/5 r^2\}/R^2]/2m_0g$$

and

$$B = [-k_1(L/2 - l - \delta - r)^2 + k_2\{(L - 2\delta - 2r)^2 - (L/2 + l - \delta - r)^2\}]/2m_0g.$$

5. Determine the value of m from your measurements and the results obtained in **PART-A**. (3.0 points)

$$m = 6.2 \times 10^{-2} \text{ kg}$$

(Explanation) From the results obtained in **PART-B** 3 and 4 we get

$$A - C = \frac{m}{2gm_0R^2} \left\{ \left(\frac{L}{2} - \delta - r \right)^2 - l^2 \right\}.$$

The measured values are $L = (40.0 \pm 0.05) \times 10^{-2} \text{ m}$
 $m_0 = (100.4 \pm 0.05) \times 10^{-3} \text{ kg}$
 $2R = (3.91 \pm 0.005) \times 10^{-2} \text{ m}$

Therefore,

$$(L/2 - \delta - r)^2 = \{(20.0 \pm 0.03) - 0.5 - 1.1\}^2 \times 10^{-4} \text{ m}^2 = (338.6 \pm 0.8) \times 10^{-4} \text{ m}^2$$

and

$$2gm_0R^2 = 2 \times 980 \times (100.4 \pm 0.05) \times (1.955 \pm 0.003)^2 \times 10^{-6} \text{ kg} \cdot \text{m}^3/\text{s}^2 = (752 \pm 2) \times 10^{-6} \text{ kg} \cdot \text{m}^3/\text{s}^2.$$

The slopes of the two straight lines in the graph (Fig. B-1) of **PART-B** 1 are

$$A = 5.0 \pm 0.1 \text{ s}^2/\text{m} \quad \text{and} \quad C = 2.4 \pm 0.1 \text{ s}^2/\text{m},$$

respectively, and

$$A - C = 2.6 \pm 0.1 \text{ s}^2/\text{m}.$$

Since we already obtained $m \times l = (M + m) \times l_{\text{cm}} = 2.96 \times 10^{-3} \text{ kg} \cdot \text{m}$ from **PART-A**, the equation

$$(338.6 \pm 0.8)m^2 - (752 \pm 2) \times 10^3 \times (0.026 \pm 0.001)m - (296 \pm 8)^2 = 0$$

or

$$(338.6 \pm 0.8)m^2 - (19600 \pm 800)m - (88000 \pm 3000) = 0$$

is resulted, where m is expressed in the unit of g.

The roots of this equation are

$$m = \frac{(9800 \pm 400) \pm \sqrt{(9800 \pm 400)^2 + (338.6 \pm 0.8) \times (88000 \pm 3000)}}{(338.6 \pm 0.8)}.$$

The physically meaningful positive root is

$$m = \frac{(9800 \pm 400) + \sqrt{(126000000 \pm 6000000)}}{(338.6 \pm 0.8)} = (62 \pm 2) \text{ g} = (6.2 \pm 0.2) \times 10^{-2} \text{ kg}.$$

PART-C The spring constants k_1 and k_2 (6.0 points)

1. Measure the periods T_1 and T_2 of small oscillation shown in Figs. 3 (1) and (2) and write down their values, respectively. (1.0 points)

$$T_1 = 1.1090 \text{ s} \quad \text{and} \quad T_2 = 1.0193 \text{ s}$$

(Explanation)

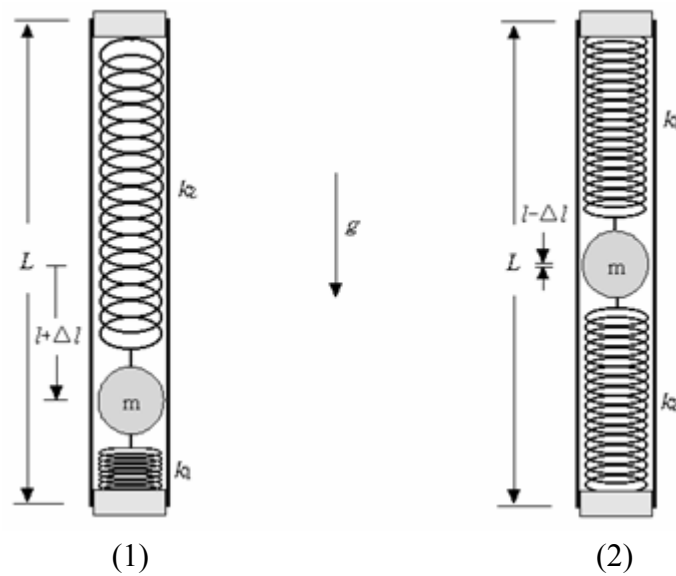

Fig. C-1 Small oscillation experimental set up

The measured periods are

	T_1 (s)		T_2 (s)
1	1.1085 ± 0.00005	1	1.0194 ± 0.00005
2	1.1092 ± 0.00005	2	1.0194 ± 0.00005
3	1.1089 ± 0.00005	3	1.0193 ± 0.00005
4	1.1085 ± 0.00005	4	1.0191 ± 0.00005
5	1.1094 ± 0.00005	5	1.0192 ± 0.00005
6	1.1090 ± 0.00005	6	1.0194 ± 0.00005
7	1.1088 ± 0.00005	7	1.0194 ± 0.00005
8	1.1090 ± 0.00005	8	1.0191 ± 0.00005
9	1.1092 ± 0.00005	9	1.0192 ± 0.00005
10	1.1094 ± 0.00005	10	1.0193 ± 0.00005

By averaging the 10 measurements for each configuration, respectively, we get

$$T_1 = 1.1090 \pm 0.0003 \text{ s} \quad \text{and} \quad T_2 = 1.0193 \pm 0.0001 \text{ s}.$$

2. Explain, by using equations, why the angular frequencies ω_1 and ω_2 of small oscillation of the configurations are different. (1.0 points)

$$\omega_1 = \sqrt{\frac{Mg \frac{L}{2} + mg \left(\frac{L}{2} + l + \Delta l \right)}{I_o + m \left\{ \left(\frac{L}{2} + l + \Delta l \right)^2 + \frac{2}{5} r^2 \right\}}}$$

$$\omega_2 = \sqrt{\frac{Mg \frac{L}{2} + mg \left(\frac{L}{2} - l + \Delta l \right)}{I_o + m \left\{ \left(\frac{L}{2} - l + \Delta l \right)^2 + \frac{2}{5} r^2 \right\}}}$$

(Explanation) The moment of inertia of the Mechanical “Black Box” with respect to the pivot at the top of the tube is

$$I_1 = I_o + m \left\{ \left(\frac{L}{2} + l + \Delta l \right)^2 + \frac{2}{5} r^2 \right\} \quad \text{or} \quad I_2 = I_o + m \left\{ \left(\frac{L}{2} - l + \Delta l \right)^2 + \frac{2}{5} r^2 \right\}$$

depending on the orientation of the MBB as shown in Figs. C-1(1) and (2), respectively.

When the MBB is slightly tilted by an angle θ from vertical, the torque applied by the gravity is

$$\tau_1 = Mg \left(\frac{L}{2} \right) \sin \theta + mg \left(\frac{L}{2} + l + \Delta l \right) \sin \theta \approx \left\{ Mg \left(\frac{L}{2} \right) + mg \left(\frac{L}{2} + l + \Delta l \right) \right\} \theta$$

or

$$\tau_2 = Mg \left(\frac{L}{2} \right) \sin \theta + mg \left(\frac{L}{2} - l + \Delta l \right) \sin \theta \approx \left\{ Mg \left(\frac{L}{2} \right) + mg \left(\frac{L}{2} - l + \Delta l \right) \right\} \theta$$

depending on the orientation.

Therefore, the angular frequencies of oscillation become

$$\omega_1 = \sqrt{\frac{\tau_1 / \theta}{I_1}} = \sqrt{\frac{Mg \frac{L}{2} + mg \left(\frac{L}{2} + l + \Delta l \right)}{I_o + m \left\{ \left(\frac{L}{2} + l + \Delta l \right)^2 + \frac{2}{5} r^2 \right\}}}$$

and

$$\omega_2 = \sqrt{\frac{\tau_2 / \theta}{I_2}} = \sqrt{\frac{Mg \frac{L}{2} + mg \left(\frac{L}{2} - l + \Delta l \right)}{I_o + m \left\{ \left(\frac{L}{2} - l + \Delta l \right)^2 + \frac{2}{5} r^2 \right\}}}$$

3. Evaluate Δl by eliminating I_0 from the previous results. (1.0 points)

$$\Delta l = (7.2 \pm 0.9) \text{ cm} = (7.2 \pm 0.9) \times 10^{-2} \text{ m}$$

(Explanation) By rewriting the two expressions for the angular frequencies ω_1 and ω_2 as

$$Mg \frac{L}{2} + mg \left(\frac{L}{2} + l + \Delta l \right) = I_0 \omega_1^2 + m \omega_1^2 \left\{ \left(\frac{L}{2} + l + \Delta l \right)^2 + \frac{2}{5} r^2 \right\}$$

and

$$Mg \frac{L}{2} + mg \left(\frac{L}{2} - l + \Delta l \right) = I_0 \omega_2^2 + m \omega_2^2 \left\{ \left(\frac{L}{2} - l + \Delta l \right)^2 + \frac{2}{5} r^2 \right\}$$

one can eliminate the unknown moment of inertia I_0 of the MBB without the ball.

By eliminating the I_0 one gets the equation for Δl

$$(\omega_2^2 - \omega_1^2) \left\{ \frac{(M+m)gL}{2} + mg\Delta l \right\} + (\omega_1^2 + \omega_2^2) mgl = \omega_1^2 \omega_2^2 m(L + 2\Delta l)(2l).$$

From the measured or given values we get,

$$\begin{aligned} (\omega_2^2 - \omega_1^2) &= \left\{ \left(\frac{2\pi}{T_2} \right)^2 - \left(\frac{2\pi}{T_1} \right)^2 \right\} = \left(\frac{6.2832}{1.0193 \pm 0.0001} \right)^2 - \left(\frac{6.2832}{1.1090 \pm 0.0003} \right)^2 \\ &= 5.90 \pm 0.01 \text{ s}^{-2} \end{aligned}$$

$$\frac{(M+m)gL}{2} = \frac{(141.1 \pm 0.05) \times 980 \times (40.0 \pm 0.05)}{2} = (27.66 \pm 0.04) \times 10^{-2} \text{ kg} \cdot \text{m}^2 / \text{s}^2$$

$$\begin{aligned} (\omega_1^2 + \omega_2^2) mgl &= \left\{ \left(\frac{2\pi}{T_1} \right)^2 + \left(\frac{2\pi}{T_2} \right)^2 \right\} (M+m) l_{cm} g \\ &= \left\{ \left(\frac{6.2832}{1.1090 \pm 0.0003} \right)^2 + \left(\frac{6.2832}{1.0193 \pm 0.0001} \right)^2 \right\} \times (296 \pm 8) \times 980 \end{aligned}$$

$$= (203 \pm 5) \times 10^{-2} \text{ kg} \cdot \text{m}^2 / \text{s}^4$$

$$\begin{aligned} \omega_1^2 \omega_2^2 m l &= \left(\frac{2\pi}{T_1} \right)^2 \left(\frac{2\pi}{T_2} \right)^2 (M + m) l_{cm} \\ &= \left(\frac{6.2832}{1.1090 \pm 0.0003} \right)^2 \left(\frac{6.2832}{1.0193 \pm 0.0001} \right)^2 \times (296 \pm 8) \\ &= (3.6 \pm 0.1) \text{ kg} \cdot \text{m} / \text{s}^4. \end{aligned}$$

Therefore, the equation we obtained in **PART-C 3** becomes

$$\begin{aligned} (5.90 \pm 0.01) \{ (27.66 \pm 0.04) \times 10^5 + (62 \pm 2) \times 980 \times \Delta l \} + (203 \pm 5) \times 10^5 \\ = (7.2 \pm 0.2) \times 10^5 \times \{ (40.0 \pm 0.05) + 2\Delta l \}, \end{aligned}$$

where Δl is expressed in the unit of cm. By solving the equation we get

$$\Delta l = (7.2 \pm 0.9) \text{ cm} = (7.2 \pm 0.9) \times 10^{-2} \text{ m}$$

4. Write down the value of the effective total spring constant k of the two-spring system. (2.0 points)

$$k = 9 \text{ N/m}$$

(Explanation) The effective total spring constant is

$$k \equiv \frac{mg}{\Delta l} = \frac{(62 \pm 2) \times 980}{7.2 \pm 0.9} = 9000 \pm 1000 \text{ dyne/cm} \quad \text{or} \quad 9 \pm 1 \text{ N/m}.$$

5. Obtain the respective values of k_1 and k_2 . Write down their values. (1.0 point)

$$k_1 = 5.7 \text{ N/m}$$

$$k_2 = 3 \text{ N/m}$$

(Explanation) When the MBB is in equilibrium on a horizontal plane the force balance condition for the ball is that

$$\frac{L/2 - l - \delta - r}{L/2 + l - \delta - r} = \frac{N_1}{N_2} = \frac{k_2}{k_1}.$$

Since $k = k_1 + k_2$, we get

$$k_1 = \frac{k}{\frac{L/2 - l - \delta - r}{L/2 + l - \delta - r} + 1} = \frac{L/2 + l - \delta - r}{L - 2\delta - 2r} k$$

and

$$k_2 = k - k_1 = \frac{L/2 - l - \delta - r}{L - 2\delta - 2r} k.$$

From the measured or given values

$$\frac{L/2 + l - \delta - r}{L - 2\delta - 2r} = \frac{(20.0 \pm 0.03) + \left(\frac{296 \pm 8}{62 \pm 2}\right) - 0.5 - 1.1}{(40.0 \pm 0.05) - 1.0 - 2.2} = 0.63 \pm 0.005.$$

Therefore,

$$k_1 = (0.63 \pm 0.005) \times (9000 \pm 1000) = 5700 \pm 600 \text{ dyne/cm} \quad \text{or} \quad 5.7 \pm 0.6 \text{ N/m},$$

and

$$k_2 = (9000 \pm 1000) - (5700 \pm 600) = 3000 \pm 1000 \text{ dyne/cm} \quad \text{or} \quad 3 \pm 1 \text{ N/m}.$$

Th 1 AN ILL FATED SATELLITE

The most frequent orbital manoeuvres performed by spacecraft consist of velocity variations along the direction of flight, namely accelerations to reach higher orbits or brakings done to initiate re-entering in the atmosphere. In this problem we will study the orbital variations when the engine thrust is applied in a radial direction.

To obtain numerical values use: Earth radius $R_T = 6.37 \cdot 10^6$ m, Earth surface gravity $g = 9.81$ m/s², and take the length of the sidereal day to be $T_0 = 24.0$ h.

We consider a geosynchronous¹ communications satellite of mass m placed in an equatorial circular orbit of radius r_0 . These satellites have an “apogee engine” which provides the tangential thrusts needed to reach the final orbit.

Marks are indicated at the beginning of each subquestion, in parenthesis.

Question 1

- 1.1 (0.3) Compute the numerical value of r_0 .
- 1.2 (0.3+0.1) Give the analytical expression of the velocity v_0 of the satellite as a function of g , R_T , and r_0 , and calculate its numerical value.
- 1.3 (0.4+0.4) Obtain the expressions of its angular momentum L_0 and mechanical energy E_0 , as functions of v_0 , m , g and R_T .

Once this geosynchronous circular orbit has been reached (see Figure F-1), the satellite has been stabilised in the desired location, and is being readied to do its work, an error by the ground controllers causes the apogee engine to be fired again. The thrust happens to be directed towards the Earth and, despite the quick reaction of the ground crew to shut the engine off, an unwanted velocity variation Δv is imparted on the satellite. We characterize this boost by the parameter $\beta = \Delta v / v_0$. The duration of the engine burn is always negligible with respect to any other orbital times, so that it can be considered as instantaneous.

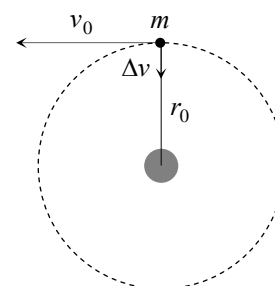

F-1

Question 2

Suppose $\beta < 1$.

- 2.1 (0.4+0.5) Determine the parameters of the new orbit², *semi-latus-rectum* l and *eccentricity* ε , in terms of r_0 and β .
- 2.2 (1.0) Calculate the angle α between the major axis of the new orbit and the position vector at the accidental misfire.
- 2.3 (1.0+0.2) Give the analytical expressions of the perigee r_{min} and apogee r_{max} distances to the Earth centre, as functions of r_0 and β , and calculate their numerical values for $\beta = 1/4$.
- 2.4 (0.5+0.2) Determine the period of the new orbit, T , as a function of T_0 and β , and calculate its numerical value for $\beta = 1/4$.

¹ Its revolution period is T_0 .

² See the “hint”.

Question 3

- 3.1 (0.5) Calculate the minimum boost parameter, β_{esc} , needed for the satellite to escape Earth gravity.
- 3.2 (1.0) Determine in this case the closest approach of the satellite to the Earth centre in the new trajectory, r'_{min} , as a function of r_0 .

Question 4

Suppose $\beta > \beta_{esc}$.

- 4.1 (1.0) Determine the residual velocity at the infinity, v_∞ , as a function of v_0 and β .
- 4.2 (1.0) Obtain the “impact parameter” b of the asymptotic escape direction in terms of r_0 and β . (See Figure F-2).
- 4.3 (1.0+0.2) Determine the angle ϕ of the asymptotic escape direction in terms of β . Calculate its numerical value for $\beta = \frac{3}{2} \beta_{esc}$.

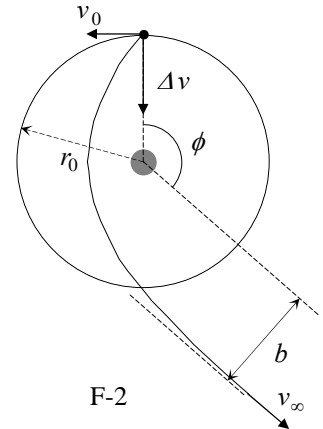

HINT

Under the action of central forces obeying the inverse-square law, bodies follow trajectories described by ellipses, parabolas or hyperbolas. In the approximation $m \ll M$ the gravitating mass M is at one of the foci. Taking the origin at this focus, the general polar equation of these curves can be written as (see Figure F-3)

$$r(\theta) = \frac{l}{1 - \varepsilon \cos \theta}$$

where l is a positive constant named the *semi-latus-rectum* and ε is the *eccentricity* of the curve. In terms of constants of motion:

$$l = \frac{L^2}{GMm^2} \quad \text{and} \quad \varepsilon = \left(1 + \frac{2EL^2}{G^2M^2m^3} \right)^{1/2}$$

where G is the Newton constant, L is the modulus of the angular momentum of the orbiting mass, with respect to the origin, and E is its mechanical energy, with zero potential energy at infinity.

We may have the following cases:

- i) If $0 \leq \varepsilon < 1$, the curve is an ellipse (circumference for $\varepsilon = 0$).
- ii) If $\varepsilon = 1$, the curve is a parabola.
- iii) If $\varepsilon > 1$, the curve is a hyperbola.

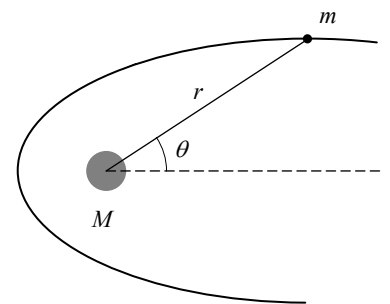

F-3

COUNTRY CODE	STUDENT CODE	PAGE NUMBER	TOTAL No OF PAGES

Th 1 ANSWER SHEET

Question	Basic formulas and ideas used	Analytical results	Numerical results	Marking guideline
1.1			$r_0 =$	0.3
1.2		$v_0 =$	$v_0 =$	0.4
1.3		$L_0 =$		0.4
		$E_0 =$		0.4
2.1		$l =$		0.4
		$\varepsilon =$		0.5
2.2			$\alpha =$	1.0
2.3		$r_{max} =$	$r_{max} =$	1.2
		$r_{min} =$	$r_{min} =$	
2.4		$T =$	$T =$	0.7
3.1			$\beta_{esc} =$	0.5
3.2		$r'_{min} =$		1.0
4.1		$v_{\infty} =$		1.0
4.2		$b =$		1.0
4.3		$\phi =$	$\phi =$	1.2

Th 2 ABSOLUTE MEASUREMENTS OF ELECTRICAL QUANTITIES

The technological and scientific transformations underwent during the XIX century produced a compelling need of universally accepted standards for the electrical quantities. It was thought the new absolute units should only rely on the standards of length, mass and time established after the French Revolution. An intensive experimental work to settle the values of these units was developed from 1861 until 1912. We propose here three case studies.

Marks are indicated at the beginning of each subquestion, in parenthesis.

Determination of the ohm (Kelvin)

A closed circular coil of N turns, radius a and total resistance R is rotated with uniform angular velocity ω about a vertical diameter in a horizontal magnetic field $\vec{B}_0 = B_0 \vec{i}$.

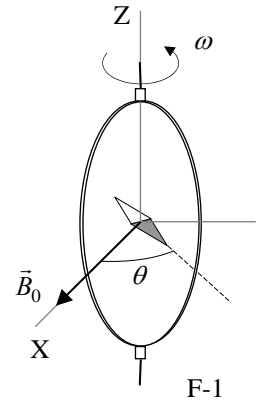

1. (0.5+1.0) Compute the electromotive force \mathcal{E} induced in the coil, and also the mean power¹ $\langle P \rangle$ required for maintaining the coil in motion. Neglect the coil self inductance.

A small magnetic needle is placed at the center of the coil, as shown in Figure F-1. It is free to turn slowly around the Z axis in a horizontal plane, but it cannot follow the rapid rotation of the coil.

2. (2.0) Once the stationary regime is reached, the needle will set at a direction making a small angle θ with \vec{B}_0 . Compute the resistance R of the coil in terms of this angle and the other parameters of the system.

Lord Kelvin used this method in the 1860s to set the absolute standard for the ohm. To avoid the rotating coil, Lorenz devised an alternative method used by Lord Rayleigh and Ms. Sidgwick, that we analyze in the next paragraphs.

Determination of the ohm (Rayleigh, Sidgwick).

The experimental setup is shown in Figure F-2. It consists of two identical metal disks D and D' of radius b mounted on the conducting shaft SS'. A motor rotates the set at an angular velocity ω , which can be adjusted for measuring R . Two identical coils C and C' (of radius a and with N turns each) surround the disks. They are connected in such a form that the current I flows through them in opposite directions. The whole apparatus serves to measure the resistance R .

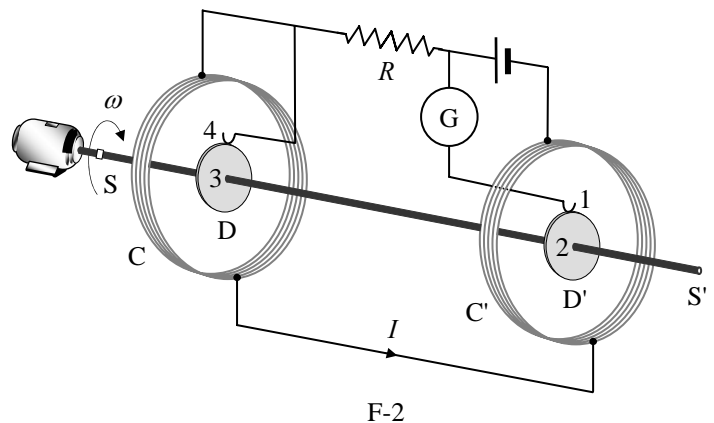

¹ The mean value $\langle X \rangle$ of a quantity $X(t)$ in a periodic system of period T is $\langle X \rangle = \frac{1}{T} \int_0^T X(t) dt$

You may need one or more of these integrals:

$$\int_0^{2\pi} \sin x \, dx = \int_0^{2\pi} \cos x \, dx = \int_0^{2\pi} \sin x \cos x \, dx = 0, \quad \int_0^{2\pi} \sin^2 x \, dx = \int_0^{2\pi} \cos^2 x \, dx = \pi, \quad \text{and later} \quad \int x^n \, dx = \frac{1}{n+1} x^{n+1}$$

3. (2.0) Assume that the current I flowing through the coils C and C' creates a uniform magnetic field B around D and D' , equal to the one at the centre of the coil. Compute¹ the electromotive force \mathcal{E} induced between the rims 1 and 4, assuming that the distance between the coils is much larger than the radius of the coils and that $a \gg b$.

The disks are connected to the circuit by brush contacts at their rims 1 and 4. The galvanometer G detects the flow of current through the circuit 1-2-3-4.

4. (0.5) The resistance R is measured when G reads zero. Give R in terms of the physical parameters of the system.

Determination of the ampere

Passing a current through two conductors and measuring the force between them provides an absolute determination of the current itself. The “Current Balance” designed by Lord Kelvin in 1882 exploits this method. It consists of six identical single turn coils $C_1 \dots C_6$ of radius a , connected in series. As shown in Figure F-3, the fixed coils C_1, C_3, C_4 , and C_6 are on two horizontal planes separated by a small distance $2h$. The coils C_2 and C_5 are carried on balance arms of length d , and they are, in equilibrium, equidistant from both planes.

The current I flows through the various coils in such a direction that the magnetic force on C_2 is upwards while that on C_5 is downwards. A mass m at a distance x from the fulcrum O is required to restore the balance to the equilibrium position described above when the current flows through the circuit.

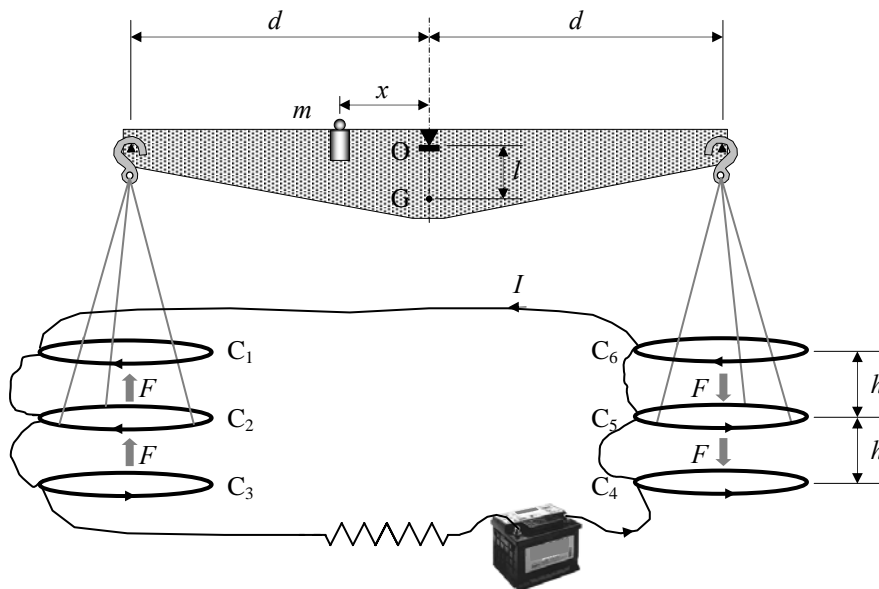

F-3

5. (1.0) Compute the force F on C_2 due to the magnetic interaction with C_1 . For simplicity assume that the force per unit length is the one corresponding to two long, straight wires carrying parallel currents.
6. (1.0) The current I is measured when the balance is in equilibrium. Give the value of I in terms of the physical parameters of the system. The dimensions of the apparatus are such that we can neglect the mutual effects of the coils on the left and on the right.

Let M be the mass of the balance (except for m and the hanging parts), G its centre of mass and l the distance \overline{OG} .

7. (2.0) The balance equilibrium is stable against deviations producing small changes δz in the height of C_2 and $-\delta z$ in C_5 . Compute² the maximum value δz_{\max} so that the balance still returns towards the equilibrium position when it is released.

² Consider that the coils centres remain approximately aligned.

Use the approximations $\frac{1}{1 \pm \beta} \approx 1 \mp \beta + \beta^2$ or $\frac{1}{1 \pm \beta^2} \approx 1 \mp \beta^2$ for $\beta \ll 1$, and $\sin \theta \approx \tan \theta$ for small θ .

COUNTRY CODE	STUDENT CODE	PAGE NUMBER	TOTAL No OF PAGES

Th 2 ANSWER SHEET

Question	Basic formulas used	Analytical results	Marking guideline
1		$\mathcal{E} =$ $\langle P \rangle =$	1.5
2		$R =$	2.0
3		$\mathcal{E} =$	2.0
4		$R =$	0,5
5		$F =$	1.0
6		$I =$	1.0
7		$\delta z_{\max} =$	2.0

Th 3 NEUTRONS IN A GRAVITATIONAL FIELD

In the familiar classical world, an elastic bouncing ball on the Earth's surface is an ideal example for perpetual motion. The ball is trapped: it can not go below the surface or above its turning point. It will remain bounded in this state, turning down and bouncing up once and again, forever. Only air drag or inelastic bounces could stop the process and will be ignored in the following.

A group of physicists from the Institute Laue - Langevin in Grenoble reported¹ in 2002 experimental evidence on the behaviour of neutrons in the gravitational field of the Earth. In the experiment, neutrons moving to the right were allowed to fall towards a horizontal crystal surface acting as a neutron mirror, where they bounced back elastically up to the initial height once and again.

The setup of the experiment is sketched in Figure F-1. It consists of the opening W, the neutron mirror M (at height $z = 0$), the neutron absorber A (at height $z = H$ and with length L) and the neutron detector D. The beam of neutrons flies with constant horizontal velocity component v_x from W to D through the cavity between A and M. All the neutrons that reach the surface of A are absorbed and disappear from the experiment. Those that reach the surface of M are reflected elastically. The detector D counts the transmission rate $N(H)$, that is, the total number of neutrons that reach D per unit time.

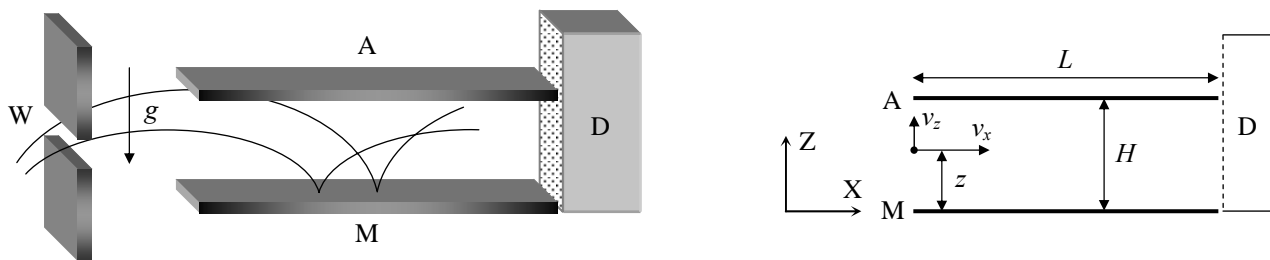

F-1

Marks are indicated at the beginning of each subquestion, in parenthesis.

The neutrons enter the cavity with a wide range of positive and negative vertical velocities, v_z . Once in the cavity, they fly between the mirror below and the absorber above.

1. (1.5) Compute classically the range of vertical velocities $v_z(z)$ of the neutrons that, entering at a height z , can arrive at the detector D. Assume that L is much larger than any other length in the problem.
2. (1.5) Calculate classically the minimum length L_c of the cavity to ensure that all neutrons outside the previous velocity range, regardless of the values of z , are absorbed by A. Use $v_x = 10 \text{ m s}^{-1}$ and $H = 50 \text{ }\mu\text{m}$.

The neutron transmission rate $N(H)$ is measured at D. We expect that it increases monotonically with H .

3. (2.5) Compute the classical rate $N_c(H)$ assuming that neutrons arrive at the cavity with vertical velocity v_z and at height z , being all the values of v_z and z equally probable. Give the answer in terms of ρ , the constant number of neutrons per unit time, per unit vertical velocity, per unit height, that enter the cavity with vertical velocity v_z and at height z .

¹ V. V. Nesvizhevsky *et al.* "Quantum states of neutrons in the Earth's gravitational field." *Nature*, **415** (2002) 297. *Phys Rev D* **67**, 102002 (2003).

The experimental results obtained by the Grenoble group disagree with the above classical predictions, showing instead that the value of $N(H)$ experiences sharp increases when H crosses some critical heights $H_1, H_2 \dots$ (Figure F-2 shows a sketch). In other words, the experiment showed that the vertical motion of neutrons bouncing on the mirror is quantized. In the language that Bohr and Sommerfeld used to obtain the energy levels of the hydrogen atom, this can be written as: “The action S of these neutrons along the vertical direction is an integer multiple of the Planck action constant h ”. Here S is given by

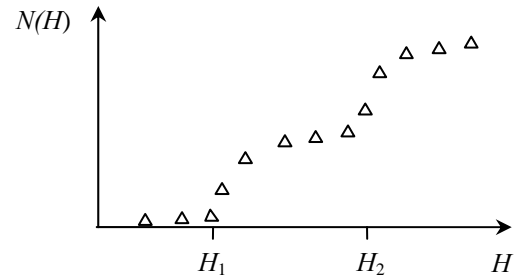

F-2

$$S = \int p_z(z) dz = nh, \quad n = 1, 2, 3 \dots \quad (\text{Bohr-Sommerfeld quantization rule})$$

where p_z is the vertical component of the classical momentum, and the integral covers a whole bouncing cycle. Only neutrons with these values of S are allowed in the cavity.

4. (2.5) Compute the turning heights H_n and energy levels E_n (associated to the vertical motion) using the Bohr-Sommerfeld quantization condition. Give the numerical result for H_1 in μm and for E_1 in eV.

The uniform initial distribution ρ of neutrons at the entrance changes, during the flight through a long cavity, into the step-like distribution detected at D (see Figure F-2). From now on, we consider for simplicity the case of a long cavity with $H < H_2$. Classically, all neutrons with energies in the range considered in question 1 were allowed through it, while quantum mechanically only neutrons in the energy level E_1 are permitted. According to the time-energy Heisenberg uncertainty principle, this reshuffling requires a minimum time of flight. The uncertainty of the vertical motion energy will be significant if the cavity length is small. This phenomenon will give rise to the widening of the energy levels.

5. (2.0) Estimate the minimum time of flight t_q and the minimum length L_q of the cavity needed to observe the first sharp increase in the number of neutrons at D. Use $v_x = 10 \text{ m s}^{-1}$.

Data:

Planck action constant	$h = 6.63 \cdot 10^{-34} \text{ J s}$
Speed of light in vacuum	$c = 3.00 \cdot 10^8 \text{ m s}^{-1}$
Elementary charge	$e = 1.60 \cdot 10^{-19} \text{ C}$
Neutron mass	$M = 1.67 \cdot 10^{-27} \text{ kg}$
Acceleration of gravity on Earth	$g = 9.81 \text{ m s}^{-2}$
If necessary, use the expression:	$\int (1-x)^{1/2} dx = -\frac{2(1-x)^{3/2}}{3}$

COUNTRY CODE	STUDENT CODE	PAGE NUMBER	TOTAL No OF PAGES

Th 3 ANSWER SHEET

Question	Basic formulas used	Analytical results	Numerical results	Marking guideline
1		$\leq v_z(z) \leq$		1.5
2		$L_c =$	$L_c =$	1.5
3		$N_c(H) =$		2.5
4		$H_n =$ $E_n =$	$H_1 =$ μm $E_1 =$ eV	2.5
5		$t_q =$ $L_q =$	$t_q =$ $L_q =$	2.0

PLANCK'S CONSTANT IN THE LIGHT OF AN INCANDESCENT LAMP

In 1900 Planck introduced the hypothesis that light is emitted by matter in the form of quanta of energy $h\nu$. In 1905 Einstein extended this idea proposing that once emitted, the energy quantum remains intact as a quantum of light (that later received the name photon). Ordinary light is composed of an enormous number of photons on each wave front. They remain masked in the wave, just as individual atoms are in bulk matter, but h – the Planck's constant – reveals their presence. The purpose of this experiment is to measure Planck's constant.

A body not only emits, it can also absorb radiation arriving from outside. Black body is the name given to a body that can absorb all radiation incident upon it, for any wavelength. It is a full radiator. Referring to electromagnetic radiation, black bodies absorb everything, reflect nothing, and emit everything. Real bodies are not completely black; the ratio between the energy emitted by a body and the one that would be emitted by a black body at the same temperature, is called emissivity, ε , usually depending on the wavelength.

Planck found that the power density radiated by a body at absolute temperature T in the form of electromagnetic radiation of wavelength λ can be written as

$$u_\lambda = \varepsilon \frac{c_1}{\lambda^5 (e^{c_2/\lambda T} - 1)} \quad (1)$$

where c_1 and c_2 are constants. In this question we ask you to determine c_2 experimentally, which is proportional to h .

For emission at small λ , far at left of the maxima in Figure F-1, it is permissible to drop the -1 from the denominator of Eq. (1), that reduces to

$$u_\lambda = \varepsilon \frac{c_1}{\lambda^5 e^{c_2/\lambda T}} \quad (2)$$

The basic elements of this experimental question are sketched in Fig. F-2.

- The emitter body is the tungsten filament of an incandescent lamp A that emits a wide range of λ 's, and whose luminosity can be varied.
- The test tube B contains a liquid filter that only transmits a thin band of the visible spectrum around a value λ_0 (see Fig. F-3). More information on the filter properties will be found in page 5.
- Finally, the transmitted radiation falls upon a photo resistor C (also known as LDR, the acronym of Light Dependent Resistor). Some properties of the LDR will be described in page 6.

The LDR resistance R depends on its illumination, E , which is proportional to the filament power energy density

$$\left. \begin{array}{l} E \propto u_{\lambda_0} \\ R \propto E^{-\gamma} \end{array} \right\} \Rightarrow R \propto u_{\lambda_0}^{-\gamma}$$

where the dimensionless parameter γ is a property of the LDR that will be determined in the experiment. For this setup we finally obtain a relation between the LDR resistance R and the filament temperature T

$$R = c_3 e^{c_2\gamma/\lambda_0 T} \quad (3)$$

that we will use in page 6. In this relation c_3 is an unknown proportionality constant. By measuring R as a function on T one can obtain c_2 , the objective of this experimental question.

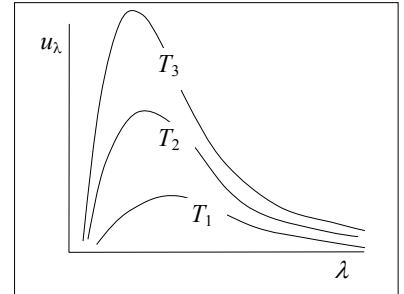

F-1

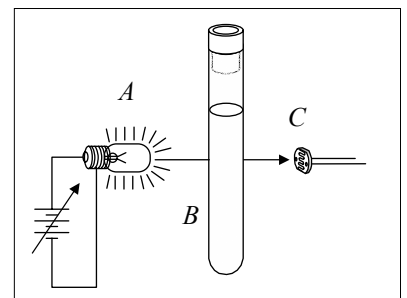

F-2

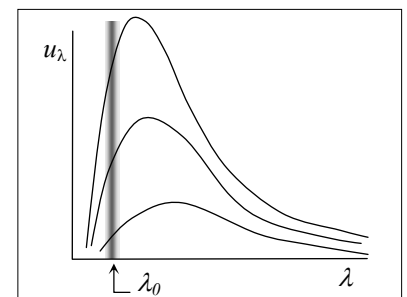

F-3

DESCRIPTION OF THE APPARATUS

The components of the apparatus are shown in Fig. F-4, which also includes some indications for its setup. Check now that all the components are available, but refrain for making any manipulation on them until reading the instructions in the next page.

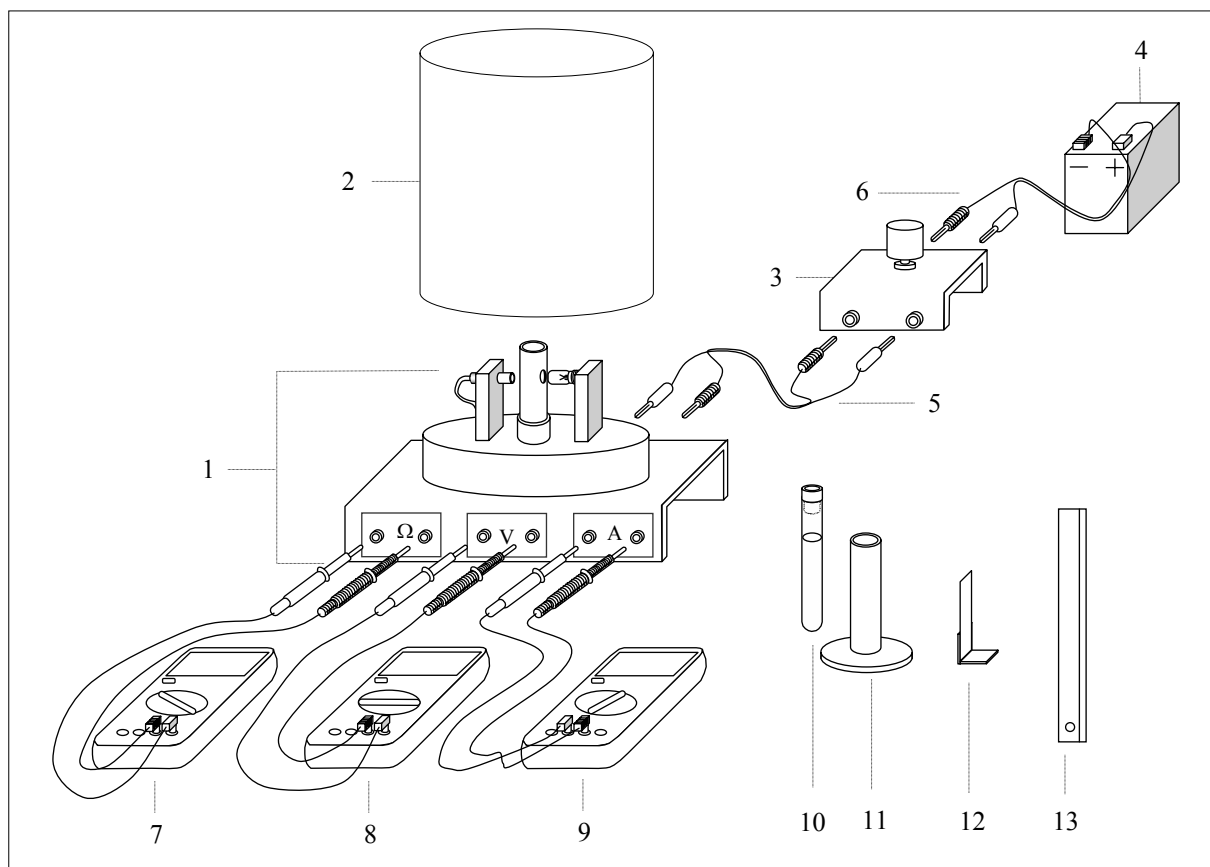

F-4

EQUIPMENT:

1. Platform. It has a disk on the top that holds a support for the LDR, a support for the tube and a support for an electric lamp of 12 V, 0.1 A.
2. Protecting cover.
3. 10 turns and 1 k Ω potentiometer.
4. 12 V battery.
5. Red and black wires with plugs at both ends to connect platform to potentiometer.
6. Red and black wires with plugs at one end and sockets for the battery at the other end.
7. Multimeter to work as ohmmeter.
8. Multimeter to work as voltmeter.
9. Multimeter to work as ammeter.
10. Test tube with liquid filter.
11. Stand for the test tube.
12. Grey filter.
13. Ruler.

An abridged set of instructions for the use of multimeters, along with information on the least squares method, is provided in a separate page.

SETTING UP THE EQUIPMENT

Follow these instructions:

- Carefully make the electric connections as indicated in Fig. F-4, but do not plug the wires 6 to the potentiometer.
- By looking at Fig. F-5, follow the steps indicated below:

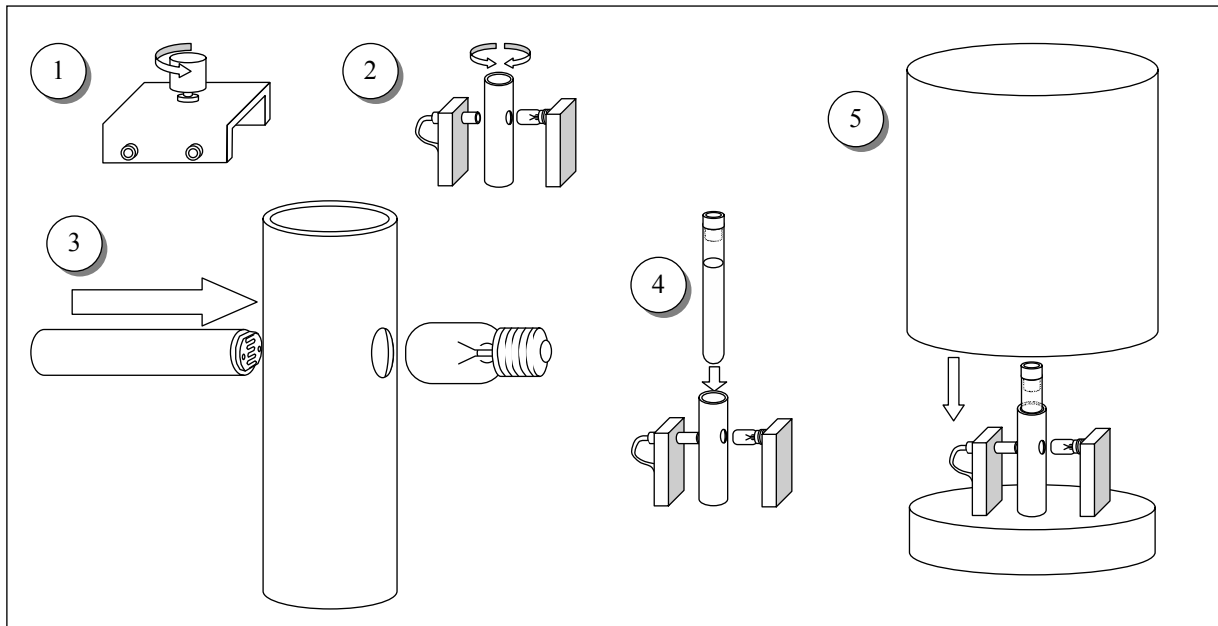

F-5

1. Turn the potentiometer knob anticlockwise until reaching the end.
2. Turn slowly the support for the test tube so that one of the lateral holes is in front of the lamp and the other in front of the LDR.
3. Bring the LDR nearer to the test tube support until making a light touch with its lateral hole. It is advisable to orient the LDR surface as indicated in Fig. F-5.
4. Insert the test tube into its support.
5. Put the cover onto the platform to protect from the outside light. Be sure to keep the LDR in total darkness for at least 10 minutes before starting the measurements of its resistance. This is a cautionary step, as the resistance value at darkness is not reached instantaneously.

Task 1

Draw in Answer Sheet 1 the complete electric circuits in the boxes and between the boxes, when the circuit is fully connected. Please, take into account the indications contained in Fig. F-4 to make the drawings.

Measurement of the filament temperature

The electric resistance R_B of a conducting filament can be given as

$$R_B = \rho \frac{l}{S} \quad (4)$$

where ρ is the resistivity of the conductor, l is the length and S the cross section of the filament.

This resistance depends on the temperature due to different causes such as:

- Metal resistivity increases with temperature. For tungsten and for temperatures in the range 300 K to 3655 K, it can be given by the empirical expression, valid in SI units,

$$T = 3.05 \cdot 10^8 \rho^{0.83} \quad (5)$$

- Thermal dilatation modifies the filament's length and section. However, its effects on the filament resistance will be negligible small in this experiment.

From (4) and (5) and neglecting dilatations one gets

$$T = a R_B^{0.83} \quad (6)$$

- Therefore, to get T it is necessary to determine a . This can be achieved by measuring the filament resistance $R_{B,0}$ at ambient temperature T_0 .

Task 2

- Measure with the multimeter the ambient temperature T_0 .
- It is not a good idea to use the ohmmeter to measure the filament resistance $R_{B,0}$ at T_0 because it introduces a small unknown current that increases the filament temperature. Instead, to find $R_{B,0}$ connect the battery to the potentiometer and make a sufficient number of current readings for voltages from the lowest values attainable up to 1 V. (It will prove useful to make at least 15 readings below 100 mV.) At the end, leave the potentiometer in the initial position and disconnect one of the cables from battery to potentiometer.

Find R_B for each pair of values of V and I , translate these values into the Table for Task 2,b) in the Answer Sheets. Indicate there the lowest voltage that you can experimentally attain. Draw a graph and represent R_B in the vertical axis against I .

- After inspecting the graphics obtained at b), select an appropriate range of values to make a linear fit to the data suitable for extrapolating to the ordinate at the origin, $R_{B,0}$. Write the selected values in the Table for Task 2, c) in the Answer Sheets. Finally, obtain $R_{B,0}$ and $\Delta R_{B,0}$.
- Compute the numerical values of a and Δa for $R_{B,0}$ in Ω and T_0 in K using (6).

OPTICAL PROPERTIES OF THE FILTER

The liquid filter in the test tube is an aqueous solution of copper sulphate (II) and Orange (II) aniline dye. The purpose of the salt is to absorb the infrared radiation emitted by the filament.

The filter transmittance (transmitted intensity/incident intensity) is shown in Figure F-6 versus the wavelength.

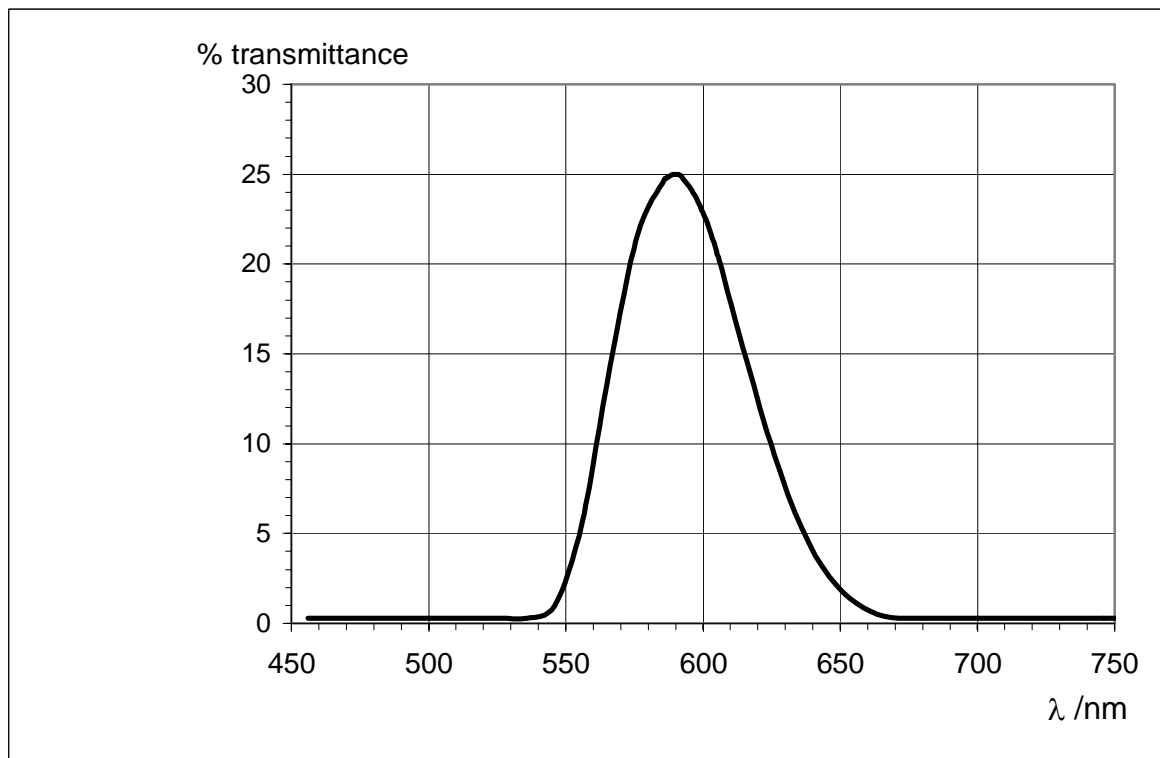

F-6

Task 3

Determine λ_0 and $\Delta\lambda$ from Fig. F-6.

Note: $2 \Delta\lambda$ is the total width at half height and λ_0 the wavelength at the maximum.

PROPERTIES OF THE LDR

The material which composes the LDR is non conducting in darkness conditions. By illuminating it some charge carriers are activated allowing some flow of electric current through it. In terms of the resistance of the LDR one can write the following relation

$$R = bE^{-\gamma} \quad (7)$$

where b is a constant that depends on the composition and geometry of the LDR and γ is a dimensionless parameter that measures the variation of the resistance with the illumination E produced by the incident radiation. Theoretically, an ideal LDR would have $\gamma = 1$, however many factors intervene, so that in the real case $\gamma < 1$.

It is necessary to determine γ . This is achieved by measuring a pair R and E (Fig. F-7) and then introducing between the lamp and the tube the grey filter F (Fig. F-8) whose transmittance is known to be 51.2 %, and we consider free of error. This produces an illumination $E' = 0.51 E$. After measuring the resistance R' corresponding to this illumination, we have

$$R = bE^{-\gamma} \quad ; \quad R' = b(0.512 E)^{-\gamma}$$

From this

$$\ln \frac{R}{R'} = \gamma \ln 0.512 \quad (8)$$

Do not carry out this procedure until arriving at part b) of task 4 below.

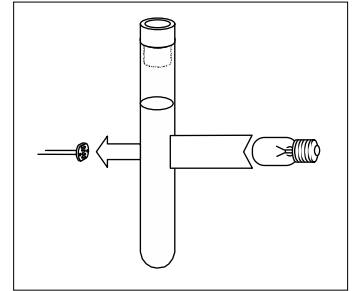

F-7

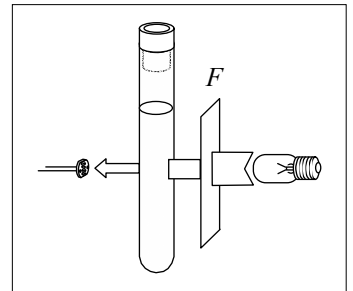

F-8

Task 4

- Check that the LDR remained in complete darkness for at least 10 minutes before starting this part. Connect the battery to the potentiometer and, rotating the knob very slowly, increase the lamp voltage. Read the pairs of values of V and I for V in the range between 9.50 V and 11.50 V, and obtain the corresponding LDR resistances R . (It will be useful to make at least 12 readings). Translate all these values to a table in the Answer Sheet. To deal with the delay in the LDR response, we recommend the following procedure: Once arrived at $V > 9.5$ V, wait 10 min approximately before making the first reading. Then wait 5 min for the second one, and so on. Before doing any further calculation go to next step.
- Once obtained the lowest value of the resistance R , open the protecting cover, put the grey filter as indicated in F-9, cover again - as soon as possible - the platform and record the new LDR resistance R' . Using these data in (8) compute γ and $\Delta\gamma$.
- Modify Eq. (3) to display a linear dependence of $\ln R$ on $R_B^{-0.83}$. Write down that equation there and label it as (9).
- Using now the data from a), work out a table that will serve to plot Eq. (9).
- Make the graphics plot and, knowing that $c_2 = hc/k$, compute h and Δh by any method (you are allowed to use statistical functions of the calculators provided by the organization).

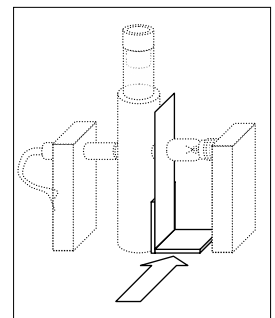

F-9

(Speed of light, $c = 2.998 \cdot 10^8$ m s⁻¹ ; Boltzmann constant, $k = 1.381 \cdot 10^{-23}$ J K⁻¹)

36th International Physics Olympiad. Salamanca. Spain. Experimental Competition, 7 July 2005





COUNTRY NUMBER	COUNTRY CODE	STUDENT NUMBER	PAGE NUMBER	TOTAL No OF PAGES

Answer sheet 1

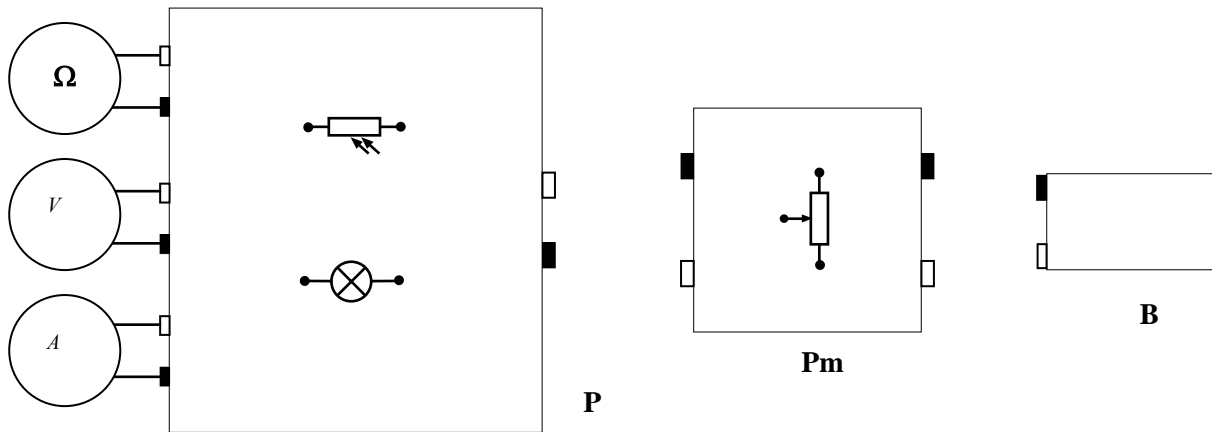
TASK 1 (2.0 points)

Draw the electric connections in the boxes and between boxes below.



Photoresistor	
Incandescent Bulb	
Potentiometer	
Red socket	
Black socket	

Ω	Ohmmeter
V	Voltmeter
A	Ammeter
P	Platform
Pm	Potentiometer
B	Battery

36th International Physics Olympiad. Salamanca. Spain. Experimental Competition, 7 July 2005

COUNTRY NUMBER	COUNTRY CODE	STUDENT NUMBER	PAGE NUMBER	TOTAL No OF PAGES

Answer sheet 2

TASK 2

a) (1.0 points)

$T_0 =$

b) (2.0 points)

V	I	R_B

$V_{min} =$ *
* This is a characteristic of your apparatus. You can't go below it.

36th International Physics Olympiad. Salamanca. Spain. Experimental Competition, 7 July 2005

COUNTRY NUMBER	COUNTRY CODE	STUDENT NUMBER	PAGE NUMBER	TOTAL No OF PAGES

Answer sheet 3

TASK 2

c) (2.5 points)

V	I	R_B

$R_{B0} =$	$\Delta R_{B0} =$
------------	-------------------

d) (1.0 points)

$a =$	$\Delta a =$
-------	--------------

TASK 3 (1.0 points)

$\lambda_0 =$	$\Delta \lambda =$
---------------	--------------------

36th International Physics Olympiad. Salamanca. Spain. Experimental Competition, 7 July 2005

COUNTRY NUMBER	COUNTRY CODE	STUDENT NUMBER	PAGE NUMBER	TOTAL No OF PAGES

Answer sheet 4

TASK 4

a) (2.0 points)

V	I	R

b) (1.5 points)

$R =$	$\gamma =$
$R' =$	$\Delta\gamma =$

c) (1.0 points)

Eq. (9)

36th International Physics Olympiad. Salamanca. Spain. Experimental Competition, 7 July 2005

COUNTRY NUMBER	COUNTRY CODE	STUDENT NUMBER	PAGE NUMBER	TOTAL No OF PAGES

Answer sheet 5

TASK 4

d) (3.0 points)

V	I		R	

e) (3.0 points)

$h =$	$\Delta h =$
-------	--------------

Th1 AN ILL FATED SATELLITE SOLUTION

1.1 and 1.2

$$\left. \begin{aligned} G \frac{M_T m}{r_0^2} &= m \frac{v_0^2}{r_0} \\ v_0 &= \frac{2\pi r_0}{T_0} \\ g &= \frac{GM_T}{R_T^2} \end{aligned} \right\} \Rightarrow \left\{ \begin{aligned} r_0 &= \left(\frac{g R_T^2 T_0^2}{4\pi^2} \right)^{1/3} \Rightarrow r_0 = 4.22 \cdot 10^7 \text{ m} \\ v_0 &= R_T \sqrt{\frac{g}{r_0}} \Rightarrow v_0 = 3.07 \cdot 10^3 \text{ m/s} \end{aligned} \right.$$

1.3

$$L_0 = r_0 m v_0 = \frac{g R_T^2}{v_0^2} m v_0 \Rightarrow \boxed{L_0 = \frac{m g R_T^2}{v_0}}$$

$$E_0 = \frac{1}{2} m v_0^2 - G \frac{M_T m}{r_0} = \frac{1}{2} m v_0^2 - \frac{g R_T^2 m}{r_0} = \frac{1}{2} m v_0^2 - m v_0^2 \Rightarrow \boxed{E_0 = -\frac{1}{2} m v_0^2}$$

2.1

The value of the *semi-latus-rectum* l is obtained taking into account that the orbital angular momentum is the same in both orbits. That is

$$l = \frac{L_0^2}{G M_T m^2} = \frac{m^2 g^2 R_T^4}{v_0^2} \frac{1}{g R_T^2 m^2} = \frac{g R_T^2}{v_0^2} = r_0 \Rightarrow \boxed{l = r_0}$$

The eccentricity value is

$$\varepsilon^2 = 1 + \frac{2 E L_0^2}{G^2 M_T^2 m^3}$$

where E is the new satellite mechanical energy

$$E = \frac{1}{2} m (v_0^2 + \Delta v^2) - G \frac{M_T m}{r_0} = \frac{1}{2} m \Delta v^2 + E_0 = \frac{1}{2} m \Delta v^2 - \frac{1}{2} m v_0^2$$

that is

$$E = \frac{1}{2} m v_0^2 \left(\frac{\Delta v^2}{v_0^2} - 1 \right) = \frac{1}{2} m v_0^2 (\beta^2 - 1)$$

Combining both, one gets $\boxed{\varepsilon = \beta}$

This is an elliptical trajectory because $\varepsilon = \beta < 1$.

2.2

The initial and final orbits cross at P, where the satellite engine fired instantaneously (see Figure 4). At this point

$$r(\theta = \alpha) = r_0 = \frac{r_0}{1 - \beta \cos \alpha} \Rightarrow \boxed{\alpha = \frac{\pi}{2}}$$

2.3

From the trajectory expression one immediately obtains that the maximum and minimum values of r correspond to $\theta = 0$ and $\theta = \pi$ respectively (see Figure 4). Hence, they are given by

$$r_{\max} = \frac{l}{1 - \varepsilon} \quad r_{\min} = \frac{l}{1 + \varepsilon}$$

that is

$$\boxed{r_{\max} = \frac{r_0}{1 - \beta}} \quad \text{and} \quad \boxed{r_{\min} = \frac{r_0}{1 + \beta}}$$

For $\beta = 1/4$, one gets

$$\boxed{r_{\max} = 5.63 \cdot 10^7 \text{ m}; \quad r_{\min} = 3.38 \cdot 10^7 \text{ m}}$$

The distances r_{\max} and r_{\min} can also be obtained from mechanical energy and angular momentum conservation, taking into account that \vec{r} and \vec{v} are orthogonal at apogee and at perigee

$$E = \frac{1}{2} m v_0^2 (\beta^2 - 1) = \frac{1}{2} m v^2 - \frac{g R_T^2 m}{r}$$

$$L_0 = \frac{m g R_T^2}{v_0} = m v r$$

What remains of them, after eliminating v , is a second-degree equation whose solutions are r_{\max} and r_{\min} .

2.4

By the Third Kepler Law, the period T in the new orbit satisfies that

$$\frac{T^2}{a^3} = \frac{T_0^2}{r_0^3}$$

where a , the semi-major axis of the ellipse, is given by

$$a = \frac{r_{\max} + r_{\min}}{2} = \frac{r_0}{1 - \beta^2}$$

Therefore

$$\boxed{T = T_0 (1 - \beta^2)^{-3/2}}$$

For $\beta = 1/4$

$$\boxed{T = T_0 \left(\frac{15}{16} \right)^{-3/2} = 26.4 \text{ h}}$$

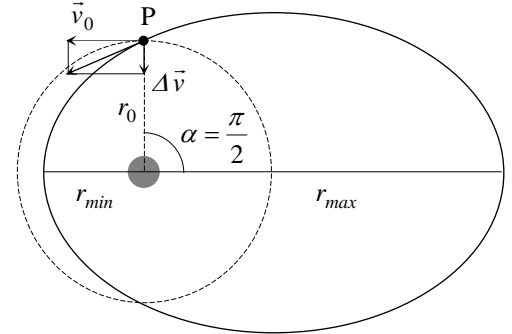

Figure 4

3.1

Only if the satellite follows an open trajectory it can escape from the Earth gravity attraction. Then, the orbit eccentricity has to be equal or larger than one. The minimum boost corresponds to a parabolic trajectory, with $\varepsilon = 1$

$$\varepsilon = \beta \quad \Rightarrow \quad \boxed{\beta_{esc} = 1}$$

This can also be obtained by using that the total satellite energy has to be zero to reach infinity ($E_p = 0$) without residual velocity ($E_k = 0$)

$$E = \frac{1}{2} m v_0^2 (\beta_{esc}^2 - 1) = 0 \quad \Rightarrow \quad \beta_{esc} = 1$$

This also arises from $T = \infty$ or from $r_{max} = \infty$.

3.2

Due to $\varepsilon = \beta_{esc} = 1$, the polar parabola equation is

$$r = \frac{l}{1 - \cos \theta}$$

where the semi-latus-rectum continues to be $l = r_0$. The minimum Earth - satellite distance corresponds to $\theta = \pi$, where

$$\boxed{r'_{min} = \frac{r_0}{2}}$$

This also arises from energy conservation (for $E = 0$) and from the equality between the angular momenta (L_0) at the initial point P and at maximum approximation, where \vec{r} and \vec{v} are orthogonal.

4.1

If the satellite escapes to infinity with residual velocity v_∞ , by energy conservation

$$E = \frac{1}{2} m v_0^2 (\beta^2 - 1) = \frac{1}{2} m v_\infty^2 \quad \Rightarrow$$

$$\boxed{v_\infty = v_0 (\beta^2 - 1)^{1/2}}$$

4.2

As $\varepsilon = \beta > \beta_{esc} = 1$ the satellite trajectory will be a hyperbola.

The satellite angular momentum is the same at P than at the point where its residual velocity is v_∞ (Figure 5), thus

$$m v_0 r_0 = m v_\infty b$$

So

$$b = r_0 \frac{v_0}{v_\infty} \quad \Rightarrow \quad \boxed{b = r_0 (\beta^2 - 1)^{-1/2}}$$

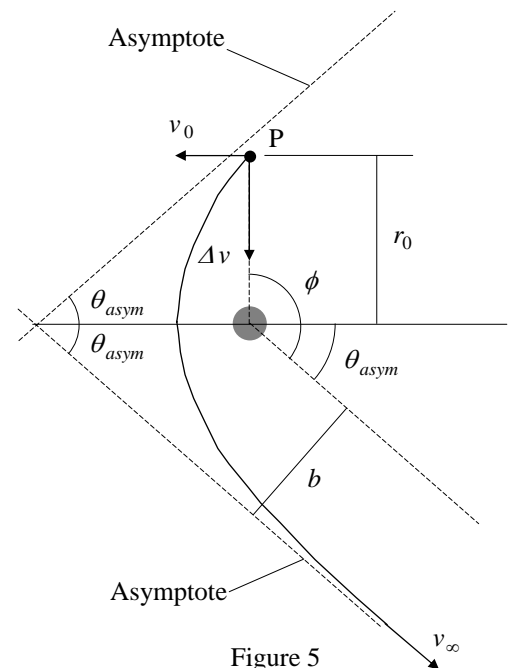

Figure 5

4.3

The angle between each asymptote and the hyperbola axis is that appearing in its polar equation in the limit $r \rightarrow \infty$. This is the angle for which the equation denominator vanishes

$$1 - \beta \cos \theta_{asym} = 0 \quad \Rightarrow \quad \theta_{asym} = \cos^{-1} \left(\frac{1}{\beta} \right)$$

According to Figure 5

$$\phi = \frac{\pi}{2} + \theta_{asym} \quad \Rightarrow \quad \boxed{\phi = \frac{\pi}{2} + \cos^{-1} \left(\frac{1}{\beta} \right)}$$

For $\beta = \frac{3}{2} \beta_{esc} = \frac{3}{2}$, one gets $\boxed{\phi = 138^\circ = 2.41 \text{ rad}}$

Th 1 ANSWER SHEET

Question	Basic formulas and ideas used	Analytical results	Numerical results	Marking guideline
1.1	$G \frac{M_T m}{r_0^2} = m \frac{v_0^2}{r_0}$		$r_0 = 4.22 \cdot 10^7 \text{ m}$	0.3
1.2	$v_0 = \frac{2\pi r_0}{T_0}$ $g = \frac{GM_T}{R_T^2}$	$v_0 = R_T \sqrt{\frac{g}{r_0}}$	$v_0 = 3.07 \cdot 10^3 \text{ m/s}$	0.3 + 0.1
1.3	$\vec{L} = m \vec{r} \times \vec{v}$ $E = \frac{1}{2} m v^2 - G \frac{Mm}{r}$	$L_0 = \frac{mgR_T^2}{v_0}$		0.4
		$E_0 = -\frac{1}{2} m v_0^2$		0.4
2.1	Hint on the conical curves	$l = r_0$ $\varepsilon = \beta$		0.4 0.5
2.2			$\alpha = \frac{\pi}{2}$	1.0
2.3	Results of 2.1, or conservation of E and L	$r_{\max} = \frac{r_0}{1 - \beta}$ $r_{\min} = \frac{r_0}{1 + \beta}$	$r_{\max} = 5.63 \cdot 10^7 \text{ m}$ $r_{\min} = 3.38 \cdot 10^7 \text{ m}$	1.0 + 0.2
2.4	Third Kepler's Law	$T = T_0 (1 - \beta^2)^{-3/2}$	$T = 26.4 \text{ h}$	0.5 + 0.2
3.1	$\varepsilon = 1, E = 0, T = \infty$ or $r_{\max} = \infty$		$\beta_{\text{esc}} = 1$	0.5
3.2	$\varepsilon = 1$ and results of 2.1	$r'_{\min} = \frac{r_0}{2}$		1.0
4.1	Conservation of E	$v_{\infty} = v_0 (\beta^2 - 1)^{1/2}$		1.0
4.2	Conservation of L	$b = r_0 (\beta^2 - 1)^{-1/2}$		1.0
4.3	Hint on the conical curves	$\phi = \frac{\pi}{2} + \cos^{-1} \left(\frac{1}{\beta} \right)$	$\phi = 138^\circ = 2.41 \text{ rad}$	1.0 + 0.2

Th 2 ABSOLUTE MEASUREMENTS OF ELECTRICAL QUANTITIES

SOLUTION

1. After some time t , the normal to the coil plane makes an angle ωt with the magnetic field $\vec{B}_0 = B_0 \vec{i}$. Then, the magnetic flux through the coil is

$$\phi = N \vec{B}_0 \cdot \vec{S}$$

where the vector surface \vec{S} is given by $\vec{S} = \pi a^2 (\cos \omega t \vec{i} + \sin \omega t \vec{j})$

Therefore $\phi = N \pi a^2 B_0 \cos \omega t$

The induced electromotive force is

$$\mathcal{E} = -\frac{d\phi}{dt} \quad \Rightarrow \quad \boxed{\mathcal{E} = N \pi a^2 B_0 \omega \sin \omega t}$$

The instantaneous power is $P = \mathcal{E}^2 / R$, therefore

$$\boxed{\langle P \rangle = \frac{(N \pi a^2 B_0 \omega)^2}{2R}}$$

where we used $\langle \sin^2 \omega t \rangle = \frac{1}{T} \int_0^T \sin^2 \omega t dt = \frac{1}{2}$

2. The total field at the center the coil at the instant t is

$$\vec{B}_t = \vec{B}_0 + \vec{B}_i$$

where \vec{B}_i is the magnetic field due to the induced current $\vec{B}_i = B_i (\cos \omega t \vec{i} + \sin \omega t \vec{j})$

with $B_i = \frac{\mu_0 N I}{2a}$ and $I = \mathcal{E} / R$

Therefore $B_i = \frac{\mu_0 N^2 \pi a B_0 \omega}{2R} \sin \omega t$

The mean values of its components are

$$\langle B_{ix} \rangle = \frac{\mu_0 N^2 \pi a B_0 \omega}{2R} \langle \sin \omega t \cos \omega t \rangle = 0$$

$$\langle B_{iy} \rangle = \frac{\mu_0 N^2 \pi a B_0 \omega}{2R} \langle \sin^2 \omega t \rangle = \frac{\mu_0 N^2 \pi a B_0 \omega}{4R}$$

And the mean value of the total magnetic field is

$$\langle \vec{B}_t \rangle = B_0 \vec{i} + \frac{\mu_0 N^2 \pi a B_0 \omega}{4R} \vec{j}$$

The needle orients along the mean field, therefore

$$\tan \theta = \frac{\mu_0 N^2 \pi a \omega}{4R}$$

Finally, the resistance of the coil measured by this procedure, in terms of θ , is

$$R = \frac{\mu_0 N^2 \pi a \omega}{4 \tan \theta}$$

3. The force on a unit positive charge in a disk is radial and its modulus is

$$|\vec{v} \times \vec{B}| = vB = \omega r B$$

where B is the magnetic field at the center of the coil

$$B = N \frac{\mu_0 I}{2a}$$

Then, the electromotive force (e.m.f.) induced on each disk by the magnetic field B is

$$\mathcal{E}_D = \mathcal{E}_{D'} = B \omega \int_0^b r dr = \frac{1}{2} B \omega b^2$$

Finally, the induced e.m.f. between 1 and 4 is $\mathcal{E} = \mathcal{E}_D + \mathcal{E}_{D'}$

$$\mathcal{E} = N \frac{\mu_0 b^2 \omega I}{2a}$$

4. When the reading of G vanishes, $I_G = 0$ and Kirchoff laws give an immediate answer. Then we have

$$\mathcal{E} = I R \quad \Rightarrow \quad R = N \frac{\mu_0 b^2 \omega}{2a}$$

5. The force per unit length f between two indefinite parallel straight wires separated by a distance h is.

$$f = \frac{\mu_0 I_1 I_2}{2\pi h}$$

for $I_1 = I_2 = I$ and length $2\pi a$, the force F induced on C_2 by the neighbor coils C_1 is

$$F = \frac{\mu_0 a}{h} I^2$$

6. In equilibrium

$$mgx = 4Fd$$

Then

$$mgx = \frac{4\mu_0 ad}{h} I^2 \quad (1)$$

so that

$$I = \left(\frac{mgx}{4\mu_0 ad} \right)^{1/2}$$

7. The balance comes back towards the equilibrium position for a little angular deviation $\delta\varphi$ if the gravity torques with respect to the fulcrum O are greater than the magnetic torques.

$$Mgl \sin\delta\varphi + mgx \cos\delta\varphi > 2\mu_0 aI^2 \left(\frac{1}{h-\delta z} + \frac{1}{h+\delta z} \right) d \cos\delta\varphi$$

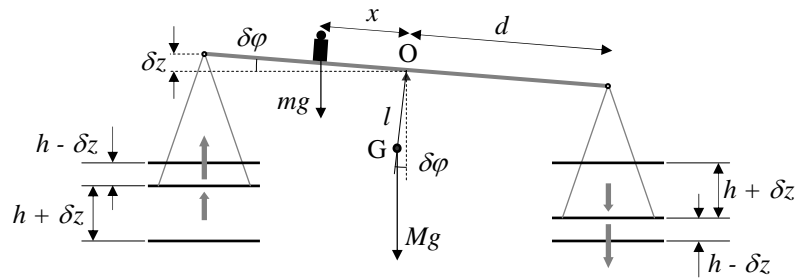

Therefore, using the suggested approximation

$$Mgl \sin\delta\varphi + mgx \cos\delta\varphi > \frac{4\mu_0 adI^2}{h} \left(1 + \frac{\delta z^2}{h^2} \right) \cos\delta\varphi$$

Taking into account the equilibrium condition (1), one obtains

$$Mgl \sin\delta\varphi > mgx \frac{\delta z^2}{h^2} \cos\delta\varphi$$

Finally, for $\tan\delta\varphi \approx \sin\delta\varphi = \frac{\delta z}{d}$

$$\delta z < \frac{Mlh^2}{mxd} \Rightarrow \boxed{\delta z_{\max} = \frac{Mlh^2}{mxd}}$$

Th 2 ANSWER SHEET

Question	Basic formulas and ideas used	Analytical results	Marking guideline
1	$\Phi = N \vec{B}_0 \cdot \vec{S}$ $\mathcal{E} = -\frac{d\Phi}{dt}$ $P = \frac{\mathcal{E}^2}{R}$	$\mathcal{E} = N\pi a^2 B_0 \omega \sin \omega t$ $\langle P \rangle = \frac{(N\pi a^2 B_0 \omega)^2}{2R}$	0.5 1.0
2	$\vec{B} = \vec{B}_0 + \vec{B}_i$ $B_i = \frac{\mu_0 N}{2a} I$ $\tan \theta = \frac{\langle B_y \rangle}{\langle B_x \rangle}$	$R = \frac{\mu_0 N^2 \pi a \omega}{4 \tan \theta}$	2.0
3	$\vec{E} = \vec{v} \times \vec{B}$ $v = \omega r$ $B = N \frac{\mu_0 I}{2a}$ $\mathcal{E} = \int_0^b \vec{E} \cdot d\vec{r}$	$\mathcal{E} = N \frac{\mu_0 b^2 \omega I}{2a}$	2.0
4	$\mathcal{E} = RI$	$R = N \frac{\mu_0 b^2 \omega}{2a}$	0.5
5	$f = \frac{\mu_0 I I'}{2\pi h}$	$F = \frac{\mu_0 a}{h} I^2$	1.0
6	$mgx = 4Fd$	$I = \left(\frac{mghx}{4\mu_0 ad} \right)^{1/2}$	1.0
7	$\Gamma_{grav} > \Gamma_{mag}$	$\delta z_{\max} = \frac{Mlh^2}{mxd}$	2.0

Th3 QUANTUM EFFECTS OF GRAVITY

SOLUTION

1. The only neutrons that will survive absorption at A are those that cannot cross H . Their turning points will be below H . So that, for a neutron entering to the cavity at height z with vertical velocity v_z , conservation of energy implies

$$\frac{1}{2} M v_z^2 + M g z \leq M g H \quad \Rightarrow \quad \boxed{-\sqrt{2g(H-z)} \leq v_z(z) \leq \sqrt{2g(H-z)}}$$

2. The cavity should be long enough to ensure the absorption of all neutrons with velocities outside the allowed range. Therefore, neutrons have to reach its maximum height at least once within the cavity. The longest required length corresponds to neutrons that enter at $z = H$ with $v_z = 0$ (see the figure). Calling t_f to their time of fall

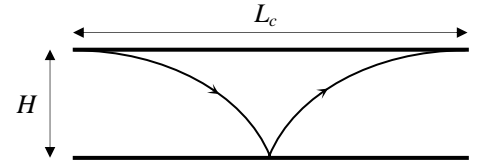

$$\left. \begin{aligned} L_c &= v_x 2t_f \\ H &= \frac{1}{2} g t_f^2 \end{aligned} \right\} \Rightarrow \quad \boxed{L_c = 2v_x \sqrt{\frac{2H}{g}}} \quad \boxed{L_c = 6.4 \text{ cm}}$$

3. The rate of transmitted neutrons entering at a given height z , per unit height, is proportional to the range of allowed velocities at that height, ρ being the proportionality constant

$$\frac{dN_c(z)}{dz} = \rho [v_{z,\max}(z) - v_{z,\min}(z)] = 2\rho \sqrt{2g(H-z)}$$

The total number of transmitted neutrons is obtained by adding the neutrons entering at all possible heights. Calling $y = z/H$

$$\begin{aligned} N_c(H) &= \int_0^H dN_c(z) = \int_0^H 2\rho \sqrt{2g(H-z)} dz = 2\rho \sqrt{2g} H^{3/2} \int_0^1 (1-y)^{1/2} dy = 2\rho \sqrt{2g} H^{3/2} \left[-\frac{2}{3} (1-y)^{3/2} \right]_0^1 \\ \Rightarrow \quad \boxed{N_c(H) &= \frac{4}{3} \rho \sqrt{2g} H^{3/2}} \end{aligned}$$

4. For a neutron falling from a height H , the action over a bouncing cycle is twice the action during the fall or the ascent

$$S = 2 \int_0^H p_z dz = 2M \sqrt{2g} H^{3/2} \int_0^1 (1-y)^{1/2} dy = \frac{4}{3} M \sqrt{2g} H^{3/2}$$

Using the BS quantization condition

$$S = \frac{4}{3} M \sqrt{2g} H^{3/2} = n h \quad \Rightarrow \quad \boxed{H_n = \left(\frac{9 h^2}{32 M^2 g} \right)^{1/3} n^{2/3}}$$

The corresponding energy levels (associated to the vertical motion) are

$$E_n = M g H_n \quad \Rightarrow \quad \boxed{E_n = \left(\frac{9 M g^2 h^2}{32} \right)^{1/3} n^{2/3}}$$

Numerical values for the first level:

$$H_1 = \left(\frac{9\hbar^2}{32M^2g} \right)^{1/3} = 1.65 \times 10^{-5} \text{ m} \quad \boxed{H_1 = 16.5 \text{ }\mu\text{m}}$$

$$E_1 = M g H_1 = 2.71 \times 10^{-31} \text{ J} = 1.69 \times 10^{-12} \text{ eV} \quad \boxed{E_1 = 1.69 \text{ peV}}$$

Note that H_1 is of the same order than the given cavity height, $H = 50 \text{ }\mu\text{m}$. This opens up the possibility for observing the spatial quantization when varying H .

5. The uncertainty principle says that the minimum time Δt and the minimum energy ΔE satisfy the relation $\Delta E \Delta t \geq \hbar$. During this time, the neutrons move to the right a distance

$$\Delta x = v_x \Delta t \geq v_x \frac{\hbar}{\Delta E}$$

Now, the minimum neutron energy allowed in the cavity is E_1 , so that $\Delta E \approx E_1$. Therefore, an estimation of the minimum time and the minimum length required is

$$\boxed{t_q \approx \frac{\hbar}{E_1} = 0.4 \cdot 10^{-3} \text{ s} = 0.4 \text{ ms}} \quad \boxed{L_q \approx v_x \frac{\hbar}{E_1} = 4 \cdot 10^{-3} \text{ m} = 4 \text{ mm}}$$

Th 3 ANSWER SHEET

Question	Basic formulas used	Analytical results	Numerical results	Marking guideline
1	$\frac{1}{2} M v_z^2 + M g z \leq M g H$	$-\sqrt{2g(H-z)} \leq v_z(z) \leq \sqrt{2g(H-z)}$		1.5
2	$L_c = v_x 2t_f$ $H = \frac{1}{2} g t_f^2$	$L_c = 2v_x \sqrt{\frac{2H}{g}}$	$L_c = 6.4 \text{ cm}$	1.3 + 0.2
3	$\frac{dN_c}{dz} = \rho [v_{z,\max} - v_{z,\min}]$ $N_c(H) = \int_0^H dN_c(z)$	$N_c(H) = \frac{4}{3} \rho \sqrt{2g} H^{3/2}$		2.5
4	$S = 2 \int_0^H p_z dz = nh$	$H_n = \left(\frac{9h^2}{32M^2g} \right)^{1/3} n^{2/3}$ $E_n = \left(\frac{9Mg^2h^2}{32} \right)^{1/3} n^{2/3}$	$H_1 = 16.5 \mu\text{m}$ $E_1 = 1.69 \text{ peV}$	1.6 + 0.2 0.5 + 0.2
5	$\Delta E \Delta t \geq \hbar$ $\Delta E \approx E_1$ $\Delta x = v_x \Delta t$	$t_q \approx \frac{\hbar}{E_1}$ $L_q \approx v_x \frac{\hbar}{E_1}$	$t_q \approx 0.4 \text{ ms}$ $L_q \approx 4 \text{ mm}$	1.3 + 0.2 0.3 + 0.2

PLANCK'S CONSTANT IN THE LIGHT OF AN INCANDESCENT LAMP

SOLUTION

TASK 1

Draw the electric connections in the boxes and between boxes below.

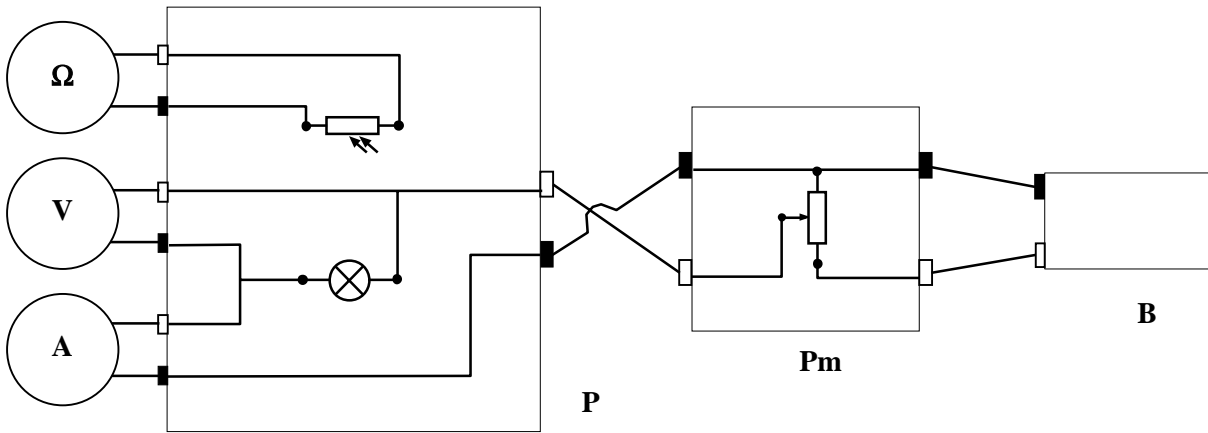

Photoresistor	
Incandescent Bulb	
Potentiometer	
Red socket	
Black socket	

Ω	Ohmmeter
V	Voltmeter
A	Ammeter
P	Platform
Pm	Potentiometer
B	Battery

TASK 2

a)

$t_0 = 24\text{ }^\circ\text{C}$	$T_0 = 297\text{ K}$	$\Delta T_0 = 1\text{ K}$
----------------------------------	----------------------	---------------------------

b)

V/mV	I/mA	R_B/Ω
21.9	1.87	11.7
30.5	2.58	11.8
34.9	2.95	11.8
37.0	3.12	11.9
40.1	3.37	11.9
43.0	3.60	11.9
47.6	3.97	12.0
51.1	4.24	12.1
55.3	4.56	12.1
58.3	4.79	12.2
61.3	5.02	12.2
65.5	5.33	12.3
67.5	5.47	12.3
73.0	5.88	12.4
80.9	6.42	12.6
85.6	6.73	12.7
89.0	6.96	12.8
95.1	7.36	12.9
111.9	8.38	13.4
130.2	9.37	13.9
181.8	11.67	15.6
220	13.04	16.9
307	15.29	20.1
447	17.68	25.1
590	19.8	29.8
730	21.5	33.9
860	23.2	37.1
960	24.4	39.3

 $V_{min} = 9.2\text{ mV}$

*

* This is a characteristic of your apparatus. You can't go below it.

 We represent R_B in the vertical axis against I .

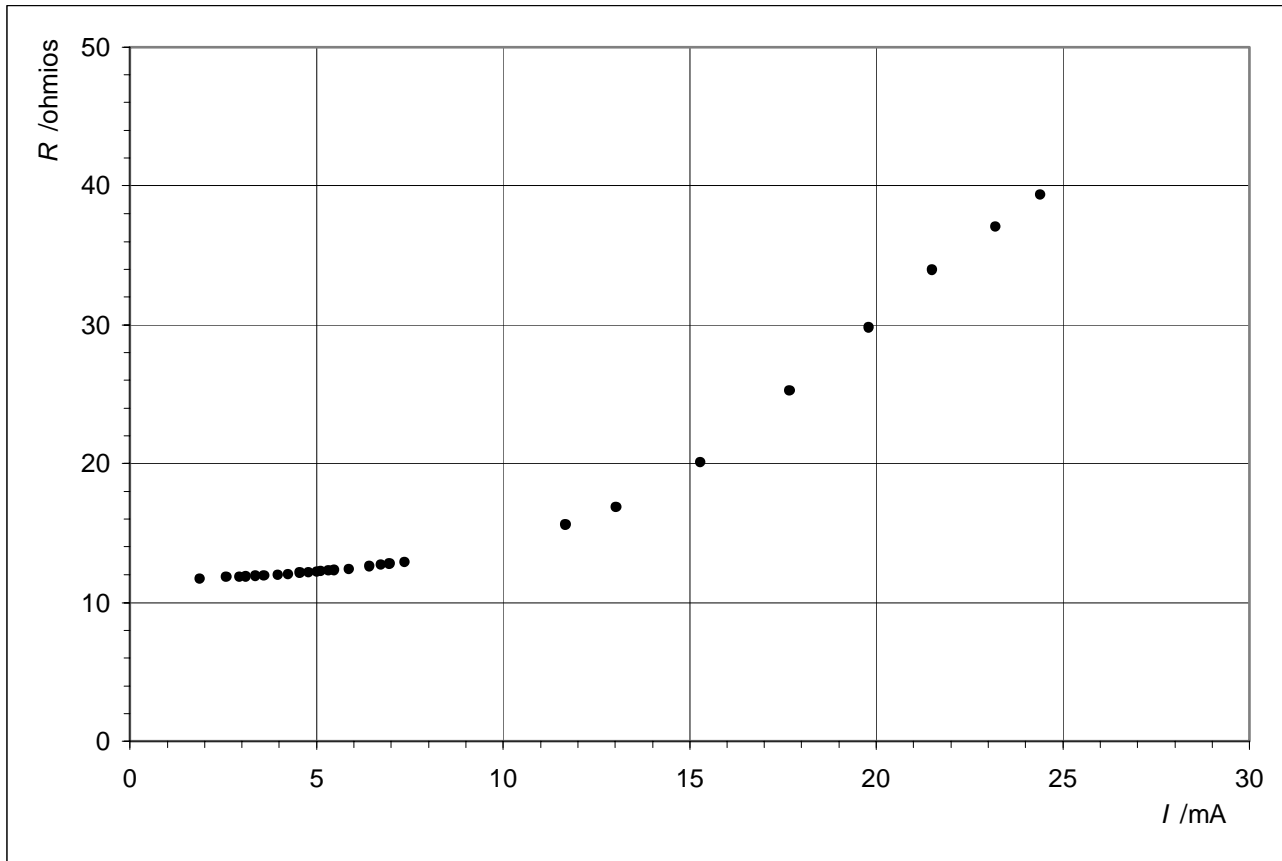



In order to work out R_{B0} , we choose the first ten readings.

TASK 2

c)

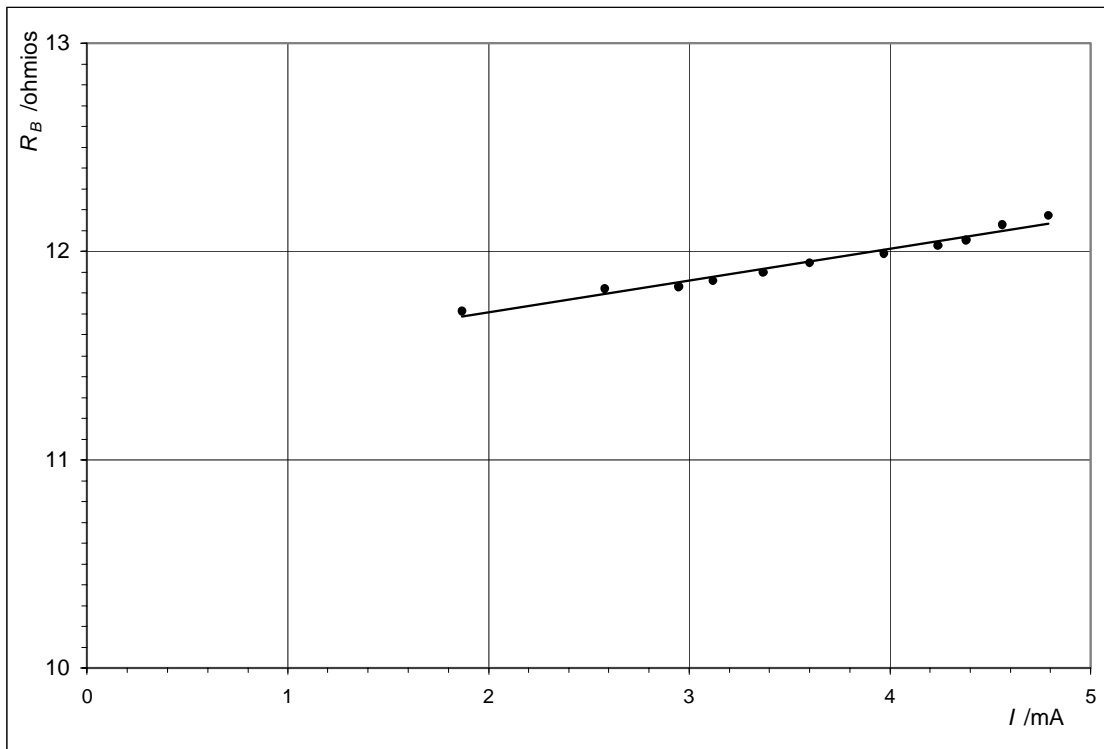
V / mV	I / mA	R_B / Ω
21.9 ± 0.1	1.87 ± 0.01	11.7 ± 0.1
30.5 ± 0.1	2.58 ± 0.01	11.8 ± 0.1
34.9 ± 0.1	2.95 ± 0.01	11.8 ± 0.1
37.0 ± 0.1	3.12 ± 0.01	11.9 ± 0.1
40.1 ± 0.1	3.37 ± 0.01	11.9 ± 0.1
43.0 ± 0.1	3.60 ± 0.01	11.9 ± 0.1
47.6 ± 0.1	3.97 ± 0.01	12.0 ± 0.1
51.1 ± 0.1	4.24 ± 0.01	12.1 ± 0.1
55.3 ± 0.1	4.56 ± 0.01	12.1 ± 0.1
58.3 ± 0.1	4.79 ± 0.01	12.2 ± 0.1



Error for R_B (We work out the error for first value, as example).

$$\Delta R_B = R_B \sqrt{\left(\frac{\Delta V}{V}\right)^2 + \left(\frac{\Delta I}{I}\right)^2} = 11.71 \sqrt{\left(\frac{0.1}{21.9}\right)^2 + \left(\frac{0.01}{1.87}\right)^2} = 0.1$$

We have worked out R_{B0} by the least squares.

$$R_{B0} = 11.4$$

$$\text{slope} = m = 0.167$$

$$\sum I^2 = 130.38$$

$$\sum I = 35.05$$

$$n = 10$$

$$\text{For axis } X : \sigma_I = \sqrt{\frac{\sum \Delta I^2}{n}} = 0.01$$

$$\text{For axis } Y : \sigma_{R_B} = \sqrt{\frac{\sum \Delta R_B^2}{n}} = 0.047$$

$$\sigma = \sqrt{\sigma_{R_B}^2 + m^2 \sigma_I^2} = \sqrt{0.1^2 + 0.167^2 \cdot 0.01^2} = 0.1$$

$$\Delta R_{B0} = \sqrt{\frac{\sigma^2 \sum I^2}{n \sum I^2 - (\sum I)^2}} = \sqrt{\frac{0.1^2 \times 130.38}{10 \cdot 130.38 - 35.05^2}} = 0.13$$

$R_{B0} = 11,4 \Omega$	$\Delta R_{B0} = 0.1 \Omega$
------------------------	------------------------------

$$d) \quad T = aR^{0.83} ; \quad a = \frac{T_0}{R_0^{0.83}} ; \quad a = \frac{297}{11.4^{0.83}} = 39.40$$

Working out the error for two methods:

Method A

$$\ln a = \ln T_0 - 0.83 \ln R_{B0} ; \quad \Delta a = a \left(\frac{\Delta T_0}{T_0} + 0.83 \frac{\Delta R_{B0}}{R_{B0}} \right) ; \quad \Delta a = 39.40 \left(\frac{1}{297} + 0.83 \frac{0.1}{11.40} \right) = 0.419 = 0.4$$

Method B

$$\text{Higher value of } a: \quad a_{\max} = \frac{T_0 + \Delta T_0}{(R_0 - \Delta R_0)^{0.83}} = \frac{297 + 1}{(11.4 - 0.1)^{0.83}} = 39.8255$$

$$\text{Smaller value of } a: \quad a_{\min} = \frac{T_0 - \Delta T_0}{(R_0 + \Delta R_0)^{0.83}} = \frac{297 - 1}{(11.4 + 0.1)^{0.83}} = 38.9863$$

$$\Delta a = \frac{a_{\max} - a_{\min}}{2} = \frac{39.8255 - 38.9863}{2} = 0.419 = 0.4$$

$a = 39.4$	$\Delta a = 0.4$
------------	------------------

TASK 3

Because of $2\Delta\lambda = 620 - 565$; $\Delta\lambda = 28$ nm

$\lambda_0 = 590$ nm	$\Delta\lambda = 28$ nm
----------------------	-------------------------

TASK 4

a)

V/V	I / mA	$R / \text{k}\Omega$
9.48	85.5	8.77
9.73	86.8	8.11
9.83	87.3	7.90
100.1	88.2	7.49
10.25	89.4	7.00
10.41	90.2	6.67
10.61	91.2	6.35
10.72	91.8	6.16
10.82	92.2	6.01
10.97	93.0	5.77
11.03	93.3	5.69
11.27	94.5	5.35
11.42	95.1	5.17
11.50	95.5	5.07



b)

Because of $\ln \frac{R}{R'} = \gamma \ln 0.512$; $\gamma = \ln \frac{R}{R'} / \ln 0.512 = \ln \frac{5.07}{8.11} / \ln 0.512 = 0.702$

For working out $\Delta\gamma$ we know that:

$$R \pm \Delta R = 5.07 \pm 0.01 \text{ k}\Omega$$

$$R' \pm \Delta R' = 8.11 \pm 0.01 \text{ k}\Omega$$

$$\text{Transmittance, } t = 51.2 \%$$

Working out the error for two methods:

Method A

$$\gamma = \frac{\ln R/R'}{\ln t} ; \Delta\gamma = \frac{1}{\ln t} \left(\frac{\Delta R}{R} + \frac{\Delta R'}{R'} \right) = \frac{1}{\ln 0.512} \left(\frac{0.01}{5.07} + \frac{0.01}{8.11} \right) = 0.00479 ; \Delta\gamma = 0.005$$

Method B

Higher value of γ : $\gamma_{\max} = \ln \frac{R - \Delta R}{R' + \Delta R'} / \ln \gamma = \ln \frac{5.07 - 0.01}{8.11 + 0.01} / \ln 0.512 = 0.70654$

Smaller value of γ : $\gamma_{\min} = \ln \frac{R + \Delta R}{R' - \Delta R'} / \ln \gamma = \ln \frac{5.07 + 0.01}{8.11 - 0.01} / \ln 0.512 = 0.69696$

$$\Delta\gamma = \frac{\gamma_{\max} - \gamma_{\min}}{2} = \frac{0.70654 - 0.69696}{2} = 0.00479 ; \Delta\gamma = 0.005$$

$R = 5.07 \text{ k}\Omega$	$\gamma = 0.702$
$R' = 8.11 \text{ k}\Omega$	$\Delta\gamma = 0.005$

c)

We know that $R = c_3 e^{\frac{c_2\gamma}{\lambda_0 T}}$ (3)

then $\ln R = \ln c_3 + \frac{c_2\gamma}{\lambda_0 T}$

Because of $T = aR_B^{0.83}$ (6)

consequently $\ln R = \ln c_3 + \frac{c_2\gamma}{\lambda_0 a} R_B^{-0.83}$

$\ln R = \ln c_3 + \frac{c_2\gamma}{\lambda_0 a} R_B^{-0.83}$ Eq. (9)



d)

V/V	I/mA	R_B/Ω	T/K	$R_B^{-0.83}$ (S.I.)	$R/\text{k}\Omega$	$\ln R$
9.48 ± 0.01	85.5 ± 0.1	110.9 ± 0.2	1962 ± 18	$(2.008 \pm 0.004)10^{-2}$	8.77 ± 0.01	2.171 ± 0.001
9.73 ± 0.01	86.8 ± 0.1	112.1 ± 0.2	1980 ± 18	$(1.990 \pm 0.004)10^{-2}$	8.11 ± 0.01	2.093 ± 0.001
9.83 ± 0.01	87.3 ± 0.1	112.6 ± 0.2	1987 ± 18	$(1.983 \pm 0.004)10^{-2}$	7.90 ± 0.01	2.067 ± 0.001
10.01 ± 0.01	88.2 ± 0.1	113.5 ± 0.2	2000 ± 18	$(1.970 \pm 0.004)10^{-2}$	7.49 ± 0.01	2.014 ± 0.001
10.25 ± 0.01	89.4 ± 0.1	114.7 ± 0.2	2018 ± 18	$(1.952 \pm 0.003)10^{-2}$	7.00 ± 0.01	1.946 ± 0.001
10.41 ± 0.01	90.2 ± 0.1	115.4 ± 0.2	2028 ± 18	$(1.943 \pm 0.003)10^{-2}$	6.67 ± 0.01	1.894 ± 0.002
10.61 ± 0.01	91.2 ± 0.1	116.3 ± 0.2	2041 ± 18	$(1.930 \pm 0.003)10^{-2}$	6.35 ± 0.01	1.849 ± 0.002
10.72 ± 0.01	91.8 ± 0.1	116.8 ± 0.2	2049 ± 19	$(1.923 \pm 0.003)10^{-2}$	6.16 ± 0.01	1.818 ± 0.002
10.82 ± 0.01	92.2 ± 0.1	117.4 ± 0.2	2057 ± 19	$(1.915 \pm 0.003)10^{-2}$	6.01 ± 0.01	1.793 ± 0.002
10.97 ± 0.01	93.0 ± 0.1	118.0 ± 0.2	2066 ± 19	$(1.907 \pm 0.003)10^{-2}$	5.77 ± 0.01	1.753 ± 0.002
11.03 ± 0.01	93.3 ± 0.1	118.2 ± 0.2	2069 ± 19	$(1.904 \pm 0.003)10^{-2}$	5.69 ± 0.01	1.739 ± 0.002
11.27 ± 0.01	94.5 ± 0.1	119.3 ± 0.2	2085 ± 19	$(1.890 \pm 0.003)10^{-2}$	5.35 ± 0.01	1.677 ± 0.002
11.42 ± 0.01	95.1 ± 0.1	120.1 ± 0.2	2096 ± 19	$(1.880 \pm 0.003)10^{-2}$	5.15 ± 0.01	1.639 ± 0.002
11.50 ± 0.01	95.5 ± 0.1	120.4 ± 0.2	2101 ± 19	$(1.875 \pm 0.003)10^{-2}$	5.07 ± 0.01	1.623 ± 0.002
			unnecessary			

We work out the errors for all the first row, as example.

$$\text{Error for } R_B: \Delta R_B = R_B \sqrt{\left(\frac{\Delta V}{V}\right)^2 + \left(\frac{\Delta I}{I}\right)^2} = 110.9 \sqrt{\left(\frac{0.01}{9.48}\right)^2 + \left(\frac{0.1}{85.5}\right)^2} = 0.2 \Omega$$

$$\text{Error for } T: \Delta T = T \left(\frac{\Delta a}{a} + 0.83 \frac{\Delta R_B}{R_B} \right); \Delta T = 1962 \left(\frac{0.3}{39.4} + 0.83 \frac{0.2}{110.9} \right) = 18 \text{ K}$$

Error for $R_B^{-0.83}$:

$$x = R_B^{-0.83}; \ln x = -0.83 \ln R_B; \Delta x = x \cdot 0.83 \frac{\Delta R_B}{R_B}; \Delta(R_B^{-0.83}) = R_B^{-0.83} \frac{\Delta R_B}{R_B}$$

$$\Delta(R_B^{-0.83}) = 0.020077 \frac{0.2}{110.9} \approx 0.004 \times 10^{-2}$$

$$\text{Error for } \ln R: \Delta \ln R = \frac{\Delta R}{R}; \Delta \ln R = \frac{0.01}{8.77} = 0.001$$

e)

We plot $\ln R$ versus $R_B^{-0.83}$.



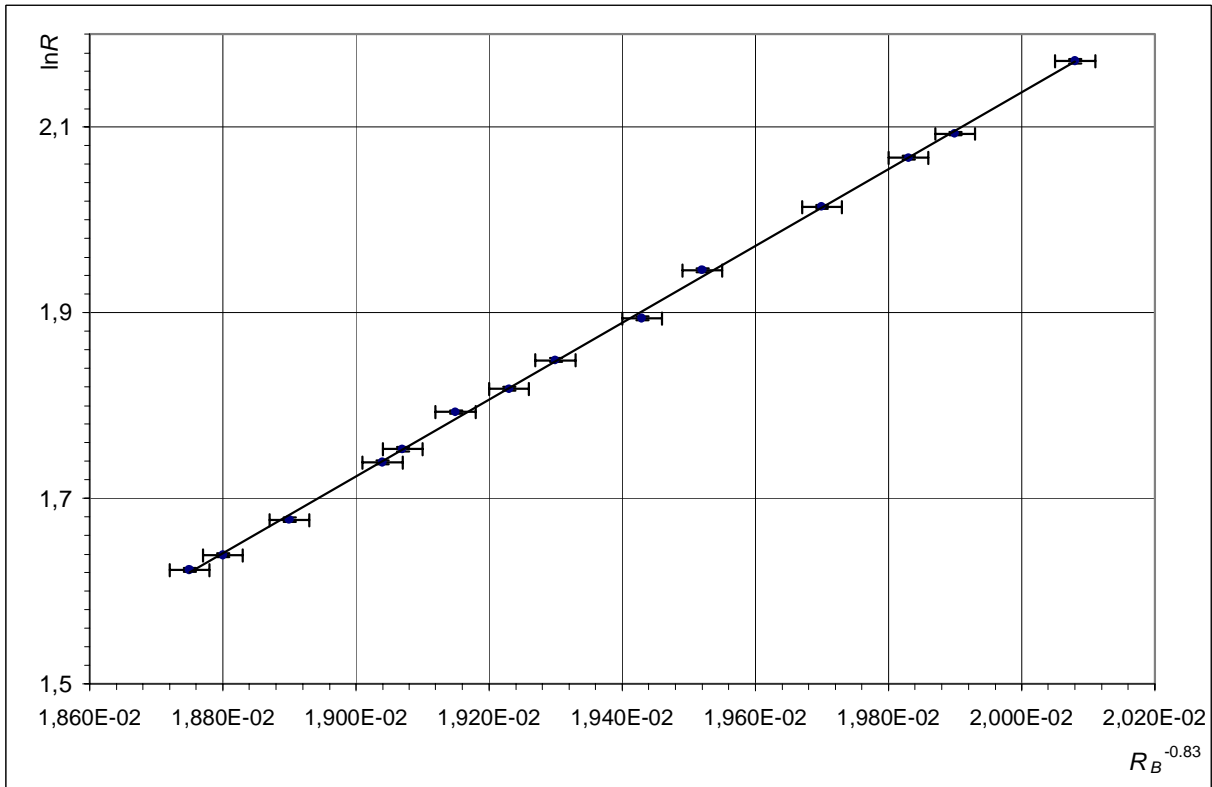

By the least squares

$$\text{Slope} = m = 414,6717$$

$$\sum (R_B^{-0.83})^2 = 5.23559 \times 10^{-3}$$

$$\sum (R_B^{-0.83}) = 0.27068$$

$$n = 14$$

$$\text{For axis } X: \sigma_{R_B^{-0.83}} = \sqrt{\frac{\sum \Delta(R_B^{-0.83})^2}{n}} = 0.003 \times 10^{-2}$$

$$\text{For axis } Y: \sigma_{\ln R} = \sqrt{\frac{\sum \Delta(\ln R)^2}{n}} = 0.002$$

$$\sigma = \sqrt{\sigma_{\ln R}^2 + m^2 \sigma_{R_B^{-0.83}}^2} = \sqrt{0.002^2 + 414.672^2 \cdot (0.003 \times 10^{-2})^2} = 0.0126$$

$$\Delta m = \sqrt{\frac{n \sigma^2}{n \sum (R_B^{-0.83})^2 - (\sum R_B^{-0.83})^2}} = \sqrt{\frac{14 \cdot 0,0126^2}{14 \cdot 5.23559 \times 10^{-3} - (0.27068)^2}} = 8.295$$

Because of

$$m = \frac{c_2 \gamma}{\lambda_0 a}$$

and

$$c_2 = \frac{hc}{k}$$

then

$$h = \frac{mk \lambda_0 a}{c \gamma}$$

$$h = \frac{414.67 \cdot 1.381 \times 10^{-23} \cdot 590 \times 10^{-9} \cdot 39.4}{2.998 \times 10^8 \cdot 0.702} = 6.33 \times 10^{-34}$$

$$\Delta h = h \sqrt{\left(\frac{\Delta m}{m}\right)^2 + \left(\frac{\Delta k}{k}\right)^2 + \left(\frac{\Delta \lambda_0}{\lambda_0}\right)^2 + \left(\frac{\Delta a}{a}\right)^2 + \left(\frac{\Delta \gamma}{\gamma}\right)^2}$$

$$\Delta h = 6.34 \times 10^{-34} \sqrt{\left(\frac{8.3}{415}\right)^2 + 0 + \left(\frac{28}{590}\right)^2 + \left(\frac{0.3}{39.4}\right)^2 + 0 + \left(\frac{0.01}{0.70}\right)^2} = 0.34 \times 10^{-34}$$

$h = 6.3 \times 10^{-34} \text{ J} \cdot \text{s}$	$\Delta h = 0.3 \times 10^{-34} \text{ J} \cdot \text{s}$
--	---

Theory Question 1: Gravity in a Neutron Interferometer

Enter all your answers into the **Answer Script**.

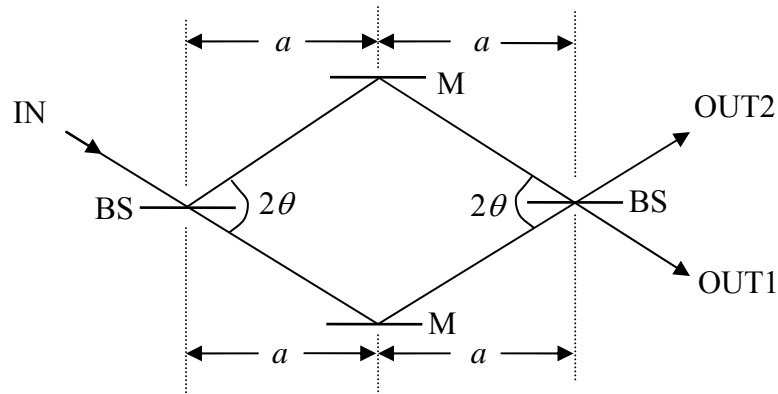

BS - Beam Splitters

M - Mirror

Figure 1a

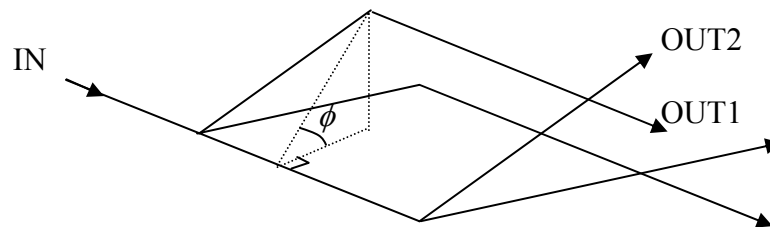

Figure 1b

Physical situation We consider the situation of the famous neutron-interferometer experiment by Collela, Overhauser and Werner, but idealize the set-up inasmuch as we shall assume perfect beam splitters and mirrors within the interferometer. The experiment studies the effect of the gravitational pull on the de Broglie waves of neutrons.

The symbolic representation of this interferometer in analogy to an optical interferometer is shown in Figure 1a. The neutrons enter the interferometer through the IN port and follow the two paths shown. The neutrons are detected at either one of the two output ports, OUT1 or OUT2. The two paths enclose a diamond-shaped area, which is typically a few cm^2 in size.

The neutron de Broglie waves (of typical wavelength of 10^{-10} m) interfere such that all neutrons emerge from the output port OUT1 if the interferometer plane is horizontal. But when the interferometer is tilted around the axis of the incoming neutron beam by angle ϕ (Figure 1b), one observes a ϕ dependent redistribution of the neutrons between the two output ports OUT1 and OUT2.

Geometry For $\phi = 0^\circ$ the interferometer plane is horizontal; for $\phi = 90^\circ$ the plane is vertical with the output ports above the tilt axis.

- 1.1** (1.0) How large is the diamond-shaped area A enclosed by the two paths of the interferometer?
- 1.2** (1.0) What is the height H of output port OUT1 above the horizontal plane of the tilt axis?

Express A and H in terms of a , θ , and ϕ .

Optical path length The optical path length N_{opt} (a number) is the ratio of the geometrical path length (a distance) and the wavelength λ . If λ changes along the path, N_{opt} is obtained by integrating λ^{-1} along the path.

- 1.3** (3.0) What is the difference ΔN_{opt} in the optical path lengths of the two paths when the interferometer has been tilted by angle ϕ ? Express your answer in terms of a , θ , and ϕ as well as the neutron mass M , the de Broglie wavelength λ_0 of the incoming neutrons, the gravitational acceleration g , and Planck's constant h .
- 1.4** (1.0) Introduce the volume parameter

$$V = \frac{h^2}{gM^2}$$

and express ΔN_{opt} solely in terms of A , V , λ_0 , and ϕ . State the value of V for $M = 1.675 \times 10^{-27}$ kg, $g = 9.800$ m s⁻², and $h = 6.626 \times 10^{-34}$ J s.

- 1.5** (2.0) How many cycles — from high intensity to low intensity and back to high intensity — are completed by output port OUT1 when ϕ is increased from $\phi = -90^\circ$ to $\phi = 90^\circ$?

Experimental data The interferometer of an actual experiment was characterized by $a = 3.600$ cm and $\theta = 22.10^\circ$, and 19.00 full cycles were observed.

- 1.6** (1.0) How large was λ_0 in this experiment?
- 1.7** (1.0) If one observed 30.00 full cycles in another experiment of the same kind that uses neutrons with $\lambda_0 = 0.2000$ nm, how large would be the area A ?

Hint: If $|\alpha x| \ll 1$, it is permissible to replace $(1+x)^\alpha$ by $1+\alpha x$.

Country Code	Student Code	Question Number
		1

Answer Script**Geometry**

1.1 The area is

$$A =$$

1.2 The height is

$$H =$$

**For
Examiners
Use
Only**

1.0

1.0

Country Code	Student Code	Question Number
		1

Optical path length

		For Examiners Use Only
1.3	In terms of a , θ , ϕ , M , λ_0 , g , and h : $\Delta N_{\text{opt}} =$	3.0
1.4	In terms of A , V , λ_0 , and ϕ : $\Delta N_{\text{opt}} =$ The numerical value of V is $V =$	0.8 0.2
1.5	The number of cycles is # of cycles =	2.0

Country Code	Student Code	Question Number
		1

Experimental data

1.6 The de Broglie wavelength was

$$\lambda_0 =$$

1.7 The area is

$$A =$$

**For
Examiners
Use
Only**

1.0

1.0

Theory Question 2: Watching a Rod in Motion

Enter all your answers into the **Answer Script**.

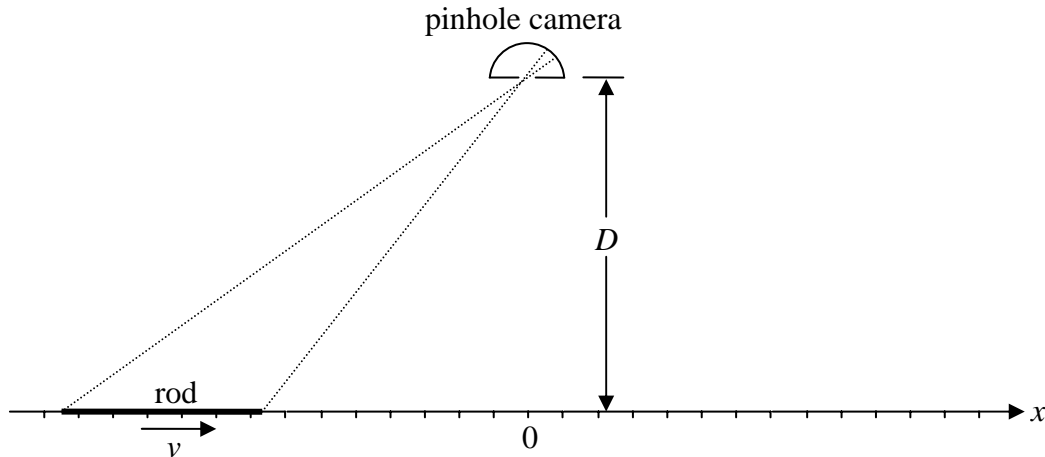

Physical situation A pinhole camera, with the pinhole at $x = 0$ and at distance D from the x axis, takes pictures of a rod, by opening the pinhole for a very short time. There are equidistant marks along the x axis by which the *apparent length* of the rod, as it is seen on the picture, can be determined from the pictures taken by the pinhole camera. On a picture of the rod *at rest*, its length is L . However, the rod is *not* at rest, but is moving with constant velocity v along the x axis.

Basic relations A picture taken by the pinhole camera shows a tiny segment of the rod at position \tilde{x} .

2.1 (0.6) What is the *actual position* x of this segment at the time when the picture is taken? State your answer in terms of \tilde{x} , D , L , v , and the speed of light $c = 3.00 \times 10^8 \text{ ms}^{-1}$. Employ the quantities

$$\beta = \frac{v}{c} \text{ and } \gamma = \frac{1}{\sqrt{1 - \beta^2}}$$

if they help to simplify your result.

2.2 (0.9) Find also the corresponding inverse relation, that is: express \tilde{x} in terms of x , D , L , v , and c .

Note: The *actual position* is the position in the frame in which the camera is at rest

Apparent length of the rod The pinhole camera takes a picture at the instant when the actual position of the center of the rod is at some point x_0 .

2.3 (1.5) In terms of the given variables, determine the apparent length of the rod on this picture.

2.4 (1.5) Check one of the boxes in the **Answer Script** to indicate how the apparent length changes with time.

Symmetric picture One pinhole-camera picture shows both ends of the rod at the same distance from the pinhole.

- 2.5** (0.8) Determine the apparent length of the rod on this picture.
- 2.6** (1.0) What is the actual position of the middle of the rod at the time when this picture is taken?
- 2.7** (1.2) Where does the picture show the image of the middle of the rod?

Very early and very late pictures The pinhole camera took one picture very early, when the rod was very far away and approaching, and takes another picture very late, when the rod is very far away and receding. On one of the pictures the apparent length is 1.00 m, on the other picture it is 3.00 m.

- 2.8** (0.5) Check the box in the **Answer Script** to indicate which length is seen on which picture.
- 2.9** (1.0) Determine the velocity v .
- 2.10** (0.6) Determine the length L of the rod at rest.
- 2.11** (0.4) Infer the apparent length on the symmetric picture.

Country Code	Student Code	Question Number
		2

Answer Script**Basic Relations**

2.1 x value for given \tilde{x} value:

$$x =$$

2.2 \tilde{x} value for given x value:

$$\tilde{x} =$$

**For
Examiners
Use
Only**

0.6

0.9

Apparent length of the rod

2.3 The apparent length is

$$\tilde{L}(x_0) =$$

2.4 Check one: The apparent length

- increases first, reaches a maximum value, then decreases.
- decreases first, reaches a minimum value, then increases.
- decreases all the time.
- increases all the time.

1.5

1.5

Country Code	Student Code	Question Number
		2

Symmetric picture

2.5 The apparent length is

$$\tilde{L} =$$

**For
Examiners
Use
Only**

0.8

2.6 The actual position of the middle of the rod is

$$x_0 =$$

1.0

2.7 The picture shows the middle of the rod at a distance

$$l =$$

1.2

from the image of the front end of the rod.

Country Code	Student Code	Question Number
		2

Very early and very late pictures

<p>2.8 Check one:</p> <p><input type="checkbox"/> The apparent length is 1 m on the early picture and 3 m on the late picture.</p> <p><input type="checkbox"/> The apparent length is 3 m on the early picture and 1 m on the late picture.</p> <p>2.9 The velocity is</p> <p>$v =$</p> <p>2.10 The rod has length</p> <p>$L =$</p> <p>at rest.</p> <p>2.11 The apparent length on the symmetric picture is</p> <p>$\tilde{L} =$</p>	<p>For Examiners Use Only</p> <p>0.5</p> <p>1.0</p> <p>0.6</p> <p>0.4</p>
---	--

Theory Question 3

This question consists of five independent parts. Each of them asks for an estimate of an order of magnitude only, not for a precise answer. Enter all your answers into the **Answer Script**.

Digital Camera Consider a digital camera with a square CCD chip with linear dimension $L = 35$ mm having $N_p = 5$ Mpix (1 Mpix = 10^6 pixels). The lens of this camera has a focal length of $f = 38$ mm. The well known sequence of numbers (2, 2.8, 4, 5.6, 8, 11, 16, 22) that appear on the lens refer to the so called F-number, which is denoted by $F\#$ and defined as the ratio of the focal length and the diameter D of the aperture of the lens, $F\# = f / D$.

- 3.1 (1.0) Find the best possible spatial resolution Δx_{\min} , at the chip, of the camera as limited by the lens. Express your result in terms of the wavelength λ and the F-number $F\#$ and give the numerical value for $\lambda = 500$ nm.
- 3.2 (0.5) Find the necessary number N of Mpix that the CCD chip should possess in order to match this optimal resolution.
- 3.3 (0.5) Sometimes, photographers try to use a camera at the smallest practical aperture. Suppose that we now have a camera of $N_0 = 16$ Mpix, with the chip size and focal length as given above. Which value is to be chosen for $F\#$ such that the image quality is not limited by the optics?
- 3.4 (0.5) Knowing that the human eye has an approximate angular resolution of $\phi = 2$ arcmin and that a typical photo printer will print a minimum of 300 dpi (dots per inch), at what minimal distance z should you hold the printed page from your eyes so that you do not see the individual dots?

Data 1 inch = 25.4 mm
1 arcmin = 2.91×10^{-4} rad

Hard-boiled egg An egg, taken directly from the fridge at temperature $T_0 = 4^\circ\text{C}$, is dropped into a pot with water that is kept boiling at temperature T_1 .

- 3.5** (0.5) How large is the amount of energy U that is needed to get the egg coagulated?
- 3.6** (0.5) How large is the heat flow J that is flowing into the egg?
- 3.7** (0.5) How large is the heat power P transferred to the egg?
- 3.8** (0.5) For how long do you need to cook the egg so that it is hard-boiled?

Hint You may use the simplified form of Fourier's Law $J = \kappa \Delta T / \Delta r$, where ΔT is the temperature difference associated with Δr , the typical length scale of the problem. The heat flow J is in units of W m^{-2} .

Data Mass density of the egg: $\mu = 10^3 \text{ kg m}^{-3}$
 Specific heat capacity of the egg: $C = 4.2 \text{ J K}^{-1} \text{ g}^{-1}$
 Radius of the egg: $R = 2.5 \text{ cm}$
 Coagulation temperature of albumen (egg protein): $T_c = 65^\circ\text{C}$
 Heat transport coefficient: $\kappa = 0.64 \text{ W K}^{-1} \text{ m}^{-1}$ (assumed to be the same for liquid and solid albumen)

Lightning An oversimplified model of lightning is presented. Lightning is caused by the build-up of electrostatic charge in clouds. As a consequence, the bottom of the cloud usually gets positively charged and the top gets negatively charged, and the ground below the cloud gets negatively charged. When the corresponding electric field exceeds the breakdown strength value of air, a disruptive discharge occurs: this is lightning.

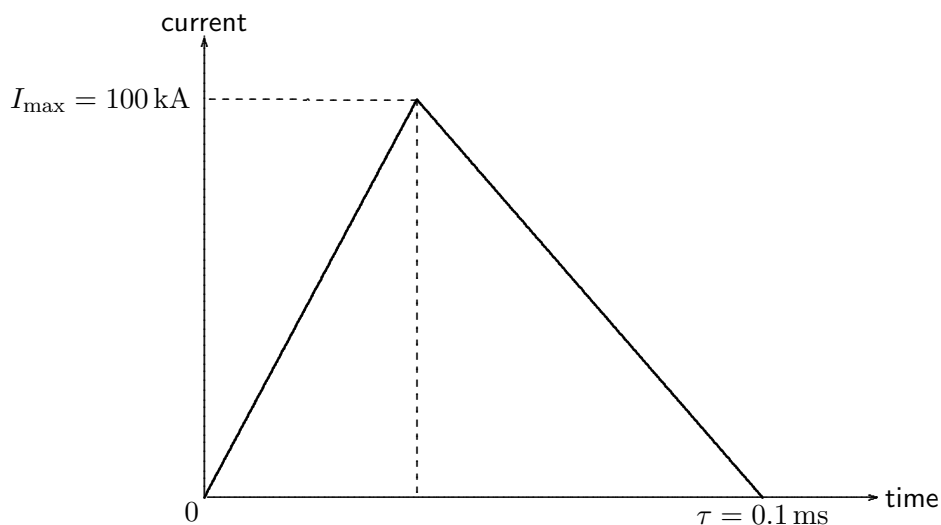

Idealized current pulse flowing between the cloud and the ground during lightning.

Answer the following questions with the aid of this simplified curve for the current as a function of time and these data:

Distance between the bottom of the cloud and the ground: $h = 1$ km;

Breakdown electric field of humid air: $E_0 = 300$ kV m⁻¹;

Total number of lightning striking Earth per year: 32×10^6 ;

Total human population: 6.5×10^9 people.

- 3.9** (0.5) What is the total charge Q released by lightning?
- 3.10** (0.5) What is the average current I flowing between the bottom of the cloud and the ground during lightning?
- 3.11** (1.0) Imagine that the energy of all storms of one year is collected and equally shared among all people. For how long could you continuously light up a 100 W light bulb for your share?

Capillary Vessels Let us regard blood as an incompressible viscous fluid with mass density μ similar to that of water and dynamic viscosity $\eta = 4.5$ g m⁻¹ s⁻¹. We model blood vessels as circular straight pipes with radius r and length L and describe the blood flow by Poiseuille's law,

$$\Delta p = RD,$$

the Fluid Dynamics analog of Ohm's law in Electricity. Here Δp is the pressure difference between the entrance and the exit of the blood vessel, $D = S\nu$ is the volume flow through the cross-sectional area S of the blood vessel and ν is the blood velocity. The hydraulic resistance R is given by

$$R = \frac{8\eta L}{\pi r^4}.$$

For the systemic blood circulation (the one flowing from the left ventricle to the right auricle of the heart), the blood flow is $D \approx 100$ cm³s⁻¹ for a man at rest. Answer the following questions under the assumption that all capillary vessels are connected in parallel and that each of them has radius $r = 4$ μ m and length $L = 1$ mm and operates under a pressure difference $\Delta p = 1$ kPa.

- 3.12** (1.0) How many capillary vessels are in the human body?
- 3.13** (0.5) How large is the velocity ν with which blood is flowing through a capillary vessel?

Skyscraper At the bottom of a 1000 m high skyscraper, the outside temperature is $T_{\text{bot}} = 30^\circ\text{C}$. The objective is to estimate the outside temperature T_{top} at the top. Consider a thin slab of air (ideal nitrogen gas with adiabatic coefficient $\gamma = 7/5$) rising slowly to height z where the pressure is lower, and assume that this slab expands adiabatically so that its temperature drops to the temperature of the surrounding air.

3.14 (0.5) How is the fractional change in temperature dT/T related to dp/p , the fractional change in pressure?

3.15 (0.5) Express the pressure difference dp in terms of dz , the change in height.

3.16 (1.0) What is the resulting temperature at the top of the building?

Data Boltzmann constant: $k = 1.38 \times 10^{-23} \text{ J K}^{-1}$
Mass of a nitrogen molecule: $m = 4.65 \times 10^{-26} \text{ kg}$
Gravitational acceleration: $g = 9.80 \text{ m s}^{-2}$

Country Code	Student Code	Question Number
		3

Answer Script**Digital Camera****For
Examiners
Use
Only****3.1** The best spatial resolution is(formula:) $\Delta x_{\min} =$ **0.7**

which gives

(numerical:) $\Delta x_{\min} =$ **0.3**for $\lambda = 500 \text{ nm}$.**3.2** The number of Mpix is $N =$ **0.5****3.3** The best F-number value is $F\# =$ **0.5****3.4** The minimal distance is $z =$ **0.5**

Country Code	Student Code	Question Number
		3

Hard-boiled egg

3.5 The required energy is

$$U =$$

**For
Examiners
Use
Only**

0.5

3.6 The heat flow is

$$J =$$

0.5

3.7 The heat power transferred is

$$P =$$

0.5

3.8 The time needed to hard-boil the egg is

$$\tau =$$

0.5

Country Code	Student Code	Question Number
		3

Lightning

<p>3.9 The total charge is</p> $Q =$	<p>For Examiners Use Only</p> <p>0.5</p>
<p>3.10 The average current is</p> $I =$	<p>0.5</p>
<p>3.11 The light bulb would burn for the duration</p> $t =$	<p>1.0</p>

Capillary Vessels

<p>3.12 There are</p> $N =$ <p>capillary vessels in a human body.</p>	<p>1.0</p>
<p>3.13 The blood flows with velocity</p> $v =$	<p>0.5</p>

Country Code	Student Code	Question Number
		3

Skyscraper

3.14 The fractional change in temperature is

$$\frac{dT}{T} =$$

3.15 The pressure difference is

$$dp =$$

3.16 The temperature at the top is

$$T_{\text{top}} =$$

**For
Examiners
Use
Only**

0.5

0.5

1.0



37th International Physics Olympiad

Singapore

8 - 17 July 2006

Experimental Competition

Wed 12 July 2006

List of apparatus and materials

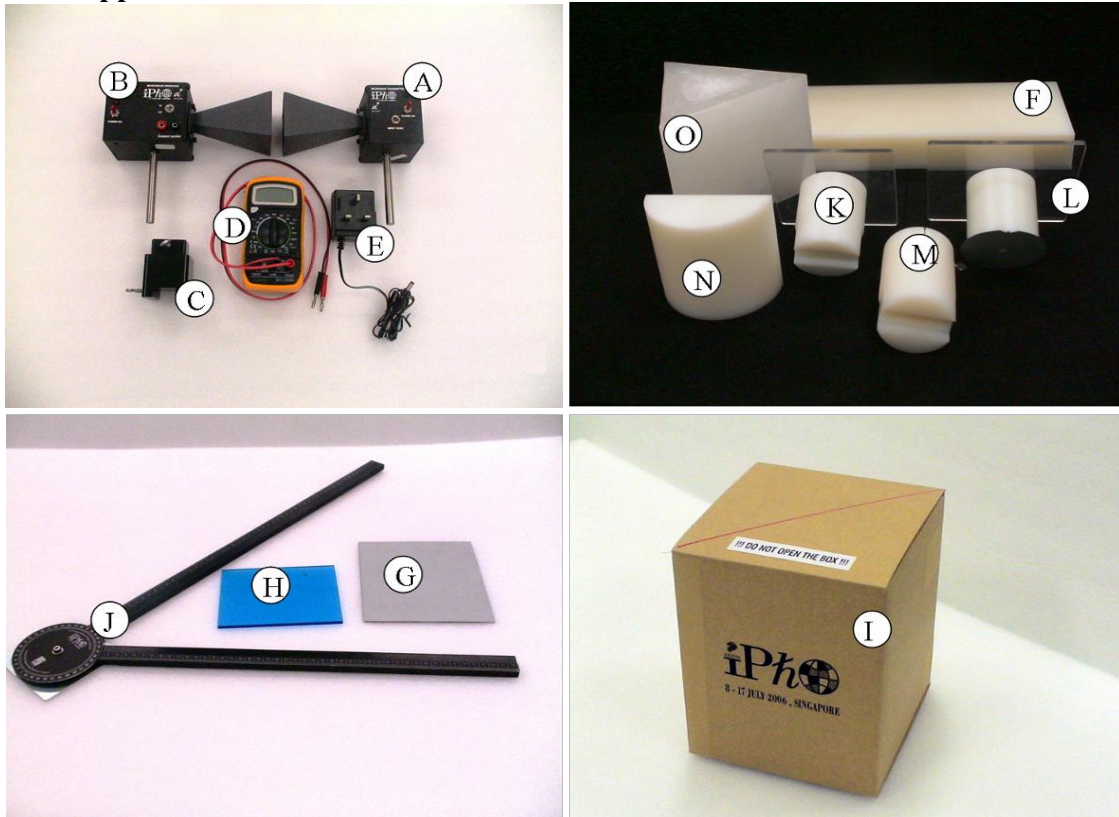

Label	Component	Quantity	Label	Component	Quantity
Ⓐ	Microwave transmitter	1	Ⓘ	Lattice structure in a black box	1
Ⓑ	Microwave receiver	1	⓵	Goniometer	1
Ⓒ	Transmitter/receiver holder	2	Ⓚ	Prism holder	1
Ⓓ	Digital multimeter	1	Ⓛ	Rotating table	1
Ⓔ	DC power supply for transmitter	1	Ⓜ	Lens/reflector holder	1
Ⓕ	Slab as a “Thin film” sample	1	Ⓝ	Plano-cylindrical lens	1
Ⓖ	Reflector (silver metal sheet)	1	Ⓞ	Wax prism	2
Ⓗ	Beam splitter (blue Perspex)	1		Blu-Tack	1 pack
	Vernier caliper (provided separately)			30 cm ruler (provided separately)	

Caution:

- The output power of the microwave transmitter is well within standard safety levels. Nevertheless, one should never look directly into the microwave horn at close range when the transmitter is on.
- Do not open the box containing the lattice ①.
- The wax prisms ② are fragile (used in Part 3).

Note:

- ***It is important to note that the microwave receiver output (CURRENT) is proportional to the AMPLITUDE of the microwave.***
- *Always use LO gain setting of the microwave receiver.*
- *Do not change the range of the multimeter during the data collection.*
- *Place the unused components away from the experiment to minimize interference.*
- *Always use the component labels (A, B, C,...) to indicate the components in all your drawings.*



The digital multimeter should be used with the two leads connected as shown in the diagram. You should use the “2m” current setting in this experiment.

Part 1: Michelson interferometer

1.1. Introduction

In a Michelson interferometer, a beam splitter sends an incoming electromagnetic (EM) wave along two separate paths, and then brings the constituent waves back together after reflection so that they superpose, forming an interference pattern. Figure 1.1 illustrates the setup for a Michelson interferometer. An incident wave travels from the transmitter to the receiver along two different paths. These two waves superpose and interfere at the receiver. The strength of signal at the receiver depends on the phase difference between the two waves, which can be varied by changing the optical path difference.

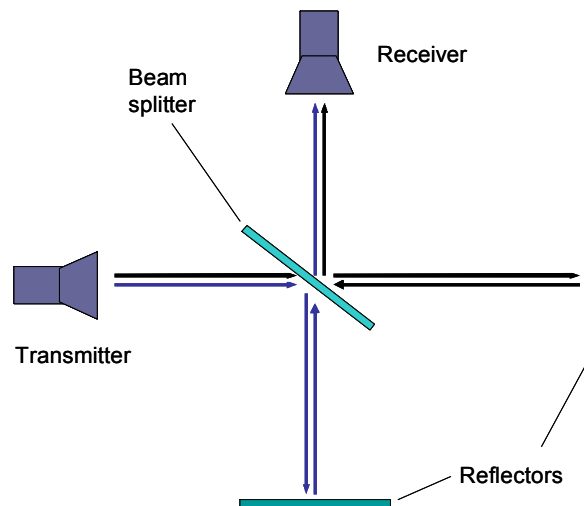

Figure 1.1: Schematic diagram of a Michelson interferometer.

1.2. List of components

- 1) Microwave transmitter (A) with holder (C)
- 2) Microwave receiver (B) with holder (C)
- 3) Goniometer (J)
- 4) 2 reflectors: reflector (G) with holder (M) and thin film (F) acting as a reflector.
- 5) Beam splitter (H) with rotating table (L) acting as a holder
- 6) Digital multimeter (D)

1.3. Task: Determination of wavelength of the microwave [2 marks]

Using only the experimental components listed in Section 1.2, set up a Michelson interferometer experiment to determine the wavelength λ of the microwave in air. Record your data and determine λ in such a way that the uncertainty is ≤ 0.02 cm.

Note that the “thin film” is partially transmissive, so make sure you do not stand or move behind it as this might affect your results.

Part 2: “Thin film” interference

2.1. Introduction

A beam of EM wave incident on a dielectric thin film splits into two beams, as shown in Figure 2.1. Beam A is reflected from the top surface of the film whereas beam B is reflected from the bottom surface of the film. The superposition of beams A and B results in the so called thin film interference.

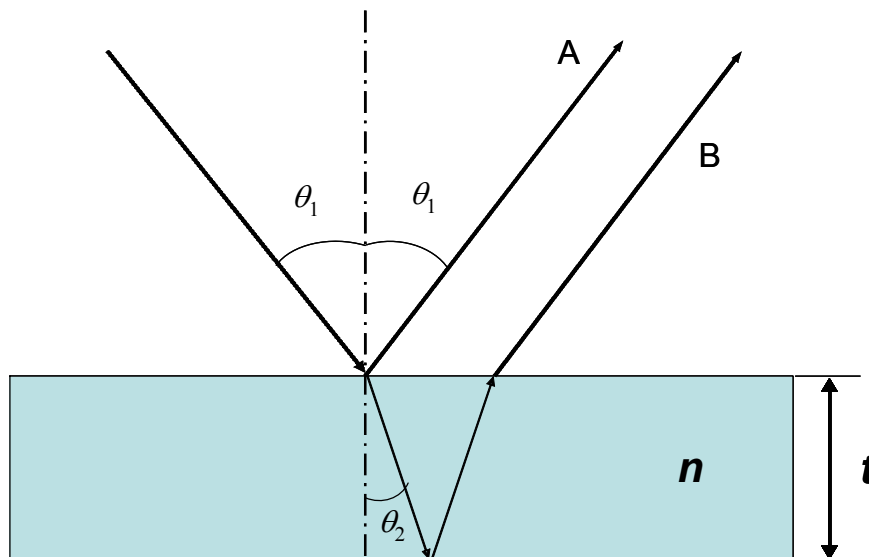

Figure 2.1: Schematic of thin film interference.

The difference in the optical path lengths of beam A and B leads to constructive or destructive interference. The resultant EM wave intensity I depends on the path difference of the two interfering beams which in turn depends on the angle of incidence, θ_1 , of the

incident beam, wavelength λ of the radiation, and the thickness t and refractive index n of the thin film. Thus, the refractive index n of the thin film can be determined from I - θ_1 plot, using values of t and λ .

2.2. List of components

- 1) Microwave transmitter (A) with holder (C)
- 2) Microwave receiver (B) with holder (C)
- 3) Plano-cylindrical lens (N) with holder (M)
- 4) Goniometer (J)
- 5) Rotating table (L)
- 6) Digital multimeter (D)
- 7) Polymer slab acting as a “thin film” sample (F)
- 8) Vernier caliper

2.3. Tasks: Determination of refractive index of polymer slab [6 marks]

- 1) Derive expressions for the conditions of constructive and destructive interferences in terms of θ_1 , t , λ and n .

[1 mark]
- 2) Using only the experimental components listed in Section 2.2, set up an experiment to measure the receiver output S as a function of the angle of incidence θ_1 in the range from 40° to 75° . Sketch your experimental setup, clearly showing the angles of incidence and reflection and the position of the film on the rotating table. Mark all components using the labels given on page 2. Tabulate your data. Plot the receiver output S versus the angle of incidence θ_1 . Determine accurately the angles corresponding to constructive and destructive interferences.

[3 marks]
- 3) Assuming that the refractive index of air is 1.00, determine the order of interference m and the refractive index of the polymer slab n . Write the values of m and n on the answer sheet.

[1.5 marks]

- 4) Carry out error analysis for your results and estimate the uncertainty of n . Write the value of the uncertainty Δn on the answer sheet.

[0.5 marks]

Note:

- *The lens should be placed in front of the microwave transmitter with the planar surface facing the transmitter to obtain a quasi-parallel microwave beam. The distance between the planar surface of the lens and the aperture of transmitter horn should be 3 cm.*
- *For best results, maximize the distance between the transmitter and receiver.*
- *Deviations of the microwave emitted by transmitter from a plane wave may cause extra peaks in the observed pattern. In the prescribed range from 40° to 75° , only one maximum and one minimum exist due to interference.*

Part 3: Frustrated Total Internal Reflection

3.1. Introduction

The phenomenon of total internal reflection (TIR) may occur when the plane wave travels from an optically dense medium to less dense medium. However, instead of TIR at the interface as predicted by geometrical optics, the incoming wave in reality penetrates into the less dense medium and travels for some distance parallel to the interface before being scattered back to the denser medium (see Figure 3.1). This effect can be described by a shift D of the reflected beam, known as the Goos-Hänchen shift.

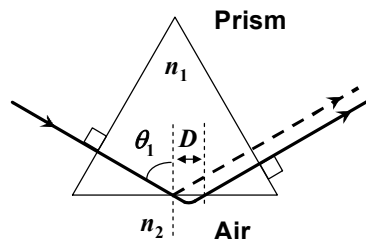

Figure 3.1: A sketch illustrating an EM wave undergoing total internal reflection in a prism. The shift D parallel to the surface in air represents the Goos-Hänchen shift

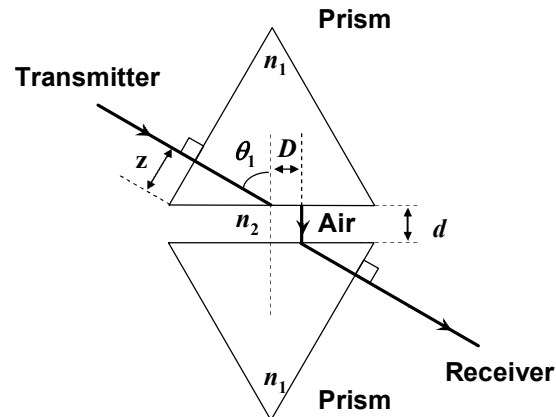

Figure 1.2: A sketch of the experimental setup showing the prisms and the air gap of distance d . The shift D parallel to the surface in air represents the Goos-Hänchen shift. z is the distance from the tip of the prism to the central axis of the transmitter.

If another medium of refractive index n_1 (i.e. made of the same material as the first medium) is placed at a small distance d to the first medium as shown in Figure 3.2, tunneling of the EM wave through the second medium occurs. This intriguing phenomenon is known as the *frustrated total internal reflection* (FTIR). The intensity of the transmitted wave, I_t , decreases exponentially with the distance d :

$$I_t = I_0 \exp(-2\gamma d) \quad (3.1)$$

where I_0 is the intensity of the incident wave and γ is:

$$\gamma = \frac{2\pi}{\lambda} \sqrt{\frac{n_1^2}{n_2^2} \sin^2 \theta_1 - 1} \quad (3.2)$$

where λ is the wavelength of EM wave in medium 2 and n_2 is the refractive index of medium 2 (assume that the refractive index of medium 2, air, is 1.00).

3.2. List of components

- 1) Microwave transmitter (A) with holder (C)

- 2) Microwave receiver (B) with holder (C)
- 3) Plano-cylindrical lens (N) with holder (M)
- 4) 2 equilateral wax prisms (O) with holder (K) and rotating table (L) acting as a holder
- 5) Digital multimeter (D)
- 6) Goniometer (J)
- 7) Ruler

3.3. Description of the Experiment

Using only the list of components described in Section 3.2, set up an experiment to investigate the variation of the intensity I_t as a function of the air gap separation d in FTIR. For consistent results, please take note of the following:

- Use one arm of the goniometer for this experiment.
- Choose the prism surfaces carefully so that they are parallel to each other.
- The distance from the centre of the curved surface of the lens should be 2 cm from the surface of the prism.
- Place the detector such that its horn is in contact with the face of the prism.
- For each value of d , adjust the position of the microwave receiver along the prism surface to obtain the maximum signal.
- Make sure that the digital multi-meter is on the 2mA range. Collect data starting from $d = 0.6$ cm. Discontinue the measurements when the reading of the multimeter falls below 0.20 mA.

3.4. Tasks: Determination of refractive index of prism material [6 marks]

Task 1

Sketch your final experimental setup and mark all components using the labels given at page 2. In your sketch, record the value of the distance z (see Figure 3.2), the distance from the tip of the prism to the central axis of the transmitter.

[1 Mark]

Task 2

Perform your experiment and tabulate your data. Perform this task twice.

[2.1 Marks]

Task 3

- (a) By plotting appropriate graphs, determine the refractive index, n_1 , of the prism with error analysis.
- (b) Write the refractive index n_1 , and its uncertainty Δn_1 , of the prism in the answer sheet provided.

[2.9 Marks]

Part 4: Microwave diffraction of a metal-rod lattice: Bragg reflection**4.1. Introduction****Bragg's Law**

The lattice structure of a real crystal can be examined using Bragg's Law,

$$2d \sin \theta = m\lambda \quad (4.1)$$

where d refers to the distance between a set of parallel crystal planes that “reflect” the X-ray; m is the order of diffraction and θ is the angle between the incident X-ray beam and the crystal planes. Bragg's law is also commonly known as Bragg's reflection or X-ray diffraction.

Metal-rod lattice

Because the wavelength of the X-ray is comparable to the lattice constant of the crystal, traditional Bragg's diffraction experiment is performed using X-ray. For microwave, however, diffraction occurs in lattice structures with much larger lattice constant, which can be measured easily with a ruler.

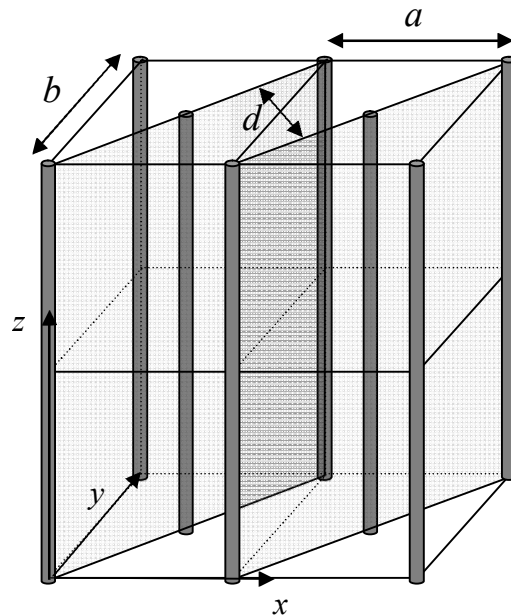

Figure 4.1: A metal-rod lattice of lattice constants a and b , and interplanar spacing d .

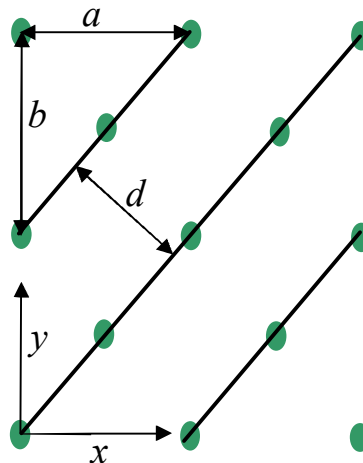

Figure 4.2: Top-view of the metal-rod lattice shown in Fig. 4.1 (not to scale). The lines denote diagonal planes of the lattice.

In this experiment, the Bragg law is used to measure the lattice constant of a lattice made of metal rods. An example of such metal-rod lattice is shown in Fig. 4.1, where the metal rods are shown as thick vertical lines. The lattice planes along the diagonal direction of the xy -plane are shown as shaded planes. Fig. 4.2 shows the top-view (looking down along the z -axis) of the metal-rod lattice, where the points represent the rods and the lines denote the diagonal lattice planes.

4.2. List of components

- 1) Microwave transmitter (A) with holder (C)
- 2) Microwave receiver (B) with holder (C)
- 3) Plano-cylindrical lens (N) with holder (M)
- 4) Sealed box containing a metal-rod lattice (I)
- 5) Rotating table (L)
- 6) Digital multimeter (D)
- 7) Goniometer (J)

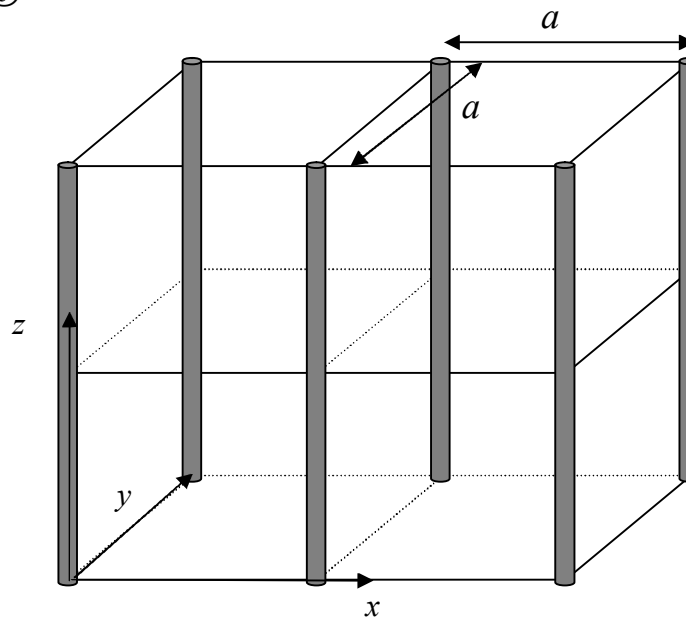

Figure 4.3: A simple square lattice.

In this experiment, you are given a simple square lattice made of metal rods, as illustrated in Fig. 4.3. The lattice is sealed in a box. You are asked to derive the lattice constant a of

the lattice from the experiment. DO NOT open the box. No marks will be given to the experimental results if the seal is found broken after the experiment.

4.3. Tasks: Determination of lattice constant of given simple square lattice [6 Marks]

Task 1

Draw a top-view diagram of the simple square lattice shown in Fig. 4.3. In the diagram, indicate the lattice constant a of the given lattice and the interplanar spacing d of the diagonal planes. With the help of this diagram, derive Bragg's Law.

[1 Mark]

Task 2

Using Bragg's law and the apparatus provided, design an experiment to perform Bragg diffraction experiment to determine the lattice constant a of the lattice.

- (a) Sketch the experimental set up. Mark all components using the labels in page 2 and indicate clearly the angle between the axis of the transmitter and lattice planes, θ , and the angle between the axis of the transmitter and the axis of the receiver, ζ . In your experiment, measure the diffraction on the diagonal planes the direction of which is indicated by the red line on the box.

[1.5 Marks]

- (b) Carry out the diffraction experiment for $20^\circ \leq \theta \leq 50^\circ$. In this range, you will only observe the first order diffraction. In the answer sheet, tabulate your results and record both the θ and ζ .

[1.4 Marks]

- (c) Plot the quantity proportional to the intensity of diffracted wave as a function of θ .

[1.3 Marks]

- (d) Determine the lattice constant a using the graph and estimate the experimental error.

[0.8 Marks]

Note:

- 1. For best results, the transmitter should remain fixed during the experiment. The separation between the transmitter and the lattice, as well as that between lattice and receiver should be about 50 cm.*
- 2. Use only the diagonal planes in this experiment. Your result will not be correct if you try to use any other planes.*
- 3. The face of the lattice box with the red diagonal line must be at the top.*
- 4. To determine the position of the diffraction peak with better accuracy, use a number of data points around the peak position.*

SOLUTIONS to Theory Question 1

Geometry Each side of the diamond has length $L = \frac{a}{\cos \theta}$ and the distance between parallel sides is $D = \frac{a}{\cos \theta} \sin(2\theta) = 2a \sin \theta$. The area is the product thereof, $A = LD$, giving

1.1

$$A = 2a^2 \tan \theta .$$

The height H by which a tilt of ϕ lifts out1 above in is $H = D \sin \phi$ or

1.2

$$H = 2a \sin \theta \sin \phi .$$

Optical path length Only the two parallel lines for in and out1 matter, each having length L . With the de Broglie wavelength λ_0 on the in side and λ_1 on the out1 side, we have

$$\Delta N_{\text{opt}} = \frac{L}{\lambda_0} - \frac{L}{\lambda_1} = \frac{a}{\lambda_0 \cos \theta} \left(1 - \frac{\lambda_0}{\lambda_1} \right) .$$

The momentum is h/λ_0 or h/λ_1 , respectively, and the statement of energy conservation reads

$$\frac{1}{2M} \left(\frac{h}{\lambda_0} \right)^2 = \frac{1}{2M} \left(\frac{h}{\lambda_1} \right)^2 + MgH ,$$

which implies

$$\frac{\lambda_0}{\lambda_1} = \sqrt{1 - 2 \frac{gM^2}{h^2} \lambda_0^2 H} .$$

Upon recognizing that $(gM^2/h^2)\lambda_0^2 H$ is of the order of 10^{-7} , this simplifies to

$$\frac{\lambda_0}{\lambda_1} = 1 - \frac{gM^2}{h^2} \lambda_0^2 H ,$$

and we get

$$\Delta N_{\text{opt}} = \frac{a}{\lambda_0 \cos \theta} \frac{gM^2}{h^2} \lambda_0^2 H$$

or

1.3

$$\Delta N_{\text{opt}} = 2 \frac{gM^2}{h^2} a^2 \lambda_0 \tan \theta \sin \phi .$$

A more compact way of writing this is

1.4

$$\Delta N_{\text{opt}} = \frac{\lambda_0 A}{V} \sin \phi ,$$

where

1.4

$$V = 0.1597 \times 10^{-13} \text{ m}^3 = 0.1597 \text{ nm cm}^2$$

is the numerical value for the volume parameter V .

There is constructive interference (high intensity in our1) when the optical path lengths of the two paths differ by an integer, $\Delta N_{\text{opt}} = 0, \pm 1, \pm 2, \dots$, and we have destructive interference (low intensity in our1) when they differ by an integer plus half, $\Delta N_{\text{opt}} = \pm \frac{1}{2}, \pm \frac{3}{2}, \pm \frac{5}{2}, \dots$. Changing ϕ from $\phi = -90^\circ$ to $\phi = 90^\circ$ gives

$$\Delta N_{\text{opt}} \Big|_{\phi=-90^\circ}^{\phi=90^\circ} = \frac{2\lambda_0 A}{V} ,$$

which tell us that

1.5

$$\# \text{ of cycles} = \frac{2\lambda_0 A}{V} .$$

Experimental data For $a = 3.6 \text{ cm}$ and $\theta = 22.1^\circ$ we have $A = 10.53 \text{ cm}^2$, so that

1.6

$$\lambda_0 = \frac{19 \times 0.1597}{2 \times 10.53} \text{ nm} = 0.1441 \text{ nm} .$$

And 30 full cycles for $\lambda_0 = 0.2 \text{ nm}$ correspond to an area

1.7

$$A = \frac{30 \times 0.1597}{2 \times 0.2} \text{ cm}^2 = 11.98 \text{ cm}^2 .$$

SOLUTIONS to Theory Question 2

Basic relations Position \tilde{x} shows up on the picture if light was emitted from there at an instant that is earlier than the instant of the picture taking by the light travel time T that is given by

$$T = \sqrt{D^2 + \tilde{x}^2}/c.$$

During the lapse of T the respective segment of the rod has moved the distance vT , so that its actual position x at the time of the picture taking is

2.1

$$x = \tilde{x} + \beta\sqrt{D^2 + \tilde{x}^2}.$$

Upon solving for \tilde{x} we find

2.2

$$\tilde{x} = \gamma^2 x - \beta\gamma\sqrt{D^2 + (\gamma x)^2}.$$

Apparent length of the rod Owing to the Lorentz contraction, the actual length of the moving rod is L/γ , so that the actual positions of the two ends of the rod are

$$x_{\pm} = x_0 \pm \frac{L}{2\gamma} \text{ for the } \left\{ \begin{array}{l} \text{front end} \\ \text{rear end} \end{array} \right\} \text{ of the rod.}$$

The picture taken by the pinhole camera shows the images of the rod ends at

$$\tilde{x}_{\pm} = \gamma\left(\gamma x_0 \pm \frac{L}{2}\right) - \beta\gamma\sqrt{D^2 + \left(\gamma x_0 \pm \frac{L}{2}\right)^2}.$$

The apparent length $\tilde{L}(x_0) = \tilde{x}_+ - \tilde{x}_-$ is therefore

2.3

$$\tilde{L}(x_0) = \gamma L + \beta\gamma\sqrt{D^2 + \left(\gamma x_0 - \frac{L}{2}\right)^2} - \beta\gamma\sqrt{D^2 + \left(\gamma x_0 + \frac{L}{2}\right)^2}.$$

Since the rod moves with the constant speed v , we have $\frac{dx_0}{dt} = v$ and therefore the question is whether $\tilde{L}(x_0)$ increases or decreases when x_0 increases. We sketch the two square root terms:

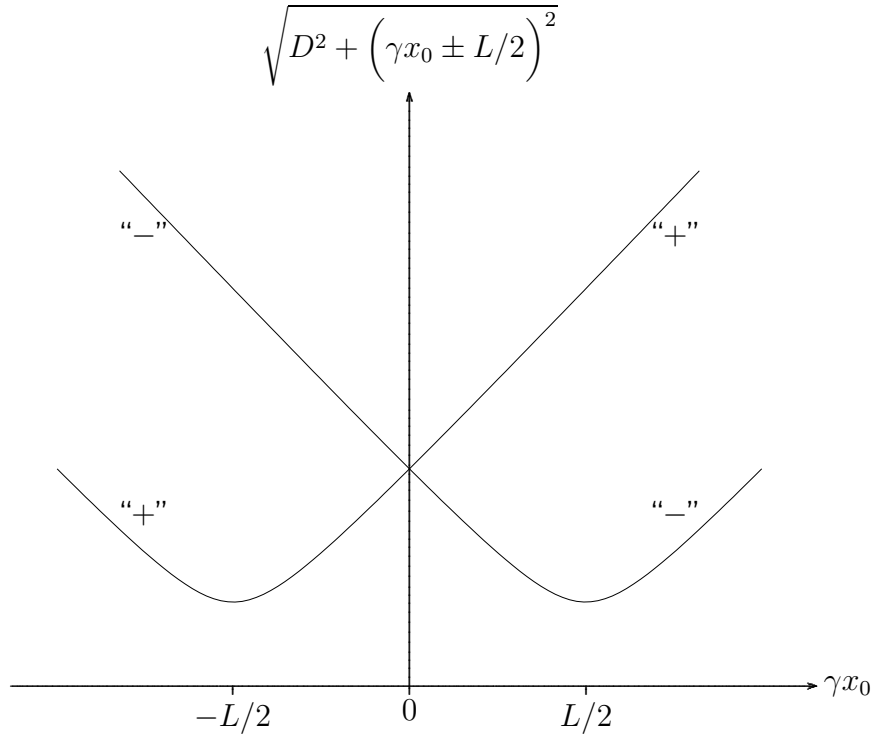

The difference of the square roots with “-” and “+” appears in the expression for $\tilde{L}(x_0)$, and this difference clearly decreases when x_0 increases.

2.4 The apparent length decreases all the time.

Symmetric picture For symmetry reasons, the apparent length on the symmetric picture is the actual length of the moving rod, because the light from the two ends was emitted simultaneously to reach the pinhole at the same time, that is:

2.5 $\tilde{L} = \frac{L}{\gamma}.$

The apparent endpoint positions are such that $\tilde{x}_- = -\tilde{x}_+$, or

$$0 = \tilde{x}_+ + \tilde{x}_- = 2\gamma^2 x_0 - \beta\gamma\sqrt{D^2 + \left(\gamma x_0 + \frac{L}{2}\right)^2} - \beta\gamma\sqrt{D^2 + \left(\gamma x_0 - \frac{L}{2}\right)^2}.$$

In conjunction with

$$\frac{L}{\gamma} = \tilde{x}_+ - \tilde{x}_- = \gamma L - \beta\gamma\sqrt{D^2 + \left(\gamma x_0 + \frac{L}{2}\right)^2} + \beta\gamma\sqrt{D^2 + \left(\gamma x_0 - \frac{L}{2}\right)^2}$$

this tells us that

$$\sqrt{D^2 + \left(\gamma x_0 \pm \frac{L}{2}\right)^2} = \frac{2\gamma^2 x_0 \pm (\gamma L - L/\gamma)}{2\beta\gamma} = \frac{\gamma x_0}{\beta} \pm \frac{\beta L}{2}.$$

As they should, both the version with the upper signs and the version with the lower signs give the same answer for x_0 , namely

2.6

$$x_0 = \beta\sqrt{D^2 + \left(\frac{L}{2\gamma}\right)^2}.$$

The image of the middle of the rod on the symmetric picture is, therefore, located at

$$\begin{aligned}\tilde{x}_0 &= \gamma^2 x_0 - \beta\gamma\sqrt{D^2 + (\gamma x_0)^2} \\ &= \beta\gamma\left(\sqrt{(\gamma D)^2 + \left(\frac{L}{2}\right)^2} - \sqrt{(\gamma D)^2 + \left(\frac{\beta L}{2}\right)^2}\right),\end{aligned}$$

which is at a distance $\ell = \tilde{x}_+ - \tilde{x}_0 = \frac{L}{2\gamma} - \tilde{x}_0$ from the image of the front end, that is

2.7

or

$$\begin{aligned}\ell &= \frac{L}{2\gamma} - \beta\gamma\sqrt{(\gamma D)^2 + \left(\frac{L}{2}\right)^2} + \beta\gamma\sqrt{(\gamma D)^2 + \left(\frac{\beta L}{2}\right)^2} \\ \ell &= \frac{L}{2\gamma} \left[1 - \frac{\frac{\beta L}{2}}{\sqrt{(\gamma D)^2 + \left(\frac{L}{2}\right)^2} + \sqrt{(\gamma D)^2 + \left(\frac{\beta L}{2}\right)^2}} \right].\end{aligned}$$

Very early and very late pictures At the very early time, we have a very large negative value for x_0 , so that the apparent length on the very early picture is

$$\tilde{L}_{\text{early}} = \tilde{L}(x_0 \rightarrow -\infty) = (1 + \beta)\gamma L = \sqrt{\frac{1 + \beta}{1 - \beta}} L.$$

Likewise, at the very late time, we have a very large positive value for x_0 , so that the apparent length on the very late picture is

$$\tilde{L}_{\text{late}} = \tilde{L}(x_0 \rightarrow \infty) = (1 - \beta)\gamma L = \sqrt{\frac{1 - \beta}{1 + \beta}} L.$$

It follows that $\tilde{L}_{\text{early}} > \tilde{L}_{\text{late}}$, that is:

2.8

The apparent length is 3 m on the early picture and 1 m on the late picture.

Further, we have

$$\beta = \frac{\tilde{L}_{\text{early}} - \tilde{L}_{\text{late}}}{\tilde{L}_{\text{early}} + \tilde{L}_{\text{late}}},$$

so that $\beta = \frac{1}{2}$ and the velocity is

2.9

$$v = \frac{c}{2}.$$

It follows that $\gamma = \frac{\tilde{L}_{\text{early}} + \tilde{L}_{\text{late}}}{2\sqrt{\tilde{L}_{\text{early}}\tilde{L}_{\text{late}}}} = \frac{2}{\sqrt{3}} = 1.1547$. Combined with

2.10

$$L = \sqrt{\tilde{L}_{\text{early}}\tilde{L}_{\text{late}}} = 1.73 \text{ m},$$

this gives the length on the symmetric picture as

2.11

$$\tilde{L} = \frac{2\tilde{L}_{\text{early}}\tilde{L}_{\text{late}}}{\tilde{L}_{\text{early}} + \tilde{L}_{\text{late}}} = 1.50 \text{ m}.$$

SOLUTIONS to Theory Question 3

Digital Camera Two factors limit the resolution of the camera as a photographic tool: the diffraction by the aperture and the pixel size. For diffraction, the inherent angular resolution θ_R is the ratio of the wavelength λ of the light and the aperture D of the camera,

$$\theta_R = 1.22 \frac{\lambda}{D},$$

where the standard factor of 1.22 reflects the circular shape of the aperture. When taking a picture, the object is generally sufficiently far away from the photographer for the image to form in the focal plane of the camera where the CCD chip should thus be placed. The Rayleigh diffraction criterion then states that two image points can be resolved if they are separated by more than

3.1

which gives

$$\Delta x = f\theta_R = 1.22\lambda F\sharp,$$

$$\Delta x = 1.22 \mu\text{m}$$

if we choose the largest possible aperture (or smallest value $F\sharp = 2$) and assume $\lambda = 500 \text{ nm}$ for the typical wavelength of daylight

The digital resolution is given by the distance ℓ between the center of two neighboring pixels. For our 5 Mpix camera this distance is roughly

$$\ell = \frac{L}{\sqrt{N_p}} = 15.65 \mu\text{m}.$$

Ideally we should match the optical and the digital resolution so that neither aspect is overspecified. Taking the given optical resolution in the expression for the digital resolution, we obtain

3.2

$$N = \left(\frac{L}{\Delta x}\right)^2 \approx 823 \text{ Mpix}.$$

Now looking for the unknown optimal aperture, we note that we should have $\ell \geq \Delta x$, that is: $F\sharp \leq F_0$ with

$$F_0 = \frac{L}{1.22\lambda\sqrt{N_0}} = 2\sqrt{\frac{N}{N_0}} = 14.34.$$

Since this $F\sharp$ value is not available, we choose the nearest value that has a higher optical resolution,

3.3

$$F_0 = 11 .$$

When looking at a picture at distance z from the eye, the (small) subtended angle between two neighboring dots is $\phi = \ell/z$ where, as above, ℓ is the distance between neighboring dots. Accordingly,

3.4

$$z = \frac{\ell}{\phi} = \frac{2.54 \times 10^{-2}/300 \text{ dpi}}{5.82 \times 10^{-4} \text{ rad}} = 14.55 \text{ cm} \approx 15 \text{ cm} .$$

Hard-boiled egg All of the egg has to reach coagulation temperature. This means that the increase in temperature is

$$\Delta T = T_c - T_0 = 65^\circ\text{C} - 4^\circ\text{C} = 61^\circ\text{C} .$$

Thus the minimum amount of energy that we need to get into the egg such that all of it has coagulated is given by $U = \mu VC\Delta T$ where $V = 4\pi R^3/3$ is the egg volume. We thus find

3.5

$$U = \mu \frac{4\pi R^3}{3} C(T_c - T_0) = 16768 \text{ J} .$$

The simplified equation for heat flow then allows us to calculate how much energy has flown into the egg through the surface per unit time. To get an approximate value for the time we assume that the center of the egg is at the initial temperature $T = 4^\circ\text{C}$. The typical length scale is $\Delta r = R$, and the temperature difference associated with it is $\Delta T = T_1 - T_0$ where $T_1 = 100^\circ\text{C}$ (boiling water). We thus get

3.6

$$J = \kappa(T_1 - T_0)/R = 2458 \text{ W m}^{-2} .$$

Heat is transferred from the boiling water to the egg through the surface of the egg. This gives

3.7

$$P = 4\pi R^2 J = 4\pi\kappa R(T_1 - T_0) \approx 19.3 \text{ W}$$

for the amount of energy transferred to the egg per unit time. From this we get an estimate for the time τ required for the necessary amount of heat to flow into the egg all the way to the center:

3.8

$$\tau = \frac{U}{P} = \frac{\mu C R^2}{3\kappa} \frac{T_c - T_0}{T_1 - T_0} = \frac{16768}{19.3} = 869 \text{ s} \approx 14.5 \text{ min.}$$

Lightning The total charge Q is just the area under the curve of the figure. Because of the triangular shape, we immediately get

3.9

$$Q = \frac{I_0 \tau}{2} = 5 \text{ C.}$$

The average current is

3.10

$$I = Q/\tau = \frac{I_0}{2} = 50 \text{ kA,}$$

simply half the maximal value.

Since the bottom of the cloud gets negatively charged and the ground positively charged, the situation is essentially that of a giant parallel-plate capacitor. The amount of energy stored just before lightning occurs is $QE_0h/2$ where E_0h is the voltage difference between the bottom of the cloud and the ground, and lightning releases this energy. Altogether we thus get for one lightning the energy $QE_0h/2 = 7.5 \times 10^8 \text{ J}$. It follows that you could light up the 100 W bulb for the duration

3.11

$$t = \frac{32 \times 10^6}{6.5 \times 10^9} \times \frac{7.5 \times 10^8 \text{ J}}{100 \text{ W}} \approx 10 \text{ h.}$$

Capillary Vessels Considering *all* capillaries, one has

$$R_{\text{all}} = \frac{\Delta p}{D} = 10^7 \text{ Pa m}^{-3} \text{ s.}$$

All capillaries are assumed to be connected in parallel. The analogy between Poiseuille's and Ohm's laws then gives the hydraulic resistance R of one capillary as

$$\frac{1}{R_{\text{all}}} = \frac{N}{R}.$$

We thus get

$$N = \frac{R}{R_{\text{all}}}$$

for the number of capillary vessels in the human body. Now calculate R using Poiseuille's law,

$$R = \frac{8\eta L}{\pi r^4} \approx 4.5 \times 10^{16} \text{ kg m}^{-4} \text{ s}^{-1},$$

and arrive at

$$\mathbf{3.12} \quad N \approx \frac{4.5 \times 10^{16}}{10^7} = 4.5 \times 10^9.$$

The volume flow is $D = S_{\text{all}}v$ where $S_{\text{all}} = N\pi r^2$ is the *total* cross-sectional area associated with all capillary vessels. We then get

$$\mathbf{3.13} \quad v = \frac{D}{N\pi r^2} = \frac{r^2 \Delta p}{8\eta L} = 0.44 \text{ mm s}^{-1},$$

where the second expression is found by alternatively considering one capillary vessel by itself.

Skyscraper When the slab is at height z above the ground, the air in the slab has pressure $p(z)$ and temperature $T(z)$ and the slab has volume $V(z) = Ah(z)$ where A is the cross-sectional area and $h(z)$ is the thickness of the slab. At any given height z , we combine the ideal gas law

$$pV = NkT \quad (N \text{ is the number of molecules in the slab})$$

with the adiabatic law

$$pV^\gamma = \text{const} \quad \text{or} \quad (pV)^\gamma \propto p^{\gamma-1}$$

to conclude that $p^{\gamma-1} \propto T^\gamma$. Upon differentiation this gives $(\gamma-1)\frac{dp}{p} = \gamma\frac{dT}{T}$, so that

3.14

$$\frac{dT}{T} = (1 - 1/\gamma) \frac{dp}{p}.$$

Since the slab is not accelerated, the weight must be balanced by the force that results from the difference in pressure at the top and bottom of the slab. Taking downward forces as positive, we have the net force

$$0 = Nmg + A[p(z+h) - p(z)] = \frac{pV}{kT}mg + \frac{V}{h} \frac{dp}{dz}h,$$

so that $\frac{dp}{dz} = -\frac{mg}{k} \frac{p}{T}$ or

3.15

$$dp = -\frac{mg}{k} \frac{p}{T} dz.$$

Taken together, the two expressions say that

$$dT = -(1 - 1/\gamma) \frac{mg}{k} dz$$

and therefore we have

$$T_{\text{top}} = T_{\text{bot}} - (1 - 1/\gamma) \frac{mgH}{k}$$

for a building of height H , which gives

3.16

$$T_{\text{top}} = 20.6^\circ\text{C}$$

for $H = 1$ km and $T_{\text{bot}} = 30^\circ\text{C}$.



**The 37th International Physics Olympiad
Singapore**

Experimental Competition

Wednesday, 12 July, 2006

Sample Solution

Part 1

a. A sketch of the experimental setup (not required)

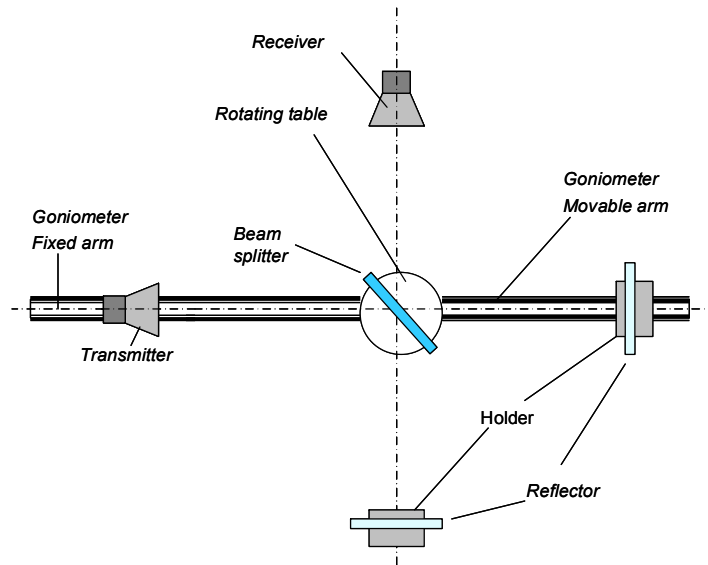

b. Data sheet (not required)

Position (cm)	Meter reading (mA)	Position (cm)	Meter reading (mA)	Position (cm)	Meter reading (mA)	Position (cm)	Meter reading (mA)
104.0	0.609	100.9	1.016	96.0	0.514	91.0	0.925
103.9	0.817	100.85	1.060	95.8	0.098	90.9	1.094
103.8	0.933	100.8	1.090	95.6	0.192	90.8	1.245
103.7	1.016	100.7	0.994	95.4	0.669	90.7	1.291
103.6	1.030	100.6	0.940	95.3	0.870	90.6	1.253
103.5	0.977	100.4	0.673	95.2	1.009	90.4	0.978
103.4	0.890	100.2	0.249	95.1	1.119	90.2	0.462
103.3	0.738	100.0	0.074	95.0	1.138	90.0	0.045
103.2	0.548	99.8	0.457	94.9	1.080	89.8	0.278
103.1	0.310	99.6	0.883	94.7	0.781	89.6	0.809
103.0	0.145	99.4	1.095	94.5	0.403	89.5	1.031
102.9	0.076	99.3	1.111	94.3	0.044	89.4	1.235
102.8	0.179	99.2	1.022	94.1	0.364	89.3	1.277
102.7	0.392	99.0	0.787	93.9	0.860	89.2	1.298
102.6	0.623	98.8	0.359	93.7	1.103	89.1	1.252
102.5	0.786	98.6	0.079	93.6	1.160	89.0	1.133
102.4	0.918	98.4	0.414	93.5	1.159	88.8	0.684
102.3	0.988	98.2	0.864	93.4	1.083	88.6	0.123
102.2	1.026	98.0	1.128	93.2	0.753	88.5	-0.020
102.1	1.006	97.9	1.183	93.0	0.331	88.4	0.123
102.0	0.945	97.8	1.132	92.8	0.073	88.2	0.679
101.9	0.747	97.7	1.015	92.6	0.515	88.0	1.116
101.8	0.597	97.5	0.713	92.4	0.968	87.9	1.265
101.7	0.363	97.2	0.090	92.2	1.217	87.8	1.339
101.6	0.161	97.0	0.342	92.15	1.234	87.7	1.313
101.5	0.055	96.8	0.714	92.1	1.230	87.6	1.190
101.4	0.139	96.6	1.007	92.0	1.165	87.4	0.867
101.3	0.357	96.5	1.087	91.8	0.871	87.2	0.316

101.2	0.589	96.4	1.070	91.6	0.353	87.1	0.034
101.1	0.781	96.3	1.018	91.4	0.018	87.0	-0.018
101.0	0.954	96.2	0.865	91.2	0.394	86.9	0.178
104.0	0.609	100.9	1.016	96.0	0.514	91.0	0.925
103.9	0.817	100.8	1.060	95.8	0.098	90.9	1.094
103.8	0.933	100.8	1.090	95.6	0.192	90.8	1.245
103.7	1.016	100.7	0.994	95.4	0.669	90.7	1.291
103.6	1.030	100.6	0.940	95.3	0.870	90.6	1.253
103.5	0.977	100.4	0.673	95.2	1.009	90.4	0.978
103.4	0.890	100.2	0.249	95.1	1.119	90.2	0.462
103.3	0.738	100.0	0.074	95.0	1.138	90.0	0.045
103.2	0.548	99.8	0.457	94.9	1.080	89.8	0.278
103.1	0.310	99.6	0.883	94.7	0.781	89.6	0.809
103.0	0.145	99.4	1.095	94.5	0.403	89.5	1.031
102.9	0.076	99.3	1.111	94.3	0.044	89.4	1.235
102.8	0.179	99.2	1.022	94.1	0.364	89.3	1.277
102.7	0.392	99.0	0.787	93.9	0.860	89.2	1.298
102.6	0.623	98.8	0.359	93.7	1.103	89.1	1.252
102.5	0.786	98.6	0.079	93.6	1.160	89.0	1.133
102.4	0.918	98.4	0.414	93.5	1.159	88.8	0.684
102.3	0.988	98.2	0.864	93.4	1.083	88.6	0.123
102.2	1.026	98.0	1.128	93.2	0.753	88.5	-0.020
102.1	1.006	97.9	1.183	93.0	0.331	88.4	0.123
102.0	0.945	97.8	1.132	92.8	0.073	88.2	0.679
101.9	0.747	97.7	1.015	92.6	0.515	88.0	1.116
101.8	0.597	97.5	0.713	92.4	0.968	87.9	1.265
101.7	0.363	97.2	0.090	92.2	1.217	87.8	1.339
101.6	0.161	97.0	0.342	92.15	1.234	87.7	1.313
101.5	0.055	96.8	0.714	92.1	1.230	87.6	1.190
101.4	0.139	96.6	1.007	92.0	1.165	87.4	0.867
101.3	0.357	96.5	1.087	91.8	0.871	87.2	0.316
101.2	0.589	96.4	1.070	91.6	0.353	87.1	0.034
101.1	0.781	96.3	1.018	91.4	0.018	87.0	-0.018
101.0	0.954	96.2	0.865	91.2	0.394	86.9	0.178

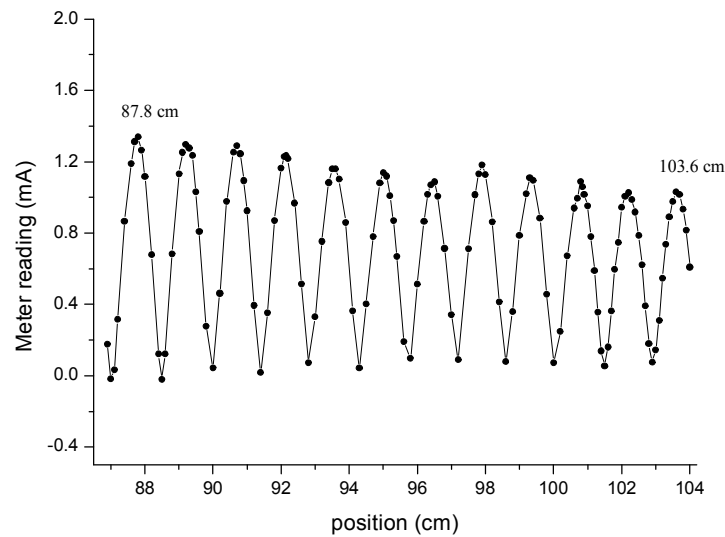

From the graph (not required) or otherwise, the positions of the first maximum point and 12th maximum point are measured at 87.8 cm and 103.6 cm.

The wavelength is calculated by

$$\frac{\lambda}{2} = \frac{103.6 - 87.8}{11} \text{ cm}$$

1.8 marks

Thus, $\lambda = 2.87 \text{ cm}$.

Error analysis

$$\lambda = \frac{2}{11} d, \quad \Delta d = 0.05 \times 2 \text{ cm} = 0.1 \text{ cm.}$$

$$|\Delta \lambda| = \left| \frac{2}{11} \Delta d \right| = \frac{2}{11} \times 0.10 = 0.018 \text{ cm} < 0.02 \text{ cm}$$

0.2 marks

Part 2

(a) Deduction of interference conditions

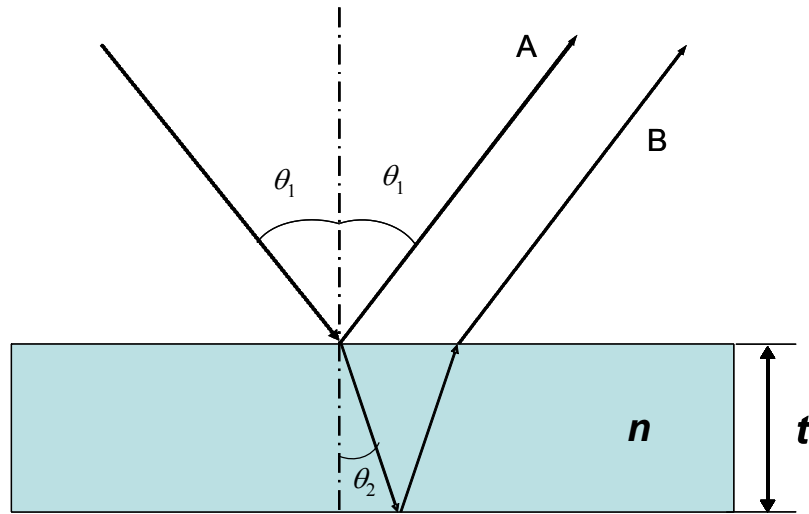

Assume that the thickness of the film is t and refractive index n . Let θ_1 be the incident angle and θ_2 the refracted angle. The difference of the optical paths ΔL is:

$$\Delta L = 2(nt / \cos \theta_2 - t \tan \theta_2 \sin \theta_1)$$

Law of refraction:

$$\sin \theta_1 = n \sin \theta_2$$

Thus

$$\Delta L = 2t\sqrt{n^2 - \sin^2 \theta_1}$$

Considering the 180 deg (π) phase shift at the air- thin film interface for the reflected beam, we have interference conditions:

$$2t\sqrt{n^2 - \sin^2 \theta_{\min}} = m\lambda \quad (m = 1, 2, 3, \dots) \quad \text{for the destructive peak}$$

and $2t\sqrt{n^2 - \sin^2 \theta_{\max}} = (m \pm \frac{1}{2})\lambda$ for the constructive peak

1 mark

If thickness t and wave length λ are known, one can determine the refractive index of the thin film from $I - \theta_1$ spectrum (I is the intensity of the interfered beam).

(b) A sketch of the experimental setup

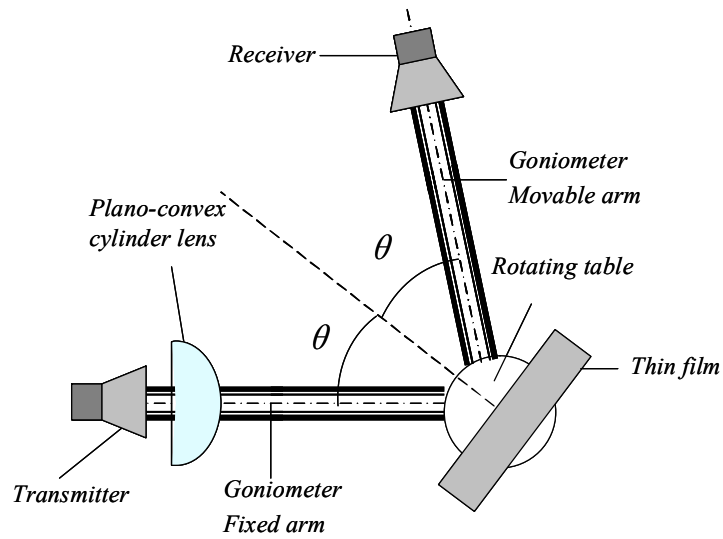

1 mark

Students should use the labeling on Page 2.

(c) Data Set

X: θ_1 / degree	Y: Meter reading S/mA
40.0	0.309
41.0	0.270
42.0	0.226
43.0	0.196
44.0	0.164
45.0	0.114
46.0	0.063
47.0	0.036
48.0	0.022
49.0	0.039
50.0	0.066
51.0	0.135
52.0	0.215
53.0	0.262
54.0	0.321
55.0	0.391
56.0	0.454
57.0	0.511

58.0	0.566
59.0	0.622
60.0	0.664
61.0	0.691
62.0	0.722
63.0	0.754
64.0	0.796
65.0	0.831
66.0	0.836
67.0	0.860
68.0	0.904
69.0	0.970
70.0	1.022
71.0	1.018
72.0	0.926
73.0	0.800
74.0	0.770
75.0	0.915

0.5 marks

Uncertainty: angle $\Delta\theta_1 = \pm 0.5^\circ$, current: ± 0.001 mA

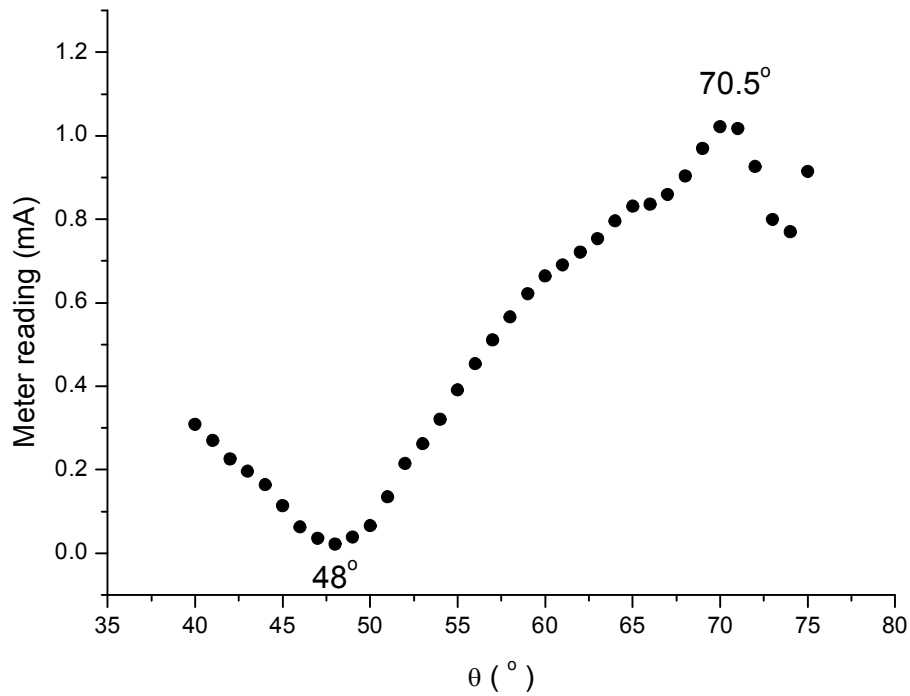

From the data, θ_{\min} and θ_{\max} can be found at 48° and 70.5° respectively.

0.9 marks

To calculate the refractive index, the following equations are used:

0.6 marks

$$2t\sqrt{n^2 - \sin^2 48^\circ} = m\lambda \quad (m = 1, 2, 3, \dots) \quad (1)$$

and

$$2t\sqrt{n^2 - \sin^2 70.5^\circ} = (m - \frac{1}{2})\lambda \quad (2)$$

In this experiment, $t = 5.28$ cm, $\lambda = 2.85$ cm (measured using other method).

Solving the simultaneous equations (1) and (2), we get

$$m = \frac{\sin^2 70.5^\circ - \sin^2 48^\circ}{(\frac{\lambda}{2t})^2} + 0.25$$

$$m = 4.83 \longrightarrow m = 5$$

1 mark

Substituting $m = 5$ in (1), we get $n = 1.54$

Substituting $m = 5$ in (2), we also get $n = 1.54$

0.5 marks

Error analysis:

$$n = \sqrt{\sin^2 \theta + (\frac{m\lambda}{2t})^2}$$

$$\Delta n = \frac{1}{\sqrt{\sin^2 \theta + (\frac{m\lambda}{2t})^2}} (\sin 2\theta \cdot \Delta \theta + \frac{m^2 \lambda}{2t^2} \Delta \lambda - \frac{m^2 \lambda^2}{2t^3} \Delta t)$$

$$= \frac{1}{n} (\sin 2\theta \cdot \Delta \theta + \frac{m^2 \lambda}{2t^2} \Delta \lambda - \frac{m^2 \lambda^2}{2t^3} \Delta t)$$

If we take $\Delta \theta = \pm 0.5^\circ = \pm 0.0087$ rad, $\Delta t = \pm 0.05$ cm, $\Delta \lambda = \pm 0.02$ cm, and $\theta = 48^\circ$

$$\Delta n = \frac{1}{1.54} (0.0087 \sin 96^\circ + \frac{5^2 \times 2.85}{2 \times 5.28^2} \times 0.01 + \frac{5^2 \times 2.85^2}{2 \times 5.28^3} \times 0.05) \approx 0.02$$

Thus,

$$n + \Delta n = 1.54 \pm 0.02$$

0.5 marks

Part 3

Sample Solution

Task 1

Sketch your final experimental setup and mark all components using the labels given at page 2. In your sketch, write down the distance z (see Figure 3.2), where z is the distance from the tip of the prism to the central axis of the transmitter.

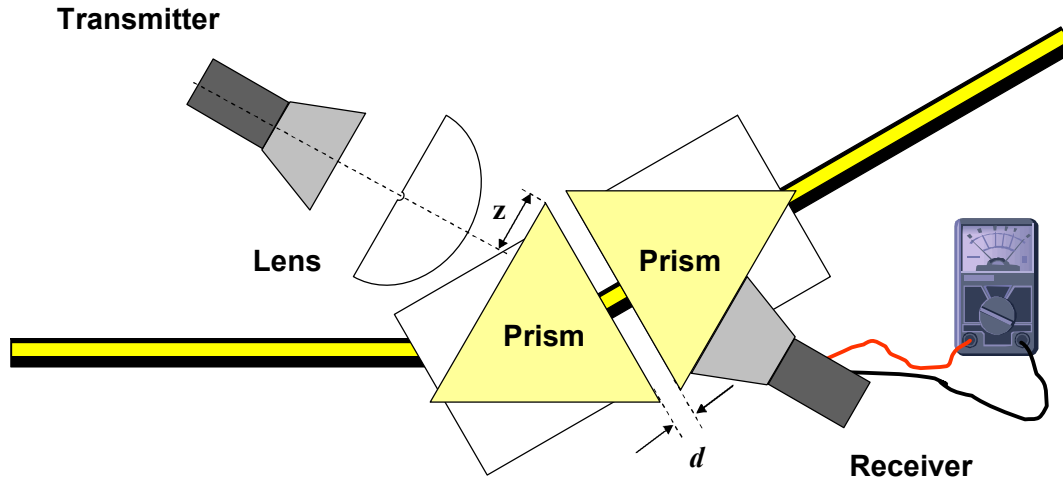

(Students should use labels on page 2.)

Task 2

Tabulate your data. Perform the experiment twice.

Data Set

X: $d(\text{cm})$	$\Delta X(\text{cm})$	Set 1 $S_1 (\text{mA})$	Set 2 $S_2(\text{mA})$	S_{average} (mA)	$\Delta S(\text{mA})^\#$	$I_t (\text{mA})^{2*}$	$\Delta(I_t)^\S$	Y: $\ln(I_t (\text{mA})^2)$	$\Delta Y^\&$
0.60	0.05	0.78	0.78	0.780	0.01	0.6080	0.016	-0.50	0.03
0.70	0.05	0.68	0.69	0.685	0.01	0.4690	0.014	-0.76	0.03
0.80	0.05	0.58	0.59	0.585	0.01	0.3420	0.012	-1.07	0.03
0.90	0.05	0.50	0.51	0.505	0.01	0.2550	0.010	-1.37	0.04
1.00	0.05	0.42	0.42	0.420	0.01	0.1760	0.008	-1.74	0.05
1.10	0.05	0.36	0.35	0.355	0.01	0.1260	0.007	-2.07	0.06
1.20	0.05	0.31	0.31	0.310	0.01	0.0961	0.006	-2.34	0.06
1.30	0.05	0.26	0.25	0.255	0.01	0.0650	0.005	-2.73	0.08
1.40	0.05	0.21	0.22	0.215	0.01	0.0462	0.004	-3.07	0.09

[#] $\Delta S = 0.01 \text{ mA}$ (for each set of current measurements)

^{*} S^2 proportional to the intensity, I_t

[§] $\Delta(S^2) = \Delta I_t = 2 S \times \Delta S$

[&] $\Delta Y = \Delta(\ln I_t) = \Delta(I_t)/I_t$

Task 3

By plotting appropriate graphs, determine the refractive index, n_1 , of the prism with error analysis. Write the refractive index n_1 , and its uncertainty Δn_1 , of the prism in the answer sheet provided.

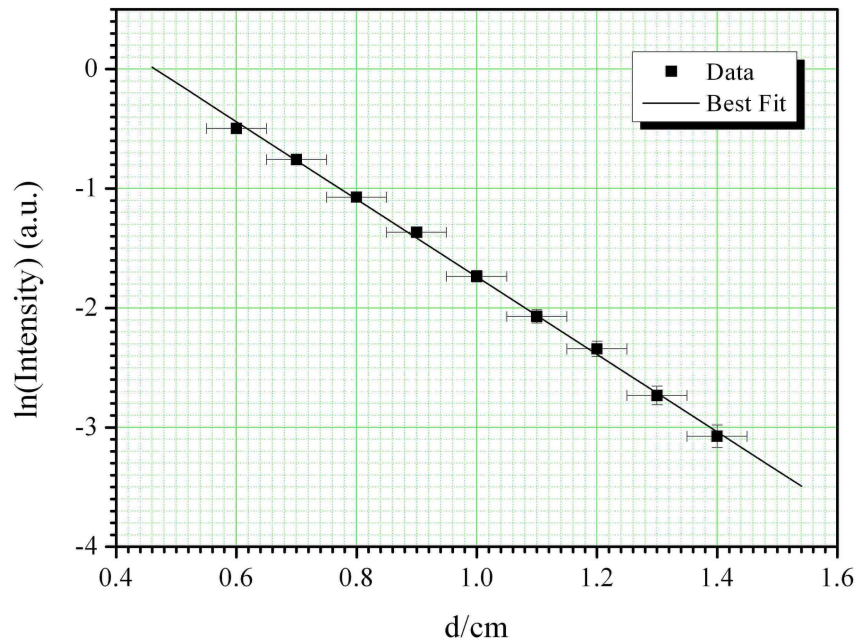

Least Square Fitting

X = d(cm)	$\Delta X(\text{cm})$	Y = $\ln(I_t)$	ΔY	ΔY^2	XY	X^2	Y^2
0.60	0.05	-0.50	0.03	0.001	-0.298	0.360	0.247
0.70	0.05	-0.76	0.03	0.001	-0.530	0.490	0.573
0.80	0.05	-1.07	0.03	0.001	-0.858	0.640	1.150
0.90	0.05	-1.37	0.04	0.002	-1.230	0.810	1.867
1.00	0.05	-1.74	0.05	0.002	-1.735	1.000	3.010
1.10	0.05	-2.07	0.06	0.003	-2.278	1.210	4.290
1.20	0.05	-2.34	0.06	0.004	-2.811	1.440	5.487
1.30	0.05	-2.73	0.08	0.006	-3.553	1.690	7.469
1.40	0.05	-3.07	0.09	0.009	-4.304	1.960	9.451
$\Sigma X =$		$\Sigma Y =$	$\Sigma \Delta Y =$	$\Sigma (\Delta Y)^2 =$	$\Sigma XY =$	$\Sigma X^2 =$	$\Sigma Y^2 =$
9.00		-15.648	0.469	0.029	-17.596	9.600	33.544

From $I_t = I_0 \exp(-2\gamma d)$, taking natural log on both sides, we obtain:

$$\ln(I_t) = -2\gamma d + \ln(I_0)$$

which is of the form $y = mx + c$.

To calculate the gradient, the following equation was used, where N is the number of data points:

$$m = \frac{N \sum (XY) - (\sum X)(\sum Y)}{N \sum X^2 - (\sum X)^2} = -3.247$$

To calculate the standard deviation σ_Y of the individual Y data values, the following equation was used:

$$\sigma_Y = \sqrt{\frac{\sum (\Delta Y)^2}{N - 2}} = 0.064$$

Hence the standard deviation in the slope can be calculated:

$$\sigma_m = \sigma_Y \sqrt{\frac{N}{N \sum X^2 - (\sum X)^2}} = 0.082$$

From the gradient:

$$\begin{aligned} 2\gamma &= 3.247 \pm 0.082 \\ &\approx 3.25 \pm 0.08 \end{aligned}$$

Using:

$$n_1 = \frac{\sqrt{k_2^2 + \gamma^2}}{k_2 \sin \theta_1}$$

where $\theta_1 = 60^\circ$, $k_2 = 2\pi/\lambda \approx 2.20$ (using the wavelength determined from earlier part (using $\lambda = (2.85 \pm 0.02)\text{cm}$), we obtain:

$\begin{aligned} n_1 \pm \Delta n_1 &= 1.434 \pm 0.016 \\ &\approx 1.43 \pm 0.02 \end{aligned}$

Error Analysis for refractive index of n_1

$$\Delta n_1 = \frac{d}{dk_2} \left[\frac{(k_2^2 + \gamma^2)^{1/2}}{k_2 \sin \theta_1} \right] \Delta k_2 + \frac{d}{d\gamma} \left[\frac{(k_2^2 + \gamma^2)^{1/2}}{k_2 \sin \theta_1} \right] \Delta \gamma$$

$$\Delta n_1 = \left[\frac{(k_2^2 + \gamma^2)^{-1/2}}{\sin \theta_1} - \frac{(k_2^2 + \gamma^2)^{1/2}}{k_2^2 \sin \theta_1} \right] \Delta k_2 + \left[\frac{\gamma (k_2^2 + \gamma^2)^{-1/2}}{k_2 \sin \theta_1} \right] \Delta \gamma$$

$$= 0.016$$

$$\approx 0.02$$

where:

$$\Delta k_2 = -\frac{2\pi}{\lambda^2} \Delta \lambda = -0.015$$

Note: Other methods of error analysis are also accepted.

Part 4

Task 1

Top-view of a simple square lattice.

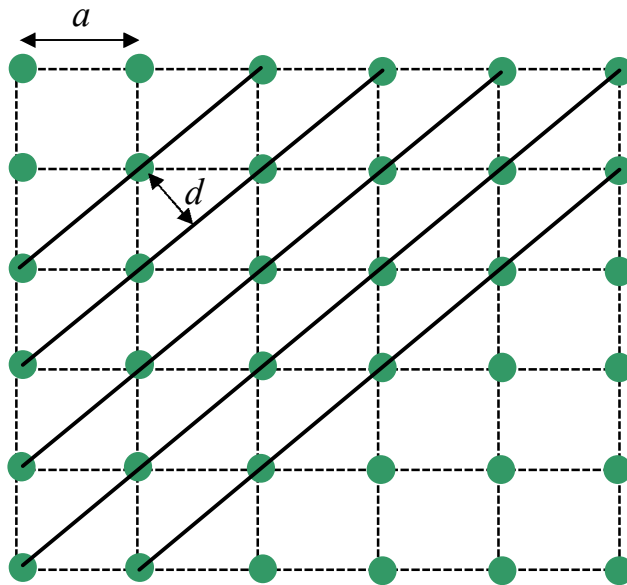

0.5 marks

Figure 4.1: Schematic diagram of a simple square lattice with lattice constant a and interplanar d of the diagonal planes indicated.

Deriving Bragg's Law

Conditions necessary for the observation of diffraction peaks:

1. The angle of incidence = angle of scattering.
2. The pathlength difference is equal to an integer number of wavelengths.

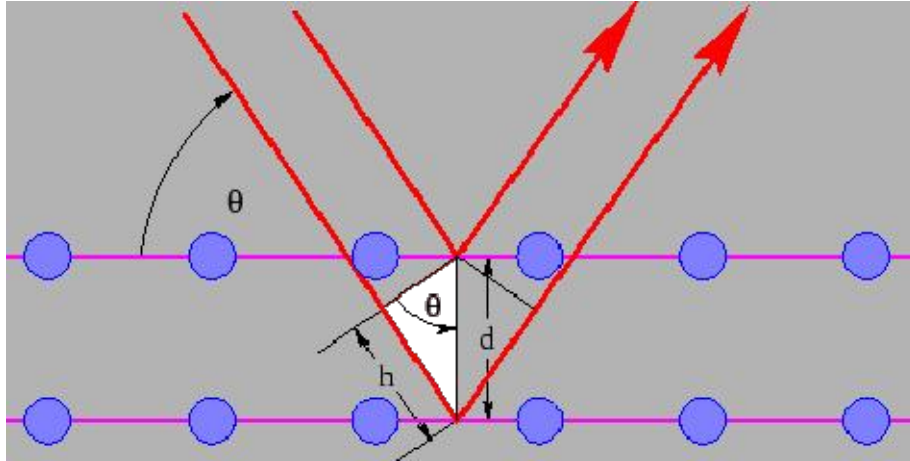

Figure 4.2: Schematic diagram for deriving Bragg's law.

$$h = d \sin \theta \quad (1).$$

The path length difference is given by,

$$2h = 2d \sin \theta \quad (2).$$

For diffraction to occur, the path difference must satisfy,

$$\boxed{2 d \sin \theta = m \lambda}, \quad m = 1, 2, 3... \quad (3).$$

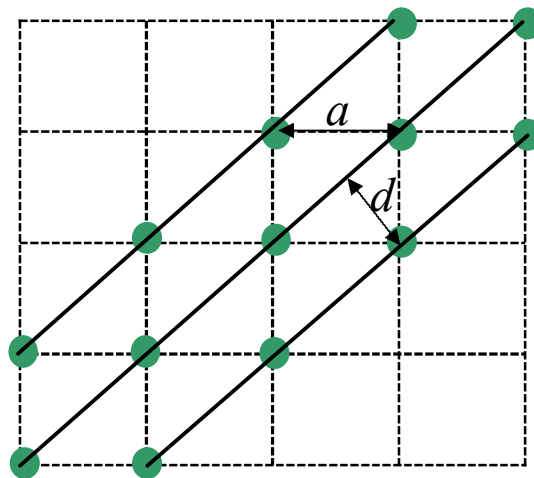

0.5 marks

Figure 4.3 Illustration of the lattice used in the experiment (this Figure is not required)

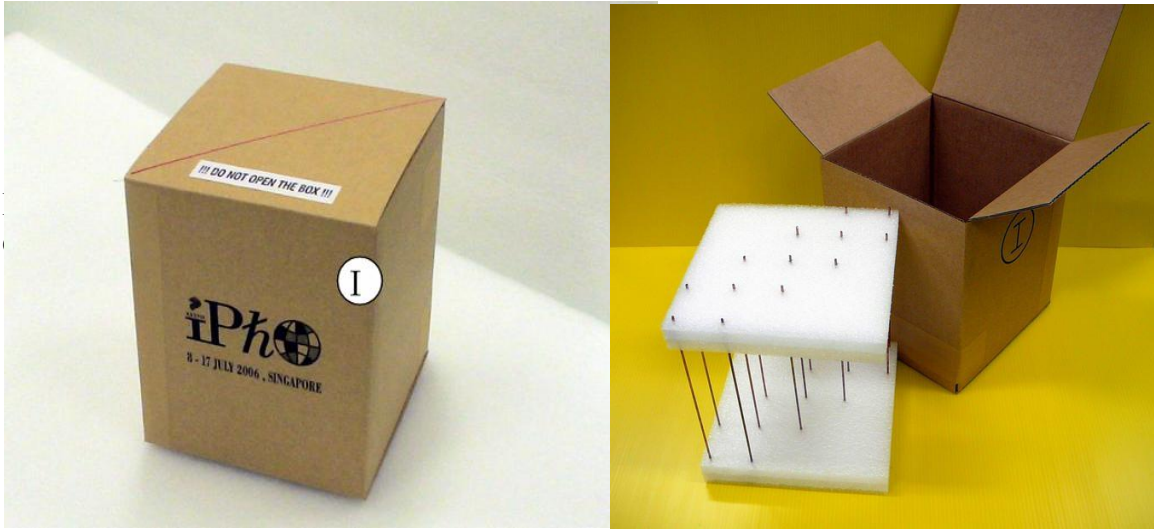
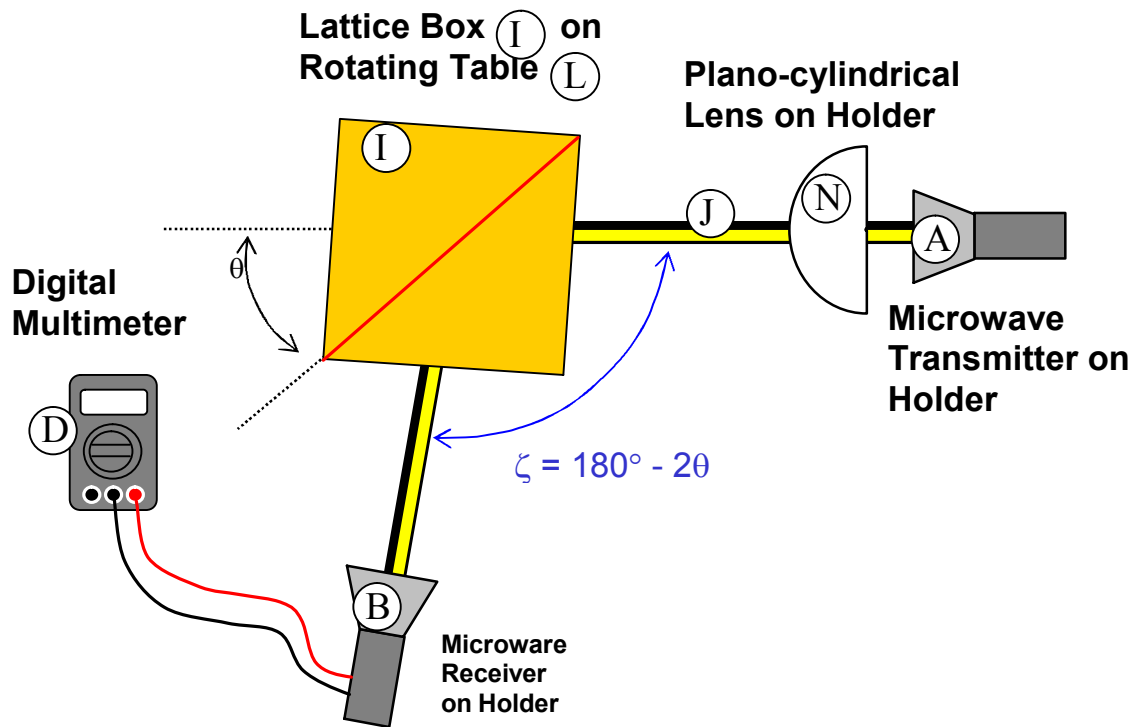

Fig. 4.4 The actual lattice used in the experiment (not required)

Task 2 (a)



1.5 marks

Fig. 4.5 Sketch of the experimental set up

Task 2(b) & 2(c)

Data Set

$\theta/^\circ$	$\zeta/^\circ$	Output current S (mA)	Intensity $I=S^2$ (mA) ²
20.0	140.0	0.023	0.000529
21.0	138.0	0.038	0.001444
22.0	136.0	0.070	0.0049
23.0	134.0	0.109	0.011881
24.0	132.0	0.163	0.026569
25.0	130.0	0.201	0.040401
26.0	128.0	0.233	0.054289
27.0	126.0	0.275	0.075625
28.0	124.0	0.320	0.1024
29.0	122.0	0.350	0.1225
30.0	120.0	0.353	0.124609
31.0	118.0	0.358	0.128164
32.0	116.0	0.354	0.125316
33.0	114.0	0.342	0.116964
34.0	112.0	0.321	0.103041
35.0	110.0	0.303	0.091809
36.0	108.0	0.280	0.0784
37.0	106.0	0.241	0.058081
38.0	104.0	0.200	0.04
39.0	102.0	0.183	0.033489
40.0	100.0	0.162	0.026244
41.0	98.0	0.139	0.019321
42.0	96.0	0.120	0.0144
43.0	94.0	0.109	0.011881
44.0	92.0	0.086	0.007396
45.0	90.0	0.066	0.004356
46.0	88.0	0.067	0.004489
47.0	86.0	0.066	0.004356
48.0	84.0	0.070	0.0049
49.0	82.0	0.084	0.007056
50.0	80.0	0.080	0.0064

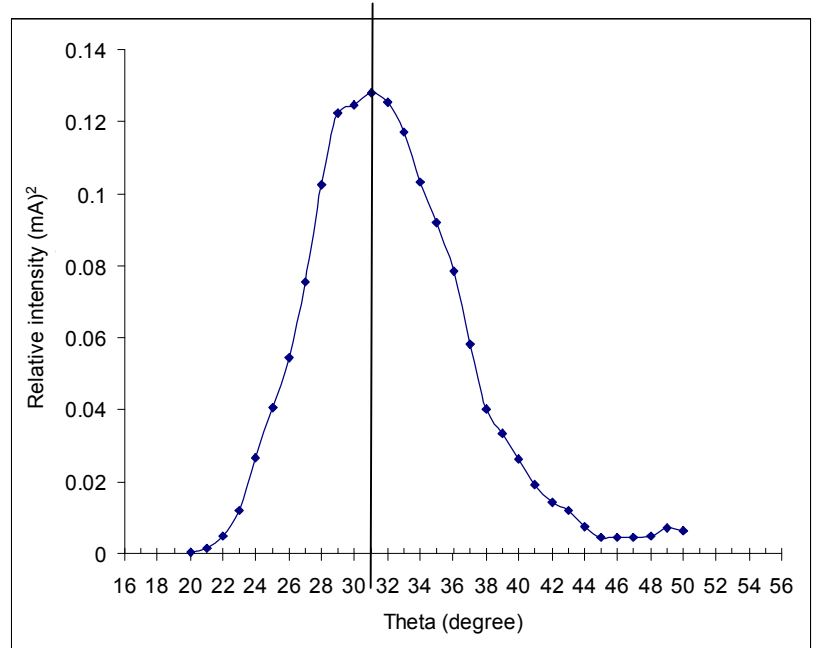

2.7 marks

Task 2(d)

From eq 3 and let $m = 1$,

$$2d \sin \theta_{\max} = \lambda \quad (4)$$

From Fig. 4.3,

$$a = \sqrt{2}d \quad (5)$$

Combine eqs (4) and (5), we obtain,

$$a = \frac{\lambda}{\sqrt{2} \sin \theta_{\max}}$$

From the symmetry of the data, the peak position is determined to be:

$$\theta_{\max} = 31^\circ \quad (\text{The theoretical value is } \theta_{\max} = 32^\circ)$$

$$a = \frac{\lambda}{\sqrt{2} \sin \theta_{\max}} = \frac{2.85\text{cm}}{\sqrt{2} \sin 31^\circ} = 3.913\text{cm}$$

(Actual value $a = 3.80 \text{ cm}$)

[The value 3.55 in the marking scheme is derived from:

$$a = \frac{\lambda}{\sqrt{2} \sin \theta_{\max}} = \frac{2.83\text{cm}}{\sqrt{2} \sin 34^\circ} = 3.58\text{cm}$$

where 2.83 cm and 34 deg are the min and max allowed values for wavelength and peak position.

Similarly:

$$\text{The value 4.10 is derived from: } a = \frac{\lambda}{\sqrt{2} \sin \theta_{\max}} = \frac{2.87\text{cm}}{\sqrt{2} \sin 30^\circ} = 4.06\text{cm}$$

$$\text{The value 3.55 is derived from: } a = \frac{\lambda}{\sqrt{2} \sin \theta_{\max}} = \frac{2.83\text{cm}}{\sqrt{2} \sin 34^\circ} = 3.58\text{cm}$$

$$\text{The value 3.40 is derived from: } a = \frac{\lambda}{\sqrt{2} \sin \theta_{\max}} = \frac{2.83\text{cm}}{\sqrt{2} \sin 35^\circ} = 3.49\text{cm}$$

$$\text{The value 4.20 is derived from: } a = \frac{\lambda}{\sqrt{2} \sin \theta_{\max}} = \frac{2.87\text{cm}}{\sqrt{2} \sin 29^\circ} = 4.18\text{cm}]$$

Error analysis:

Known uncertainties:

$$\Delta\lambda = 0.02 \text{ cm};$$

$$\Delta\theta = 0.5 \text{ deg} = 0.014 \text{ rad. (uncertainty in determining } \theta \text{ from graph).}$$

From: $a = \frac{\lambda}{\sqrt{2} \sin \theta_{\max}}$

$$\Delta a = \frac{\Delta \lambda}{\sqrt{2} \sin \theta_{\max}} - \frac{\lambda}{\sqrt{2} (\sin \theta_{\max})^2} \frac{d}{d\theta} (\sin \theta_{\max}) \Delta \theta$$

$$= a \left(\frac{\Delta \lambda}{\lambda} - \frac{1}{\sin \theta_{\max}} \frac{d}{d\theta} (\sin \theta_{\max}) \Delta \theta \right)$$

$$= a \left(\frac{\Delta \lambda}{\lambda} - \cot \theta_{\max} \Delta \theta \right)$$

$$= 3.80 \left(\frac{0.02}{2.85} - \cot(32^\circ) \times (-0.014) \right) \text{cm}$$

$$= 0.112 \text{cm} \approx 0.1$$

Hence:

$$a \pm \Delta a = 3.913 \pm 0.112 \\ \approx 3.9 \pm 0.1 \text{ cm}$$

0.8 marks



In this problem we deal with a simplified model of accelerometers designed to activate the safety air bags of automobiles during a collision. We would like to build an electromechanical system in such a way that when the acceleration exceeds a certain limit, one of the electrical parameters of the system such as the voltage at a certain point of the circuit will exceed a threshold and the air bag will be activated as a result.

Note: Ignore gravity in this problem.

- 1 Consider a capacitor with parallel plates as in Figure 1. The area of each plate in the capacitor is A and the distance between the two plates is d . The distance between the two plates is much smaller than the dimensions of the plates. One of these plates is in contact with a wall through a spring with a spring constant k , and the other plate is fixed. When the distance between the plates is d the spring is neither compressed nor stretched, in other words no force is exerted on the spring in this state. Assume that the permittivity of the air between the plates is that of free vacuum ϵ_0 . The capacitance corresponding to this distance between the plates of the capacitor is $C_0 = \epsilon_0 A/d$. We put charges $+Q$ and $-Q$ on the plates and let the system achieve mechanical equilibrium.

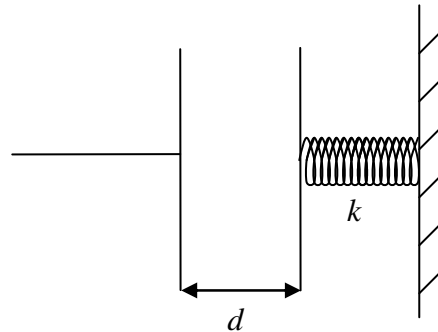

Figure 1

1.1	Calculate the electrical force, F_E , exerted by the plates on each other.	0.8
1.2	Let x be the displacement of the plate connected to the spring. Find x .	0.6
1.3	In this state, what is the electrical potential difference V between the plates of the capacitor in terms of Q , A , d , k ?	0.4
1.4	Let C be the capacitance of the capacitor, defined as the ratio of charge to potential difference. Find C/C_0 as a function of Q , A , d and k .	0.3
1.5	What is the total energy, U , stored in the system in terms of Q , A , d and k ?	0.6

Figure 2, shows a mass M which is attached to a conducting plate with negligible mass and also to two springs having identical spring constants k . The conducting plate can move back and forth in the space between two fixed conducting plates. All these plates are similar and have the same area A . Thus these three plates constitute two capacitors. As shown in Figure 2, the fixed plates are connected to the given potentials V and $-V$, and the middle plate is connected



through a two-state switch to the ground. The wire connected to the movable plate does not disturb the motion of the plate and the three plates will always remain parallel. When the whole complex is not being accelerated, the distance from each fixed plate to the movable plate is d which is much smaller than the dimensions of the plates. The thickness of the movable plate can be ignored.

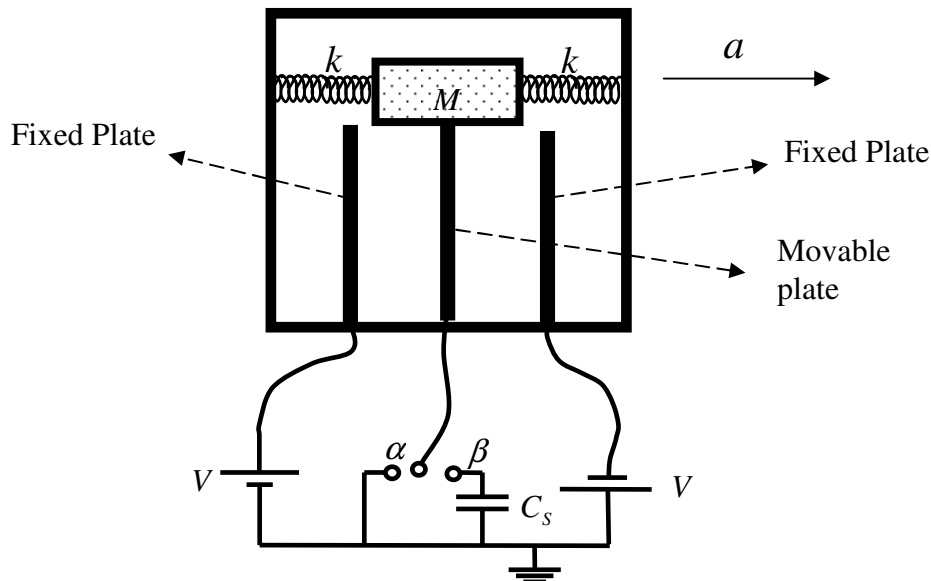

Figure 2

The switch can be in either one of the two states α and β . Assume that the capacitor complex is being accelerated along with the automobile, and the acceleration is constant. Assume that during this constant acceleration the spring does not oscillate and all components of this complex capacitor are in their equilibrium positions, i.e. they do not move with respect to each other, and hence with respect to the automobile.

Due to the acceleration, the movable plate will be displaced a certain amount x from the middle of the two fixed plates.

2 Consider the case where the switch is in state α i.e. the movable plate is connected to the ground through a wire, then

2.1	Find the charge on each capacitor as a function of x .	0.4
2.2	Find the net electrical force on the movable plate, F_E , as a function of x .	0.4
2.3	Assume $d \gg x$ and terms of order x^2 can be ignored compared to terms of order d^2 . Simplify the answer to the previous part.	0.2
2.4	Write the total force on the movable plate (the sum of the electrical and the spring forces) as $-k_{eff}x$ and give the form of k_{eff} .	0.7
2.5	Express the constant acceleration a as a function of x .	0.4



- 3 Now assume that the switch is in state β i.e. the movable plate is connected to the ground through a capacitor, the capacitance of which is C_s (there is no initial charge on the capacitors). If the movable plate is displaced by an amount x from its central position,

3.1	Find V_s the electrical potential difference across the capacitor C_s as a function of x .	1.5
-----	--	-----

3.2	Again assume that $d \gg x$ and ignore terms of order x^2 compared to terms of order d^2 . Simplify your answer to the previous part.	0.2
-----	---	-----

- 4 We would like to adjust the parameters in the problem such that the air bag will not be activated in normal braking but opens fast enough during a collision to prevent the driver's head from colliding with the windshield or the steering wheel. As you have seen in Part 2, the force exerted on the movable plate by the springs and the electrical charges can be represented as that of a spring with an effective spring constant k_{eff} . The whole capacitor complex is similar to a *mass and spring* system of mass M and spring constant k_{eff} under the influence of a constant acceleration a , which in this problem is the acceleration of the automobile.

Note: In this part of the problem, the assumption that the mass and spring are in equilibrium under a constant acceleration and hence are fixed relative to the automobile, no longer holds.

Ignore friction and consider the following numerical values for the parameters of the problem:

$$d = 1.0 \text{ cm}, \quad A = 2.5 \times 10^{-2} \text{ m}^2, \quad k = 4.2 \times 10^3 \text{ N/m}, \quad \epsilon_0 = 8.85 \times 10^{-12} \text{ C}^2/\text{Nm}^2, \\ V = 12 \text{ V}, \quad M = 0.15 \text{ kg}.$$

4.1	Using this data, find the ratio of the electrical force you calculated in section 2.3 to the force of the springs and show that one can ignore the electrical forces compared to the spring forces.	0.6
-----	---	-----

Although we did not calculate the electrical forces for the case when the switch is in the state β , it can be shown that in this situation, quite similarly, the electrical forces are as small and can be ignored.

4.2	If the automobile while traveling with a constant velocity, suddenly brakes with a constant acceleration a , what is the maximum displacement of the movable plate? Give your answer in parameter.	0.6
-----	--	-----

Assume that the switch is in state β and the system has been designed such that when the electrical voltage across the capacitor reaches $V_s = 0.15 \text{ V}$, the air bag is activated. We would like the air bag not to be activated during normal braking when the automobile's acceleration is less than the acceleration of gravity $g = 9.8 \text{ m/s}^2$, but be activated otherwise.

4.3	How much should C_s be for this purpose?	0.6
-----	--	-----



We would like to find out if the air bag will be activated fast enough to prevent the driver's head from hitting the windshield or the steering wheel. Assume that as a result of collision, the automobile experiences a deceleration equal to g but the driver's head keeps moving at a constant speed.

4.4	By estimating the distance between the driver's head and the steering wheel, find the time t_1 it takes before the driver's head hits the steering wheel.	0.8
4.5	Find the time t_2 before the air bag is activated and compare it to t_1 . Is the air bag activated in time? Assume that airbag opens instantaneously.	0.9



In physics, whenever we have an equality relation, both sides of the equation should be of the same type i.e. they must have the same dimensions. For example you cannot have a situation where the quantity on the right-hand side of the equation represents a length and the quantity on the left-hand side represents a time interval. Using this fact, sometimes one can nearly deduce the form of a physical relation without solving the problem analytically. For example if we were asked to find the time it takes for an object to fall from a height of h under the influence of a constant gravitational acceleration g , we could argue that one only needs to build a quantity representing a time interval, using the quantities g and h and the only possible way of doing this is $T = a(h/g)^{1/2}$. Notice that this solution includes an as yet undetermined coefficient a which is *dimensionless* and thus cannot be determined, using this method. This coefficient can be a number such as 1, $1/2$, $\sqrt{3}$, π , or any other real number. This method of deducing physical relations is called *dimensional analysis*. In dimensional analysis the dimensionless coefficients are not important and we do not need to write them. Fortunately in most physical problems these coefficients are of the order of 1 and eliminating them does not change the order of magnitude of the physical quantities. Therefore, by applying the dimensional analysis to the above problem, one obtains $T = (h/g)^{1/2}$.

Generally, the dimensions of a physical quantity are written in terms of the dimensions of four fundamental quantities: M (mass), L (length), T (time), and K (temperature). The dimensions of an arbitrary quantity, x is denoted by $[x]$. As an example, to express the dimensions of velocity v , kinetic energy E_k , and heat capacity C_v we write: $[v] = LT^{-1}$, $[E_k] = ML^2T^{-2}$, $[C_v] = ML^2T^{-2}K^{-1}$.

1 Fundamental Constants and Dimensional Analysis

1.1	Find the dimensions of <i>the fundamental constants</i> , i.e. the Planck's constant, h , the speed of light, c , the universal constant of gravitation, G , and the Boltzmann constant, k_B , in terms of the dimensions of length, mass, time, and temperature.	0.8
-----	---	-----

The Stefan-Boltzmann law states that the black body emissive power which is the total energy radiated per unit surface area of a black body in unit time is equal to $\sigma\theta^4$ where σ is the Stefan-Boltzmann's constant and θ is the absolute temperature of the black body.

1.2	Determine the dimensions of the Stefan-Boltzmann's constant in terms of the dimensions of length, mass, time, and temperature.	0.5
-----	--	-----

The Stefan-Boltzmann's constant is not a fundamental constant and one can write it in terms of fundamental constants i.e. one can write $\sigma = ah^\alpha c^\beta G^\gamma k_B^\delta$. In this relation a is a dimensionless parameter of the order of 1. As mentioned before, the exact value of a is not significant from our viewpoint, so we will set it equal to 1.

1.3	Find α , β , γ , and δ using dimensional analysis.	1.0
-----	---	-----



2 Physics of Black Holes

In this part of the problem, we would like to find out some properties of black holes using dimensional analysis. According to a certain theorem in physics known as the *no hair theorem*, all the characteristics of the black hole which we are considering in this problem depend only on the mass of the black hole. One characteristic of a black hole is the area of its *event horizon*. Roughly speaking, the event horizon is the boundary of the black hole. Inside this boundary, the gravity is so strong that even light cannot emerge from the region enclosed by the boundary.

We would like to find a relation between the mass of a black hole, m , and the area of its event horizon, A . This area depends on the mass of the black hole, the speed of light, and the universal constant of gravitation. As in 1.3 we shall write $A = G^\alpha c^\beta m^\gamma$.

2.1	Use dimensional analysis to find α , β , and γ .	0.8
-----	--	-----

From the result of 2.1 it becomes clear that the area of the event horizon of a black hole increases with its mass. From a classical point of view, nothing comes out of a black hole and therefore in all physical processes the area of the event horizon can only increase. In analogy with the second law of thermodynamics, Bekenstein proposed to assign entropy, S , to a black hole, proportional to the area of its event horizon i.e. $S = \eta A$. This conjecture has been made more plausible using other arguments.

2.2	Use the thermodynamic definition of entropy $dS = dQ/\theta$ to find the dimensions of entropy. dQ is the exchanged heat and θ is the absolute temperature of the system.	0.2
-----	---	-----

2.3	As in 1.3, express the dimensioned constant η as a function of the fundamental constants h , c , G , and k_B .	1.1
-----	---	-----

Do **not** use dimensional analysis for the rest of problem, but you may use the results you have obtained in previous sections.

3 Hawking Radiation

With a semi-quantum mechanical approach, Hawking argued that contrary to the classical point of view, black holes emit radiation similar to the radiation of a black body at a temperature which is called the *Hawking temperature*.

3.1	Use $E = mc^2$, which gives the energy of the black hole in terms of its mass, and the laws of thermodynamics to express the Hawking temperature θ_H of a black hole in terms of its mass and the fundamental constants. Assume that the black hole does no work on its surroundings.	0.8
-----	---	-----

3.2	The mass of an isolated black hole will thus change because of the Hawking radiation. Use Stefan-Boltzmann's law to find the dependence of this rate of change on the Hawking temperature of the black hole, θ_H and express it in terms of mass of the black hole and the fundamental constants.	0.7
-----	--	-----



3.3	Find the time t^* , that it takes an isolated black hole of mass m to evaporate completely i.e. to lose all its mass.	1.1
-----	---	-----

From the viewpoint of thermodynamics, black holes exhibit certain exotic behaviors. For example the heat capacity of a black hole is negative.

3.4	Find the heat capacity of a black hole of mass m .	0.6
-----	--	-----

4 Black Holes and the Cosmic Background Radiation

Consider a black hole exposed to the cosmic background radiation. The cosmic background radiation is a black body radiation with a temperature θ_B which fills the entire universe. An object with a total area A will thus receive an energy equal to $\sigma\theta_B^4 \times A$ per unit time. A black hole, therefore, loses energy through Hawking radiation and gains energy from the cosmic background radiation.

4.1	Find the rate of change of a black hole's mass, in terms of the mass of the black hole, the temperature of the cosmic background radiation, and the fundamental constants.	0.8
-----	--	-----

4.2	At a certain mass, m^* , this rate of change will vanish. Find m^* and express it in terms of θ_B and the fundamental constants.	0.4
-----	---	-----

4.3	Use your answer to 4.2 to substitute for θ_B in your answer to part 4.1 and express the rate of change of the mass of a black hole in terms of m , m^* , and the fundamental constants.	0.2
-----	--	-----

4.4	Find the Hawking temperature of a black hole at thermal equilibrium with cosmic background radiation.	0.4
-----	---	-----

4.5	Is the equilibrium stable or unstable? Why? (Express your answer mathematically)	0.6
-----	--	-----

Two stars rotating around their center of mass form a binary star system. Almost half of the stars in our galaxy are binary star systems. It is not easy to realize the binary nature of most of these star systems from Earth, since the distance between the two stars is much less than their distance from us and thus the stars cannot be resolved with telescopes. Therefore, we have to use either photometry or spectrometry to observe the variations in the intensity or the spectrum of a particular star to find out whether it is a binary system or not.

Photometry of Binary Stars

If we are exactly on the plane of motion of the two stars, then one star will occult (pass in front of) the other star at certain times and the intensity of the whole system will vary with time from our observation point. These binary systems are called ecliptic binaries.

- 1 Assume that two stars are moving on circular orbits around their common center of mass with a constant angular speed ω and we are exactly on the plane of motion of the binary system. Also assume that the surface temperatures of the stars are T_1 and T_2 ($T_1 > T_2$), and the corresponding radii are R_1 and R_2 ($R_1 > R_2$), respectively. The total intensity of light, measured on Earth, is plotted in Figure 1 as a function of time. Careful measurements indicate that the intensities of the incident light from the stars corresponding to the minima are respectively 90 and 63 percent of the maximum intensity, I_0 , received from both stars ($I_0 = 4.8 \times 10^{-9} \text{ W/m}^2$). The vertical axis in Figure 1 shows the ratio I/I_0 and the horizontal axis is marked in days.

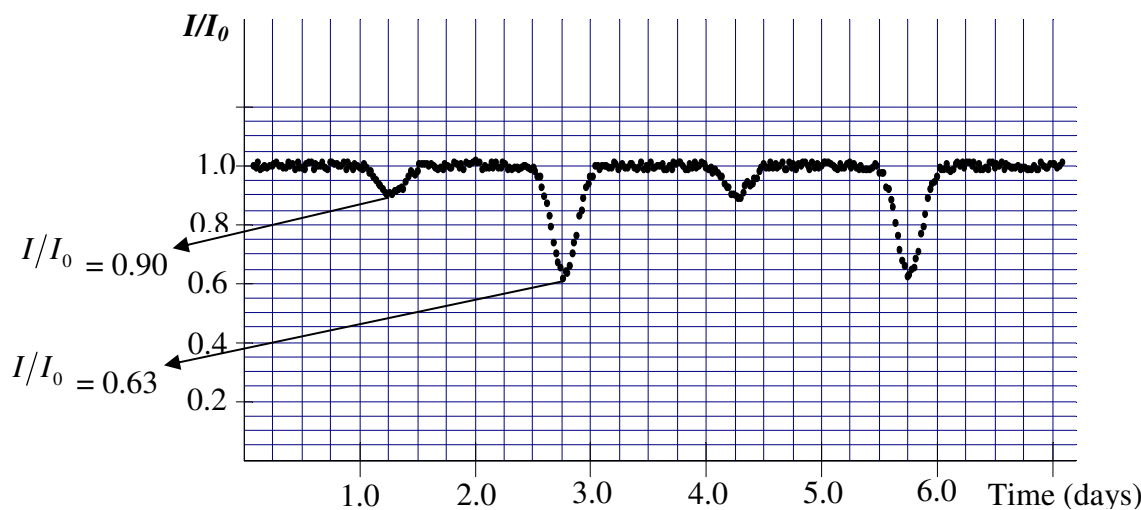

Figure 1. The relative intensity received from the binary star system as a function of time. The vertical axis has been scaled by $I_0 = 4.8 \times 10^{-9} \text{ W/m}^2$. Time is given in days.

1.1	Find the period of the orbital motion. Give your answer in seconds up to two significant digits. What is the angular frequency of the system in rad/sec ?	0.8
-----	--	-----



To a good approximation, the receiving radiation from a star is a uniform black body radiation from a flat disc with a radius equal to the radius of the star. Therefore, the power received from the star is proportional to AT^4 where A is area of the disc and T is the surface temperature of the star.

1.2	Use the diagram in Figure 1 to find the ratios T_1/T_2 and R_1/R_2 .	1.6
-----	--	-----

Spectrometry of Binary Systems

In this section, we are going to calculate the astronomical properties of a binary star by using experimental spectrometric data of the binary system.

Atoms absorb or emit radiation at their certain characteristic wavelengths. Consequently, the observed spectrum of a star contains *absorption lines* due to the atoms in the star's atmosphere. Sodium has a characteristic yellow line spectrum (D_1 line) with a wavelength 5895.9\AA ($10\text{\AA} = 1\text{ nm}$). We examine the absorption spectrum of atomic Sodium at this wavelength for the binary system of the previous section. The spectrum of the light that we receive from the binary star is Doppler-shifted, because the stars are moving with respect to us. Each star has a different speed. Accordingly the absorption wavelength for each star will be shifted by a different amount. Highly accurate wavelength measurements are required to observe the Doppler shift since the speed of the stars is much less than the speed of light. The speed of the center of mass of the binary system we consider in this problem is much smaller than the orbital velocities of the stars. Hence all the Doppler shifts can be attributed to the orbital velocity of the stars. Table 1 shows the measured spectrum of the stars in the binary system we have observed.

Table 1: Absorption spectrum of the binary star system for the Sodium D_1 line

t/days	0.3	0.6	0.9	1.2	1.5	1.8	2.1	2.4
λ_1 (\AA)	5897.5	5897.7	5897.2	5896.2	5895.1	5894.3	5894.1	5894.6
λ_2 (\AA)	5893.1	5892.8	5893.7	5896.2	5897.3	5898.7	5899.0	5898.1

t/days	2.7	3.0	3.3	3.6	3.9	4.2	4.5	4.8
λ_1 (\AA)	5895.6	5896.7	5897.3	5897.7	5897.2	5896.2	5895.0	5894.3
λ_2 (\AA)	5896.4	5894.5	5893.1	5892.8	5893.7	5896.2	5897.4	5898.7

(Note: There is no need to make a graph of the data in this table)

2 Using Table 1,

2.1	Let v_1 and v_2 be the orbital velocity of each star. Find v_1 and v_2 . The speed of light $c = 3.0 \times 10^8$ m/s. Ignore all relativistic effects.	1.8
2.2	Find the mass ratio of the stars (m_1/m_2).	0.7
2.3	Let r_1 and r_2 be the distances of each star from their center of mass. Find r_1 and r_2 .	0.8

2.4	Let r be the distance between the stars. Find r .	0.2
-----	---	-----

3 The gravitational force is the only force acting between the stars.

3.1	Find the mass of each star up to one significant digit. The universal gravitational constant $G = 6.7 \times 10^{-11} \text{ m}^3 \text{ kg}^{-1} \text{ s}^{-2}$.	1.2
-----	--	-----

General Characteristics of Stars

- 4 Most of the stars generate energy through the same mechanism. Because of this, there is an empirical relation between their mass, M , and their luminosity, L , which is the total radiant power of the star. This relation could be written in the form $L/L_{Sun} = (M/M_{Sun})^\alpha$. Here, $M_{Sun} = 2.0 \times 10^{30} \text{ kg}$ is the solar mass and, $L_{Sun} = 3.9 \times 10^{26} \text{ W}$ is the solar luminosity. This relation is shown in a log-log diagram in Figure 2.

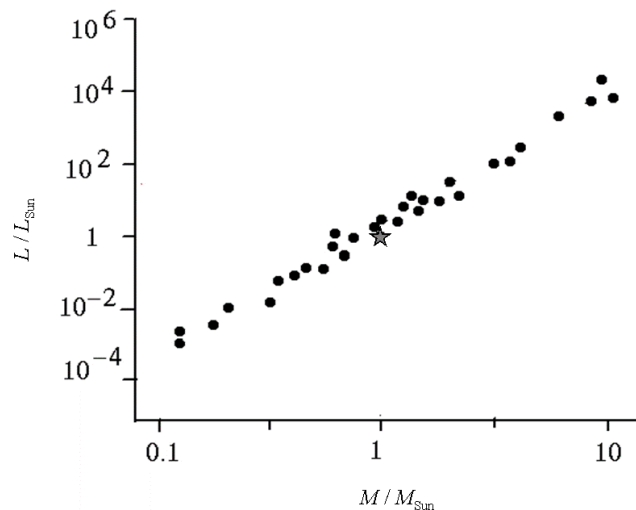

Figure 2. The luminosity of a star versus its mass varies as a power law. The diagram is log-log. The star-symbol represents Sun with a mass of $2.0 \times 10^{30} \text{ kg}$ and luminosity of $3.9 \times 10^{26} \text{ W}$.

4.1	Find α up to one significant digit.	0.6
-----	--	-----

4.2	Let L_1 and L_2 be the luminosity of the stars in the binary system studied in the previous sections. Find L_1 and L_2 .	0.6
-----	--	-----

4.3	What is the distance, d , of the star system from us in light years? To find the distance you can use the diagram of Figure 1. One light year is the distance light travels in one year.	0.9
-----	---	-----



4.4	What is the maximum angular distance, θ , between the stars from our observation point?	0.4
4.5	What is the smallest aperture size for an optical telescope, D , that can resolve these two stars?	0.4

Experimental Problem

Determination of energy band gap of semiconductor thin films

I. Introduction

Semiconductors can be roughly characterized as materials whose electronic properties fall somewhere between those of conductors and insulators. To understand semiconductor electronic properties, one can start with the *photoelectric effect* as a well-known phenomenon. The photoelectric effect is a quantum electronic phenomenon, in which photoelectrons are emitted from the matter through the absorption of sufficient energy from electromagnetic radiation (i.e. photons). The minimum energy which is required for the emission of an electron from a metal by light irradiation (*photoelectron*) is defined as "*work function*". Thus, only photons with a frequency ν higher than a characteristic threshold, i.e. with an energy $h\nu$ (h is the Planck's constant) more than the material's work function, are able to knock out the photoelectrons.

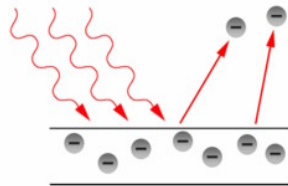

Figure 1. An illustration of photoelectron emission from a metal plate: The incoming photon should have an energy which is more than the work function of the material.

In fact, the concept of work function in the photoelectric process is similar to the concept of the energy band gap of a semiconducting material. In solid state physics, the band gap E_g is the energy difference between the top of the valence band and the bottom of the conduction band of insulators and semiconductors. The valence band is completely filled with electrons, while the conduction band is empty however electrons can go from the valence band to the conduction band if they acquire sufficient energy (at least equal to the band gap energy). The semiconductor's conductivity strongly depends on its energy band gap.

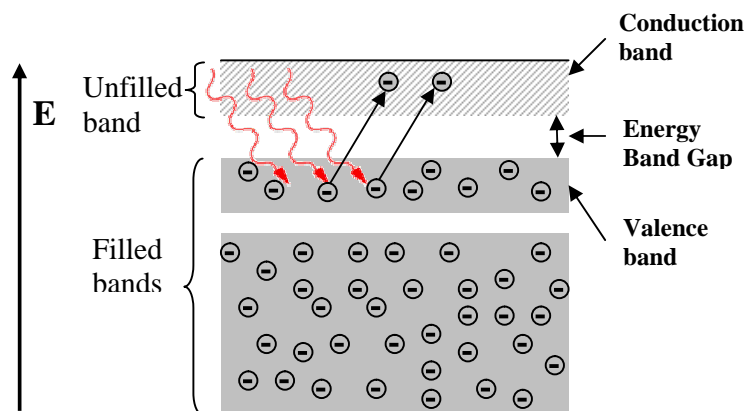

Figure 2. Energy band scheme for a semiconductor.

Band gap engineering is the process of controlling or altering the band gap of a material by controlling the composition of certain semiconductor alloys. Recently, it has been shown that by changing the nanostructure of a semiconductor it is possible to manipulate its band gap.

In this experiment, we are going to obtain the energy band gap of a thin-film semiconductor containing nano-particle chains of iron oxide (Fe_2O_3) by using an optical method. To measure the band gap, we study the optical absorption properties of the transparent film using its optical transmission spectrum. As a rough statement, the absorption spectra shows a sharp increase when the energy of the incident photons equals to the energy band gap.

II. Experimental Setup

You will find the following items on your desk:

1. A large white box containing a spectrometer with a halogen lamp.
2. A small box containing a sample, a glass substrate, a sample-holder, a grating, and a photoresistor.
3. A multimeter.
4. A calculator.
5. A ruler.
6. A card with a hole punched in its center.
7. A set of blank labels.

The spectrometer contains a goniometer with a precision of $5'$. The Halogen lamp acts as the source of radiation and is installed onto the fixed arm of the spectrometer (for detailed information see the enclosed "Description of Apparatus").

The small box contains the following items:

1. A sample-holder with two windows: a glass substrate coated with Fe_2O_3 film mounted on one window and an uncoated glass substrate mounted on the other.
2. A photoresistor mounted on its holder, which acts as a light detector.
3. A transparent diffraction grating (600 line/mm).

Note: Avoid touching the surface of any component in the small box!

A schematic diagram of the setup is shown in Figure 3:

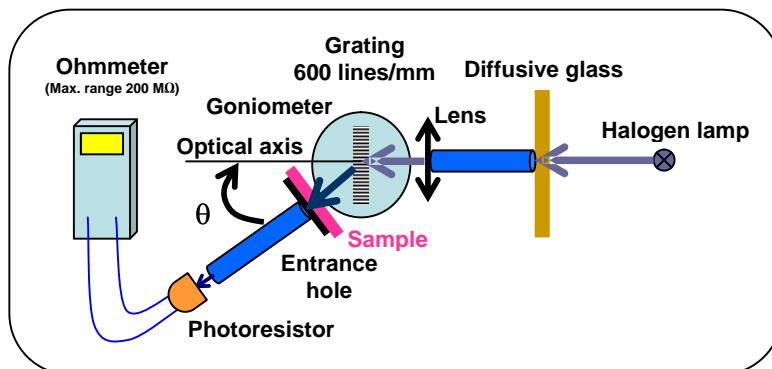

Figure 3. Schematic diagram of the experimental setup.

III. Methods

To obtain the transmission of a film at each wavelength, $T_{film}(\lambda)$, one can use the following formula:

$$T_{film}(\lambda) = I_{film}(\lambda) / I_{glass}(\lambda) \quad (1)$$

where I_{film} and I_{glass} are respectively the intensity of the light transmitted from the coated glass substrate, and the intensity of the light transmitted from the uncoated glass slide. The value of I can be measured using a light detector such as a photoresistor. In a photoresistor, the electrical resistance decreases when the intensity of the incident light increases. Here, the value of I can be determined from the following relation:

$$I(\lambda) = C(\lambda)R^{-1} \quad (2)$$

where R is the electrical resistance of the photoresistor, C is a λ -dependent coefficient.

The transparent grating on the spectrometer diffracts different wavelengths of light into different angles. Therefore, to study the variations of T as a function of λ , it is enough to change the angle of the photoresistor (θ') with respect to the optical axis (defined as the direction of the incident light beam on the grating), as shown in Figure 4.

From the principal equation of a diffraction grating:

$$n\lambda = d[\sin(\theta' - \theta_o) + \sin \theta_o] \quad (3)$$

one can obtain the angle θ' corresponding to a particular λ : n is an integer number representing the order of diffraction, d is the period of the grating, and θ_o is the angle the normal vector to the surface of grating makes with the optical axis (see Fig. 4). (In this experiment we shall try to place the grating perpendicular to the optical axis making $\theta_o = 0$, but since this cannot be achieved with perfect precision the error associated with this adjustment will be measured in task 1-e.)

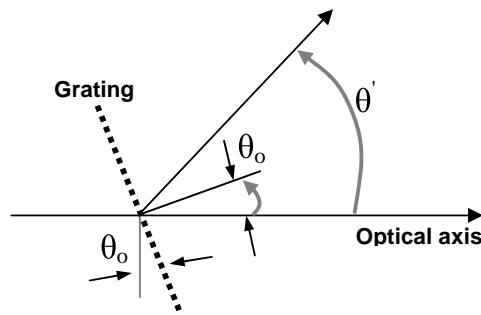

Figure 4. Definition of the angles involved in Equation 3.

Experimentally it has been shown that for photon energies slightly larger than the band gap energy, the following relation holds:

$$\alpha h\nu = A(h\nu - E_g)^\eta \quad (4)$$

where α is the absorption coefficient of the film, A is a constant that depends on the film's material, and η is the constant determined by the absorption mechanism of the film's material and structure. Transmission is related to the value of α through the well-known absorption relation:



$$T_{film} = \exp(-\alpha t) \quad (5)$$

where t is thickness of the film.

IV. Tasks:

0. Your apparatus and sample box (small box containing the sample holder) are marked with numbers. Write down the **Apparatus number** and **Sample number** in their appropriate boxes, in the answer sheet.

1. Adjustments and Measurements:

1-a	Check the vernier scale and report the maximum precision ($\Delta\theta$).	0.1 pt
------------	--	--------

Note: Magnifying glasses are available on request.

Step1:

To start the experiment, turn on the Halogen lamp to warm up. It would be better not to turn off the lamp during the experiment. Since the halogen lamp heats up during the experiment, please be careful not to touch it.

Place the lamp as far from the lens as possible, this will give you a parallel light beam.

We are going to make a rough zero-adjustment of the goniometer without utilizing the photoresistor. Unlock the rotatable arm with screw 18 (underneath the arm), and visually align the rotatable arm with the optical axis. Now, firmly lock the rotatable arm with screw 18. Unlock the vernier with screw 9 and rotate the stage to 0 on the vernier scale. Now firmly lock the vernier with screw 9 and use the vernier fine-adjustment screw (screw 10) to set the zero of the vernier scale. Place the grating inside its holder. Rotate the grating's stage until the diffraction grating is roughly perpendicular to the optical axis. Place the card with a hole in front of the light source and position the hole such that a beam of light is incident on the grating. Carefully rotate the grating so that the spot of reflected light falls onto the hole. Then the reflected light beam coincides with the incident beam. Now lock the grating's stage by tightening screw 12.

1-b	By measuring the distance between the hole and the grating, estimate the precision of this adjustment ($\Delta\theta_o$).	0.3 pt
	Now, by rotating the rotatable arm, determine and report the range of angles for which the first-order diffraction of visible light (from blue to red) is observed.	0.2 pt

Step 2:

Now, install the photoresistor at the end of the rotatable arm. To align the system optically, by using the photoresistor, loosen the screw 18, and slightly turn the rotatable arm so that the photoresistor shows a minimum resistance. For fine positioning, firmly lock screw 18, and use the fine adjustment screw of the rotatable arm.



Use the vernier fine-adjustment screw to set the zero of the vernier scale.

1-c	Report the measured minimum resistance value ($R_{\min}^{(0)}$).	0.1 pt
	Your zero-adjustment is more accurate now, report the precision of this new adjustment ($\Delta\varphi_o$). Note: $\Delta\varphi_o$ is the error in this alignment i.e. it is a measure of misalignment of the rotatable arm and the optical axis.	0.1 pt

- **Hint:** After this task you should tighten the fixing screws of the vernier. Moreover, tighten the screw of the photoresistor holder to fix it and do not remove it during the experiment.

Step 3:

Move the rotatable arm to the region of the first-order diffraction. Find the angle at which the resistance of the photoresistor is minimum (maximum light intensity). Using the balancing screws, you can slightly change the *tilt* of the grating's stage, to achieve an even lower resistance value.

1-c	Report the minimum value of the observed resistance ($R_{\min}^{(1)}$) in its appropriate box.	0.1 pt
------------	--	--------

It is now necessary to check the perpendicularity of the grating for zero adjustment, again. For this you must use the reflection-coincidence method of Step 1.

Important: From here onwards carry out the experiment in dark (close the cover).

Measurements: Screw the sample-holder onto the rotatable arm. Before you start the measurements, examine the appearance of your semiconductor film (sample). Place the sample in front of the entrance hole S_1 on the rotatable arm such that a uniformly coated part of the sample covers the hole. To make sure that every time you will be working with the same part of the sample make proper markings on the sample holder and the rotatable arm with blank labels.

Attention: At higher resistance measurements it is necessary to allow the photoresistor to relax, therefore for each measurement in this range wait 3 to 4 minutes before recording your measurement.

1-d	Measure the resistance of the photoresistor for the uncoated glass substrate and the glass substrate coated with semiconductor layer as a function of the angle θ (the value read by the goniometer for the angle between the photoresistor and your specified optical axis). Then fill in Table 1d. Note that you need at least 20 data points in the range you found in Step 1b. Carry out your measurement using the appropriate range of your ohmmeter.	2.0 pt
	Consider the error associated with each data point. Base your	1.0 pt



	answer only on your direct readings of the ohmmeter.	
--	--	--

Step 4:

The precision obtained so far is still limited since it is impossible to align the rotatable arm with the optical axis and/or position the grating perpendicular to the optical axis with 100% precision. So we still need to find the asymmetry of the measured transmission at both sides of the optical axis (resulting from the deviation of the normal to the grating surface from the optical axis (θ_o)).

To measure this asymmetry, follow these steps:

1-e	First, measure T_{film} at $\theta = -20^\circ$. Then, obtain values for T_{film} at some other angles around $+20^\circ$. Complete Table 1e (you can use the values obtained in Table 1d).	<i>0.6 pt</i>
	Draw T_{film} versus θ and visually draw a curve.	<i>0.6 pt</i>

On your curve find the angle γ for which the value of T_{film} is equal to the T_{film} that you measured at $\theta = -20^\circ$ ($\gamma \equiv \theta|_{T_{film} = T_{film}(-20^\circ)}$). Denote the difference of this angle with $+20^\circ$ as δ , in other words:

$$\delta = \gamma - 20^\circ \quad (6)$$

1-e	Report the value of δ in the specified box.	<i>0.2 pt</i>
------------	--	---------------

Then for the first-order diffraction, Eq. (3) can be simplified as follows:

$$\lambda = d \sin(\theta - \delta/2), \quad (7)$$

where θ is the angle read on the goniometer.

2. Calculations:

2-a	Use Eq. (7) to express $\Delta\lambda$ in terms of the errors of the other parameters (assume d is exact and there is no error is associated with it). Also using Eqs. (1), (2), and (5), express ΔT_{film} in terms of R and ΔR .	<i>0.6 pt</i>
------------	--	---------------

2-b	Report the range of values of $\Delta\lambda$ over the region of first-order diffraction.	<i>0.3 pt</i>
------------	---	---------------

2-c	Based on the measured parameters in Task 1, complete Table 2c for each θ . Note that the wavelength should be calculated using Eq. (7).	<i>2.4 pt</i>
------------	--	---------------

2-d	Plot R_{glass}^{-1} and R_{film}^{-1} as a function of wavelength together on the same diagram. Note that on the basis of Eq. (2) behaviors of R_{glass}^{-1} and R_{film}^{-1} can reasonably give us an indication of the way I_{glass} and I_{film} behave, respectively.	<i>1.5 pt</i>
	In Table 2d, report the wavelengths at which R_{glass} and R_{film} attain their minimum values.	<i>0.4 pt</i>



2-e	For the semiconductor layer (sample) plot T_{film} as a function of wavelength. This quantity also represents the variation of the film transmission in terms of wavelength.	1.0 pt
-----	--	--------

3. Data analysis:

By substituting $\eta = 1/2$ and $A = 0.071 \text{ ((eV)}^{1/2}/\text{nm})$ in Eq. (4) one can find values for E_g and t in units of eV and nm, respectively. This will be accomplished by plotting a suitable diagram in an $x - y$ coordinate system and doing an extrapolation in the region satisfying this equation.

3-a	By assuming $x = h\nu$ and $y = (\alpha t h\nu)^2$ and by using your measurements in Task 1, fill in Table 3a for wavelengths around 530 nm and higher. Express your results (x and y) with the correct number of significant figures (digits), based on the estimation of the error on one single data point. <u>Note that $h\nu$ should be calculated in units of eV and wavelength in units of nm.</u> Write the unit of each variable between the parentheses in the top row of the table.	2.4 pt
-----	--	--------

3-b	Plot y versus x .	2.6 pt
	Note that the y parameter corresponds to the absorption of the film. Fit a line to the points in the linear region around 530 nm.	
	Specify the region where Eq. (4) is satisfied, by reporting the values of the smallest and the largest x -coordinates for the data points to which you fit the line.	

3-c	Call the slope of this line m , and find an expression for the film thickness (t) and its error (Δt) in terms of m and A (consider A to have no error).	0.5 pt
-----	---	--------

3-d	Obtain the values of E_g and t and their associated errors in units of eV and nm, respectively. Fill in Table 3d.	3.0 pt
-----	---	--------

❖ Some useful physical constants required for your analysis:

- Speed of the light: $c = 3.00 \times 10^8 \text{ m/s}$
- Planck's constant: $h = 6.63 \times 10^{-34} \text{ J.s}$
- Electron charge: $e = 1.60 \times 10^{-19} \text{ C}$

Description of the Apparatus

In Fig.1 you can see the general view of the apparatus set up on your desk, which will be used in the experiment. The instrument is a spectroscope to be equipped with a detector to act as a simple spectrometer.

To start adjusting the apparatus, you should first pull up the white cover of the box (Fig.1). The cover pivots on one side of the base of the apparatus. In order to establish a dark environment for the detector, the cover should be returned to its initial position and kept tightly closed during the measurement of the spectra. The power cord has a switch that turns the halogen lamp on and off. There are four screws to level the apparatus (a magnified view of which you can see in right inset of Fig.1)

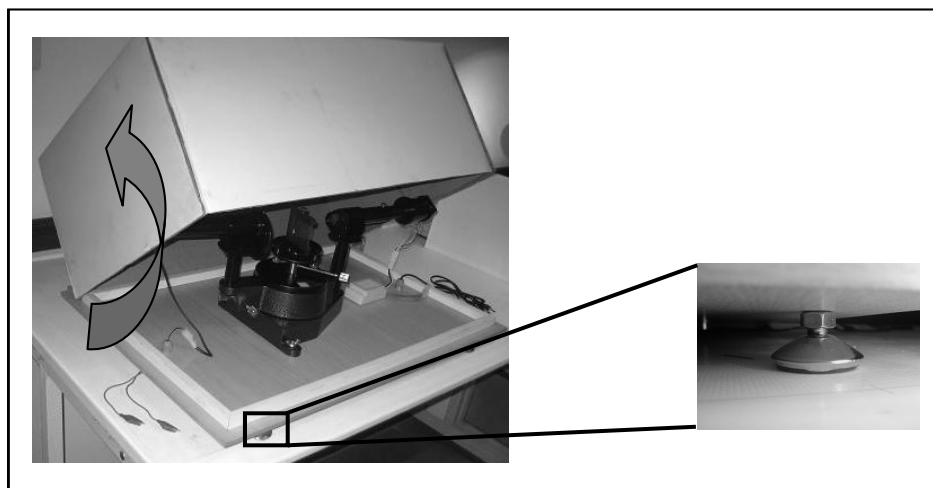

Figure 1. Apparatus of the experiment. One of the level adjusting screws is enlarged in the right inset.



Warning 1: Avoid touching the halogen lamp and its holder which will be **hot** after the lamp is turned on!



Warning 2: Do not manipulate the adaptor and its connections. Power is supplied to the apparatus through 220 V outlets!

The top view of the apparatus is shown in Fig.2 . The details are introduced in the figure.

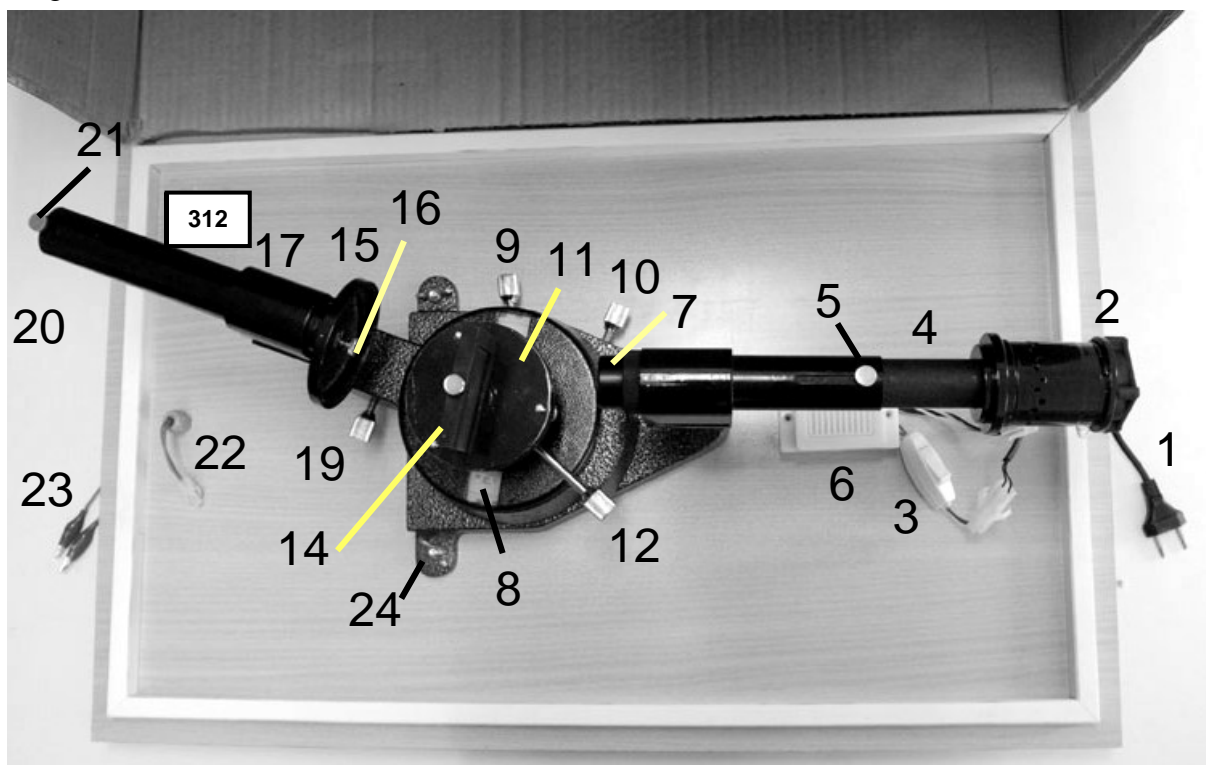

Figure 2.

- | | |
|---|---|
| 1. Power cord | 14. Grating holder |
| 2. Halogen lamp and its cooling fan | 15. Sample holder |
| 3. On/Off switch | 16. Fixing and adjusting screw for the sample and glass holder (Fig. 6) |
| 4. Arm of adjustable length | 17. Rotatable arm |
| 5. Adjusting screw | 18. Rotatable arm's lock (Fig.4) |
| 6. Adaptor: 220V – less than 12 V | 19. Fine adjustment for the rotatable arm |
| 7. Lens | 20. Detector position |
| 8. Vernier | 21. Fixing screw for the detector |
| 9. Vernier's lock | 22. Connecting socket for the detector |
| 10. Fine adjustment screw for the vernier | 23. Connection to the multimeter |
| 11. Grating's stage | 24. Fixing screw to the base |
| 12. Grating's stage's fixing screw | |
| 13. Adjustment screw for leveling the grating's stage (shown in Fig. 4) | |

The number mentioned on the top-left corner, is the **apparatus number**.

The angle, which the rotatable arm makes with the direction of the fixed arm of the apparatus, could be measured by a protractor equipped by a vernier. In this vernier resolution scale is 30' (minutes of arc). This instrument is able to measure an angle with accuracy of 5'.

In addition to the apparatus you should find a box (Figure 3), containing the following elements:

1: a detector in its holder; 2: a 600 line/mm grating; 3: the sample and a glass substrate mounted in a frame.

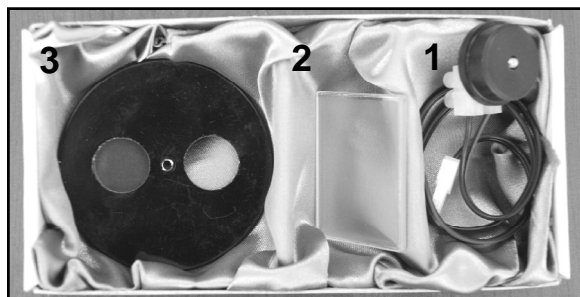

Figure 3. The small box, containing the glass and sample holder, a diffraction grating and a photoresistor.

First, you should take the grating out of its cover and put it into its frame (the grating holder, Fig. 4), carefully.

CAUTION: Touching the surface of the grating could reduce its diffraction efficiency seriously, or even damage it!

There are three adjustment screws (Fig. 4) for making the grating stand vertically in its position.

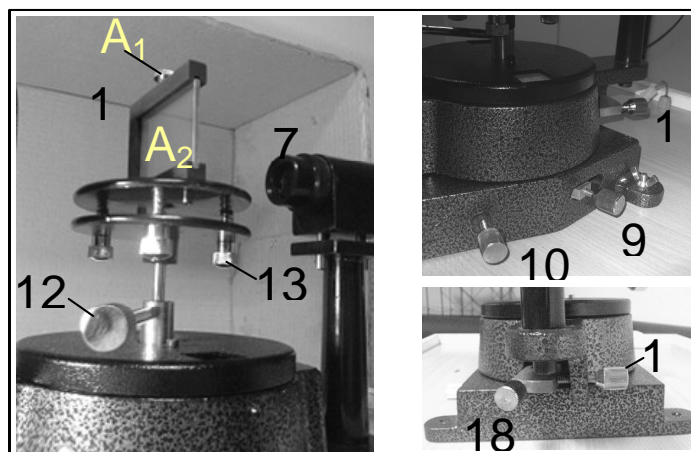

Figure 4. Locking, fixing and adjusting screws of the apparatus. A_1 : Fixing screw for the grating; A_2 : The grating. 7, 9, 10, 12-14, 18 and 19 are explained in Figure 2.

The detector should be tight to its position, in the end of the rotatable arm, (Figure 5):

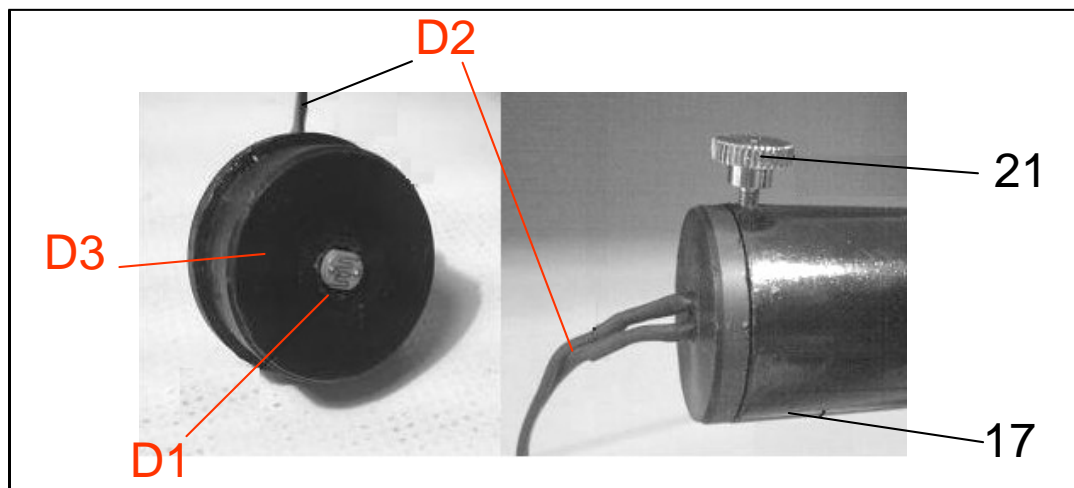

Figure 5 . The detector and its holder. D1: The photoresistor; D2: connecting wire. D3: The detector holder. 17 and 21 are explained in Fig. 2.

The sample and the glass substrate are fixed to a frame (holder) (Fig. 6c), which would be attached to the instrument by a fixing screw (Fig. 6a, item 16). This frame is rotatable and one can put the sample or the glass substrate in front of the entrance hole, by turning the frame around the fixing screw (Fig. 6a).

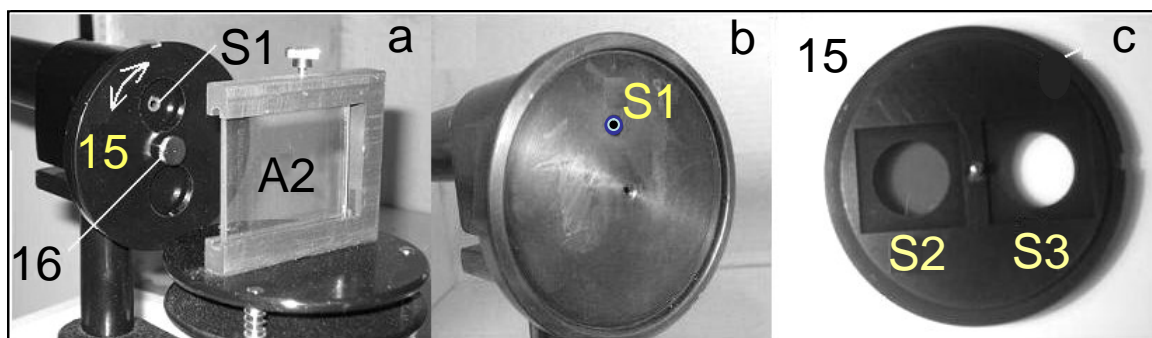

Figure 6 . The Sample and the glass holder. S1: Entrance hole; S2: Sample; S3: Glass substrate. 15 and 16 are explained in Fig. 2.

The Multimeter which you should use for recording the signal detected by the photoresistor is shown in the Fig. 7. This multimeter can measure up to 200 M Ω . The red and black probe wires should be connected to the instrument as is shown in the Fig. 7. The on/off button is placed on the left hand side of the multimeter (Fig. 7, item M1).

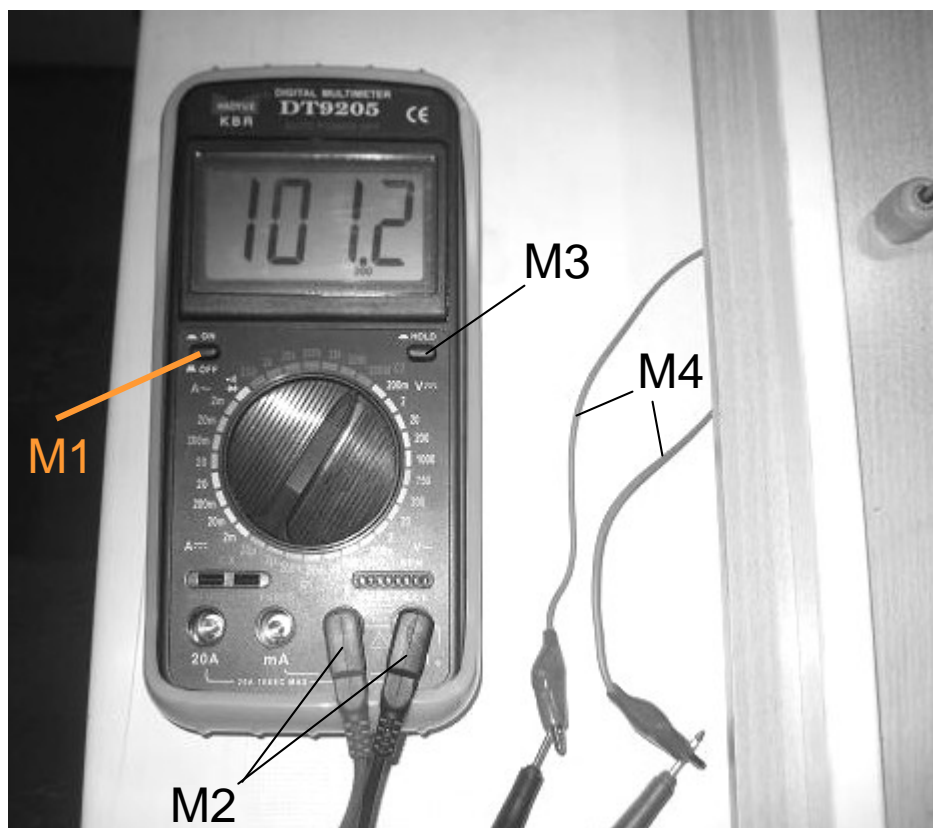

Figure 7. The Multimeter for measuring the resistance of the photoresistor. M1: on/off switch; M2: probe wires; M3: Hold button; M4: connections to the apparatus.

Note: The multimeter has auto-off feature. In the case of auto-off, you should push on/off button (M1) twice, successively.

❖ Hold button should not be active during the experiment.

Question “Orange”

1.1)

First of all, we use the Gauss’s law for a single plate to obtain the electric field,

$$E = \frac{\sigma}{\epsilon_0}. \quad (0.2)$$

The density of surface charge for a plate with charge, Q and area, A is

$$\sigma = \frac{Q}{A}. \quad (0.2)$$

Note that the electric field is resulted by two equivalent parallel plates. Hence the contribution of each plate to the electric field is $\frac{1}{2}E$. Force is defined by the electric field times the charge, then we have

$$\text{Force} = \frac{1}{2}EQ = \frac{Q^2}{2\epsilon_0 A} \quad (0.2) + (0.2) \quad (\text{The } \frac{1}{2} \text{ coefficient} + \text{the final result})$$

1.2)

The Hook’s law for a spring is

$$F_m = -kx. \quad (0.2)$$

In 1.2 we derived the electric force between two plates is

$$F_e = \frac{Q^2}{2\epsilon_0 A}.$$

The system is stable. The equilibrium condition yields

$$F_m = F_e, \quad (0.2)$$

$$\Rightarrow x = \frac{Q^2}{2\epsilon_0 A k} \quad (0.2)$$

1.3)

The electric field is constant thus the potential difference, V is given by

$$V = E(d - x) \quad (0.2)$$

(Other reasonable approaches are acceptable. For example one may use the definition of capacity to obtain V .)

By substituting the electric field obtained from previous section to the above equation, we

$$\text{get, } V = \frac{Qd}{\epsilon_0 A} \left(1 - \frac{Q^2}{2\epsilon_0 A k d} \right) \quad (0.2)$$

1.4)

C is defined by the ratio of charge to potential difference, then

$$C = \frac{Q}{V}. \quad (0.1)$$

Using the answer to 1.3, we get $\frac{C}{C_0} = \left(1 - \frac{Q^2}{2\epsilon_0 A k d}\right)^{-1}$ (0.2)

1.5)

Note that we have both the mechanical energy due to the spring

$$U_m = \frac{1}{2} k x^2, \quad (0.2)$$

and the electrical energy stored in the capacitor.

$$U_E = \frac{Q^2}{2C}. \quad (0.2)$$

Therefore the total energy stored in the system is

$$U = \frac{Q^2 d}{2\epsilon_0 A} \left(1 - \frac{Q^2}{4\epsilon_0 A k d}\right) \quad (0.2)$$

2.1)

For the given value of x , the amount of charge on each capacitor is

$$Q_1 = V C_1 = \frac{\epsilon_0 A V}{d - x}, \quad (0.2)$$

$$Q_2 = V C_2 = \frac{\epsilon_0 A V}{d + x}. \quad (0.2)$$

2.2)

Note that we have two capacitors. By using the answer to 1.1 for each capacitor, we get

$$F_1 = \frac{Q_1^2}{2\epsilon_0 A},$$

$$F_2 = \frac{Q_2^2}{2\epsilon_0 A}.$$

As these two forces are in the opposite directions, the net electric force is

$$F_E = F_1 - F_2, \quad (0.2) \quad \Rightarrow \quad F_E = \frac{\epsilon_0 A V^2}{2} \left(\frac{1}{(d-x)^2} - \frac{1}{(d+x)^2} \right) \quad (0.2)$$

2.3)

Ignoring terms of order x^2 in the answer to 2.2., we get

$$F_E = \frac{2\epsilon_0 A V^2}{d^3} x \quad (0.2)$$

2.4)

There are two springs placed in series with the same spring constant, k , then the mechanical force is

$$F_m = -2kx. \quad (\text{The coefficient (2) has (0.2)})$$

Combining this result with the answer to 2.4 and noticing that these two forces are in the opposite directions, we get

$$F = F_m + F_E, \quad \Rightarrow \quad F = -2 \left(k - \frac{\epsilon_0 A V^2}{d^3} \right) x, \quad (\text{Opposite signs of the two forces have (0.3)})$$

$$\Rightarrow k_{\text{eff}} = 2 \left(k - \frac{\epsilon_0 A V^2}{d^3} \right) \quad (0.2)$$

2.5)

By using the Newton's second law,

$$F = ma \quad (0.2)$$

and the answer to 2.4, we get

$$a = -\frac{2}{m} \left(k - \frac{\epsilon_0 A V^2}{d^3} \right) x \quad (0.2)$$

3.1)

Starting with Kirchhoff's laws, for two electrical circuits, we have

$$\left\{ \begin{array}{l} \frac{Q_s}{C_s} + V - \frac{Q_2}{C_2} = 0 \\ -\frac{Q_s}{C_s} + V - \frac{Q_1}{C_1} = 0 \\ Q_2 - Q_1 + Q_s = 0 \end{array} \right. \quad (\text{Each has (0.3), Note: the signs may depend on the specific choice made})$$

Noting that $V_s = \frac{Q_s}{C_s}$ one obtains

$$\Rightarrow V_s = V \frac{\frac{2\epsilon_0 A x}{d^2 - x^2}}{C_s + \frac{2\epsilon_0 A d}{d^2 - x^2}} \quad ((0.4) + (0.2): (0.4) \text{ for solving the above equations and (0.2)})$$

for final result)

Note: Students may simplify the above relation using the approximation $d^2 \gg x^2$. It does not matter in this section.

3.2)

Ignoring terms of order x^2 in the answer to 3.1., we get

$$V_S = V \frac{2\epsilon_0 A x}{d^2 C_S + 2\epsilon_0 A d} . \quad (0.2)$$

4.1)

The ratio of the electrical force to the mechanical (spring) force is

$$\frac{F_E}{F_m} = \frac{\epsilon_0 A V^2}{k d^3} ,$$

Putting the numerical values:

$$\frac{F_E}{F_m} = 7.6 \times 10^{-9} . \quad ((0.2) + (0.2) + (0.2): (0.2) \text{ for order of magnitude, } (0.2) \text{ for}$$

two significant digits and (0.2) for correct answer (7.6 or 7.5)).

As it is clear from this result, we can ignore the electrical forces compared to the electric force.

4.2)

As seen in the previous section, one may assume that the only force acting on the moving plate is due to springs:

$$F = 2k x . \quad (\text{The concept of equilibrium } (0.2))$$

Hence in mechanical equilibrium, the displacement of the moving plate is

$$x = \frac{ma}{2k} .$$

The maximum displacement is twice this amount, like the mass spring system in a gravitational force field, when the mass is let to fall.

$$x_{\max} = 2x \quad (0.2)$$

$$x_{\max} = \frac{ma}{k} \quad (0.2)$$

4.3)

At the acceleration

$$a = g , \quad (0.2)$$

The maximum displacement is

$$x_{\max} = \frac{mg}{k} .$$

Moreover, from the result obtained in 3.2, we have

$$V_s = V \frac{2\epsilon_0 A x_{\max}}{d^2 C_s + 2\epsilon_0 A d}$$

This should be the same value given in the problem, 0.15 V .

$$\Rightarrow C_s = \frac{2\epsilon_0 A}{d} \left(\frac{V x_{\max}}{V_s d} - 1 \right) \quad (0.2)$$

$$\Rightarrow C_s = 8.0 \times 10^{-11} \text{ F} \quad (0.2)$$

4.4)

Let ℓ be the distance between the driver's head and the steering wheel. It can be estimated to be about

$$\ell = 0.4 \text{ m} - 1 \text{ m} . \quad (0.2)$$

Just at the time the acceleration begins, the relative velocity of the driver's head with respect to the automobile is zero.

$$\Delta v(t=0) = 0, \quad (0.2)$$

then

$$\ell = \frac{1}{2} g t_1^2 \quad \Rightarrow \quad t_1 = \sqrt{\frac{2\ell}{g}} \quad (0.2)$$

$$t_1 = 0.3 - 0.5 \text{ s} \quad (0.2)$$

4.5)

The time t_2 is half of period of the harmonic oscillator, hence

$$t_2 = \frac{T}{2}, \quad (0.3)$$

The period of harmonic oscillator is simply given by

$$T = 2\pi \sqrt{\frac{m}{2k}}, \quad (0.2)$$

therefore,

$$t_2 = 0.013 \text{ s} . \quad (0.2)$$

As $t_1 > t_2$, the airbag activates in time. (0.2)

1.1) One may use any reasonable equation to obtain the dimension of the questioned quantities.

$$\text{I) The Planck relation is } h\nu = E \Rightarrow [h][\nu] = [E] \Rightarrow [h] = [E][\nu]^{-1} = ML^2T^{-1} \quad (0.2)$$

$$\text{II) } [c] = LT^{-1} \quad (0.2)$$

$$\text{III) } F = \frac{Gmm}{r^2} \Rightarrow [G] = [F][r^2][m]^{-2} = M^{-1}L^3T^{-2} \quad (0.2)$$

$$\text{IV) } E = K_B\theta \Rightarrow [K_B] = [\theta]^{-1}[E] = ML^2T^{-2}K^{-1} \quad (0.2)$$

1.2) Using the Stefan-Boltzmann's law,

$$\frac{\text{Power}}{\text{Area}} = \sigma\theta^4, \text{ or any equivalent relation, one obtains:} \quad (0.3)$$

$$[\sigma]K^4 = [E]L^{-2}T^{-1} \Rightarrow [\sigma] = MT^{-3}K^{-4}. \quad (0.2)$$

1.3) The Stefan-Boltzmann's constant, up to a numerical coefficient, equals

$$\sigma = h^\alpha c^\beta G^\gamma k_B^\delta, \text{ where } \alpha, \beta, \gamma, \delta \text{ can be determined by dimensional analysis. Indeed, } [\sigma] = [h]^\alpha [c]^\beta [G]^\gamma [k_B]^\delta, \text{ where e.g. } [\sigma] = MT^{-3}K^{-4}.$$

$$MT^{-3}K^{-4} = (ML^2T^{-1})^\alpha (LT^{-1})^\beta (M^{-1}L^3T^{-2})^\gamma (ML^2T^{-2}K^{-1})^\delta = M^{\alpha-\gamma+\delta} L^{2\alpha+\beta+3\gamma+2\delta} T^{-\alpha-\beta-2\gamma-2\delta} K^{-\delta}, \quad (0.2)$$

The above equality is satisfied if,

$$\Rightarrow \begin{cases} \alpha - \gamma + \delta = 1, \\ 2\alpha + \beta + 3\gamma + 2\delta = 0, \\ -\alpha - \beta - 2\gamma - 2\delta = -3, \\ -\delta = -4, \end{cases} \quad (\text{Each one (0.1)}) \Rightarrow \begin{cases} \alpha = -3, \\ \beta = -2, \\ \gamma = 0, \\ \delta = 4. \end{cases} \quad (\text{Each one (0.1)})$$

$$\Rightarrow \sigma = \frac{k_B^4}{c^2 h^3}.$$

2.1) Since A , the area of the event horizon, is to be calculated in terms of m from a classical theory of relativistic gravity, e.g. the General Relativity, it is a combination of c , characteristic of special relativity, and G characteristic of gravity. Especially, it is

independent of the Planck constant h which is characteristic of quantum mechanical phenomena.

$$A = G^\alpha c^\beta m^\gamma$$

Exploiting dimensional analysis,

$$\Rightarrow [A] = [G]^\alpha [c]^\beta [m]^\gamma \Rightarrow L^2 = (M^{-1}L^3T^{-2})^\alpha (LT^{-1})^\beta M^\gamma = M^{-\alpha+\gamma} L^{3\alpha+\beta} T^{-2\alpha-\beta} \quad (0.2)$$

The above equality is satisfied if,

$$\Rightarrow \begin{cases} -\alpha + \gamma = 0, \\ 3\alpha + \beta = 2, \\ -2\alpha - \beta = 0, \end{cases} \quad (\text{Each one (0.1)}) \Rightarrow \begin{cases} \alpha = 2, \\ \beta = -4, \\ \gamma = 2, \end{cases} \quad (\text{Each one (0.1)}) \Rightarrow$$

$$A = \frac{m^2 G^2}{c^4}.$$

2.2)

From the definition of entropy $dS = \frac{dQ}{\theta}$, one obtains $[S] = [E][\theta]^{-1} = ML^2T^{-2}K^{-1}$ (0.2)

2.3) Noting $\eta = S/A$, one verifies that,

$$\begin{cases} [\eta] = [S][A]^{-1} = MT^{-2}K^{-1}, \\ [\eta] = [G]^\alpha [h]^\beta [c]^\gamma [k_B]^\delta = M^{-\alpha+\beta+\delta} L^{3\alpha+2\beta+\gamma+2\delta} T^{-2\alpha-\beta-\gamma-2\delta} K^{-\delta}, \end{cases} \quad (0.2)$$

Using the same scheme as above,

$$\Rightarrow \begin{cases} -\alpha + \beta + \delta = 1, \\ 3\alpha + 2\beta + \gamma + 2\delta = 0, \\ -2\alpha - \beta - \gamma - 2\delta = -2, \\ \delta = 1, \end{cases} \quad (\text{Each one (0.1)}) \Rightarrow \begin{cases} \alpha = -1, \\ \beta = -1, \\ \gamma = 3, \\ \delta = 1, \end{cases} \quad (\text{Each one (0.1)})$$

thus, $\eta = \frac{c^3 k_B}{G h}$. (0.1)

3.1)

The first law of thermodynamics is $dE = dQ + dW$. By assumption, $dW = 0$. Using the definition of entropy, $dS = \frac{dQ}{\theta}$, one obtains,

$$dE = \theta_H dS + 0, \quad (0.2) + (0.1), \text{ for setting } dW = 0.$$

$$\text{Using, } \begin{cases} S = \frac{Gk_B}{ch} m^2, & [(0.1) \text{ for } S] \\ E = mc^2, \end{cases}$$

$$\text{one obtains, } \theta_H = \frac{dE}{dS} = \left(\frac{dS}{dE} \right)^{-1} = c^2 \left(\frac{dS}{dm} \right)^{-1} \quad (0.2)$$

$$\text{Therefore, } \theta_H = \left(\frac{1}{2} \right) \frac{c^3 h}{Gk_B} \frac{1}{m}. \quad (0.1)+(0.1) \text{ (for the coefficient)}$$

3.2) The Stefan-Boltzmann's law gives the rate of energy radiation per unit area. Noting that $E = mc^2$ we have:

$$\begin{cases} dE / dt = -\sigma \theta_H^4 A, & (0.2) \\ \sigma = \frac{k_B^4}{c^2 h^3}, \\ A = \frac{m^2 G^2}{c^4} \\ E = mc^2. \end{cases} \Rightarrow c^2 \frac{dm}{dt} = -\frac{k_B^4}{c^2 h^3} \left(\frac{c^3 h}{2Gk_B} \frac{1}{m} \right)^4 \frac{m^2 G^2}{c^4}, \quad (0.2)$$

$$\Rightarrow \frac{dm}{dt} = -\frac{1}{16} \frac{c^4 h}{G^2} \frac{1}{m^2}. \quad (0.1) \text{ (for simplification)} + (0.2) \text{ (for the minus sign)}$$

3.3)

By integration:

$$\frac{dm}{dt} = -\frac{1}{16} \frac{c^4 h}{G^2} \frac{1}{m^2}. \Rightarrow \int m^2 dm = -\int \frac{c^4 h}{16G^2} dt \quad (0.3)$$

$$\Rightarrow m^3(t) - m^3(0) = -\frac{3c^4 h}{16G^2} t, \quad (0.2) + (0.2) \text{ (Integration and correct boundary values)}$$

At $t = t^*$ the black hole evaporates completely:

$$m(t^*) = 0 \quad (0.1) \Rightarrow t^* = \frac{16G^2}{3c^4 h} m^3 \quad (0.2)+(0.1) \text{ (for the coefficient)}$$

3.4) C_V measures the change in E with respect to variation of θ .

$$\begin{cases} C_V = \frac{dE}{d\theta}, & (0.2) \\ E = mc^2, & (0.2) \\ \theta = \frac{c^3 h}{2Gk_B} \frac{1}{m} \end{cases} \Rightarrow C_V = -\frac{2Gk_B}{ch} m^2. \quad (0.1)+(0.1) \text{ (for the coefficient)}$$

4.1) Again the Stefan-Boltzmann's law gives the rate of energy loss per unit area of the black hole. A similar relation can be used to obtain the energy gained by the black hole due to the background radiation. To justify it, note that in the thermal equilibrium, the total change in the energy is vanishing. The blackbody radiation is given by the Stefan-Boltzmann's law. Therefore the rate of energy gain is given by the same formula.

$$(0.1) + (0.4) \text{ (For the first and the second terms respectively)}$$

$$\begin{cases} \frac{dE}{dt} = -\sigma\theta^4 A + \sigma\theta_B^4 A \\ E = mc^2, \end{cases} \Rightarrow \frac{dm}{dt} = -\frac{hc^4}{16G^2} \frac{1}{m^2} + \frac{G^2}{c^8 h^3} (k_B \theta_B)^4 m^2 \quad (0.3)$$

4.2)

Setting $\frac{dm}{dt} = 0$, we have:

$$-\frac{hc^4}{16G^2} \frac{1}{m^{*2}} + \frac{G^2}{c^8 h^3} (k_B \theta_B)^4 m^{*2} = 0 \quad (0.2)$$

and consequently,

$$m^* = \frac{c^3 h}{2Gk_B} \frac{1}{\theta_B} \quad (0.2)$$

4.3)

$$\theta_B = \frac{c^3 h}{2Gk_B} \frac{1}{m^*} \Rightarrow \frac{dm}{dt} = -\frac{hc^4}{16G^2} \frac{1}{m^2} \left(1 - \frac{m^4}{m^{*4}}\right) \quad (0.2)$$

4.4) Use the solution to 4.2,

$$m^* = \frac{c^3 h}{2Gk_B} \frac{1}{\theta_B} \quad (0.2) \text{ and 3.1 to obtain, } \theta^* = \frac{c^3 h}{2Gk_B} \frac{1}{m^*} = \theta_B \quad (0.2)$$

One may also argue that m^* corresponds to thermal equilibrium. Thus for $m = m^*$ the black hole temperature equals θ_B .

Or one may set $\frac{dE}{dt} = -\sigma(\theta^{*4} - \theta_B^4)A = 0$ to get $\theta^* = \theta_B$.

4.5) Considering the solution to 4.3, one verifies that it will go away from the equilibrium. (0.6)

$$\frac{dm}{dt} = -\frac{hc^4}{G^2} \frac{1}{m^2} \left(1 - \frac{m^4}{m^{*4}} \right) \Rightarrow \begin{cases} m > m^* & \Rightarrow \frac{dm}{dt} > 0 \\ m < m^* & \Rightarrow \frac{dm}{dt} < 0 \end{cases}$$

Question “Pink”

1.1

$$\text{Period} = 3.0 \text{ days} = 2.6 \times 10^5 \text{ s} \quad (0.4)$$

$$\text{Period} = \frac{2\pi}{\omega} \quad (0.2) \Rightarrow \quad \omega = 2.4 \times 10^{-5} \text{ rad s}^{-1} \quad (0.2)$$

1.2

Calling the minima in the diagram 1, $I_1/I_0 = \alpha = 0.90$ and $I_2/I_0 = \beta = 0.63$, we have:

$$\frac{I_0}{I_1} = 1 + \left(\frac{R_2}{R_1}\right)^2 \left(\frac{T_2}{T_1}\right)^4 = \frac{1}{\alpha} \quad (0.4)$$

$$\frac{I_2}{I_1} = 1 - \left(\frac{R_2}{R_1}\right)^2 \left(1 - \left(\frac{T_2}{T_1}\right)^4\right) = \frac{\beta}{\alpha} \quad (0.4) \quad (\text{or equivalent relations})$$

From above, one finds:

$$\frac{R_1}{R_2} = \sqrt{\frac{\alpha}{1-\beta}} \Rightarrow \frac{R_1}{R_2} = 1.6 \quad (0.2+0.2) \quad \text{and} \quad \frac{T_1}{T_2} = \sqrt[4]{\frac{1-\beta}{1-\alpha}} \Rightarrow \frac{T_1}{T_2} = 1.4 \quad (0.2+0.2)$$

2.1)

Doppler-Shift formula:

$$\frac{\Delta\lambda}{\lambda_0} \cong \frac{v}{c} \quad (\text{or equivalent relation}) \quad (0.4)$$

$$\text{Maximum and minimum wavelengths: } \lambda_{1,\max} = 5897.7 \text{ \AA}, \lambda_{1,\min} = 5894.1 \text{ \AA} \\ \lambda_{2,\max} = 5899.0 \text{ \AA}, \lambda_{2,\min} = 5892.8 \text{ \AA}$$

Difference between maximum and minimum wavelengths:

$$\Delta\lambda_1 = 3.6 \text{ \AA}, \quad \Delta\lambda_2 = 6.2 \text{ \AA} \quad (\text{All } 0.6)$$

Using the Doppler relation and noting that the shift is due to twice the orbital speed: (Factor of two 0.4)

$$v_1 = c \frac{\Delta\lambda_1}{2\lambda_0} = 9.2 \times 10^4 \text{ m/s} \quad (0.2)$$

$$v_2 = c \frac{\Delta\lambda_2}{2\lambda_0} = 1.6 \times 10^5 \text{ m/s} \quad (0.2)$$

The student can use the wavelength of central line and maximum (or minimum) wavelengths. Marking scheme is given in the Excel file.

2.2) As the center of mass is not moving with respect to us: (0.5)

$$\frac{m_1}{m_2} = \frac{v_2}{v_1} = 1.7 \quad (0.2)$$

2.3)

Writing $r_i = \frac{v_i}{\omega}$ for $i = 1, 2$, we have (0.4)

$$r_1 = 3.8 \times 10^9 \text{ m}, \quad (0.2)$$

$$r_2 = 6.5 \times 10^9 \text{ m} \quad (0.2)$$

2.4)

$$r = r_1 + r_2 = 1.0 \times 10^{10} \text{ m} \quad (0.2)$$

3.1)

The gravitational force is equal to mass times the centrifugal acceleration

$$G \frac{m_1 m_2}{r^2} = m_1 \frac{v_1^2}{r_1} = m_2 \frac{v_2^2}{r_2} \quad (0.7)$$

Therefore,

$$\begin{cases} m_1 = \frac{r^2 v_2^2}{G r_2} \\ m_2 = \frac{r^2 v_1^2}{G r_1} \end{cases} \quad (0.1) \quad \Rightarrow \quad \begin{cases} m_1 = 6 \times 10^{30} \text{ kg} \\ m_2 = 3 \times 10^{30} \text{ kg} \end{cases} \quad (0.2 + 0.2)$$

4.1) As it is clear from the diagram, with one significant digit, $\alpha = 4$. (0.6)

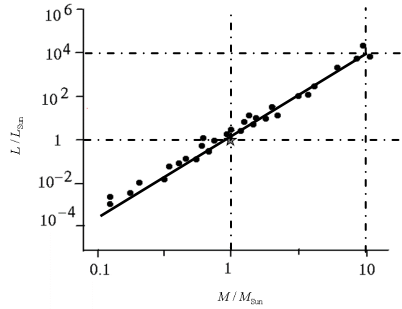

4.2)

As we have found in the previous section: $L_i = L_{Sun} \left(\frac{M_i}{M_{Sun}} \right)^4$ (0.2)

So,

$$L_1 = 3 \times 10^{28} \text{ Watt (0.2)}$$

$$L_2 = 4 \times 10^{27} \text{ Watt (0.2)}$$

4.3) The total power of the system is distributed on a sphere with radius d to produce I_0 , that is:

$$I_0 = \frac{L_1 + L_2}{4\pi d^2} \quad (0.5) \quad \Rightarrow d = \sqrt{\frac{L_1 + L_2}{4\pi I_0}} = 1 \times 10^{18} \text{ m} \quad (0.2)$$

$$= 100 \text{ ly. (0.2)}$$

4.4) $\theta \cong \tan \theta = \frac{r}{d} = 1 \times 10^{-8} \text{ rad. (0.2 + 0.2)}$

4.5)

A typical optical wavelength is λ_0 . Using uncertainty relation:

$$D = \frac{d \lambda_0}{r} \cong 50 \text{ m. (0.2 + 0.2)}$$

Solution (The Experimental Question):

Task 1

1a.

$$\Delta\theta_{\text{nominal}} = 5' = 0.08^\circ$$

$\Delta\theta_{\text{nominal}}$ (degree)	0.08
--	------

1b.

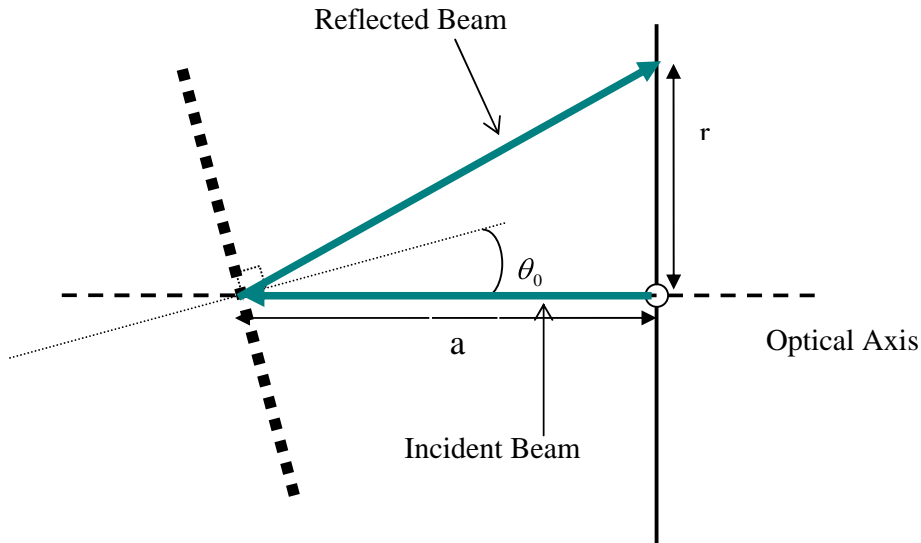

If “a” is the distance between card and the grating and “r” is the distance between the hole and the light spot so we have

$$\Delta f(x_1, x_2, \dots) = \sqrt{\left(\frac{\partial f}{\partial x_1} \Delta x_1\right)^2 + \left(\frac{\partial f}{\partial x_2} \Delta x_2\right)^2 + \dots}$$

$$\tan(2\theta_0) = \frac{r}{a}, \text{ If } \theta_0 \ll 1 \Rightarrow \theta_0 = \frac{r}{2a} \Rightarrow \Delta\theta_0 = \sqrt{\left(\frac{\Delta r}{2a}\right)^2 + \left(\frac{r \Delta a}{2a^2}\right)^2}$$

We want θ_0 to be zero i.e. $r = 0 \Rightarrow \Delta\theta_0 = \frac{\Delta r}{2a}$

$$\Delta r = 1\text{mm}, a = (70 \pm 1)\text{mm} \Rightarrow \theta_0 = \frac{\Delta r}{2a} \text{ rad} = 0.007 \text{ rad} = 0.4^\circ$$

$\Delta\theta_0$	0.4°
θ range of visible light (degree)	$13^\circ \leq \theta \leq 26^\circ$

1c.

$R_{\min}^{(0)}$	$(21.6 \pm 0.1) \text{ k}\Omega$
$\Delta\varphi_0$	$5' = 0.08^\circ$
$R_{\min}^{(1)}$	$R = (192 \pm 1) \text{ k}\Omega$

$\Delta\varphi_0 = 5'$ because

$$\theta = 5' \Rightarrow R = (21.9 \pm 0.1) \text{ k}\Omega$$

$$\theta = -5' \Rightarrow R = (21.9 \pm 0.1) \text{ k}\Omega$$

1d.

Table 1d. The measured parameters

θ (degree)	$R_{\text{glass}}(\text{M}\Omega)$	$\Delta R_{\text{glass}}(\text{M}\Omega)$	$R_{\text{film}}(\text{M}\Omega)$	$\Delta R_{\text{film}}(\text{M}\Omega)$
15.00	3.77	0.03	183	3
15.50	2.58	0.02	132	2
16.00	1.88	0.01	87	1
16.50	1.19	0.01	51.5	0.5
17.00	0.89	0.01	33.4	0.3
17.50	0.68	0.01	19.4	0.1
18.00	0.486	0.005	10.4	0.1
18.50	0.365	0.005	5.40	0.03
19.00	0.274	0.003	2.66	0.02
19.50	0.225	0.002	1.42	0.01
20.00	0.200	0.002	0.880	0.005
20.50	0.227	0.002	0.822	0.005
21.00	0.368	0.003	1.123	0.007
21.50	0.600	0.005	1.61	0.01
22.00	0.775	0.005	1.85	0.01
22.50	0.83	0.01	1.87	0.01
23.00	0.88	0.01	1.93	0.02
23.50	1.01	0.01	2.14	0.02
24.00	1.21	0.01	2.58	0.02
24.50	1.54	0.01	3.27	0.02
25.00	1.91	0.01	4.13	0.02
16.25	1.38	0.01	66.5	0.5
16.75	1.00	0.01	40.0	0.3
17.25	0.72	0.01	23.4	0.2
17.75	0.535	0.005	12.8	0.1
18.25	0.391	0.003	6.83	0.05
18.75	0.293	0.003	3.46	0.02
19.25	0.235	0.003	1.76	0.01
19.75	0.195	0.002	0.988	0.005
20.25	0.201	0.002	0.776	0.005
20.75	0.273	0.003	0.89	0.01

1e.

In $\theta = -20^\circ \Rightarrow R_{\text{glass}} = (132 \pm 2) \text{ k}\Omega$, $R_{\text{film}} = (518 \pm 5) \text{ k}\Omega$

θ	T_{film}	θ	T_{film}
$\theta = -20^\circ$	0.255	19.25	0.134
		19.50	0.158
		19.75	0.197
		20.00	0.227
		20.25	0.259
		20.50	0.276
		20.75	0.307

Graphics

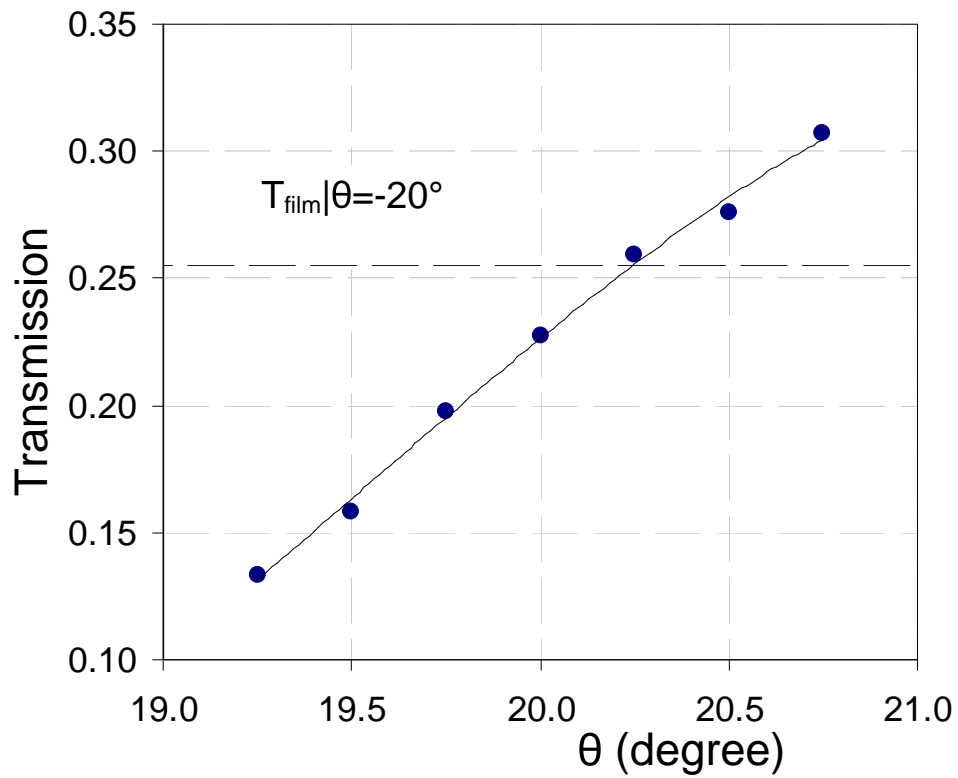

We see that: $T(\theta = 20.25^\circ) = T(\theta = -20^\circ)$

δ (degree)	0.25 ± 0.08
-------------------	-----------------

Task 2.

2a.

$$\lambda = d \sin\left(\theta - \frac{\delta}{2}\right) \Rightarrow \Delta\lambda = \lambda \sqrt{\left(\frac{\Delta d}{d}\right)^2 + \cot^2\left(\theta - \frac{\delta}{2}\right)\left(\Delta\theta^2 + \frac{\Delta\delta^2}{4}\right)} \approx d \cos(\theta) \left(\frac{0.1\pi}{180}\right)$$

where $\Delta\theta = \Delta\delta = 5' = 0.08$ degree

$$\text{and } d = \frac{1}{600} \text{ mm}$$

$$\Delta\lambda = 2.9 \cos(\theta) \text{ (nm)}$$

$$T_{film} = \frac{R_{glass}}{R_{film}} \Rightarrow \Delta T = T_{film} \sqrt{\left(\frac{\Delta R_{film}}{R_{film}}\right)^2 + \left(\frac{\Delta R_{glass}}{R_{glass}}\right)^2}$$

$$\Delta T = \frac{R_{glass}}{R_{film}} \sqrt{\left(\frac{\Delta R_{film}}{R_{film}}\right)^2 + \left(\frac{\Delta R_{glass}}{R_{glass}}\right)^2}$$

2b.

$$13 \leq \theta \leq 26$$

$$2.6 \leq \Delta\lambda \leq 2.8 \text{ nm}$$

2c.

Table 2c. The calculated parameters using the measured parameters

θ (degree)	λ (nm)	$I_g/C(\lambda)$ ($M\Omega^{-1}$)	$I_s/C(\lambda)$ ($M\Omega^{-1}$)	T_{film}	αt
15.0	428	0.265	0.00546	0.0206	3.88
15.5	442	0.388	0.00758	0.0195	3.94
16.0	456	0.532	0.0115	0.0216	3.83
16.25	463	0.725	0.0150	0.0208	3.88
16.5	470	0.840	0.0194	0.0231	3.77
16.75	477	1.00	0.0250	0.0250	3.69
17.0	484	1.12	0.0299	0.0266	3.63
17.25	491	1.39	0.0427	0.0308	3.48
17.5	498	1.47	0.0515	0.0351	3.35
17.75	505	1.87	0.0781	0.0418	3.17
18.0	512	2.06	0.096	0.0467	3.06
18.25	518	2.56	0.146	0.0572	2.86
18.5	525	2.74	0.185	0.0676	2.69
18.75	532	3.41	0.289	0.0847	2.47
19.0	539	3.65	0.376	0.103	2.27
19.25	546	4.26	0.568	0.134	2.01
19.5	553	4.44	0.704	0.158	1.84
19.75	560	5.13	1.01	0.197	1.62
20.0	567	5.00	1.14	0.227	1.48
20.25	573	4.98	1.29	0.259	1.35
20.5	580	4.41	1.22	0.276	1.29
20.75	587	3.66	1.12	0.307	1.18
21.0	594	2.72	0.890	0.328	1.12
21.5	607	1.67	0.621	0.373	0.99
22.0	621	1.29	0.541	0.419	0.87
22.5	634	1.20	0.535	0.444	0.81
23.0	648	1.14	0.518	0.456	0.79
23.5	661	0.99	0.467	0.472	0.75
24.0	675	0.826	0.388	0.469	0.76
24.5	688	0.649	0.306	0.471	0.75
25.0	701	0.524	0.242	0.462	0.77

2d.

Graphics

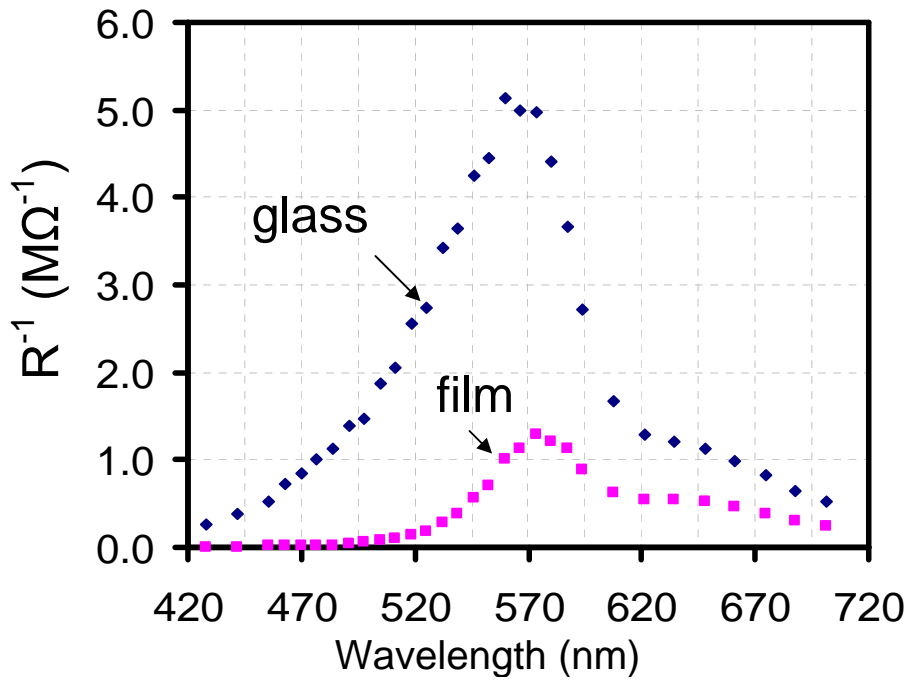

$\lambda_{\max}(I_{\text{glass}})$	564 ± 5 (nm)
$\lambda_{\max}(I_{\text{film}})$	573 ± 5 (nm)

2e. Graphics

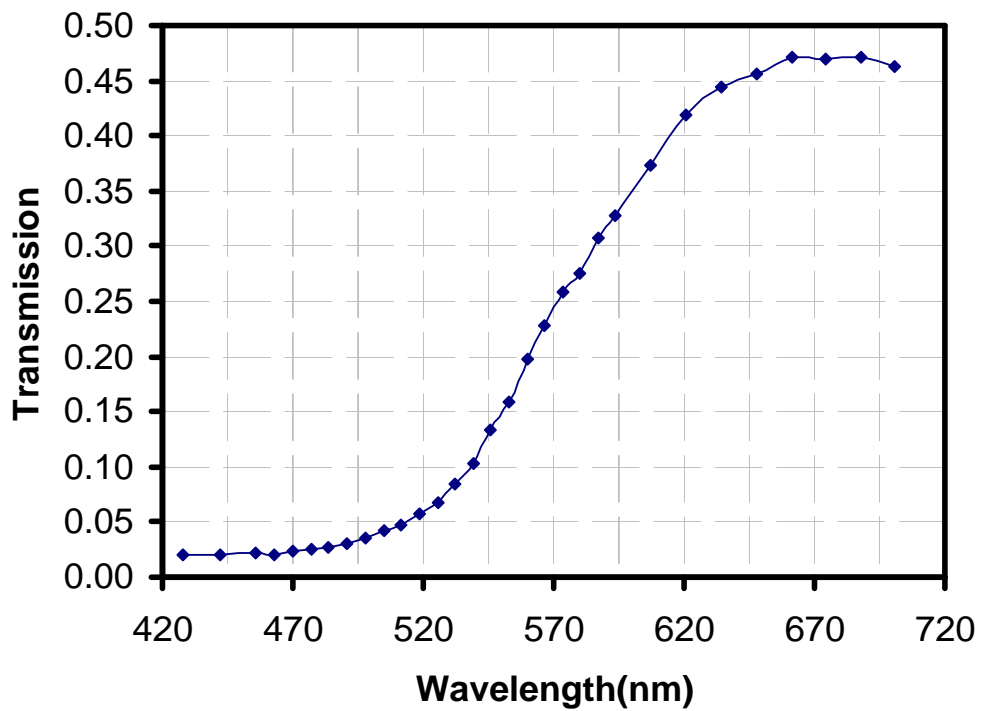

Task 3.

3a.

Table 3a. The calculated parameters for each measured data point

θ (degree)	x (eV)	y (eV ²)
15.00	2.898	126.6
15.50	2.806	121.9
16.00	2.720	108.8
16.25	2.679	107.8
16.50	2.639	98.9
16.75	2.600	92.0
17.00	2.563	86.3
17.25	2.527	77.4
17.50	2.491	69.7
17.75	2.457	60.9
18.00	2.424	55.1
18.25	2.392	46.8
18.50	2.360	40.4
18.75	2.330	33.1
19.00	2.300	27.3
19.25	2.271	20.91
19.50	2.243	17.07
19.75	2.215	12.92
20.00	2.188	10.51
20.25	2.162	8.53
20.50	2.137	7.56
20.75	2.112	6.23
21.00	2.088	5.43
21.50	2.041	4.06
22.00	1.997	3.02
22.50	1.954	2.52
23.00	1.914	2.26
23.50	1.875	1.98
24.00	1.838	1.94
24.50	1.803	1.84
25.00	1.769	1.86

3b.

Graphics

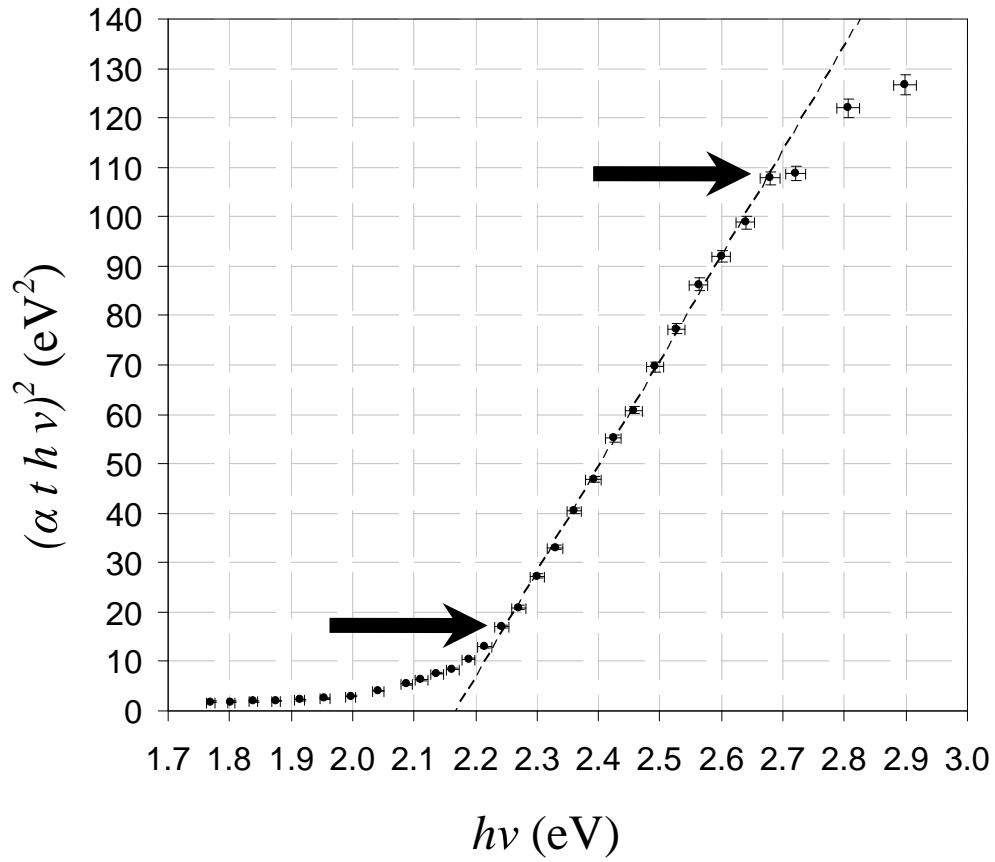

$$x_{\min} = 2.24(\text{eV})$$

$$x_{\max} = 2.68(\text{eV})$$

3c.

$$\alpha h\nu = A(h\nu - E_g)^{\frac{1}{2}} \Rightarrow (\alpha t h\nu)^2 = (At)^2(h\nu - E_g)$$

$$\Rightarrow y = (At)^2(x - E_g) \Rightarrow m = (At)^2 \Rightarrow t = \frac{\sqrt{m}}{A}$$

$$\Rightarrow \frac{\Delta t}{t} = \frac{\Delta m}{2m}$$

$$t = \frac{\sqrt{m}}{A}$$

$$\Delta t = \frac{\Delta m}{2A\sqrt{m}}$$

In linear range we have, $m=213$ (eV), $r^2=0.9986$, $E_g=2.17$ (eV)
and we have $A = 0.071$ (eV^{1/2}/nm) so we find $t= 206$ (nm)

$$\Delta m = \sqrt{\frac{(\delta y)^2 + \frac{m^2}{R^2}(\delta x)^2}{\sum_i x_i^2 - N\bar{x}^2}} \approx \sqrt{\frac{(\delta y)^2 + (m \delta x)^2}{\sum_i x_i^2 - N\bar{x}^2}} = \sqrt{\frac{(\delta \cdot xy)^2}{\sum_i x_i^2 - N\bar{x}^2}}, (\delta \cdot xy)^2 = (\delta y)^2 + (m \delta x)^2$$

where δx & δy are the mean of error range of x & y

$$\delta x \approx \sqrt{\frac{\sum_i \delta x_i^2}{N}} \text{ \& } \delta y = \sqrt{\frac{\sum_i \delta y_i^2}{N}} \text{ So } \delta x \approx 0.014 \text{ (eV)}, \delta y \approx 0.9 \text{ (eV)}^2$$

$$\rightarrow \Delta m \approx 10 \text{ (eV)} \rightarrow \Delta t = t \times \Delta m / (2 m) \approx 5 \text{ (nm)}$$

$$\Delta E_g = \frac{1}{m} \sqrt{\left(\left(\frac{m^2 \delta x^2 + \delta y^2}{N} \right) + \left(\frac{\bar{y}}{m} \right)^2 \Delta m^2 \right)} = \frac{1}{m} \sqrt{\left(\left(\frac{\delta xy^2}{N} \right) + \left(\frac{\bar{y}}{m} \right)^2 \Delta m^2 \right)}$$

$$\Delta E_g \approx 0.02 \text{ (eV)}$$

Table 3d. The calculated values of E_g and t using Fig. 3

E_g (eV)	ΔE_g (eV)	t (nm)	Δt (nm)
2.17	0.02	206	5

WATER-POWERED RICE-POUNDING MORTAR

A. Introduction

Rice is the main staple food of most people in Vietnam. To make white rice from paddy rice, one needs separate of the husk (a process called "hulling") and separate the bran layer ("milling"). The hilly parts of northern Vietnam are abundant with water streams, and people living there use *water-powered rice-pounding mortar* for bran layer separation. Figure 1 shows one of such mortars., Figure 2 shows how it works.

B. Design and operation

1. Design.

The rice-pounding mortar shown in Figure 1 has the following parts:

The mortar, basically a wooden container for rice.

The lever, which is a tree trunk with one larger end and one smaller end. It can rotate around a horizontal axis. A *pestle* is attached perpendicularly to the lever at the smaller end. The length of the pestle is such that it touches the rice in the mortar when the lever lies horizontally. The larger end of the lever is carved hollow to form a bucket. The shape of the bucket is crucial for the mortar's operation.

2. Modes of operation

The mortar has two modes.

Working mode. In this mode, the mortar goes through an operation cycle illustrated in Figure 2.

The rice-pounding function comes from the work that is transferred from the pestle to the rice during stage f) of Figure 2. If, for some reason, the pestle never touches the rice, we say that the mortar is not working.

Rest mode with the lever lifted up. During stage c) of the operation cycle (Figure 2), as the tilt angle α increases, the amount of water in the bucket decreases. At one particular moment in time, the amount of water is just enough to counterbalance the weight of the lever. Denote the tilting angle at this instant by β . If the lever is kept at angle β and the initial angular velocity is zero, then the lever will remain at this position forever. This is the rest mode with the lever lifted up. The stability of this position depends on the flow rate of water into the bucket, Φ . If Φ exceeds some value Φ_2 , then this rest mode is stable, and the mortar cannot be in the working mode.

In other words, Φ_2 is the minimal flow rate for the mortar not to work.



Figure 1

A water-powered rice-pounding mortar

OPERATION CYCLE OF A WATER-POWERED RICE-POUNDING MORTAR

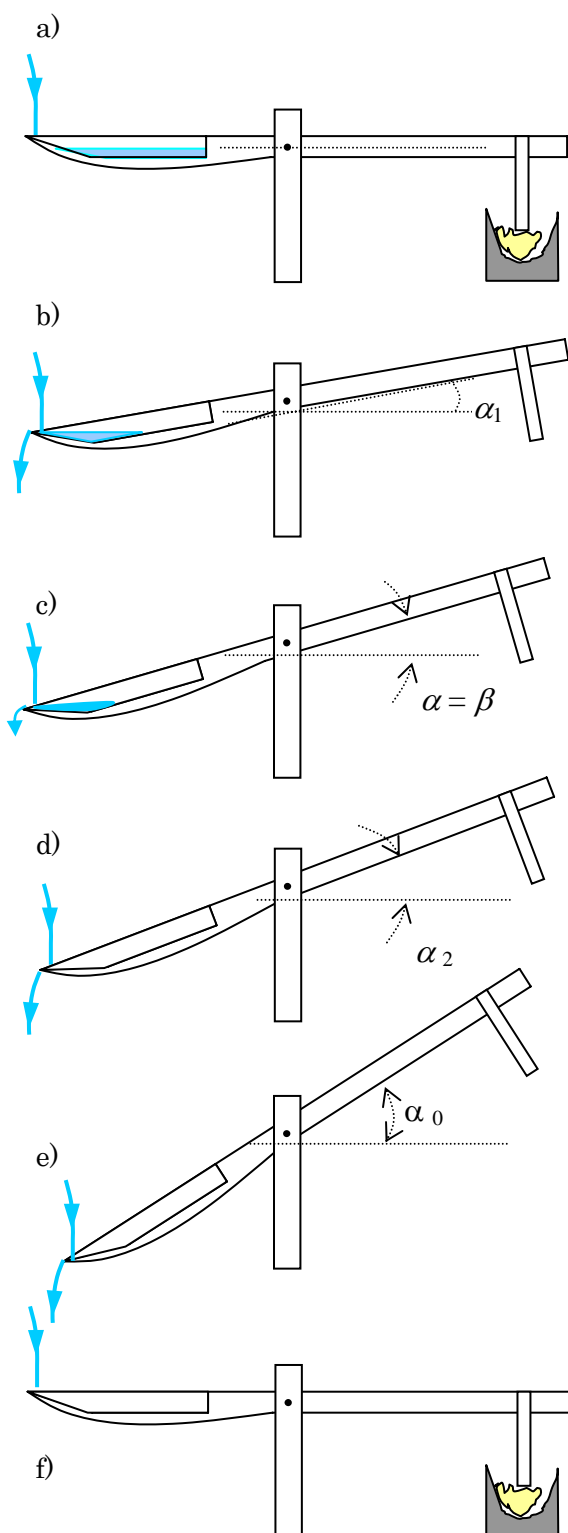
Figure 2

a) At the beginning there is no water in the bucket, the pestle rests on the mortar. Water flows into the bucket with a small rate, but for some time the lever remains in the horizontal position.

b) At some moment the amount of water is enough to lift the lever up. Due to the tilt, water rushes to the farther side of the bucket, tilting the lever more quickly.

Water starts to flow out at $\alpha = \alpha_1$.

c) As the angle α increases, water starts to flow out. At some particular tilt angle, $\alpha = \beta$, the total torque is zero.

d) α continues increasing, water continues to flow out until no water remains in the bucket.

e) α keeps increasing because of inertia. Due to the shape of the bucket, water falls into the bucket but immediately flows out. The inertial motion of the lever continues until α reaches the maximal value α_0 .

f) With no water in the bucket, the weight of the lever pulls it back to the initial horizontal position. The pestle gives the mortar (with rice inside) a pound and a new cycle begins.

C. The problem

Consider a water-powered rice-pounding mortar with the following parameters (Figure 3)

The mass of the lever (including the pestle but without water) is $M = 30$ kg,

The center of mass of the lever is G. The lever rotates around the axis T (projected onto the point T on the figure).

The moment of inertia of the lever around T is $I = 12 \text{ kg} \cdot \text{m}^2$.

When there is water in the bucket, the mass of water is denoted as m , the center of mass of the water body is denoted as N.

The tilt angle of the lever with respect to the horizontal axis is α .

The main length measurements of the mortar and the bucket are as in Figure 3.

Neglect friction at the rotation axis and the force due to water falling onto the bucket. In this problem, we make an approximation that the water surface is always horizontal.

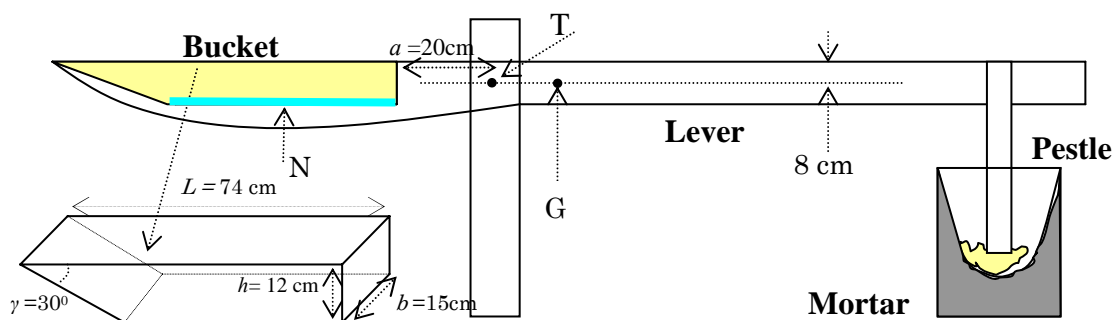

Figure 3 Design and dimensions of the rice-pounding mortar

1. The structure of the mortar

At the beginning, the bucket is empty, and the lever lies horizontally. Then water flows into the bucket until the lever starts rotating. The amount of water in the bucket at this moment is $m = 1.0$ kg.

1.1. Determine the distance from the center of mass G of the lever to the rotation axis T. It is known that GT is horizontal when the bucket is empty.

1.2. Water starts flowing out of the bucket when the angle between the lever and the horizontal axis reaches α_1 . The bucket is completely empty when this angle is α_2 .

Determine α_1 and α_2 .

1.3. Let $\mu(\alpha)$ be the total torque (relative to the axis T) which comes from the

weight of the lever and the water in the bucket. $\mu(\alpha)$ is zero when $\alpha = \beta$. Determine β and the mass m_1 of water in the bucket at this instant.

2. Parameters of the working mode

Let water flow into the bucket with a flow rate Φ which is constant and small. The amount of water flowing into the bucket when the lever is in motion is negligible. In this part, neglect the change of the moment of inertia during the working cycle.

2.1. Sketch a graph of the torque μ as a function of the angle α , $\mu(\alpha)$, during one operation cycle. Write down explicitly the values of $\mu(\alpha)$ at angle α_1 , α_2 , and $\alpha = 0$.

2.2. From the graph found in section 2.1., discuss and give the geometric interpretation of the value of the total energy W_{total} produced by $\mu(\alpha)$ and the work W_{pounding} that is transferred from the pestle to the rice.

2.3. From the graph representing μ versus α , estimate α_0 and W_{pounding} (assume the kinetic energy of water flowing into the bucket and out of the bucket is negligible.) You may replace curve lines by zigzag lines, if it simplifies the calculation.

3. The rest mode

Let water flow into the bucket with a constant rate Φ , but one cannot neglect the amount of water flowing into the bucket during the motion of the lever.

3.1. Assuming the bucket is always overflowed with water,

3.1.1. Sketch a graph of the torque μ as a function of the angle α in the vicinity of $\alpha = \beta$. To which kind of equilibrium does the position $\alpha = \beta$ of the lever belong?

3.1.2. Find the analytic form of the torque $\mu(\alpha)$ as a function of $\Delta\alpha$ when $\alpha = \beta + \Delta\alpha$, and $\Delta\alpha$ is small.

3.1.3. Write down the equation of motion of the lever, which moves with zero initial velocity from the position $\alpha = \beta + \Delta\alpha$ ($\Delta\alpha$ is small). Show that the motion is, with good accuracy, harmonic oscillation. Compute the period τ .

3.2. At a given Φ , the bucket is overflowed with water at all times only if the lever moves sufficiently slowly. There is an upper limit on the amplitude of harmonic oscillation, which depends on Φ . Determine the minimal value Φ_1 of Φ (in kg/s) so that the lever can make a harmonic oscillator motion with amplitude 1° .

3.3. Assume that Φ is sufficiently large so that during the free motion of the lever when the tilting angle decreases from α_2 to α_1 the bucket is always overflowed with water. However, if Φ is too large the mortar cannot operate. Assuming that the motion of the lever is that of a harmonic oscillator, estimate the minimal flow rate Φ_2 for the rice-pounding mortar to not work.

CHERENKOV LIGHT AND RING IMAGING COUNTER

Light propagates in vacuum with the speed c . There is no particle which moves with a speed higher than c . However, it is possible that in a transparent medium a particle moves with a speed v higher than the speed of the light in the same medium $\frac{c}{n}$, where n is the refraction index of the medium. Experiment (Cherenkov, 1934) and theory (Tamm and Frank, 1937) showed that a charged particle, moving with a speed v in a transparent medium with refractive index

n such that $v > \frac{c}{n}$, radiates light, called

Cherenkov light, in directions forming with the trajectory an angle

$$\theta = \arccos \frac{1}{\beta n} \quad (1)$$

where $\beta = \frac{v}{c}$.

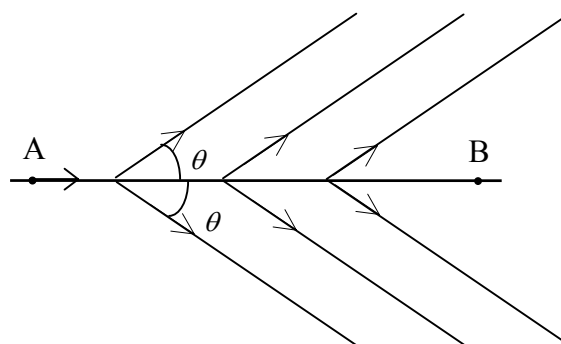

1. To establish this fact, consider a particle moving at constant velocity $v > \frac{c}{n}$ on a straight line. It passes A at time 0 and B at time t_1 . As the problem is symmetric with respect to rotations around AB, it is sufficient to consider light rays in a plane containing AB.

At any point C between A and B, the particle emits a spherical light wave, which propagates with velocity $\frac{c}{n}$. We define the wave front at a given time t as the envelope of all these spheres at this time.

1.1. Determine the wave front at time t_1 and draw its intersection with a plane containing the trajectory of the particle.

1.2. Express the angle φ between this intersection and the trajectory of the particle in terms of n and β .

2. Let us consider a beam of particles moving with velocity $v > \frac{c}{n}$, such that the angle θ is small, along a straight line IS. The beam crosses a concave spherical mirror of focal length f and center C, at point S. SC makes with SI a small angle α (see the figure in the Answer Sheet). The particle beam creates a ring image in the focal plane of the mirror.

Explain why with the help of a sketch illustrating this fact. Give the position of the center O and the radius r of the ring image.

This set up is used in *ring imaging Cherenkov counters* (RICH) and the medium which the particle traverses is called the *radiator*.

Note: in all questions of the present problem, terms of second order and higher in α and θ will be neglected.

3. A beam of particles of known momentum $p = 10.0 \text{ GeV}/c$ consists of three types of particles: protons, kaons and pions, with rest mass $M_p = 0.94 \text{ GeV}/c^2$,

$M_k = 0.50 \text{ GeV}/c^2$ and $M_\pi = 0.14 \text{ GeV}/c^2$, respectively. Remember that pc and Mc^2 have the dimension of an energy, and 1 eV is the energy acquired by an electron after being accelerated by a voltage 1 V , and $1 \text{ GeV} = 10^9 \text{ eV}$, $1 \text{ MeV} = 10^6 \text{ eV}$.

The particle beam traverses an air medium (the radiator) under the pressure P . The refraction index of air depends on the air pressure P according to the relation $n = 1 + aP$ where $a = 2.7 \times 10^{-4} \text{ atm}^{-1}$

3.1. Calculate for each of the three particle types the minimal value P_{\min} of the air pressure such that they emit Cherenkov light.

3.2. Calculate the pressure $P_{\frac{1}{2}}$ such that the ring image of kaons has a radius equal to one half of that corresponding to pions. Calculate the values of θ_k and θ_π in this case.

Is it possible to observe the ring image of protons under this pressure?

4. Assume now that the beam is not perfectly monochromatic: the particles momenta are distributed over an interval centered at $10 \text{ GeV}/c$ having a half width at half height Δp . This makes the ring image broaden, correspondingly θ distribution has a half width at half height $\Delta\theta$. The pressure of the radiator is $P_{\frac{1}{2}}$ determined in 3.2.

4.1. Calculate $\frac{\Delta\theta_k}{\Delta p}$ and $\frac{\Delta\theta_\pi}{\Delta p}$, the values taken by $\frac{\Delta\theta}{\Delta p}$ in the pions and kaons cases.

4.2. When the separation between the two ring images, $\theta_\pi - \theta_k$, is greater than 10

times the half-width sum $\Delta\theta = \Delta\theta_{\kappa} + \Delta\theta_{\pi}$, that is $\theta_{\pi} - \theta_{\kappa} > 10 \Delta\theta$, it is possible to distinguish well the two ring images. Calculate the maximal value of Δp such that the two ring images can still be well distinguished.

5. Cherenkov first discovered the effect bearing his name when he was observing a bottle of water located near a radioactive source. He saw that the water in the bottle emitted light.

5.1. Find out the minimal kinetic energy T_{\min} of a particle with a rest mass M moving in water, such that it emits Cherenkov light. The index of refraction of water is $n = 1.33$.

5.2. The radioactive source used by Cherenkov emits either α particles (i.e. helium nuclei) having a rest mass $M_{\alpha} = 3.8 \text{ GeV}/c^2$ or β particles (i.e. electrons) having a rest mass $M_e = 0.51 \text{ MeV}/c^2$. Calculate the numerical values of T_{\min} for α particles and β particles.

Knowing that the kinetic energy of particles emitted by radioactive sources never exceeds a few MeV, find out which particles give rise to the radiation observed by Cherenkov.

6. In the previous sections of the problem, the dependence of the Cherenkov effect on wavelength λ has been ignored. We now take into account the fact that the Cherenkov radiation of a particle has a broad continuous spectrum including the visible range (wavelengths from $0.4 \mu\text{m}$ to $0.8 \mu\text{m}$). We know also that the index of refraction n of the radiator decreases linearly by 2% of $n - 1$ when λ increases over this range.

6.1. Consider a beam of pions with definite momentum of $10.0 \text{ GeV}/c$ moving in air at pressure 6 atm. Find out the angular difference $\delta\theta$ associated with the two ends of the visible range.

6.2. On this basis, study qualitatively the effect of the dispersion on the ring image of pions with momentum distributed over an interval centered at $p = 10 \text{ GeV}/c$ and having a half width at half height $\Delta p = 0.3 \text{ GeV}/c$.

6.2.1. Calculate the broadening due to dispersion (varying refraction index) and that due to achromaticity of the beam (varying momentum).

6.2.2. Describe how the color of the ring changes when going from its inner to outer edges by checking the appropriate boxes in the Answer Sheet.

CHANGE OF AIR TEMPERATURE WITH ALTITUDE, ATMOSPHERIC STABILITY AND AIR POLLUTION

Vertical motion of air governs many atmospheric processes, such as the formation of clouds and precipitation and the dispersal of air pollutants. If the atmosphere is *stable*, vertical motion is restricted and air pollutants tend to be accumulated around the emission site rather than dispersed and diluted. Meanwhile, in an *unstable* atmosphere, vertical motion of air encourages the vertical dispersal of air pollutants. Therefore, the pollutants' concentrations depend not only on the strength of emission sources but also on the *stability* of the atmosphere.

We shall determine the atmospheric stability by using the concept of *air parcel* in meteorology and compare the temperature of the air parcel rising or sinking adiabatically in the atmosphere to that of the surrounding air. We will see that in many cases an air parcel containing air pollutants and rising from the ground will come to rest at a certain altitude, called a *mixing height*. The greater the mixing height, the lower the air pollutant concentration. We will evaluate the mixing height and the concentration of carbon monoxide emitted by motorbikes in the Hanoi metropolitan area for a morning rush hour scenario, in which the vertical mixing is restricted due to a temperature inversion (air temperature increases with altitude) at elevations above 119 m.

Let us consider the air as an ideal diatomic gas, with molar mass $\mu = 29$ g/mol.

Quasi equilibrium adiabatic transformation obey the equation $pV^\gamma = \text{const}$, where

$\gamma = \frac{c_p}{c_v}$ is the ratio between isobaric and isochoric heat capacities of the gas.

The student may use the following data if necessary:

The universal gas constant is $R = 8.31$ J/(mol.K).

The atmospheric pressure on ground is $p_0 = 101.3$ kPa

The acceleration due to gravity is constant, $g = 9.81$ m/s²

The molar isobaric heat capacity is $c_p = \frac{7}{2}R$ for air.

The molar isochoric heat capacity is $c_v = \frac{5}{2}R$ for air.

Mathematical hints

a.
$$\int \frac{dx}{A+Bx} = \frac{1}{B} \int \frac{d(A+Bx)}{A+Bx} = \frac{1}{B} \ln(A+Bx)$$

b. The solution of the differential equation $\frac{dx}{dt} + Ax = B$ (with A and B constant) is

$$x(t) = x_1(t) + \frac{B}{A} \text{ where } x_1(t) \text{ is the solution of the differential equation } \frac{dx}{dt} + Ax = 0.$$

c.
$$\lim_{x \rightarrow \infty} \left(1 + \frac{1}{x}\right)^x = e$$

1. Change of pressure with altitude.1.1. Assume that the temperature of the atmosphere is uniform and equal to T_0 .Write down the expression giving the atmospheric pressure p as a function of the altitude z .

1.2. Assume that the temperature of the atmosphere varies with the altitude according to the relation

$$T(z) = T(0) - \Lambda z$$

where Λ is a constant, called the *temperature lapse rate* of the atmosphere (the vertical gradient of temperature is $-\Lambda$).1.2.1. Write down the expression giving the atmospheric pressure p as a function of the altitude z .1.2.2. A process called free convection occurs when the air density increases with altitude. At which values of Λ does the free convection occur?**2. Change of the temperature of an air parcel in vertical motion**

Consider an air parcel moving upward and downward in the atmosphere. An air parcel is a body of air of sufficient dimension, several meters across, to be treated as an independent thermodynamical entity, yet small enough for its temperature to be considered uniform. The vertical motion of an air parcel can be treated as a quasi adiabatic process, i.e. the exchange of heat with the surrounding air is negligible. If the air parcel rises in the atmosphere, it expands and cools. Conversely, if it moves downward, the increasing outside pressure will compress the air inside the parcel and its temperature will increase.

As the size of the parcel is not large, the atmospheric pressure at different points on

the parcel boundary can be considered to have the same value $p(z)$, with z - the altitude of the parcel center. The temperature in the parcel is uniform and equals to $T_{\text{parcel}}(z)$, which is generally different from the temperature of the surrounding air $T(z)$. In parts 2.1 and 2.2, we do not make any assumption about the form of $T(z)$.

2.1. The change of the parcel temperature T_{parcel} with altitude is defined by

$$\frac{dT_{\text{parcel}}}{dz} = -G. \text{ Derive the expression of } G(T, T_{\text{parcel}}).$$

2.2. Consider a special atmospheric condition in which at any altitude z the temperature T of the atmosphere equals to that of the parcel T_{parcel} , $T(z) = T_{\text{parcel}}(z)$.

We use Γ to denote the value of G when $T = T_{\text{parcel}}$, that is $\Gamma = -\frac{dT_{\text{parcel}}}{dz}$

(with $T = T_{\text{parcel}}$). Γ is called *dry adiabatic lapse rate*.

2.2.1. Derive the expression of Γ

2.2.2. Calculate the numerical value of Γ .

2.2.3. Derive the expression of the atmospheric temperature $T(z)$ as a function of the altitude.

2.3. Assume that the atmospheric temperature depends on altitude according to the relation $T(z) = T(0) - \Lambda z$, where Λ is a constant. Find the dependence of the parcel temperature $T_{\text{parcel}}(z)$ on altitude z .

2.4. Write down the approximate expression of $T_{\text{parcel}}(z)$ when $|\Lambda z| \ll T(0)$ and $T(0) \approx T_{\text{parcel}}(0)$.

3. The atmospheric stability.

In this part, we assume that T changes linearly with altitude.

3.1. Consider an air parcel initially in equilibrium with its surrounding air at altitude

z_0 , i.e. it has the same temperature $T(z_0)$ as that of the surrounding air. If the parcel is moved slightly up and down (e.g. by atmospheric turbulence), one of the three following cases may occur:

- The air parcel finds its way back to the original altitude z_0 , the equilibrium of the parcel is stable. The atmosphere is said to be stable.

- The parcel keeps moving in the original direction, the equilibrium of the parcel is unstable. The atmosphere is unstable.

- The air parcel remains at its new position, the equilibrium of the parcel is indifferent. The atmosphere is said to be neutral.

What is the condition on Λ for the atmosphere to be stable, unstable or neutral?

3.2. A parcel has its temperature on ground $T_{\text{parcel}}(0)$ higher than the temperature $T(0)$ of the surrounding air. The buoyancy force will make the parcel rise. Derive the expression for the maximal altitude the parcel can reach in the case of a stable atmosphere in terms of Λ and Γ .

4. The mixing height

4.1. Table 1 shows air temperatures recorded by a radio sounding balloon at 7:00 am on a November day in Hanoi. The change of temperature with altitude can be approximately described by the formula $T(z) = T(0) - \Lambda z$ with different lapse rates Λ in the three layers $0 < z < 96$ m, $96 \text{ m} < z < 119$ m and $119 \text{ m} < z < 215$ m.

Consider an air parcel with temperature $T_{\text{parcel}}(0) = 22^\circ\text{C}$ ascending from ground. On the basis of the data given in Table 1 and using the above linear approximation, calculate the temperature of the parcel at the altitudes of 96 m and 119 m.

4.2. Determine the maximal elevation H the parcel can reach, and the temperature $T_{\text{parcel}}(H)$ of the parcel.

H is called the mixing height. Air pollutants emitted from ground can mix with the air in the atmosphere (e.g. by wind, turbulence and dispersion) and become diluted within this layer.

Table 1

Data recorded by a radio sounding balloon at 7:00 am on a November day in Hanoi.

Altitude, m	Temperature, °C
5	21.5
60	20.6
64	20.5
69	20.5
75	20.4
81	20.3
90	20.2
96	20.1
102	20.1
109	20.1
113	20.1
119	20.1
128	20.2
136	20.3
145	20.4
153	20.5
159	20.6
168	20.8
178	21.0
189	21.5
202	21.8
215	22.0
225	22.1
234	22.2
246	22.3
257	22.3

5. Estimation of carbon monoxide (CO) pollution during a morning motorbike rush hour in Hanoi.

Hanoi metropolitan area can be approximated by a rectangle with base dimensions L and W as shown in the figure, with one side taken along the south-west bank of the Red River.

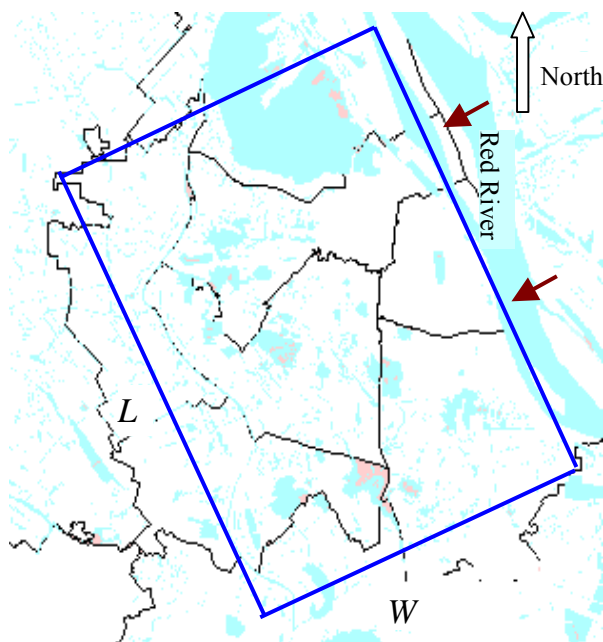

It is estimated that during the morning rush hour, from 7:00 am to 8:00 am, there are 8×10^5 motorbikes on the road, each running on average 5 km and emitting 12 g of CO per kilometer. The amount of CO pollutant is approximately considered as emitted uniformly in time, at a constant rate M during the rush hour. At the same time, the clean north-east wind blows perpendicularly to the Red River (i.e. perpendicularly to the sides L of the rectangle) with velocity u , passes the city with the same velocity, and carries a part of the CO-polluted air out of the city atmosphere.

Also, we use the following rough approximate model:

- The CO spreads quickly throughout the entire volume of the mixing layer above the Hanoi metropolitan area, so that the concentration $C(t)$ of CO at time t can be assumed to be constant throughout that rectangular box of dimensions L , W and H .

- The upwind air entering the box is clean and no pollution is assumed to be lost from the box through the sides parallel to the wind.

- Before 7:00 am, the CO concentration in the atmosphere is negligible.

5.1. Derive the differential equation determining the CO pollutant concentration $C(t)$ as a function of time.

5.2. Write down the solution of that equation for $C(t)$.

5.3. Calculate the numerical value of the concentration $C(t)$ at 8:00 a.m.

Given $L = 15$ km, $W = 8$ km, $u = 1$ m/s.

DIFFERENTIAL THERMOMETRIC METHOD

In this problem, we use the differential thermometric method to fulfill the two following tasks:

1. Finding the temperature of solidification of a crystalline solid substance.
2. Determining the efficiency of a solar cell.

A. Differential thermometric method

In this experiment forward biased silicon diodes are used as temperature sensors to measure temperature. If the electric current through the diode is constant, then the voltage drop across the diode depends on the temperature according to the relation

$$V(T) = V(T_0) - \alpha(T - T_0) \quad (1)$$

where $V(T)$ and $V(T_0)$ are respectively the voltage drops across the diode at temperature T and at room temperature T_0 (measured in $^{\circ}\text{C}$), and the factor

$$\alpha = (2.00 \pm 0.03) \text{ mV}/^{\circ}\text{C} \quad (2)$$

The value of $V(T_0)$ may vary slightly from diode to diode.

If two such diodes are placed at different temperatures, the difference between the temperatures can be measured from the difference of the voltage drops across the two diodes. The difference of the voltage drops, called the *differential voltage*, can be measured with high precision; hence the temperature difference can also be measured with high precision. This method is called the *differential thermometric method*. The electric circuit used with the diodes in this experiment is shown in Figure 1. Diodes D_1 and D_2 are forward biased by a 9V battery, through $10 \text{ k}\Omega$ resistors, R_1 and R_2 . This circuit keeps the current in the two diodes approximately constant.

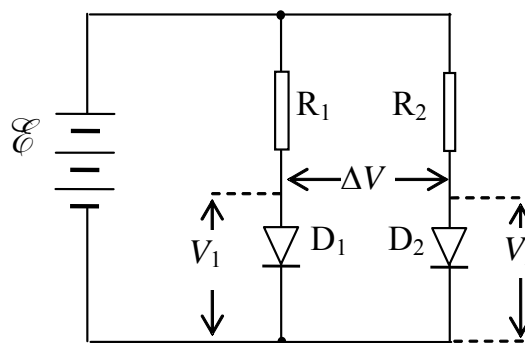

Figure 1. Electric circuit of the diode

If the temperature of diode D_1 is T_1 and that of D_2 is T_2 , then according to (1), we have:

$$V_1(T_1) = V_1(T_0) - \alpha(T_1 - T_0)$$

and

$$V_2(T_2) = V_2(T_0) - \alpha(T_2 - T_0)$$

The differential voltage is:

$$\Delta V = V_2(T_2) - V_1(T_1) = V_2(T_0) - V_1(T_0) - \alpha(T_2 - T_1) = \Delta V(T_0) - \alpha(T_2 - T_1)$$

$$\Delta V = \Delta V(T_0) - \alpha \Delta T \tag{3}$$

in which $\Delta T = T_2 - T_1$. By measuring the differential voltage ΔV , we can determine the temperature difference.

To bias the diodes, we use a circuit box, the diagram of which is shown in Figure 2.

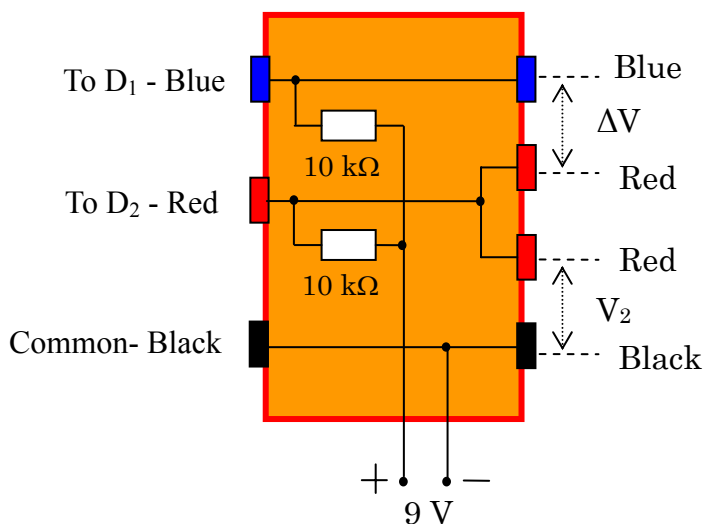

Figure 2. Diagram of the circuit box
(top view)

The circuit box contains two biasing resistors of $10\text{ k}\Omega$ for the diodes, electrical leads to the 9 V battery, sockets for connecting to the diodes D_1 and D_2 , and sockets for connecting to digital multimeters to measure the voltage drop V_2 on diode D_2 and the differential voltage ΔV of the diodes D_1 and D_2 .

B. Task 1: Finding the temperature of solidification of a crystalline substance**1. Aim of the experiment**

If a crystalline solid substance is heated to the melting state and then cooled down, it solidifies at a fixed temperature T_s , called *temperature of solidification*, also called the *melting point* of the substance. The *traditional method* to determine T_s is to follow the change in temperature with time during the cooling process. Due to the fact that the solidification process is accompanied by the release of the latent heat of the phase transition, the temperature of the substance does not change while the substance is solidifying. If the amount of the substance is large enough, the time interval in which the temperature remains constant is rather long, and one can easily determine this temperature. On the contrary, if the amount of substance is small, this time interval is too short to be observed and hence it is difficult to determine T_s .

In order to determine T_s in case of small amount of substance, we use the *differential thermometric method*, whose principle can be summarized as follows. We use two identical small dishes, one containing a small amount of the substance to be studied, called the *sample dish*, and the other not containing the substance, called the *reference dish*. The two dishes are put on a heat source, whose temperature varies slowly with time. The thermal flows to and from the two dishes are nearly the same. Each dish contains a temperature sensor (a forward biased silicon diode). While there is no phase change in the substance, the temperature T_{samp} of the sample dish and the temperature T_{ref} of the reference dish vary at nearly the same rate, and thus $\Delta T = T_{\text{ref}} - T_{\text{samp}}$ varies slowly with T_{samp} . If there is a phase change in the substance, and during the phase change T_{samp} does not vary and equals T_s , while T_{ref} steadily varies, then ΔT varies quickly. The plot of ΔT versus T_{samp} shows an abrupt change. The value of T_{samp} corresponding to the abrupt change of ΔT is indeed T_s .

The aim of this experiment is to determine the temperature of solidification T_s of a

pure crystalline substance, having T_s in the range from 50°C to 70°C , by using the traditional and differential thermal analysis methods. The amount of substance used in the experiment is about 20 mg.

2. Apparatus and materials

1. The heat source is a 20 W halogen lamp.
2. The dish holder is a bakelite plate with a square hole in it. A steel plate is fixed on the hole. Two small magnets are put on the steel plate.
3. Two small steel dishes, each contains a silicon diode soldered on it. One dish is used as the reference dish, the other - as the sample dish.

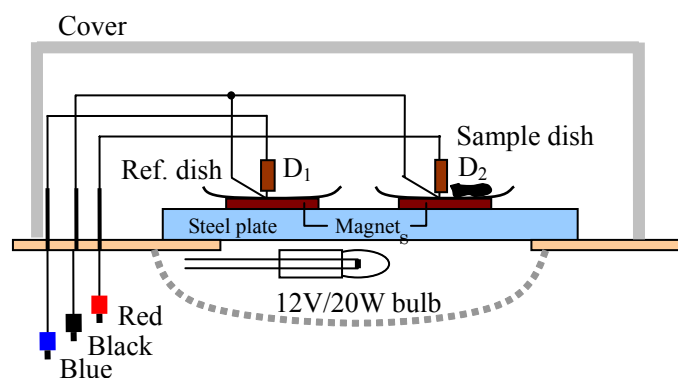

Figure 3. Apparatus for measuring the solidification temperature

Each dish is placed on a magnet. The magnetic force maintains the contact between the dish, the magnet and the steel plate. The magnets also keep a moderate thermal contact between the steel plate and the dishes.

A grey plastic box used as a cover to protect the dishes from the outside influence.

Figure 3 shows the arrangement of the dishes and the magnets on the dish holder and the light bulb.

4. Two digital multimeters are used as voltmeters. They can also measure room temperature by turning the Function selector to the “ $^\circ\text{C}/^\circ\text{F}$ ” function. The voltage function of the multimeter has an error of ± 2 on the last digit.

Note: to prevent the multimeter (see Figure 9) from going into the “Auto power

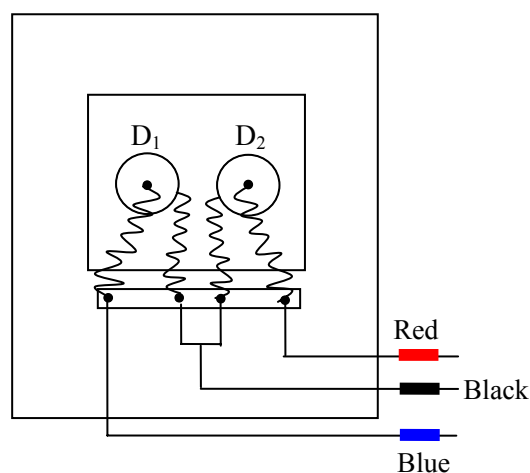

Figure 4. The dishes on the dish holder (top view)

off" function, turn the Function selector from OFF position to the desired function while pressing and holding the SELECT button.

5. A circuit box as shown in Figure 2.
6. A 9 V battery.
7. Electrical leads.
8. A small ampoule containing about 20 mg of the substance to be measured.
9. A stop watch
10. A calculator
11. Graph papers.

3. Experiment

1. The magnets are placed on two equivalent locations on the steel plate. The reference dish and the empty sample dish are put on the magnets as shown in the Figure 4. We use the dish on the left side as the reference dish, with diode D_1 on it (D_1 is called the reference diode), and the dish on the right side as the sample dish, with diode D_2 on it (D_2 is called the measuring diode).

Put the lamp-shade up side down as shown in Figure 5. Do not switch the lamp on. Put the dish holder on the lamp. Connect the apparatuses so that you can measure the voltage drop on the diode D_2 , that is $V_{\text{samp}} = V_2$, and the differential voltage ΔV .

In order to eliminate errors due to the warming up period of the instruments and devices, it is strongly recommended that the complete measurement circuit be switched on for about 5 minutes before starting real experiments.

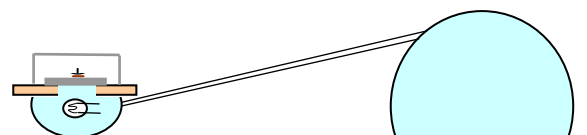

Figure 5.

Using the halogen lamp as a heat source

1.1. Measure the room temperature T_0 and the voltage drop $V_{\text{samp}}(T_0)$ across diode D_2 fixed to the sample dish, at room temperature T_0 .

1.2. Calculate the voltage drops $V_{\text{samp}}(50^\circ\text{C})$, $V_{\text{samp}}(70^\circ\text{C})$ and $V_{\text{samp}}(80^\circ\text{C})$ on the measuring diode at temperatures 50°C , 70°C and 80°C , respectively.

Experimental Problem

2. With both dishes still empty, switch the lamp on. Follow V_{samp} . When the temperature of the sample dish reaches $T_{\text{samp}} \sim 80^{\circ}\text{C}$, switch the lamp off.

2.1. Wait until $T_{\text{samp}} \sim 70^{\circ}\text{C}$, and then follow the change in V_{samp} and ΔV with time, while the steel plate is cooling down. Note down the values of V_{samp} and ΔV every 10 s to 20 s in the table provided in the answer sheet. If ΔV varies quickly, the time interval between consecutive measurements may be shorter. When the temperature of the sample dish decreases to $T_{\text{samp}} \sim 50^{\circ}\text{C}$, the measurement is stopped.

2.2. Plot the graph of V_{samp} versus t , called Graph 1, on a graph paper provided.

2.3. Plot the graph of ΔV versus V_{samp} , called Graph 2, on a graph paper provided.

Note: for 2.2 and 2.3 do not forget to write down the correct name of each graph.

3. Pour the substance from the ampoule into the sample dish. Repeat the experiment identically as mentioned in section 2.

3.1. Write down the data of V_{samp} and ΔV with time t in the table provided in the answer sheet.

3.2. Plot the graph of V_{samp} versus t , called Graph 3, on a graph paper provided.

3.3. Plot the graph of ΔV versus V_{samp} , called Graph 4, on a graph paper provided.

Note: for 3.2 and 3.3 do not forget to write down the correct name of each graph.

4. By comparing the graphs in section 2 and section 3, determine the temperature of solidification of the substance.

4.1. Using the traditional method to determine T_s : by comparing the graphs of V_{samp} versus t in sections 3 and 2, i.e. Graph 3 and Graph 1, mark the point on Graph 3 where the substance solidifies and determine the value V_s (corresponding to this point) of V_{samp} .

Find out the temperature of solidification T_s of the substance and estimate its error.

4.2. Using the differential thermometric method to determine T_s : by comparing the graphs of ΔV versus V_{samp} in sections 3 and 2, i.e. Graph 4 and Graph 2, mark the point on Graph 4 where the substance solidifies and determine the value V_s of V_{samp} .

Find out the temperature of solidification T_s of the substance.

4.3. From errors of measurement data and instruments, calculate the error of T_s obtained with the differential thermometric method. Write down the error calculations and finally write down the values of T_s together with its error in the answer sheet.

C. Task 2: Determining the efficiency of a solar cell under illumination of an incandescent lamp

1. Aim of the experiment

The aim of the experiment is to determine the *efficiency* of a solar cell under illumination of an incandescent lamp. Efficiency is defined as the ratio of the electrical power that the solar cell can supply to an external circuit, to the total radiant power received by the cell. The efficiency depends on the incident radiation spectrum. In this experiment the radiation incident to the cell is that of an incandescent halogen lamp. In order to determine the efficiency of the solar cell, we have to measure the *irradiance* E at a point situated under the lamp, at a distance d from the lamp along the vertical direction, and the *maximum power* P_{max} of the solar cell when it is placed at this point. In this experiment, $d = 12$ cm (Figure 6). Irradiance E can be defined by:

$$E = \Phi / S$$

in which Φ is the radiant flux (radiant power), and S is the area of the illuminated surface.

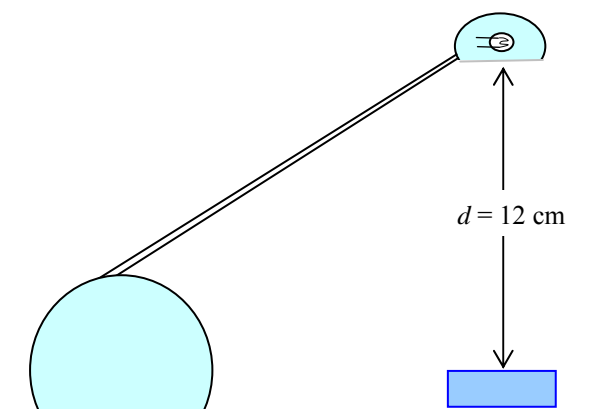

Figure 6.

Using the halogen lamp
as a light source

2. Apparatus and materials

1. The light source is a 20W halogen lamp.
2. The radiation detector is a hollow cone made of copper, the inner surface of it is blackened with soot (Figure 7). The cone is incompletely thermally isolated from the surrounding. In this experiment, the detector is considered an ideal black body. To measure temperature, we use silicon diodes. The measuring diode is fixed to the radiation detector (D_2 in Figure 1 and Figure 7), so that its temperature equals that of the cone. The reference diode is placed on the inner side of the wall of the box containing the detector; its temperature equals that of the surrounding. The total heat capacity of the detector (the cone and the measuring diode) is $C = (0.69 \pm 0.02) \text{ J/K}$. The detector is covered by a very thin polyethylene film; the radiation absorption and reflection of which can be neglected.

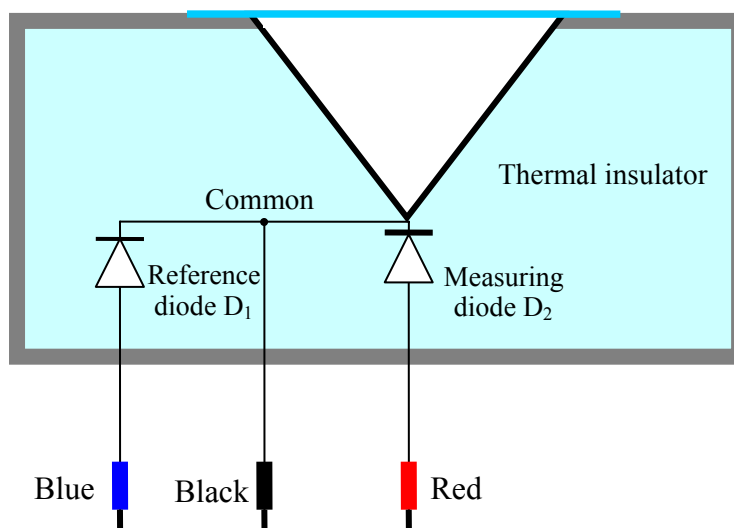

Figure 7. Diagram of the radiation detector

3. A circuit box as shown in Figure 2.
4. A piece of solar cell fixed on a plastic box (Figure 8). The area of the cell includes some metal connection strips. For the efficiency calculation these strips are considered parts of the cell.
5. Two digital multimeters. When used to measure the voltage, they have a very large internal resistance, which can be considered infinitely large. When we use them to measure the current, we cannot neglect their internal resistance. The voltage function of the multimeter has an error of ± 2 on the last digit.

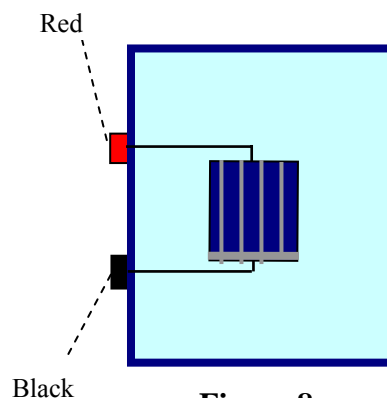

Figure 8.
The solar cell

The multimeters can also measure the room temperature.

Note: to prevent the multimeter (see Figure 9) from going into the “Auto power off” function, turn the Function selector from OFF position to the desired function while pressing and holding the SELECT button.

6. A 9 V battery
7. A variable resistor.
8. A stop watch
9. A ruler with 1mm divisions
10. Electrical leads.
11. Graph papers.

3. Experiment

When the detector receives energy from radiation, it heats up. At the same time, the detector loses its heat by several mechanisms, such as thermal conduction, convection, radiation etc...Thus, the radiant energy received by detector in a time interval dt is equal to the sum of the energy needed to increase the detector temperature and the energy transferred from the detector to the surrounding:

$$\Phi dt = CdT + dQ$$

where C is the heat capacity of the detector and the diode, dT - the temperature increase and dQ - the heat loss.

When the temperature difference between the detector and the surrounding $\Delta T = T - T_0$ is small, we can consider that the heat dQ transferred from the detector to the surrounding in the time interval dt is approximately proportional to ΔT and dt , that is $dQ = k\Delta T dt$, with k being a factor having the dimension of W/K. Hence, assuming that k is constant and ΔT is small, we have:

$$\Phi dt = CdT + k\Delta T dt = Cd(\Delta T) + k\Delta T dt$$

$$\text{or } \frac{d(\Delta T)}{dt} + \frac{k}{C}\Delta T = \frac{\Phi}{C} \quad (4)$$

The solution of this differential equation determines the variation of the temperature difference ΔT with time t , from the moment the detector begins to receive the light with a constant irradiation, assuming that at $t=0$, $\Delta T = 0$

$$\Delta T(t) = \frac{\Phi}{k} \left(1 - e^{-\frac{k}{C}t} \right) \quad (5)$$

When the radiation is switched off, the mentioned above differential equation becomes

Experimental Problem

$$\frac{d(\Delta T)}{dt} + \frac{k}{C} \Delta T = 0 \quad (6)$$

and the temperature difference ΔT varies with the time according to the following formula:

$$\Delta T (t) = \Delta T (0) e^{-\frac{k}{C} t} \quad (7)$$

where $\Delta T(0)$ is the temperature difference at $t = 0$ (the moment when the measurement starts).

1. Determine the room temperature T_0 .

2. Compose an electric circuit comprising the diode sensors, the circuit box and the multimeters to measure the temperature of the detector.

In order to eliminate errors due to the warming up period of the instruments and devices, it is strongly recommended that the complete measurement circuit be switched on for about 5 minutes before starting real experiments.

2.1. Place the detector under the light source, at a distance of $d = 12$ cm to the lamp. The lamp is off. Follow the variation of ΔV for about 2 minutes with sampling intervals of 10 s and determine the value of $\Delta V(T_0)$ in equation (3).

2.2. Switch the lamp on to illuminate the detector. Follow the variation of ΔV . Every 10-15 s, write down a value of ΔV in the table provided in the answer sheet. (Note: columns x and y of the table will be used later in section 4.). After 2 minutes, switch the lamp off.

2.3. Move the detector away from the lamp. Follow the variation of ΔV for about 2 minutes after that. Every 10-15 s, write down a value of ΔV in the table provided in the answer sheet. (Note: columns x and y of the table will be used later in section 3.).

Hints: As the detector has a thermal inertia, it is recommended not to use some data obtained immediately after the moment the detector begins to be illuminated or ceases to be illuminated.

3. Plot a graph in an x - y system of coordinates, with variables x and y chosen appropriately, in order to prove that after the lamp is switched off, equation (7) is satisfied.

3.1. Write down the expression for variables x and y .

3.2. Plot a graph of y versus x , called Graph 5.

3.3. From the graph, determine the value of k .

4. Plot a graph in an x - y system of coordinates, with variables x and y chosen

Experimental Problem

appropriately, in order to prove that when the detector is illuminated, equation (5) is satisfied.

- 4.1. Write down the expressions for variables x and y .
- 4.2. Plot a graph of y versus x , called Graph 6.
- 4.3. Determine the irradiance E at the orifice of the detector.

5. Put the solar cell to the same place where the radiation detector was. Connect the solar cell to an appropriate electric circuit comprising the multimeters and a variable resistor which is used to change the load of the cell. Measure the current in the circuit and the voltage on the cell at different values of the resistor.

- 5.1. Draw a diagram of the circuit used in this experiment.
- 5.2. By rotating the knob of the variable resistor, you change the value of the load. Note the values of current I and voltage V at each position of the knob.
- 5.3. Plot a graph of the power of the cell, which supplies to the load, as a function of the current through the cell. This is Graph 7.
- 5.4. From the graph deduce the maximum power P_{\max} of the cell and estimate its error.
- 5.5. Write down the expression for the efficiency of the cell that corresponds to the obtained maximum power. Calculate its value and error.

Contents of the experiment kit (see also Figure 10)

1	Halogen lamp 220 V/ 20 W	9	Stop watch
2	Dish holder	10	Calculator
3	Dish	11	Radiation detector
4	Multimeter	12	Solar cell
5	Circuit box	13	Variable resistor
6	9 V battery	14	Ruler
7	Electrical leads	15	Box used as a cover
8	Ampoule with substance to be measured		

Note: to prevent the multimeter (see Figure 9) from going into the “Auto power off” function, turn the Function selector from OFF position to the desired function while pressing and holding the SELECT button.

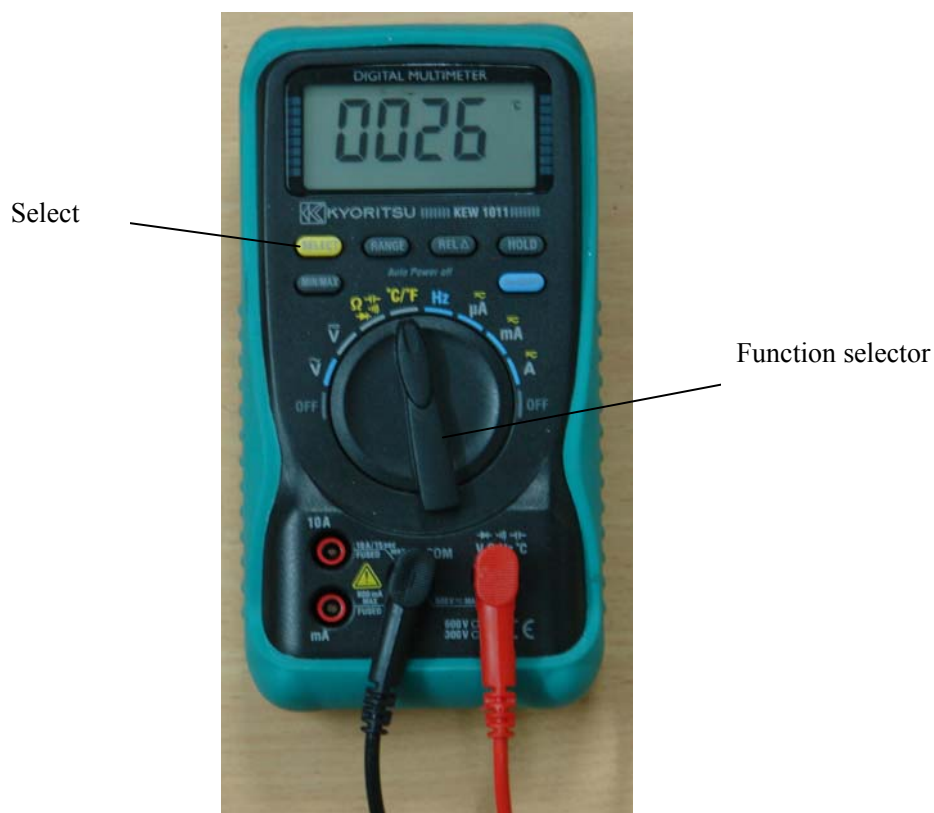

Figure 9. Digital multimeter

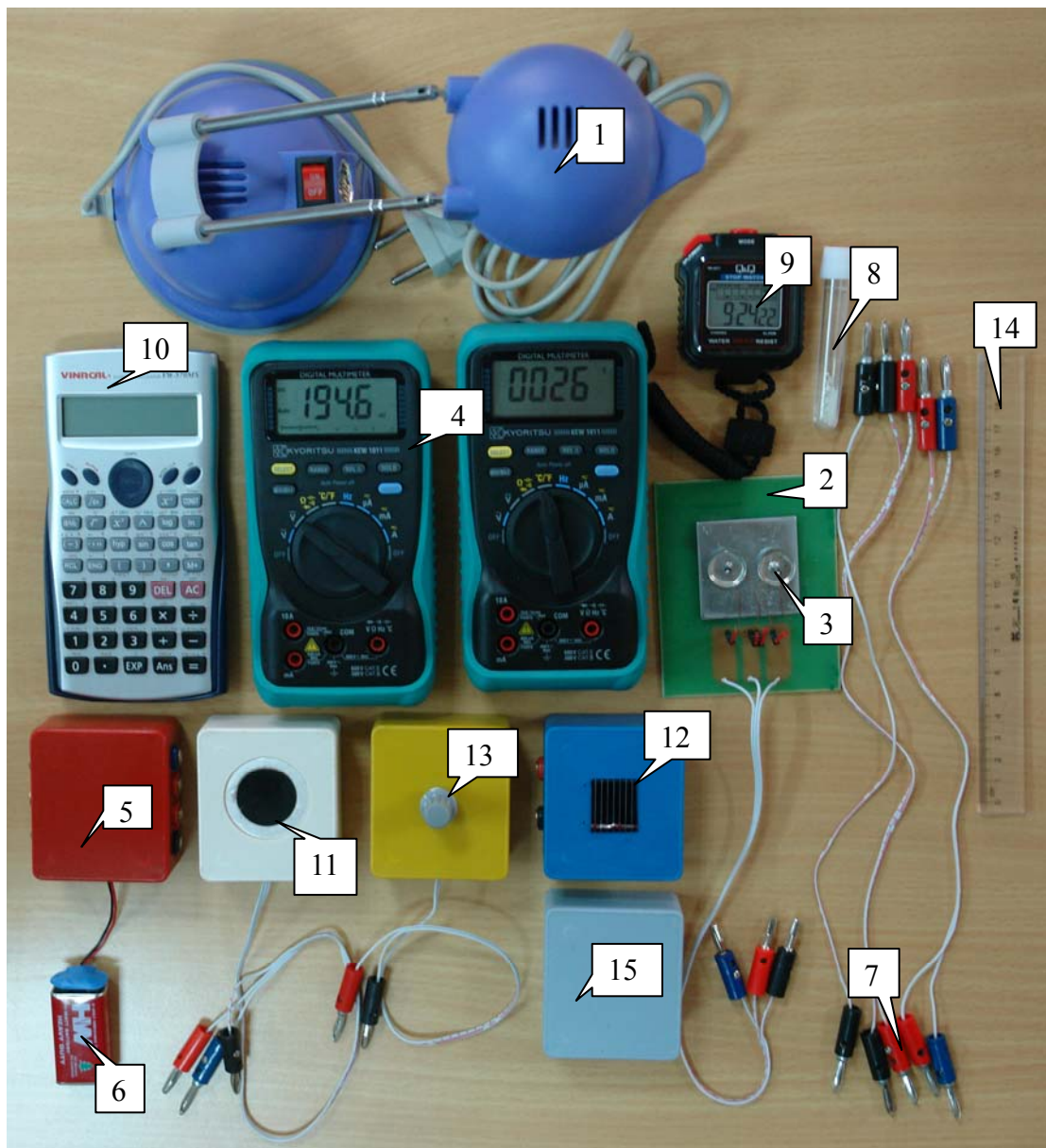

Figure 10. Contents of the experiment kit

Solution

1. The structure of the mortar

1.1. Calculating the distance TG

The volume of water in the bucket is $V = 1000 \text{ cm}^3 = 10^{-3} \text{ m}^3$. The length of the bottom of the bucket is $d = L - h \tan 60^\circ = (0.74 - 0.12 \tan 60^\circ) \text{ m} = 0.5322 \text{ m}$.

(as the initial data are given with two significant digits, we shall keep only two significant digits in the final answer, but we keep more digits in the intermediate steps).

The height c of the water layer in the bucket is calculated from the formula:

$$V = bcd + b \frac{c}{2} c \tan 60^\circ \Rightarrow c = \frac{(d^2 + 2\sqrt{3}V/b)^{1/2} - d}{\sqrt{3}}$$

Inserting numerical values for V , b and d , we find $c = 0.01228 \text{ m}$.

When the lever lies horizontally, the distance, on the horizontal axis, between the rotation axis and the center of mass of water N, is $\text{TH} \approx a + \frac{d}{2} + \frac{c}{4} \tan 60^\circ = 0.4714 \text{ m}$, and $\text{TG} = (m/M) \text{TH} = 0.01571 \text{ m}$ (see the figure below).

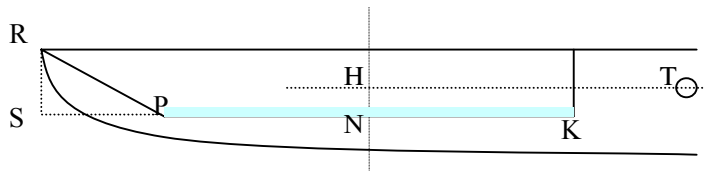

Answer: $\text{TG} = 0.016 \text{ m}$.

1.2. Calculating the values of α_1 and α_2 .

When the lever tilts with angle α_1 , water level is at the edge of the bucket. At that point the water volume is 10^{-3} m^3 . Assume $\text{PQ} < d$. From geometry $V = hb \times \text{PQ} / 2$, from which $\text{PQ} = 0.1111 \text{ m}$. The assumption $\text{PQ} < d$ is obviously satisfied ($d = 0.5322 \text{ m}$).

To compute the angle α_1 , we note that $\tan \alpha_1 = h / \text{QS} = h / (\text{PQ} + \sqrt{3}h)$. From this we find $\alpha_1 = 20.6^\circ$.

When the tilt angle is 30° , the bucket is empty: $\alpha_2 = 30^\circ$.

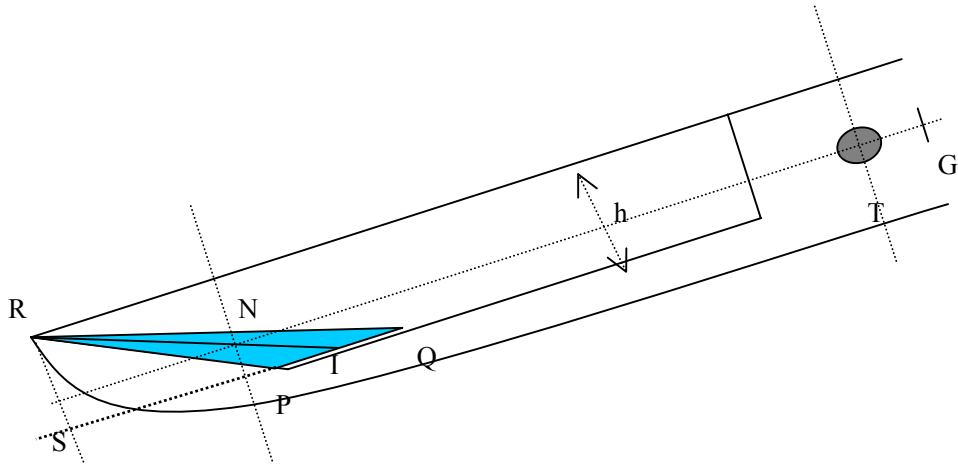

1.3. Determining the tilt angle β of the lever and the amount of water in the bucket m when the total torque μ on the lever is equal to zero

Denote $PQ = x(\text{m})$. The amount of water in the bucket is

$$m = \rho_{\text{water}} \frac{xhb}{2} = 9x \text{ (kg)}.$$

$\mu = 0$ when the torque coming from the water in the bucket cancels out the torque coming from the weight of the lever. The cross section of the water in the bucket is the triangle PQR in the figure. The center of mass N of water is located at $2/3$ of the meridian RI, therefore NTG lies on a straight line. Then: $mg \times TN = Mg \times TG$ or

$$m \times TN = M \times TG = 30 \times 0.1571 = 0.4714 \quad (1)$$

Calculating TN from x then substitute (1):

$$TN = L + a - \frac{2}{3}(h\sqrt{3} + \frac{x}{2}) = 0.94 - 0.08\sqrt{3} - \frac{x}{3} = 0.8014 - \frac{x}{3}$$

$$\text{which implies } m \times TN = 9x(0.8014 - x/3) = -3x^2 + 7.213x \quad (2)$$

So we find an equation for x :

$$-3x^2 + 7.213x = 0.4714 \quad (3)$$

The solutions to (3) are $x = 2.337$ and $x = 0.06723$. Since x has to be smaller than 0.5322 , we have to take $x = x_0 = 0.06723$ and $m = 9x_0 = 0.6051\text{kg}$.

$$\tan \beta = \frac{h}{x + h\sqrt{3}} = 0.4362, \text{ or } \beta = 23.57^\circ.$$

Answer: $m = 0.61\text{kg}$ and $\beta = 23.6^\circ$.

2. Parameters of the working mode

2.1. Graphs of $\mu(\alpha)$, $\alpha(t)$, and $\mu(t)$ during one operation cycle.

Initially when there is no water in the bucket, $\alpha = 0$, μ has the largest magnitude equal to $gM \times TG = 30 \times 9.81 \times 0.01571 = 4.624 \text{ N} \cdot \text{m}$. Our convention will be that the sign of this torque is negative as it tends to decrease α .

As water flows into the bucket, the torque coming from the water (which carries positive sign) makes μ increase until μ is slightly positive, when the lever starts to lift up. From that moment, by assumption, the amount of water in the bucket is constant.

The lever tilts so the center of mass of water moves away from the rotation axis, leading to an increase of μ , which reaches maximum when water is just about to overflow the edge of the bucket. At this moment $\alpha = \alpha_1 = 20.6^\circ$.

A simple calculation shows that

$$SI = SP + PQ/2 = 0.12 \times 1.732 + 0.1111/2 = 0.2634 \text{ m}.$$

$$TN = 0.20 + 0.74 - \frac{2}{3}SI = 0.7644 \text{ m}.$$

$$\mu_{\max} = (1.0 \times TN - 30 \times TG)g \cos 20.6^\circ$$

$$= (1.0 \times 0.7644 - 30 \times 0.01571) \times 9.81 \times \cos 20.6^\circ = 2.690 \text{ N} \cdot \text{m}.$$

Therefore $\mu_{\max} = 2.7 \text{ N} \cdot \text{m}$.

As the bucket tilts further, the amount of water in the bucket decreases, and when $\alpha = \beta$, $\mu = 0$. Due to inertia, α keeps increasing and μ keeps decreasing. The bucket is empty when $\alpha = 30^\circ$, when μ equals $-30 \times g \times TG \times \cos 30^\circ = -4.0 \text{ N} \cdot \text{m}$. After that α keeps increasing due to inertia to α_0 ($\mu = -gM TG \cos \alpha_0 = -4.62 \cos \alpha_0 \text{ N} \cdot \text{m}$), then quickly decreases to 0 ($\mu = -4.62 \text{ N} \cdot \text{m}$).

On this basis we can sketch the graphs of $\alpha(t)$, $\mu(t)$, and $\mu(\alpha)$ as in the figure below

Theoretical Problem No. 1 /Solution

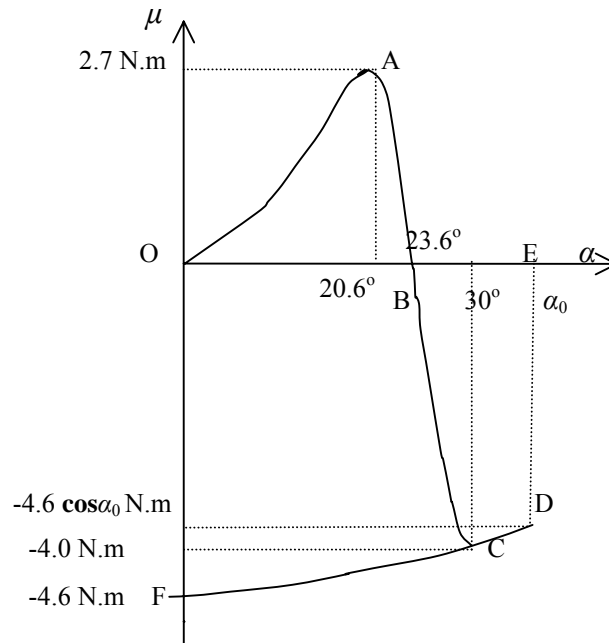

2.2. The infinitesimal work produced by the torque $\mu(\alpha)$ is $dW = \mu(\alpha)d\alpha$. The energy obtained by the lever during one cycle due to the action of $\mu(\alpha)$ is $W = \oint \mu(\alpha)d\alpha$, which is the area limited by the line $\mu(\alpha)$. Therefore W_{total} is equal to the area enclosed by the curve (OABCDFO) on the graph $\mu(\alpha)$.

The work that the lever transfers to the mortar is the energy the lever receives as it moves from the position $\alpha = \alpha_0$ to the horizontal position $\alpha = 0$. We have W_{pounding} equals to the area of (OEDFO) on the graph $\mu(\alpha)$. It is equal to $gM \times TG \times \sin \alpha_0 = 4.6 \sin \alpha_0$ (J).

2.3. The magnitudes of α_0 can be estimated from the fact that at point D the energy of the lever is zero. We have

$$\text{area (OABO)} = \text{area (BEDCB)}$$

Approximating OABO by a triangle, and BEDCB by a trapezoid, we obtain:

$$23.6 \times 2.7 \times (1/2) = 4.0 \times [(\alpha_0 - 23.6) + (\alpha_0 - 30)] \times (1/2),$$

which implies $\alpha_0 = 34.7^\circ$. From this we find

$$W_{\text{pounding}} = \text{area (OEDFO)} = \int_{34.76}^0 -Mg \times TG \times \cos \alpha d\alpha = 4.62 \times \sin 34.7^\circ = 2.63$$

Thus we find $W_{\text{pounding}} \approx 2.6 \text{ J}$.

3. The rest mode

3.1.

3.1.1. The bucket is always overflow with water. The two branches of $\mu(\alpha)$ in the vicinity of $\alpha = \beta$ corresponding to increasing and decreasing α coincide with each other.

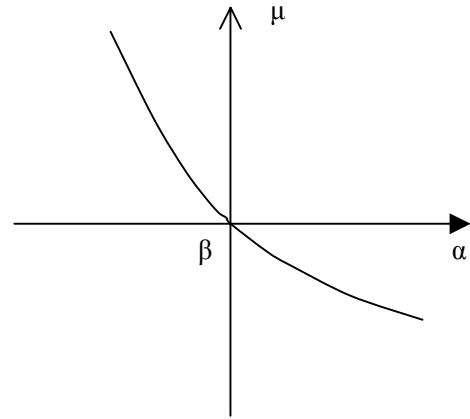

The graph implies that $\alpha = \beta$ is a stable equilibrium of the mortar.

3.1.2. Find the expression for the torque μ when the tilt angle is $\alpha = \beta + \Delta\alpha$ ($\Delta\alpha$ is small).

The mass of water in bucket when the lever tilts with angle α is $m = (1/2)\rho b h PQ$, where $PQ = h\left(\frac{1}{\tan\alpha} - \frac{1}{\tan 30^\circ}\right)$. A simple calculation shows that when α increases from β to $\beta + \Delta\alpha$, the mass of water increases by

$$\Delta m = -\frac{bh^2\rho}{2\sin^2\alpha}\Delta\alpha \approx -\frac{bh^2\rho}{2\sin^2\beta}\Delta\alpha.$$

The torque μ acting on the lever when the tilt is $\beta + \Delta\alpha$ equals the torque due to Δm .

We have $\mu = \Delta m \times g \times TN \times \cos(\beta + \Delta\alpha)$. TN is found from the equilibrium condition of the lever at tilting angle β :

$$TN = M \times TG / m = 30 \times 0.01571 / 0.605 = 0.779 \text{ m}.$$

We find at the end $\mu = -47.2 \times \Delta\alpha \text{ N} \cdot \text{m} \approx -47 \times \Delta\alpha \text{ N} \cdot \text{m}$.

3.1.3. Equation of motion of the lever

$$\mu = I \frac{d^2\alpha}{dt^2} \text{ where } \mu = -47 \times \Delta\alpha, \alpha = \beta + \Delta\alpha, \text{ and } I \text{ is the sum of moments}$$

of inertia of the lever and of the water in bucket relative to the axis T. Here I is not constant the amount of water in the bucket depends on α . When $\Delta\alpha$ is small, one can consider the amount and the shape of water in the bucket to be constant, so I is approximate a constant. Consider water in bucket as a material point with mass 0.6 kg, a simple calculation gives $I = 12 + 0.6 \times 0.78^2 = 12.36 \approx 12.4 \text{ kg m}^2$. We have

$$-47 \times \Delta\alpha = 12.4 \times \frac{d^2\Delta\alpha}{dt^2}.$$

That is the equation for a harmonic oscillator with period

$$\tau = 2\pi\sqrt{\frac{12.4}{47}} = 3.227. \text{ The answer is therefore } \tau = 3.2 \text{ s.}$$

3.2. Harmonic oscillation of lever (around $\alpha = \beta$) when bucket is always overflown. Assume the lever oscillate harmonically with amplitude $\Delta\alpha_0$ around $\alpha = \beta$. At time $t = 0$, $\Delta\alpha = 0$, the bucket is overflown. At time dt the tilt changes by $d\alpha$. We are interested in the case $d\alpha < 0$, i.e., the motion of lever is in the direction of decreasing α , and one needs to add more water to overflow the bucket. The equation of motion is:

$$\Delta\alpha = -\Delta\alpha_0 \sin(2\pi t / \tau), \text{ therefore } d(\Delta\alpha) = d\alpha = -\Delta\alpha_0 (2\pi / \tau) \cos(2\pi t / \tau) dt.$$

For the bucket to be overflown, during this time the amount of water falling to the bucket should be at least $dm = -\frac{bh^2\rho}{2\sin^2\beta} d\alpha = \frac{2\Delta\alpha_0\pi bh^2\rho dt}{2\tau\sin^2\beta} \cos\left(\frac{2\pi t}{\tau}\right)$; dm is

$$\text{maximum at } t = 0, \quad dm_0 = \frac{\pi bh^2\rho\Delta\alpha_0}{\tau\sin^2\beta} dt.$$

The amount of water falling to the bucket is related to flow rate Φ ; $dm_0 = \Phi dt$,

$$\text{therefore } \Phi = \frac{\pi bh^2\rho\Delta\alpha_0}{\tau\sin^2\beta}.$$

An overflown bucket is the necessary condition for harmonic oscillations of the lever, therefore the condition for the lever to have harmonic oscillations with amplitude 1° or $2\pi/360$ rad is $\Phi \geq \Phi_1$ with

$$\Phi_1 = \frac{\pi bh^2\rho 2\pi}{360\tau\sin^2\beta} = 0.2309 \text{ kg/s}$$

$$\text{So } \Phi_1 = 0.23 \text{ kg/s.}$$

3.3 Determination of Φ_2

If the bucket remains overflown when the tilt decreases to 20.6° , then the amount of water in bucket should reach 1 kg at this time, and the lever oscillate harmonically with amplitude equal $23.6^\circ - 20.6^\circ = 3^\circ$. The flow should exceed $3\Phi_1$, therefore

$$\Phi_2 = 3 \times 0.23 \approx 0.7 \text{ kg/s.}$$

This is the minimal flow rate for the rice-pounding mortar not to work.

Solution

1.

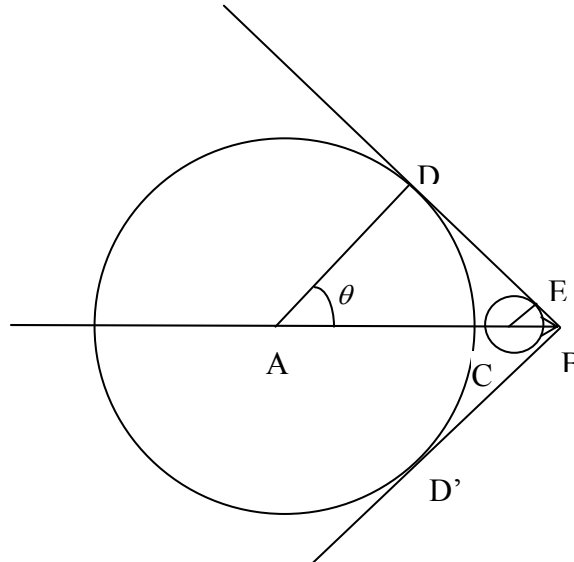

Figure 1

Let us consider a plane containing the particle trajectory. At $t = 0$, the particle position is at point A. It reaches point B at $t = t_1$. According to the Huygens principle, at moment $0 < t < t_1$, the radiation emitted at A reaches the circle with a radius equal to AD and the one emitted at C reaches the circle of radius CE. The radii of the spheres are proportional to the distance of their centre to B:

$$\frac{CE}{CB} = \frac{c(t_1 - t)/n}{v(t_1 - t)} = \frac{1}{\beta n} = \text{const}$$

The spheres are therefore transformed into each other by homothety of vertex B and their envelope is the cone of summit B and half aperture $\varphi = \text{Arcsin} \frac{1}{\beta n} = \frac{\pi}{2} - \theta$, where θ is the angle made by the light ray CE with the particle trajectory.

1.1. The intersection of the wave front with the plane is two straight lines, BD and BD'.

1.2. They make an angle $\varphi = \text{Arcsin} \frac{1}{\beta n}$ with the particle trajectory.

2. The construction for finding the ring image of the particles beam is taken in the plane containing the trajectory of the particle and the optical axis of the mirror.

We adopt the notations:

S – the point where the beam crosses the spherical mirror

F – the focus of the spherical mirror

C – the center of the spherical mirror

IS – the straight-line trajectory of the charged particle making a small angle α with the optical axis of the mirror.

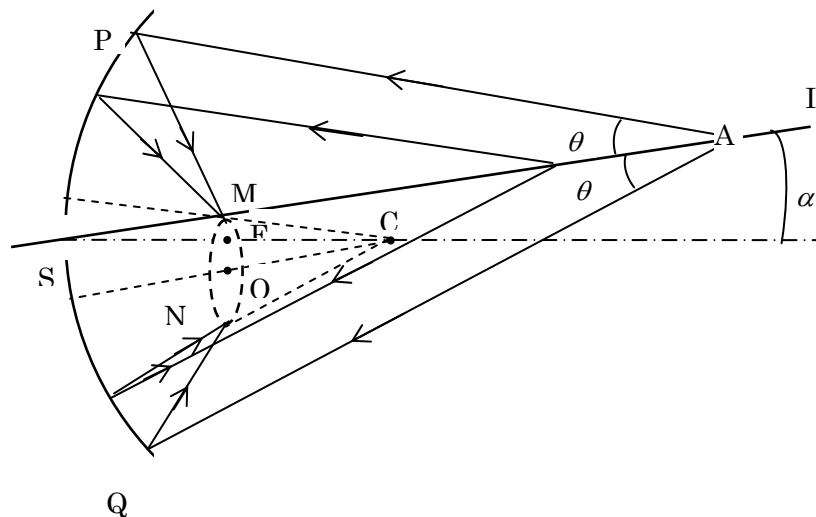

Figure 2

$$CF = FS = f$$

$$CO // IS$$

$$CM // AP$$

$$CN // AQ$$

$$\widehat{FCO} = \alpha \Rightarrow FO = f \times \alpha$$

$$\widehat{MCO} = \widehat{OCN} = \theta \Rightarrow MO = f \times \theta$$

We draw a straight line parallel to IS passing through the center C. The line intersects the focal plane at O. We have $FO \approx f \times \alpha$.

Starting from C, we draw two lines in both sides of the line CO making with it an angle θ . These two lines intersect the focal plane at M and N, respectively. All the rays of Cherenkov radiation in the plane of the sketch, striking the mirror and being reflected,

intersect at M or N.

In three-dimension case, the Cherenkov radiation gives a ring in the focal plane with the center at O ($FO \approx f \times \alpha$) and with the radius $MO \approx f \times \theta$.

In the construction, all the lines are in the plane of the sketch. Exceptionally, the ring is illustrated spatially by a dash line.

3.

3.1. For the Cherenkov effect to occur it is necessary that $n > \frac{c}{v}$, that is

$$n_{\min} = \frac{c}{v}.$$

Putting $\zeta = n - 1 = 2.7 \times 10^{-4} P$, we get

$$\zeta_{\min} = 2.7 \times 10^{-4} P_{\min} = \frac{c}{v} - 1 = \frac{1}{\beta} - 1 \quad (1)$$

Because

$$\frac{Mc^2}{pc} = \frac{Mc}{p} = \frac{Mc}{\frac{Mv}{\sqrt{1-\beta^2}}} = \frac{\sqrt{1-\beta^2}}{\beta} = K \quad (2)$$

then $K = 0.094$; 0.05 ; 0.014 for proton, kaon and pion, respectively.

From (2) we can express β through K as

$$\beta = \frac{1}{\sqrt{1+K^2}} \quad (3)$$

Since $K^2 \ll 1$ for all three kinds of particles we can neglect the terms of order higher than 2 in K . We get

$$1 - \beta = 1 - \frac{1}{\sqrt{1+K^2}} \approx \frac{1}{2} K^2 = \frac{1}{2} \left(\frac{Mc}{p} \right)^2 \quad (3a)$$

$$\frac{1}{\beta} - 1 = \sqrt{1+K^2} - 1 \approx \frac{1}{2} K^2 = \frac{1}{2} \left(\frac{Mc}{p} \right)^2 \quad (3b)$$

Putting (3b) into (1), we obtain

$$P_{\min} = \frac{1}{2.7 \times 10^{-4}} \times \frac{1}{2} K^2 \quad (4)$$

We get the following numerical values of the minimal pressure:

$$P_{\min} = 16 \text{ atm} \quad \text{for protons,}$$

$$P_{\min} = 4.6 \text{ atm} \quad \text{for kaons,}$$

$$P_{\min} = 0.36 \text{ atm} \quad \text{for pions.}$$

3.2. For $\theta_{\pi} = 2\theta_{\kappa}$ we have

$$\cos \theta_{\pi} = \cos 2\theta_{\kappa} = 2 \cos^2 \theta_{\kappa} - 1 \quad (5)$$

We denote

$$\varepsilon = 1 - \beta = 1 - \frac{1}{\sqrt{1 + K^2}} \approx \frac{1}{2} K^2 \quad (6)$$

From (5) we obtain

$$\frac{1}{\beta_{\pi} n} = \frac{2}{\beta_{\kappa}^2 n^2} - 1 \quad (7)$$

Substituting $\beta = 1 - \varepsilon$ and $n = 1 + \zeta$ into (7), we get approximately:

$$\zeta_{\frac{1}{2}} = \frac{4\varepsilon_{\kappa} - \varepsilon_{\pi}}{3} = \frac{1}{6} (4K_{\kappa}^2 - K_{\pi}^2) = \frac{1}{6} [4 \cdot (0.05)^2 - (0.014)^2],$$

$$P_{\frac{1}{2}} = \frac{1}{2.7 \times 10^{-4}} \zeta_{\frac{1}{2}} = 6 \text{ atm}.$$

The corresponding value of refraction index is $n = 1.00162$. We get:

$$\theta_{\kappa} = 1.6^{\circ}; \quad \theta_{\pi} = 2\theta_{\kappa} = 3.2^{\circ}.$$

We do not observe the ring image of protons since

$$P_{\frac{1}{2}} = 6 \text{ atm} < 16 \text{ atm} = P_{\min} \quad \text{for protons.}$$

4.

4.1. Taking logarithmic differentiation of both sides of the equation

$\cos \theta = \frac{1}{\beta n}$, we obtain

$$\frac{\sin \theta \times \Delta \theta}{\cos \theta} = \frac{\Delta \beta}{\beta} \quad (8)$$

Logarithmically differentiating equation (3a) gives

$$\frac{\Delta \beta}{1 - \beta} = 2 \frac{\Delta p}{p} \quad (9)$$

Combining (8) and (9), taking into account (3b) and putting approximately $\tan \theta = \theta$, we derive

$$\frac{\Delta \theta}{\Delta p} = \frac{2}{\theta} \times \frac{1 - \beta}{p \beta} = \frac{K^2}{\theta p} \quad (10)$$

We obtain

-for kaons $K_{\kappa} = 0.05$, $\theta_{\kappa} = 1.6^{\circ} = 1.6 \frac{\pi}{180} \text{ rad}$, and so, $\frac{\Delta \theta_{\kappa}}{\Delta p} = 0.51 \frac{1^{\circ}}{\text{GeV}/c}$,

-for pions $K_{\pi} = 0.014$, $\theta_{\pi} = 3.2^{\circ}$, and

$$\frac{\Delta \theta_{\pi}}{\Delta p} = 0.02 \frac{1^{\circ}}{\text{GeV}/c}.$$

$$4.2. \quad \frac{\Delta \theta_{\kappa} + \Delta \theta_{\pi}}{\Delta p} \equiv \frac{\Delta \theta}{\Delta p} = (0.51 + 0.02) \frac{1^{\circ}}{\text{GeV}/c} = 0.53 \frac{1^{\circ}}{\text{GeV}/c}.$$

The condition for two ring images to be distinguishable is

$$\Delta \theta < 0.1(\theta_{\pi} - \theta_{\kappa}) = 0.16^{\circ}.$$

It follows $\Delta p < \frac{1}{10} \times \frac{1.6}{0.53} = 0.3 \text{ GeV}/c$.

5.

5.1. The lower limit of β giving rise to Cherenkov effect is

$$\beta = \frac{1}{n} = \frac{1}{1.33}. \quad (11)$$

The kinetic energy of a particle having rest mass M and energy E is given by the expression

$$T = E - Mc^2 = \frac{Mc^2}{\sqrt{1-\beta^2}} - Mc^2 = Mc^2 \left[\frac{1}{\sqrt{1-\beta^2}} - 1 \right]. \quad (12)$$

Substituting the limiting value (11) of β into (12), we get the minimal kinetic energy of the particle for Cherenkov effect to occur:

$$T_{\min} = Mc^2 \left[\frac{1}{\sqrt{1-\left(\frac{1}{1.33}\right)^2}} - 1 \right] = 0.517 Mc^2 \quad (13)$$

5.2.

For α particles, $T_{\min} = 0.517 \times 3.8 \text{ GeV} = 1.96 \text{ GeV}$.

For electrons, $T_{\min} = 0.517 \times 0.51 \text{ MeV} = 0.264 \text{ MeV}$.

Since the kinetic energy of the particles emitted by radioactive source does not exceed a few MeV, these are electrons which give rise to Cherenkov radiation in the considered experiment.

6. For a beam of particles having a definite momentum the dependence of the angle θ on the refraction index n of the medium is given by the expression

$$\cos \theta = \frac{1}{n\beta} \quad (14)$$

6.1. Let $\delta\theta$ be the difference of θ between two rings corresponding to two wavelengths limiting the visible range, i.e. to wavelengths of $0.4 \mu\text{m}$ (violet) and $0.8 \mu\text{m}$ (red), respectively. The difference in the refraction indexes at these wavelengths is $n_v - n_r = \delta n = 0.02(n-1)$.

Logarithmically differentiating both sides of equation (14) gives

$$\frac{\sin \theta \times \delta \theta}{\cos \theta} = \frac{\delta n}{n} \quad (15)$$

Corresponding to the pressure of the radiator $P = 6$ atm we have from 4.2. the values $\theta_{\pi} = 3.2^{\circ}$, $n = 1.00162$.

Putting approximately $\tan \theta = \theta$ and $n = 1$, we get $\delta \theta = \frac{\delta n}{\theta} = 0.033^{\circ}$.

6.2.

6.2.1. The broadening due to dispersion in terms of half width at half height is, according to (6.1), $\frac{1}{2} \delta \theta = 0.017^{\circ}$.

6.2.2. The broadening due to achromaticity is, from 4.1., $0.02 \frac{1^{\circ}}{\text{GeV}/c} \times 0.3 \text{ GeV}/c = 0.006^{\circ}$, that is three times smaller than above.

6.2.3. The color of the ring changes from red to white then blue from the inner edge to the outer one.

Solution

1. For an altitude change dz , the atmospheric pressure change is :

$$dp = -\rho g dz \quad (1)$$

where g is the acceleration of gravity, considered constant, ρ is the specific mass of air, which is considered as an ideal gas:

$$\rho = \frac{m}{V} = \frac{p\mu}{RT}$$

Put this expression in (1) :

$$\frac{dp}{p} = -\frac{\mu g}{RT} dz$$

1.1. If the air temperature is uniform and equals T_0 , then

$$\frac{dp}{p} = -\frac{\mu g}{RT_0} dz$$

After integration, we have :

$$p(z) = p(0) e^{-\frac{\mu g}{RT_0} z} \quad (2)$$

1.2. If

$$T(z) = T(0) - \Lambda z \quad (3)$$

then

$$\frac{dp}{p} = -\frac{\mu g}{R[T(0) - \Lambda z]} dz \quad (4)$$

1.2.1. Knowing that :

$$\int \frac{dz}{T(0) - \Lambda z} = -\frac{1}{\Lambda} \int \frac{d[T(0) - \Lambda z]}{T(0) - \Lambda z} = -\frac{1}{\Lambda} \ln(T(0) - \Lambda z)$$

by integrating both members of (4), we obtain :

$$\begin{aligned} \ln \frac{p(z)}{p(0)} &= \frac{\mu g}{R\Lambda} \ln \frac{T(0) - \Lambda z}{T(0)} = \frac{\mu g}{R\Lambda} \ln \left(1 - \frac{\Lambda z}{T(0)} \right) \\ p(z) &= p(0) \left(1 - \frac{\Lambda z}{T(0)} \right)^{\frac{\mu g}{R\Lambda}} \end{aligned} \quad (5)$$

1.2.2. The free convection occurs if:

$$\frac{\rho(z)}{\rho(0)} > 1$$

The ratio of specific masses can be expressed as follows:

$$\frac{\rho(z)}{\rho(0)} = \frac{p(z)T(0)}{p(0)T(z)} = \left(1 - \frac{\Lambda z}{T(0)}\right)^{\frac{\mu g}{R\Lambda} - 1}$$

The last term is larger than unity if its exponent is negative:

$$\frac{\mu g}{R\Lambda} - 1 < 0$$

Then :

$$\Lambda > \frac{\mu g}{R} = \frac{0.029 \times 9.81}{8.31} = 0.034 \frac{\text{K}}{\text{m}}$$

2. In vertical motion, the pressure of the parcel always equals that of the surrounding air, the latter depends on the altitude. The parcel temperature T_{parcel} depends on the pressure.

2.1. We can write:

$$\frac{dT_{\text{parcel}}}{dz} = \frac{dT_{\text{parcel}}}{dp} \frac{dp}{dz}$$

p is simultaneously the pressure of air in the parcel and that of the surrounding air.

Expression for $\frac{dT_{\text{parcel}}}{dp}$

By using the equation for adiabatic processes $pV^\gamma = \text{const}$ and equation of state, we can deduce the equation giving the change of pressure and temperature in a quasi-equilibrium adiabatic process of an air parcel:

$$T_{\text{parcel}} p^{\frac{1-\gamma}{\gamma}} = \text{const} \quad (6)$$

where $\gamma = \frac{c_p}{c_v}$ is the ratio of isobaric and isochoric thermal capacities of air. By

logarithmic differentiation of the two members of (6), we have:

$$\frac{dT_{\text{parcel}}}{T_{\text{parcel}}} + \frac{1-\gamma}{\gamma} \frac{dp}{p} = 0$$

Or

$$\frac{dT_{\text{parcel}}}{dp} = \frac{T_{\text{parcel}}}{p} \frac{\gamma-1}{\gamma} \quad (7)$$

Note: we can use the first law of thermodynamic to calculate the heat received by the parcel in an elementary process: $dQ = \frac{m}{\mu} c_v dT_{\text{parcel}} + pdV$, this heat equals zero in an adiabatic process. Furthermore, using the equation of state for air in the parcel $pV = \frac{m}{\mu} RT_{\text{parcel}}$ we can derive (6)

Expression for $\frac{dp}{dz}$

From (1) we can deduce:

$$\frac{dp}{dz} = -\rho g = -\frac{pg\mu}{RT}$$

where T is the temperature of the surrounding air.

On the basis of these two expressions, we derive the expression for dT_{parcel}/dz :

$$\frac{dT_{\text{parcel}}}{dz} = -\frac{\gamma-1}{\gamma} \frac{\mu g}{R} \frac{T_{\text{parcel}}}{T} = -G \quad (8)$$

In general, G is not a constant.

2.2.

2.2.1. If at any altitude, $T = T_{\text{parcel}}$, then instead of G in (8), we have :

$$\Gamma = \frac{\gamma-1}{\gamma} \frac{\mu g}{R} = \text{const} \quad (9)$$

or

$$\Gamma = \frac{\mu g}{c_p} \quad (9')$$

2.2.2. Numerical value:

$$\Gamma = \frac{1.4 - 1}{1.4} \frac{0.029 \times 9.81}{8.31} = 0.00978 \frac{\text{K}}{\text{m}} \approx 10^{-2} \frac{\text{K}}{\text{m}}$$

2.2.3. Thus, the expression for the temperature at the altitude z in this special atmosphere (called adiabatic atmosphere) is :

$$T(z) = T(0) - \Gamma z \quad (10)$$

2.3. Search for the expression of $T_{\text{parcel}}(z)$

Substitute T in (7) by its expression given in (3), we have:

$$\frac{dT_{\text{parcel}}}{T_{\text{parcel}}} = -\frac{\gamma - 1}{\gamma} \frac{\mu g}{R} \frac{dz}{T(0) - \Lambda z}$$

Integration gives:

$$\ln \frac{T_{\text{parcel}}(z)}{T_{\text{parcel}}(0)} = -\frac{\gamma - 1}{\gamma} \frac{\mu g}{R} \left(-\frac{1}{\Lambda} \right) \ln \frac{T(0) - \Lambda z}{T(0)}$$

Finally, we obtain:

$$T_{\text{parcel}}(z) = T_{\text{parcel}}(0) \left(\frac{T(0) - \Lambda z}{T(0)} \right)^{\frac{\Gamma}{\Lambda}} \quad (11)$$

2.4.

From (11) we obtain

$$T_{\text{parcel}}(z) = T_{\text{parcel}}(0) \left(1 - \frac{\Lambda z}{T(0)} \right)^{\frac{\Gamma}{\Lambda}}$$

If $\Lambda z \ll T(0)$, then by putting $x = \frac{-T(0)}{\Lambda z}$, we obtain

$$\begin{aligned} T_{\text{parcel}}(z) &= T_{\text{parcel}}(0) \left(\left(1 + \frac{1}{x} \right)^x \right)^{\frac{\Gamma z}{T(0)}} \\ &\approx T_{\text{parcel}}(0) e^{-\frac{\Gamma z}{T(0)}} \approx T_{\text{parcel}}(0) \left(1 - \frac{\Gamma z}{T(0)} \right) \approx T_{\text{parcel}}(0) - \Gamma z \end{aligned}$$

hence,

$$T_{\text{parcel}}(z) \approx T_{\text{parcel}}(0) - \Gamma z \quad (12)$$

3. Atmospheric stability

In order to know the stability of atmosphere, we can study the stability of the equilibrium of an air parcel in this atmosphere.

At the altitude z_0 , where $T_{\text{parcel}}(z_0) = T(z_0)$, the air parcel is in equilibrium.

Indeed, in this case the specific mass ρ of air in the parcel equals ρ' - that of the surrounding air in the atmosphere. Therefore, the buoyant force of the surrounding air on the parcel equals the weight of the parcel. The resultant of these two forces is zero.

Remember that the temperature of the air parcel $T_{\text{parcel}}(z)$ is given by (7), in which we can assume approximately $G = \Gamma$ at any altitude z near $z = z_0$.

Now, consider the stability of the air parcel equilibrium:

Suppose that the air parcel is lifted into a higher position, at the altitude $z_0 + d$

(with $d > 0$), $T_{\text{parcel}}(z_0 + d) = T_{\text{parcel}}(z_0) - \Gamma d$ and $T(z_0 + d) = T(z_0) - \Lambda d$.

- In the case the atmosphere has temperature lapse rate $\Lambda > \Gamma$, we have $T_{\text{parcel}}(z_0 + d) > T(z_0 + d)$, then $\rho < \rho'$. The buoyant force is then larger than the air parcel weight, their resultant is oriented upward and tends to push the parcel away from the equilibrium position.

Conversely, if the air parcel is lowered to the altitude $z_0 - d$ ($d > 0$),

$T_{\text{parcel}}(z_0 - d) < T(z_0 - d)$ and then $\rho > \rho'$.

The buoyant force is then smaller than the air parcel weight; their resultant is oriented downward and tends to push the parcel away from the equilibrium position (see Figure 1)

So the equilibrium of the parcel is unstable, and we found that: *An atmosphere with a temperature lapse rate $\Lambda > \Gamma$ is unstable.*

- In an atmosphere with temperature lapse rate $\Lambda < \Gamma$, if the air parcel is lifted to a higher position, at altitude $z_0 + d$ (with $d > 0$), $T_{\text{parcel}}(z_0 + d) < T(z_0 + d)$, then

$\rho > \rho'$. The buoyant force is then smaller than the air parcel weight, their resultant is oriented downward and tends to push the parcel back to the equilibrium position.

Conversely, if the air parcel is lowered to altitude $z_0 - d$ ($d > 0$), $T_{\text{parcel}}(z_0 - d) > T(z_0 - d)$ and then $\rho < \rho'$. The buoyant force is then larger than the air parcel weight, their resultant is oriented upward and tends to push the parcel also back to the equilibrium position (see Figure 2).

So the equilibrium of the parcel is stable, and we found that: *An atmosphere with a temperature lapse rate $\Lambda < \Gamma$ is stable.*

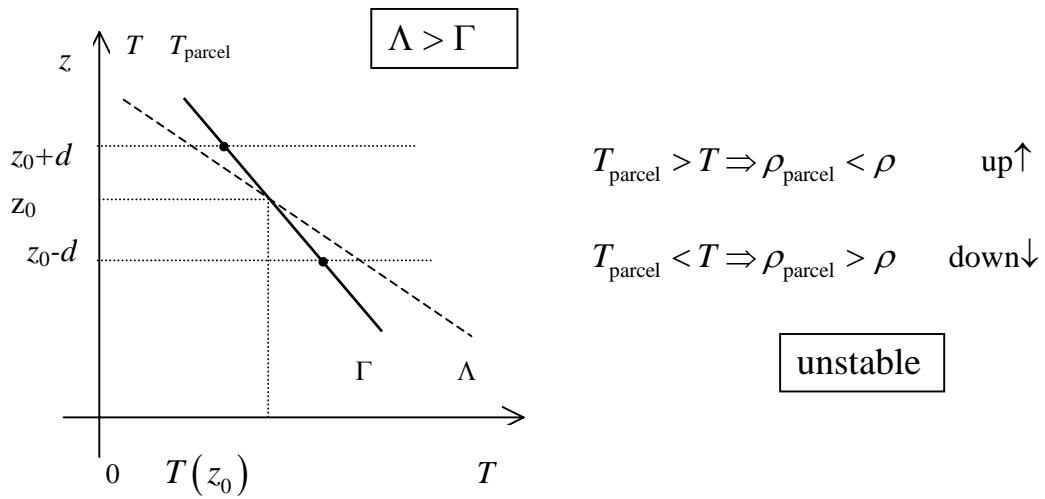

Figure 1

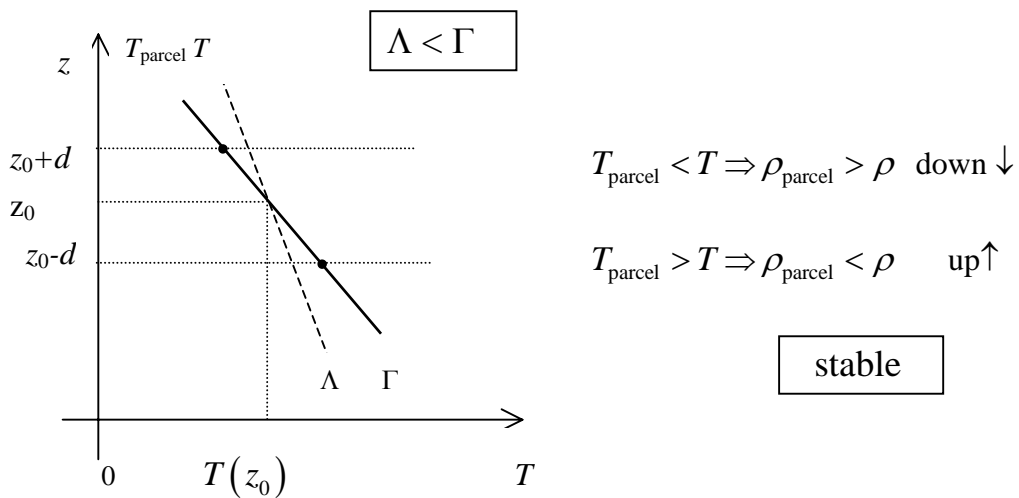

Figure 2

• In an atmosphere with lapse rate $\Lambda = \Gamma$, if the parcel is brought from equilibrium position and put in any other position, it will stay there, the equilibrium is indifferent. *An atmosphere with a temperature lapse rate $\Lambda = \Gamma$ is neutral*

3.2. In a stable atmosphere, with $\Lambda < \Gamma$, a parcel, which on ground has temperature $T_{\text{parcel}}(0) > T(0)$ and pressure $p(0)$ equal to that of the atmosphere, can rise and reach a maximal altitude h , where $T_{\text{parcel}}(h) = T(h)$.

In vertical motion from the ground to the altitude h , the air parcel realizes an adiabatic quasi-static process, in which its temperature changes from $T_{\text{parcel}}(0)$ to

$T_{\text{parcel}}(h) = T(h)$. Using (11), we can write:

$$\left(1 - \frac{\Lambda h}{T(0)}\right)^{-\frac{\Gamma}{\Lambda}} = \frac{T_{\text{parcel}}(0)}{T(h)} = \frac{T_{\text{parcel}}(0)}{T(0) \left(1 - \frac{\Lambda h}{T(0)}\right)}$$

$$\left(1 - \frac{\Lambda h}{T(0)}\right)^{1 - \frac{\Gamma}{\Lambda}} = T_{\text{parcel}}(0) \times T^{-1}(0)$$

$$1 - \frac{\Lambda h}{T(0)} = T_{\text{parcel}}^{\frac{\Lambda}{\Lambda - \Gamma}}(0) \times T^{-\frac{\Lambda}{\Lambda - \Gamma}}(0)$$

$$h = \frac{1}{\Lambda} T(0) \left[1 - T_{\text{parcel}}^{\frac{\Lambda}{\Lambda - \Gamma}}(0) \times T^{-\frac{\Lambda}{\Lambda - \Gamma}}(0) \right]$$

$$= \frac{1}{\Lambda} \left[T(0) - T_{\text{parcel}}^{\frac{\Lambda}{\Lambda - \Gamma}}(0) T^{\frac{\Gamma}{\Gamma - \Lambda}}(0) \right]$$

So that the maximal altitude h has the following expression:

$$h = \frac{1}{\Lambda} \left[T(0) - \left(\frac{(T(0))^\Gamma}{(T_{\text{parcel}}(0))^\Lambda} \right)^{\frac{1}{\Gamma - \Lambda}} \right] \quad (13)$$

4.

 Using data from the Table, we obtain the plot of z versus T shown in Figure 3.

Figure 3

4.1. We can divide the atmosphere under 200m into three layers, corresponding to the following altitudes:

$$1) \quad 0 < z < 96 \text{ m}, \quad \Lambda_1 = \frac{21.5 - 20.1}{91} = 15.4 \times 10^{-3} \frac{\text{K}}{\text{m}}.$$

$$2) \quad 96 \text{ m} < z < 119 \text{ m}, \quad \Lambda_2 = 0, \text{ isothermal layer.}$$

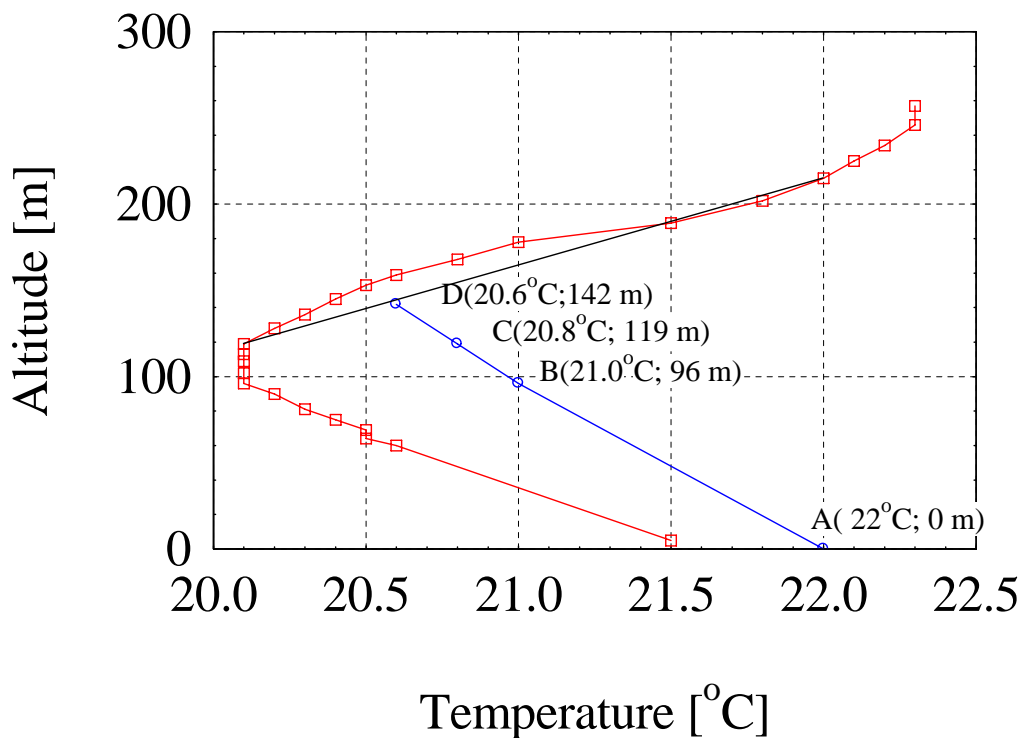
$$3) \quad 119 \text{ m} < z < 215 \text{ m}, \quad \Lambda_3 = -\frac{22 - 20.1}{215 - 119} = -0.02 \frac{\text{K}}{\text{m}}.$$

In the layer 1), the parcel temperature can be calculated by using (11)

$$T_{\text{parcel}}(96 \text{ m}) = 294.04 \text{ K} \approx 294.0 \text{ K} \quad \text{that is } 21.0^\circ\text{C}$$

In the layer 2), the parcel temperature can be calculated by using its expression in

isothermal atmosphere $T_{\text{parcel}}(z) = T_{\text{parcel}}(0) \exp\left[-\frac{\Gamma z}{T(0)}\right].$

The altitude 96 m is used as origin, corresponding to 0 m. The altitude 119 m corresponds to 23 m. We obtain the following value for parcel temperature:

$$T_{\text{parcel}}(119 \text{ m}) = 293.81 \text{ K} \quad \text{that is } 20.8^\circ\text{C}$$

4.2. In the layer 3), starting from 119 m, by using (13) we find the maximal elevation $h = 23 \text{ m}$, and the corresponding temperature 293.6 K (or 20.6°C).

Finally, the mixing height is

$$H = 119 + 23 = 142 \text{ m}.$$

And

$$T_{\text{parcel}}(142 \text{ m}) = 293.6 \text{ K} \quad \text{that is } 20.6^\circ\text{C}$$

From this relation, we can find $T_{\text{parcel}}(119 \text{ m}) \approx 293.82 \text{ K}$ and $h = 23 \text{ m}$.

Note: By using approximate expression (12) we can easily find $T_{\text{parcel}}(z) = 294 \text{ K}$ and 293.8 K at elevations 96 m and 119 m, respectively. At 119 m elevation, the difference between parcel and surrounding air temperatures is 0.7 K ($= 293.8 - 293.1$), so that the maximal distance the parcel will travel in the third layer is $0.7/(\Gamma - \Lambda_3) = 0.7/0.03 = 23 \text{ m}$.

5.

Consider a volume of atmosphere of Hanoi metropolitan area being a parallelepiped with height H , base sides L and W . The emission rate of CO gas by motorbikes from 7:00 am to 8:00 am

$$M = 800\,000 \times 5 \times 12 / 3600 = 13\,300 \text{ g/s}$$

The CO concentration in air is uniform at all points in the parallelepiped and denoted by $C(t)$.

5.1. After an elementary interval of time dt , due to the emission of the motorbikes, the mass of CO gas in the box increases by Mdt . The wind blows parallel to the short sides W , bringing away an amount of CO gas with mass $LHC(t)udt$. The remaining part raises the CO concentration by a quantity dC in all over the box. Therefore:

$$Mdt - LHC(t)udt = LWHdC$$

or

$$\frac{dC}{dt} + \frac{u}{W} C(t) = \frac{M}{LWH} \quad (14)$$

5.2. The general solution of (14) is :

$$C(t) = K \exp\left(-\frac{ut}{W}\right) + \frac{M}{LHu} \quad (15)$$

From the initial condition $C(0) = 0$, we can deduce :

$$C(t) = \frac{M}{LHu} \left[1 - \exp\left(-\frac{ut}{W}\right) \right] \quad (16)$$

5.3. Taking as origin of time the moment 7:00 am, then 8:00 am corresponds to $t = 3600$ s. Putting the given data in (15), we obtain :

$$C(3600 \text{ s}) = 6.35 \times (1 - 0.64) = 2.3 \text{ mg/m}^3$$

Solution

Task 1

1.

1.1. $T_0 = 25 \pm 1 \text{ }^\circ\text{C}$

$$V_{\text{samp}}(T_0) = 573.9 \text{ mV}$$

With different experiment sets, V_{samp} may differ from the above value within $\pm 40 \text{ mV}$.

Note for error estimation:

δV and δV are calculated using the specs of the multimeter: $\pm 0.5\%$ reading digit +2 on the last digit. Example: if $V = 500 \text{ mV}$, the error $\delta V = 500 \times 0.5\% + 0.2 = 2.7 \text{ mV} \approx 3 \text{ mV}$.

Thus, $V_{\text{samp}}(T_0) = 574 \pm 3 \text{ mV}$.

All values of $V_{\text{samp}}(T_0)$ within $505 \div 585 \text{ mV}$ are acceptable.

1.2. Formula for temperature calculation:

From Eq (1): $V_{\text{samp}} = V_{\text{samp}}(T_0) - \alpha(T - T_0)$

$$V_{\text{samp}}(50^\circ\text{C}) = 523.9 \text{ mV}$$

$$V_{\text{samp}}(70^\circ\text{C}) = 483.9 \text{ mV}$$

$$V_{\text{samp}}(80^\circ\text{C}) = 463.9 \text{ mV}$$

Error calculation: $\delta V_{\text{samp}} = \delta V_{\text{samp}}(T_0) + (T - T_0)\delta\alpha$

Example: $V_{\text{samp}} = 495.2 \text{ mV}$, then $\delta V_{\text{samp}} = 2.7 + 0.03 \times (50 - 25) = 3.45 \text{ mV} \approx 3.5 \text{ mV}$

Thus:

$$V_{\text{samp}}(50^\circ\text{C}) = 524 \pm 4 \text{ mV}$$

$$V_{\text{samp}}(70^\circ\text{C}) = 484 \pm 4 \text{ mV}$$

$$V_{\text{samp}}(80^\circ\text{C}) = 464 \pm 5 \text{ mV}$$

The same rule for acceptable range of V_{samp} as in 1.1 is applied.

2.

2.1. Data of cooling-down process without sample:

t (s)	V_{samp} (mV) ($\pm 3\text{mV}$)	ΔV (mV) ($\pm 0.2\text{mV}$)
0	492	-0.4
10	493	-0.5
20	493	-0.5
30	494	-0.6
40	495	-0.7
50	496	-0.7
60	497	-0.8
70	497	-0.8
80	498	-0.9
90	499	-1.0
100	500	-1.0
110	500	-1.1
120	501	-1.1
130	502	-1.2
140	503	-1.2
150	503	-1.3
160	504	-1.3
170	504	-1.4
180	505	-1.5
190	506	-1.6
200	507	-1.6
210	507	-1.7
220	508	-1.7
230	508	-1.8
240	509	-1.8
250	509	-1.8
260	510	-1.9
270	511	-1.9

280	512	-1.9
290	512	-2.0
300	513	-2.0
310	514	-2.1
320	515	-2.1
330	515	-2.1
340	516	-2.1
350	516	-2.2
360	517	-2.2
370	518	-2.3
380	518	-2.3
390	519	-2.3
400	520	-2.4
410	520	-2.4
420	521	-2.5
430	521	-2.5
440	522	-2.5
450	523	-2.6
460	523	-2.6

The acceptable range of ΔV is ± 40 mV. There is no fixed rule for the change in ΔV with T (this depends on the positions of the dishes on the plate, etc.)

2.2.

Graph 1

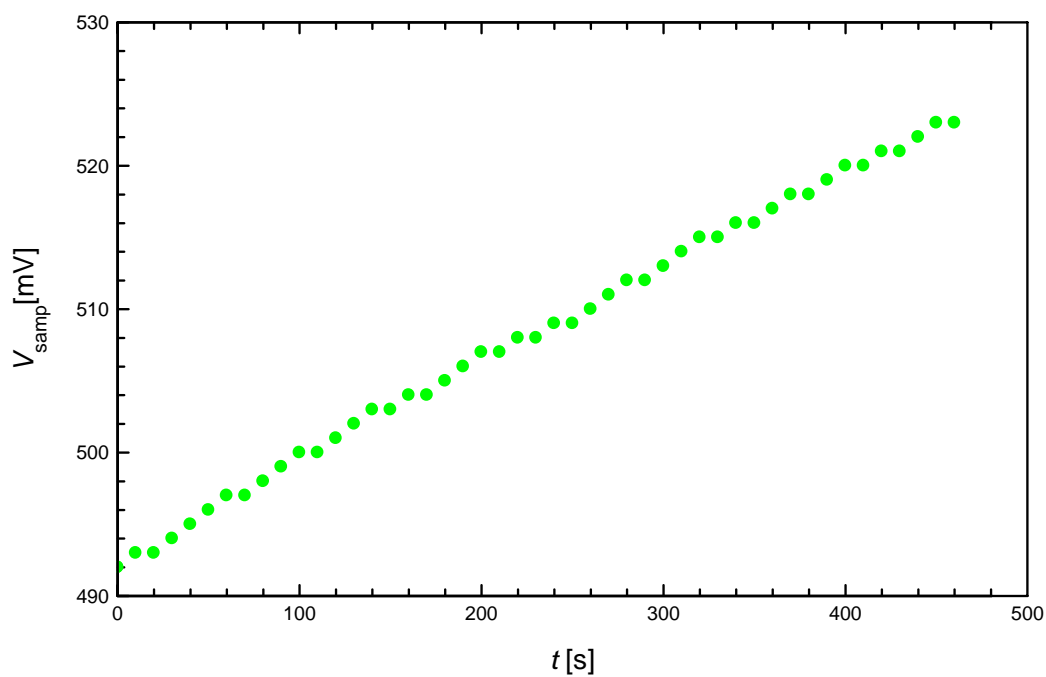

The correct graph should not have any abrupt changes of the slope.

2.3.

Graph 2

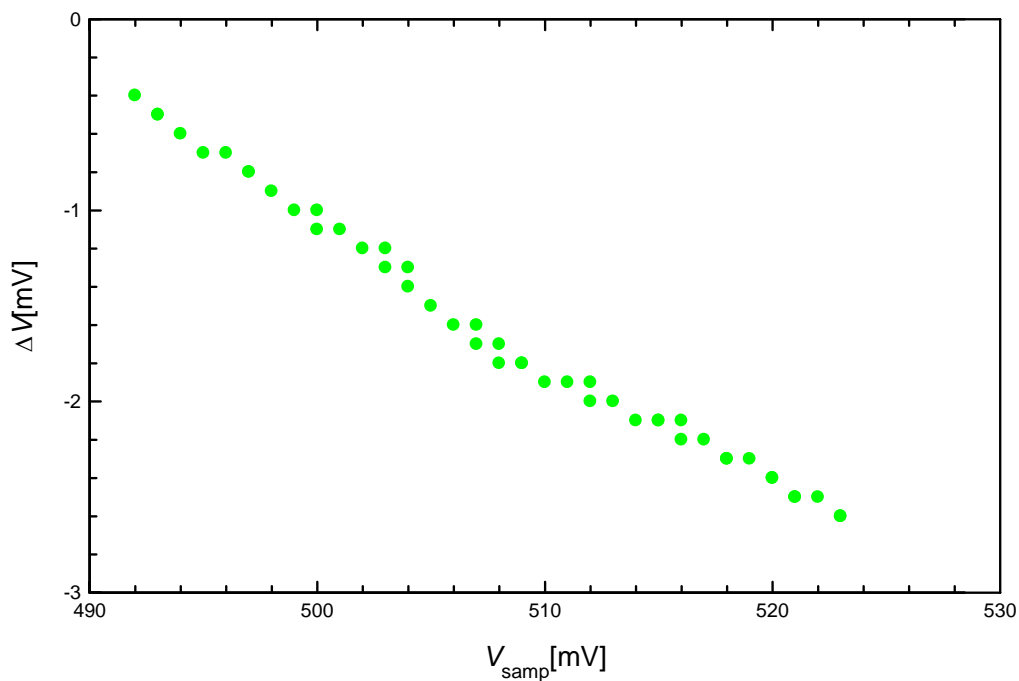

The correct graph should not have any abrupt changes of the slope.

3.

3.1. Dish with substance

t (s)	V_{samp} (mV) ($\pm 3\text{mV}$)	ΔV (mV) ($\pm 0.2\text{mV}$)
0	492	-4.6
10	493	-4.6
20	493	-4.6
30	494	-4.6
40	495	-4.6
50	496	-4.6
60	497	-4.6
70	497	-4.5
80	498	-4.5
90	499	-4.5
100	500	-4.5
110	500	-4.5
120	501	-4.5

130	502	-4.6
140	503	-4.6
150	503	-5.1
160	503	-5.6
170	503	-6.2
180	503	-6.5
190	504	-6.6
200	505	-6.5
210	506	-6.4
220	507	-6.3
230	507	-6.1
240	508	-5.9
250	509	-5.7
260	510	-5.5
270	511	-5.3
280	512	-5.1
290	512	-5.0
300	513	-4.9
310	514	-4.8
320	515	-4.7
330	515	-4.7
340	516	-4.6
350	516	-4.6
360	517	-4.5
370	518	-4.5
380	518	-4.4
390	519	-4.4
400	520	-4.4
410	520	-4.4
420	521	-4.4
430	521	-4.3
440	522	-4.3
450	523	-4.3
460	523	-4.3

3.2.

Graph 3

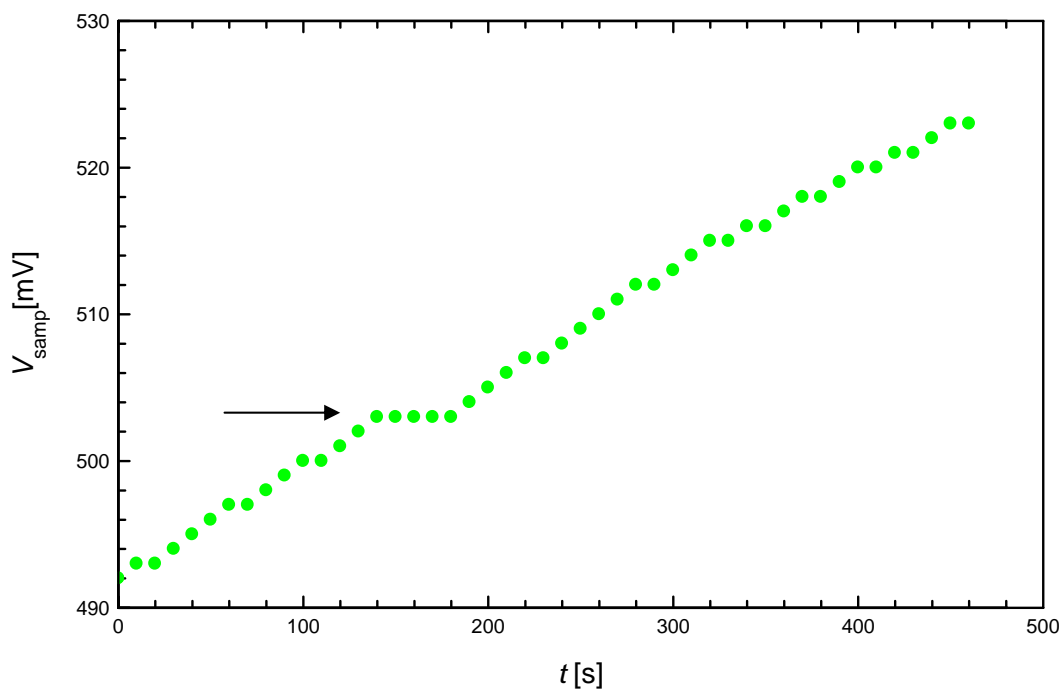

The correct Graph 3 should contain a short plateau as marked by the arrow in the above figure.

3.3.

Graph 4

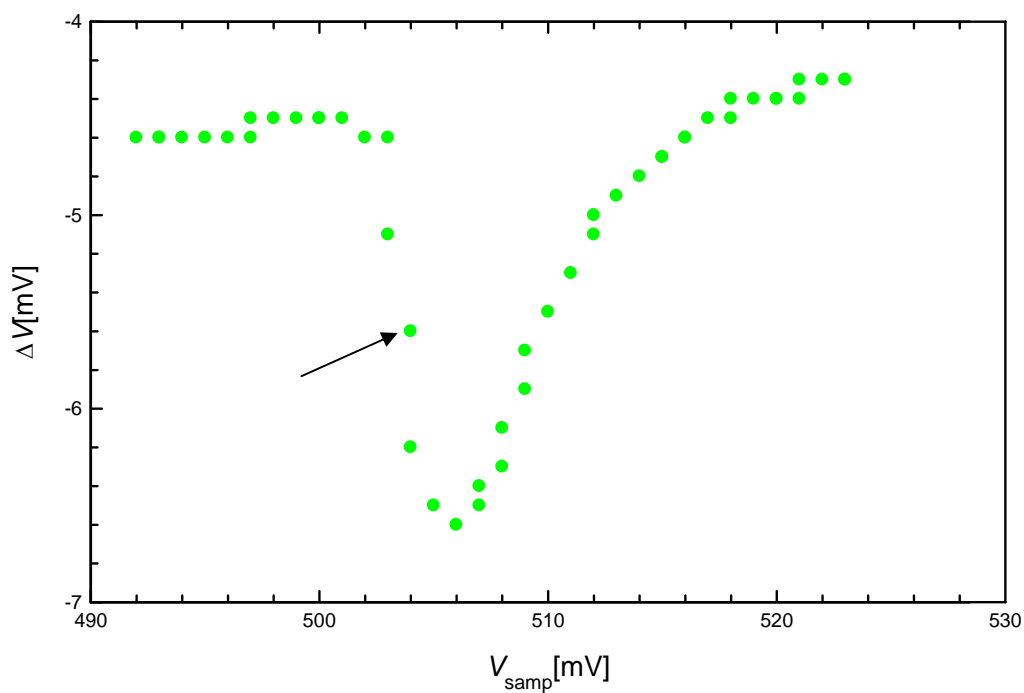

The correct Graph 4 should have an abrupt change in ΔV , as shown by the arrow in the above figure.

Note: when the dish contains the substance, values of ΔV may change compared to those without the substance.

4.

4.1. V_s is shown in Graph 3. Value $V_s = (503 \pm 3)$ mV. From that, $T_s = 60.5$ °C can be deduced.

4.2. V_s is shown in Graph 4. Value $V_s = (503 \pm 3)$ mV. From that, $T_s = 60.5$ °C can be deduced.

4.3. Error calculations, using root mean square method:

Error of T_s : $T_s = T_0 + \frac{V(T_0) - V(T_s)}{\alpha} = T_0 + A$, in which A is an intermediate variable.

Therefore error of T_s can be written as $\delta T_s = \sqrt{(\delta T_0)^2 + (\delta A)^2}$, in which $\delta \dots$ is the error.

Error for A is calculated separately:

$$\delta A = \frac{V(T_0) - V(T_s)}{\alpha} \sqrt{\left\{ \frac{\delta[V(T_0) - V(T_s)]}{V(T_0) - V(T_s)} \right\}^2 + \left(\frac{\delta \alpha}{\alpha} \right)^2}$$

in which we have:

$$\delta[V(T_0) - V(T_s)] = \sqrt{[\delta V(T_0)]^2 + [\delta V(T_s)]^2}$$

Errors of other variables in this experiment:

$$\delta T_0 = 1^\circ\text{C}$$

$$\delta V(T_0) = 3 \text{ mV, read on the multimeter.}$$

$$\delta \alpha = 0.03 \text{ mV}/^\circ\text{C}$$

$$\delta V(T_s) \approx 3 \text{ mV}$$

From the above constituent errors we have:

$$\delta[V(T_0) - V(T_s)] \approx 4.24 \text{ mV}$$

$$\delta A \approx 2.1^\circ\text{C}$$

Finally, the error of T_s is: $\delta T_s \approx 2.5^\circ\text{C}$

Hence, the final result is: $T_s = 60 \pm 2.5^\circ\text{C}$

Note: if the student uses any other reasonable error calculation method that leads to approximately the same result, it is also accepted.

Task 2

1.

1.1. $T_0 = 26 \pm 1^\circ\text{C}$

2.

2.1. Measured data with the lamp off

t (s)	$\Delta V(T_0)$ (mV) ($\pm 0.2\text{mV}$)
0	19.0
10	19.0
20	19.0
30	19.0
40	19.0
50	18.9
60	18.9
70	18.9
80	18.9
90	18.9
100	19.0
110	19.0
120	19.0

Values of $\Delta V(T_0)$ can be different from one experiment set to another. The acceptable values lie in between $-40 \div +40$ mV.

2.2. Measured data with the lamp on

t (s)	ΔV (mV) ($\pm 0.2\text{mV}$)
0	19.5
10	21.9
20	23.8
30	25.5
40	26.9
50	28.0
60	29.0
70	29.9
80	30.7
90	31.4

100	32.0
110	32.4
120	32.9

When illuminated (by the lamp) values of ΔV may change $10 \div 20$ mV compared to the initial situation (lamp off).

2.3. Measured data after turning the lamp off

t (s)	ΔV (mV) (± 0.2 mV)
0	23.2
10	22.4
20	21.6
30	21.0
40	20.5
50	20.1
60	19.6
70	19.3
80	18.9
90	18.6
100	18.4
110	18.2
120	17.9

3. Plotting graph 5 and calculating k

$$3.1. \quad x = t; \quad y = \ln[\Delta V(T_0) - \Delta V(t)]$$

Note: other reasonable ways of writing expressions for x and y that also leads to a linear relationship using **ln** are also accepted.

3.2. Graph 5

Graph 5

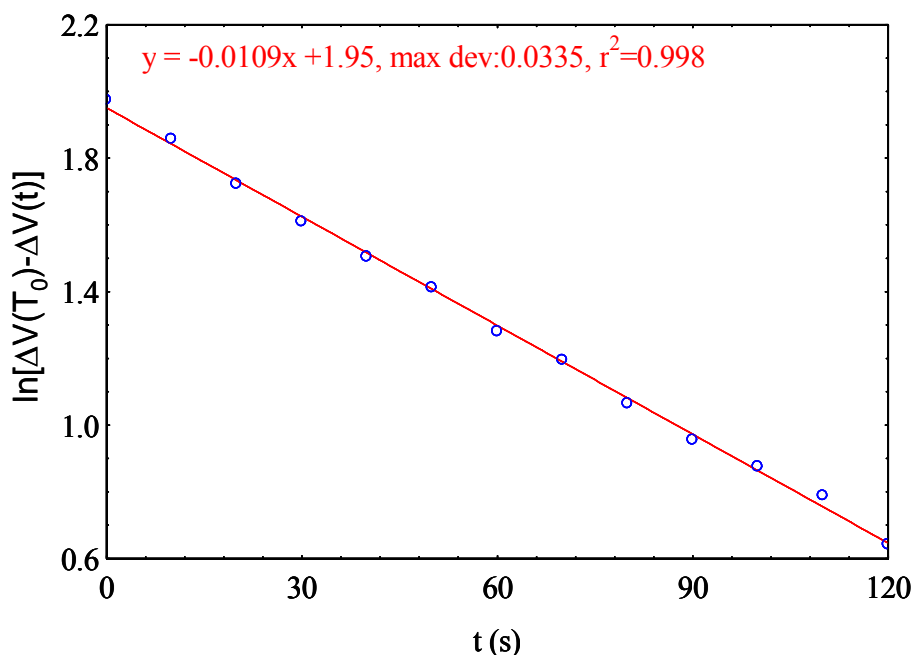

3.3. Calculating k : $\frac{k}{C} = 0.0109 \text{ s}^{-1}$ and $C = 0.69 \text{ J/K}$, thus: $k = 7.52 \times 10^{-3} \text{ W/K}$

Note: Error of k will be calculated in 5.5. Students are not asked to give error of k in this step. The acceptable value of k lies in between $6 \times 10^{-3} \div 9 \times 10^{-3} \text{ W/K}$ depending on the experiment set.

4. Plotting Graph 6 and calculating E

4.1. $x = \left[1 - \exp\left(\frac{-kt}{C}\right) \right]$; $y = |\Delta V(T_0) - \Delta V(t)|$

4.2.

Graph 6

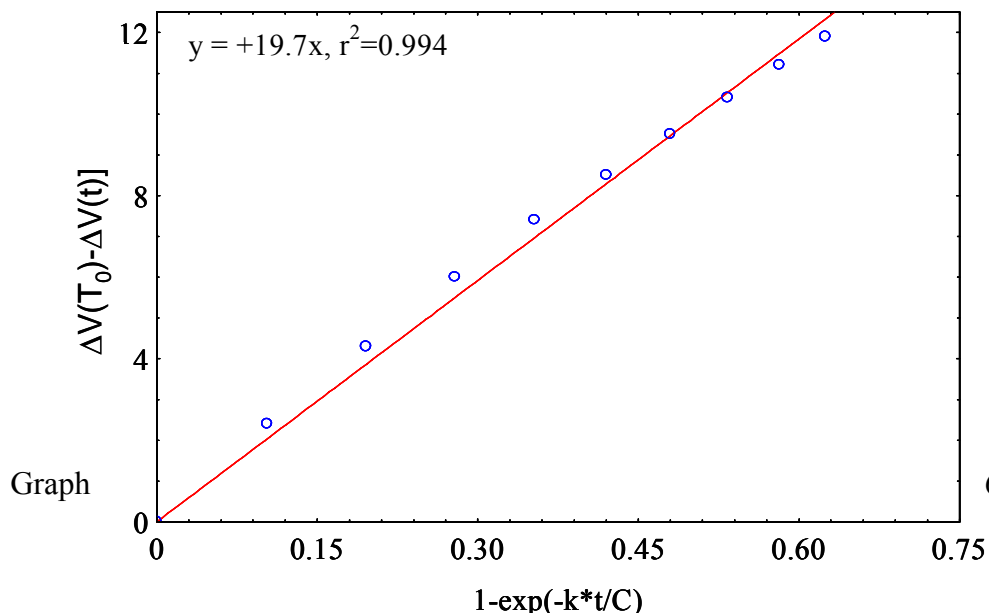

Graph

6 should

be substantially linear, with the slope in between $15 \div 25$ mV, depending on the experiment set.

4.3. From the slope of Graph 6 and the area of the detector orifice we obtain $E = 140$ W/m². The area of the detector orifice is

$$S_{\text{det}} = \pi R_{\text{det}}^2 = \pi \times (13 \times 10^{-3})^2 = 5.30 \times 10^{-4} \text{ m}^2 \text{ with error: } \frac{\delta R_{\text{det}}}{R_{\text{det}}} = 5\%$$

Error of E will be calculated in 5.5. Students are not asked to give error of E in this step. The acceptable value of E lies in between $120 \div 160$ W/m², depending on the experiment set.

5.

5.1. Circuit diagram:

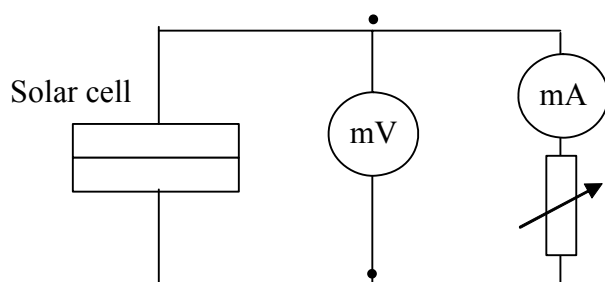

5.2. Measurements of V and I

V (mV) ($\pm 0.3 \div 3$ mV)	I (mA) ($\pm 0.05 \div 0.1$ mA)	P (mW)
18.6 ± 0.3	11.7	0.21
33.5	11.7	0.39
150	11.5	1.72
157	11.6	1.82
182 ± 1	11.4	2.08
267	11.2	3.00
402 ± 2	9.23	3.70
448	6.70	3.02
459	5.91	2.74
468	5.07	2.37
473 ± 3	4.63	2.20
480	3.81	1.86
485	3.24	1.57

487	3.12	1.54
489	3.13	1.55

5.3.

Graph 7

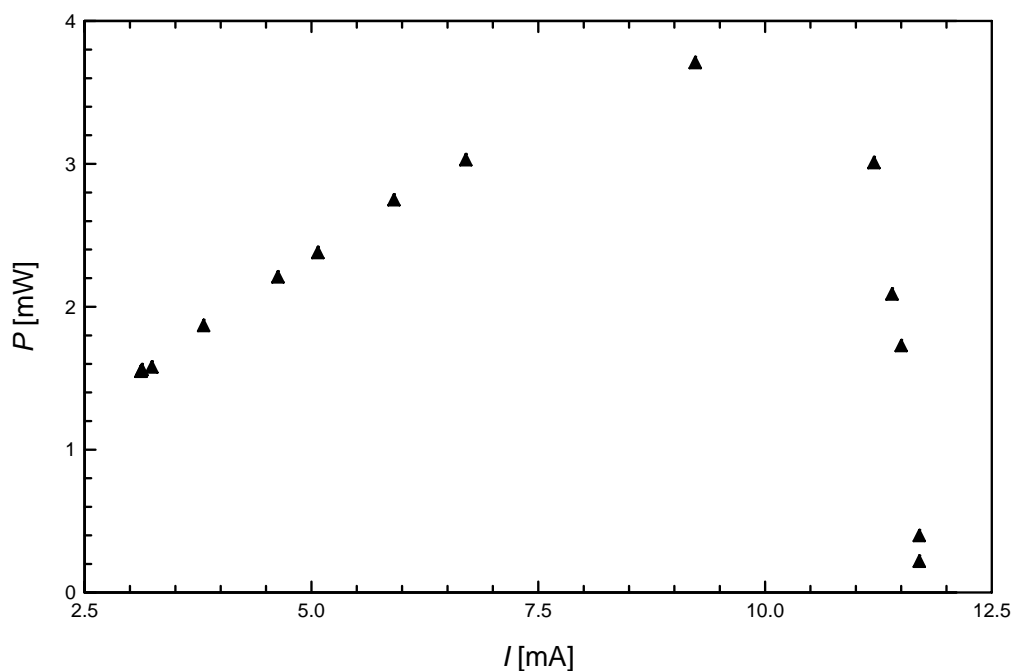
 5.4. $P_{\max} = 3.7 \pm 0.2 \text{ mW}$

The acceptable value of P_{\max} lies in between $3 \div 4.5 \text{ mW}$, depending on the experiment set.

5.5. Expression for the efficiency

$$S_{\text{cell}} = 19 \times 24 \text{ mm}^2 = 450 \times 10^{-6} \text{ m}^2$$

$$\text{Then } \eta_{\max} = \frac{P_{\max}}{E \times S_{\text{cell}}} = 0.058$$

Error calculation:

$$\delta \eta_{\max} = \eta_{\max} \sqrt{\left(\frac{\delta P_{\max}}{P_{\max}}\right)^2 + \left(\frac{\delta E}{E}\right)^2 + \left(\frac{\delta S_{\text{cell}}}{S_{\text{cell}}}\right)^2}, \text{ in which } S_{\text{cell}} \text{ is the area of the}$$

solar cell.

$$\frac{\delta P_{\max}}{P_{\max}} \text{ is estimated from Graph 7, typical value } \approx 6 \%$$

$$\frac{\delta S_{\text{cell}}}{S_{\text{cell}}} : \text{error from the millimeter measurement (with the ruler), typical value } \approx 5 \%$$

E is calculated from averaging the ratio (using Graph 6):

$$B = \frac{\Delta V(T_0) - \Delta V(t)}{1 - \exp\left(-\frac{k}{C}t\right)} = \frac{E\pi R_{\text{det}}^2 \alpha}{k}$$

in which B is an intermediate variable, R_{det} is the radius of the detector orifice.

$$E = \frac{kB}{\pi R_{\text{det}}^2 \alpha}$$

Calculation of error of E :

$$\left(\frac{\delta E}{E}\right) = \sqrt{\left(\frac{\delta k}{k}\right)^2 + \left(\frac{\delta B}{B}\right)^2 + 4\left(\frac{\delta R_{\text{det}}}{R_{\text{det}}}\right)^2 + \left(\frac{\delta \alpha}{\alpha}\right)^2}$$

k is calculated from the regression of:

$$\Delta T = \Delta T(0) \exp\left(-\frac{k}{C}t\right), \text{ hence } \ln \Delta T = \ln \Delta T(0) - \frac{k}{C}t$$

We set $k/C = m$ then $k = mC$

From the regression, we can calculate the error of m :

$$\frac{\delta m}{m} \approx 2(1-r) \approx 0.2\%$$

$$\frac{\delta k}{k} = \sqrt{\left(\frac{\delta m}{m}\right)^2 + \left(\frac{\delta C}{C}\right)^2}$$

We derive the expression for the error of η_{max} :

$$\delta \eta_{\text{max}} = \eta_{\text{max}} \sqrt{\left(\frac{\delta P_{\text{max}}}{P_{\text{max}}}\right)^2 + \left(\frac{\delta S_{\text{cell}}}{S_{\text{cell}}}\right)^2 + \left(\frac{\delta B}{B}\right)^2 + 4\left(\frac{\delta R_{\text{det}}}{R_{\text{det}}}\right)^2 + \left(\frac{\delta m}{m}\right)^2 + \left(\frac{\delta C}{C}\right)^2 + \left(\frac{\delta \alpha}{\alpha}\right)^2}$$

Typical values for η_{max} and other constituent errors:

$$\eta_{\text{max}} \approx 0.058$$

$$\frac{\delta P_{\text{max}}}{P_{\text{max}}} = 5\% ; \quad \frac{\delta B}{B} \approx 0.6\% ; \quad \frac{\delta m}{m} \approx 0.2\% ; \quad \frac{\delta S_{\text{cell}}}{S_{\text{cell}}} \approx 5\% ; \quad \frac{\delta R_{\text{det}}}{R_{\text{det}}} \approx 5\% ;$$

$$\frac{\delta C}{C} \approx 3\%; \frac{\delta k}{k} \approx 3\%; \frac{\delta E}{E} \approx 10.5\%; \frac{\delta \alpha}{\alpha} \approx 1.5\%$$

Finally:

$$\frac{\delta \eta_{\max}}{\eta_{\max}} = 12.7\%; \delta \eta_{\max} \approx 0.0074$$

and

$$\eta_{\max} = (5.8 \pm 0.8)\%$$

Note: if the student uses any other reasonable error method that leads to approximately the same result, it is also accepted.

THEORETICAL PROBLEM No. 1

EVOLUTION OF THE EARTH-MOON SYSTEM

Scientists can determine the distance Earth-Moon with great precision. They achieve this by bouncing a laser beam on special mirrors deposited on the Moon's surface by astronauts in 1969, and measuring the round travel time of the light (see Figure 1).



Figure 1. A laser beam sent from an observatory is used to measure accurately the distance between the Earth and the Moon.

With these observations, they have directly measured that the Moon is slowly receding from the Earth. That is, the Earth-Moon distance is increasing with time. This is happening because due to tidal torques the Earth is transferring angular momentum to the Moon, see Figure 2. In this problem you will derive the basic parameters of the phenomenon.

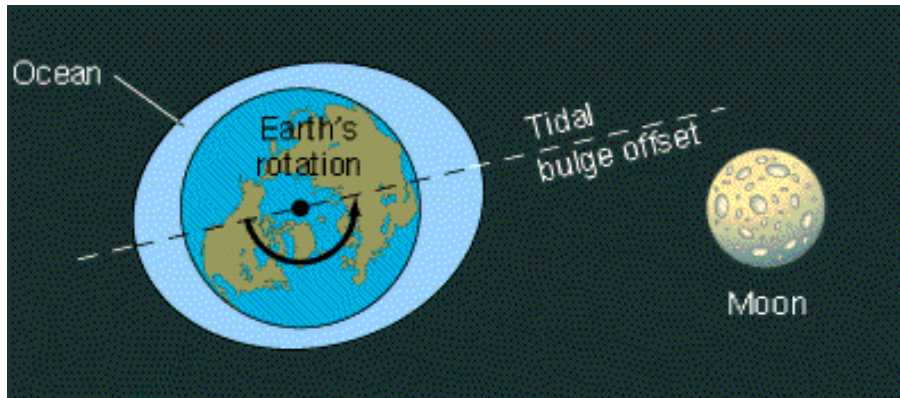

Figure 2. The Moon's gravity produces tidal deformations or "bulges" in the Earth. Because of the Earth's rotation, the line that goes through the bulges is not aligned with the line between the Earth and the Moon. This misalignment produces a torque that transfers angular momentum from the Earth's rotation to the Moon's translation. The drawing is not to scale.

1. Conservation of Angular Momentum.

Let L_1 be the present total angular momentum of the Earth-Moon system. Now, make the following assumptions: i) L_1 is the sum of the rotation of the Earth around its axis and the translation of the Moon in its orbit around the Earth only. ii) The Moon's orbit is circular and the Moon can be taken as a point. iii) The Earth's axis of rotation and the Moon's axis of revolution are parallel. iv) To simplify the calculations, we take the motion to be around the center of the Earth and not the center of mass. Throughout the problem, all moments of inertia, torques and angular momenta are defined around the axis of the Earth. v) Ignore the influence of the Sun.

1a	Write down the equation for the present total angular momentum of the Earth-Moon system. Set this equation in terms of I_E , the moment of inertia of the Earth; ω_{E1} , the present angular frequency of the Earth's rotation; I_{M1} , the present moment of inertia of the Moon with respect to the Earth's axis; and ω_{M1} , the present angular frequency of the Moon's orbit.	0.2
----	---	-----

This process of transfer of angular momentum will end when the period of rotation of the Earth and the period of revolution of the Moon around the Earth have the same duration. At this point the tidal bulges produced by the Moon on the Earth will be aligned with the line between the Moon and the Earth and the torque will disappear.

1b	Write down the equation for the final total angular momentum L_2 of the Earth-Moon system. Make the same assumptions as in Question 1a. Set this equation in terms of I_E , the moment of inertia of the Earth; ω_2 , the final angular frequency of the Earth's rotation and Moon's translation; and I_{M_2} , the final moment of inertia of the Moon.	0.2
----	---	-----

1c	Neglecting the contribution of the Earth's rotation to the final total angular momentum, write down the equation that expresses the angular momentum conservation for this problem.	0.3
----	---	-----

2. Final Separation and Final Angular Frequency of the Earth-Moon System.

Assume that the gravitational equation for a circular orbit (of the Moon around the Earth) is always valid. Neglect the contribution of the Earth's rotation to the final total angular momentum.

2a	Write down the gravitational equation for the circular orbit of the Moon around the Earth, at the final state, in terms of M_E , ω_2 , G and the final separation D_2 between the Earth and the Moon. M_E is the mass of the Earth and G is the gravitational constant.	0.2
----	--	-----

2b	Write down the equation for the final separation D_2 between the Earth and the Moon in terms of the known parameters, L_1 , the total angular momentum of the system, M_E and M_M , the masses of the Earth and Moon, respectively, and G .	0.5
----	---	-----

2c	Write down the equation for the final angular frequency ω_2 of the Earth-Moon system in terms of the known parameters L_1 , M_E , M_M and G .	0.5
----	--	-----

Below you will be asked to find the numerical values of D_2 and ω_2 . For this you need to know the moment of inertia of the Earth.

2d	Write down the equation for the moment of inertia of the Earth I_E assuming it is a sphere with inner density ρ_i from the center to a radius r_i , and with outer density ρ_o from the radius r_i to the surface at a radius r_o (see Figure 3).	0.5
----	---	-----

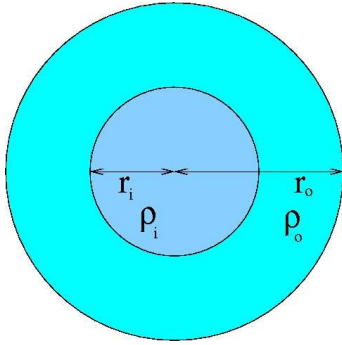

Figure 3. The Earth as a sphere with two densities, ρ_i and ρ_o .

Determine the numerical values requested in this problem always to *two significant digits*.

2e	Evaluate the moment of inertia of the Earth I_E , using $\rho_i = 1.3 \times 10^4 \text{ kg m}^{-3}$, $r_i = 3.5 \times 10^6 \text{ m}$, $\rho_o = 4.0 \times 10^3 \text{ kg m}^{-3}$, and $r_o = 6.4 \times 10^6 \text{ m}$.	0.2
----	---	-----

The masses of the Earth and Moon are $M_E = 6.0 \times 10^{24} \text{ kg}$ and $M_M = 7.3 \times 10^{22} \text{ kg}$, respectively. The present separation between the Earth and the Moon is $D_1 = 3.8 \times 10^8 \text{ m}$. The present angular frequency of the Earth's rotation is $\omega_{E1} = 7.3 \times 10^{-5} \text{ s}^{-1}$. The present angular frequency of the Moon's translation around the Earth is $\omega_{M1} = 2.7 \times 10^{-6} \text{ s}^{-1}$, and the gravitational constant is $G = 6.7 \times 10^{-11} \text{ m}^3 \text{ kg}^{-1} \text{ s}^{-2}$.

2f	Evaluate the numerical value of the total angular momentum of the system, L_1 .	0.2
----	---	-----

2g	Find the final separation D_2 in meters and in units of the present separation D_1 .	0.3
----	--	-----

2h	Find the final angular frequency ω_2 in s^{-1} , as well as the final duration of the day in units of present days.	0.3
----	---	-----

Verify that the assumption of neglecting the contribution of the Earth's rotation to the final total angular momentum is justified by finding the ratio of the final angular momentum of the Earth to that of the Moon. This should be a small quantity.

2i	Find the ratio of the final angular momentum of the Earth to that of the Moon.	0.2
----	--	-----

3. How much is the Moon receding per year?

Now, you will find how much the Moon is receding from the Earth each year. For this, you will need to know the equation for the torque acting at present on the Moon. Assume that the tidal bulges can be approximated by two point masses, each of mass m , located on the surface of the Earth, see Fig. 4. Let θ be the angle between the line that goes through the bulges and the line that joins the centers of the Earth and the Moon.

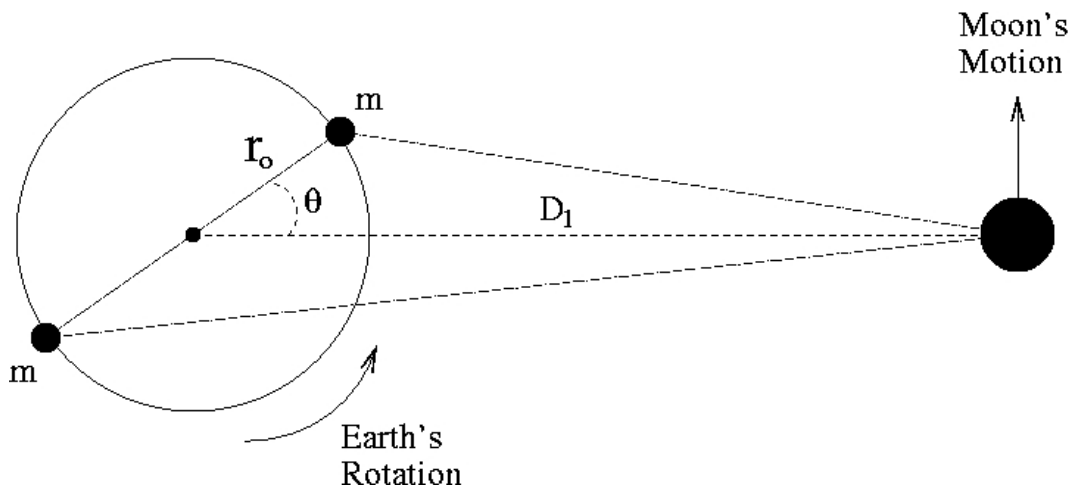

Figure 4. Schematic diagram to estimate the torque produced on the Moon by the bulges on the Earth. The drawing is not to scale.

3a	Find F_c , the magnitude of the force produced on the Moon by the closest point mass.	0.4
----	---	-----

3b	Find F_f , the magnitude of the force produced on the Moon by the farthest point mass.	0.4
----	--	-----

You may now evaluate the torques produced by the point masses.

3c	Find the magnitude of τ_c , the torque produced by the closest point mass.	0.4
----	---	-----

3d	Find the magnitude of τ_f , the torque produced by the farthest point mass.	0.4
----	--	-----

3e	Find the magnitude of the total torque τ produced by the two masses. Since $r_o \ll D_1$ you should approximate your expression to lowest significant order in r_o / D_1 . You may use that $(1+x)^a \approx 1+ax$, if $x \ll 1$.	1.0
----	--	-----

3f	Calculate the numerical value of the total torque τ , taking into account that $\theta = 3^\circ$ and that $m = 3.6 \times 10^{16}$ kg (note that this mass is of the order of 10^{-8} times the mass of the Earth).	0.5
----	---	-----

Since the torque is the rate of change of angular momentum with time, find the increase in the distance Earth-Moon at present, per year. For this step, express the angular momentum of the Moon in terms of M_M , M_E , D_1 and G only.

3g	Find the increase in the distance Earth-Moon at present, per year.	1.0
----	--	-----

Finally, estimate how much the length of the day is increasing each year.

3h	Find the decrease of ω_{E1} per year and how much is the length of the day at present increasing each year.	1.0
----	--	-----

4. Where is the energy going?

In contrast to the angular momentum, that is conserved, the total (rotational plus gravitational) energy of the system is not. We will look into this in this last section.

4a	Write down an equation for the total (rotational plus gravitational) energy of the Earth-Moon system at present, E . Put this equation in terms of I_E , ω_{E1} , M_M , M_E , D_1 and G only.	0.4
----	--	-----

4b	Write down an equation for the change in E , ΔE , as a function of the changes in D_1 and in ω_{E1} . Evaluate the numerical value of ΔE for a year, using the values of changes in D_1 and in ω_{E1} found in questions 3g and 3h.	0.4
----	---	-----

Verify that this loss of energy is consistent with an estimate for the energy dissipated as heat in the tides produced by the Moon on the Earth. Assume that the tides rise, on the average by 0.5 m, a layer of water $h = 0.5$ m deep that covers the surface of the Earth (for simplicity assume that all the surface of the Earth is covered with water). This happens twice a day. Further assume that 10% of this gravitational energy is dissipated as heat due to viscosity when the water descends. Take the density of water to be $\rho_{water} = 10^3 \text{ kg m}^{-3}$, and the gravitational acceleration on the surface of the Earth to be $g = 9.8 \text{ m s}^{-2}$.

4c	What is the mass of this surface layer of water?	0.2
4d	Calculate how much energy is dissipated in a year? How does this compare with the energy lost per year by the Earth-Moon system at present?	0.3

Answer Form
Theoretical Problem No. 1
Evolution of the Earth-Moon System

1. Conservation of Angular Momentum

1a		0.2
----	--	-----

1b		0.2
----	--	-----

1c		0.3
----	--	-----

2. Final Separation and Angular Frequency of the Earth-Moon System.

2a		0.2
----	--	-----

2b		0.5
----	--	-----

2c		0.5
----	--	-----

2d		0.5
----	--	-----

2e		0.2
----	--	-----

2f		0.2
----	--	-----

2g		0.3
----	--	-----

2h		0.3
----	--	-----

2i		0.2
----	--	-----

3. How much is the Moon receding per year?

3a		0.4
----	--	-----

3b		0.4
----	--	-----

3c		0.4
----	--	-----

3d		0.4
----	--	-----

3e		1.0
----	--	-----

3f		0.5
----	--	-----

3g		1.0
----	--	-----

3h		1.0
----	--	-----

4. Where is the energy going?

4a		0.4
----	--	-----

4b		0.4
----	--	-----

4c		0.2
----	--	-----

4d		0.3
----	--	-----

THEORETICAL PROBLEM 2

DOPPLER LASER COOLING AND OPTICAL MOLASSES

The purpose of this problem is to develop a simple theory to understand the so-called “laser cooling” and “optical molasses” phenomena. This refers to the cooling of a beam of neutral atoms, typically alkaline, by counterpropagating laser beams with the same frequency. This is part of the Physics Nobel Prize awarded to S. Chu, P. Phillips and C. Cohen-Tannoudji in 1997.



The image above shows sodium atoms (the bright spot in the center) trapped at the intersection of three orthogonal pairs of opposing laser beams. The trapping region is called “optical molasses” because the dissipative optical force resembles the viscous drag on a body moving through molasses.

In this problem you will analyze the basic phenomenon of the interaction between a photon incident on an atom and the basis of the dissipative mechanism in one dimension.

PART I: BASICS OF LASER COOLING

Consider an atom of mass m moving in the $+x$ direction with velocity v . For simplicity, we shall consider the problem to be one-dimensional, namely, we shall ignore the y and z directions (see figure 1). The atom has two internal energy levels. The energy of the lowest state is considered to be zero and the energy of the excited state to be $\hbar\omega_0$, where $\hbar = h/2\pi$. The atom is initially in the lowest state. A laser beam with frequency ω_L in the laboratory is directed in the $-x$ direction and it is incident on the atom. Quantum mechanically the laser is composed of a large number of photons, each with energy $\hbar\omega_L$ and momentum $-\hbar q$. A photon can be absorbed by the atom and later spontaneously emitted; this emission can occur with equal probabilities along the $+x$ and $-x$ directions. Since the atom moves at non-relativistic speeds, $v/c \ll 1$ (with c the speed of light) keep terms up to first order in this quantity only. Consider also $\hbar q/mv \ll 1$, namely, that the momentum of the atom is much larger than the

momentum of a single photon. In writing your answers, keep only corrections linear in either of the above quantities.

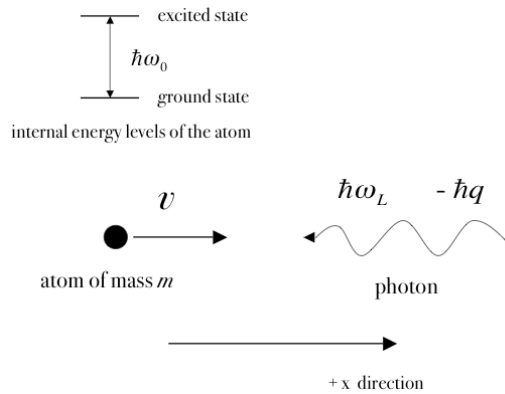

Fig.1 Sketch of an atom of mass m with velocity v in the $+x$ direction, colliding with a photon with energy $\hbar\omega_L$ and momentum $-\hbar q$. The atom has two internal states with energy difference $\hbar\omega_0$.

Assume that the laser frequency ω_L is tuned such that, as seen by the moving atom, it is in resonance with the internal transition of the atom. Answer the following questions:

1. Absorption.

1a	Write down the resonance condition for the absorption of the photon.	0.2
1b	Write down the momentum p_{at} of the atom after absorption, as seen in the laboratory.	0.2
1c	Write down the total energy \mathcal{E}_{at} of the atom after absorption, as seen in the laboratory.	0.2

2. Spontaneous emission of a photon in the $-x$ direction.

At some time after the absorption of the incident photon, the atom may emit a photon in the $-x$ direction.

2a	Write down the energy of the emitted photon, \mathcal{E}_{ph} , after the emission process in the $-x$ direction, as seen in the laboratory.	0.2
2b	Write down the momentum of the emitted photon p_{ph} , after the emission process in the $-x$ direction, as seen in the laboratory.	0.2

2c	Write down the momentum of the atom p_{at} , after the emission process in the $-x$ direction, as seen in the laboratory.	0.2
----	---	-----

2d	Write down the total energy of the atom ε_{at} , after the emission process in the $-x$ direction, as seen in the laboratory.	0.2
----	---	-----

3. Spontaneous emission of a photon in the $+x$ direction.

At some time after the absorption of the incident photon, the atom may instead emit a photon in the $+x$ direction.

3a	Write down the energy of the emitted photon, ε_{ph} , after the emission process in the $+x$ direction, as seen in the laboratory.	0.2
----	--	-----

3b	Write down the momentum of the emitted photon p_{ph} , after the emission process in the $+x$ direction, as seen in the laboratory.	0.2
----	---	-----

3c	Write down the momentum of the atom p_{at} , after the emission process in the $+x$ direction, as seen in the laboratory.	0.2
----	---	-----

3d	Write down the total energy of the atom ε_{at} , after the emission process in the $+x$ direction, as seen in the laboratory.	0.2
----	---	-----

4. Average emission after the absorption.

The spontaneous emission of a photon in the $-x$ or in the $+x$ directions occurs with the same probability. Taking this into account, answer the following questions.

4a	Write down the average energy of an emitted photon, ε_{ph} , after the emission process.	0.2
----	--	-----

4b	Write down the average momentum of an emitted photon p_{ph} , after the emission process.	0.2
----	---	-----

4c	Write down the average total energy of the atom ε_{at} , after the emission process.	0.2
----	--	-----

4d	Write down the average momentum of the atom p_{at} , after the emission process.	0.2
----	--	-----

5. Energy and momentum transfer.

Assuming a complete one-photon absorption-emission process only, as described above, there is a net average momentum and energy transfer between the laser radiation and the atom.

5a	Write down the average energy change $\Delta\epsilon$ of the atom after a complete one-photon absorption-emission process.	0.2
----	--	-----

5b	Write down the average momentum change Δp of the atom after a complete one-photon absorption-emission process.	0.2
----	--	-----

6. Energy and momentum transfer by a laser beam along the $+x$ direction.

Consider now that a laser beam of frequency ω'_L is incident on the atom along the $+x$ direction, while the atom moves also in the $+x$ direction with velocity v . Assuming a resonance condition between the internal transition of the atom and the laser beam, as seen by the atom, answer the following questions:

6a	Write down the average energy change $\Delta\epsilon$ of the atom after a complete one-photon absorption-emission process.	0.3
----	--	-----

6b	Write down the average momentum change Δp of the atom after a complete one-photon absorption-emission process.	0.3
----	--	-----

PART II: DISSIPATION AND THE FUNDAMENTALS OF OPTICAL MOLASSES

Nature, however, imposes an inherent uncertainty in quantum processes. Thus, the fact that the atom can spontaneously emit a photon in a *finite* time after absorption, gives as a result that the resonance condition does not have to be obeyed *exactly* as in the discussion above. That is, the frequency of the laser beams ω_L and ω'_L may have any value and the absorption-emission process can still occur. These will happen with different (quantum) probabilities and, as one should expect, the maximum probability is found at the exact resonance condition. On the average, the time elapsed between a single process of absorption and emission is called the lifetime of the excited energy level of the atom and it is denoted by Γ^{-1} .

Consider a collection of N atoms at *rest* in the laboratory frame of reference, and a

laser beam of frequency ω_L incident on them. The atoms absorb and emit continuously such that there is, on average, N_{exc} atoms in the excited state (and therefore, $N - N_{exc}$ atoms in the ground state). A quantum mechanical calculation yields the following result:

$$N_{exc} = N \frac{\Omega_R^2}{(\omega_0 - \omega_L)^2 + \frac{\Gamma^2}{4} + 2\Omega_R^2}$$

where ω_0 is the resonance frequency of the atomic transition and Ω_R is the so-called Rabi frequency; Ω_R^2 is proportional to the *intensity* of the laser beam. As mentioned above, you can see that this number is different from zero even if the resonance frequency ω_0 is different from the frequency of the laser beam ω_L . An alternative way of expressing the previous result is that the number of absorption-emission processes per unit of time is $N_{exc}\Gamma$.

Consider the physical situation depicted in Figure 2, in which two counter propagating laser beams with the *same* but *arbitrary* frequency ω_L are incident on a gas of N atoms that move in the $+x$ direction with velocity v .

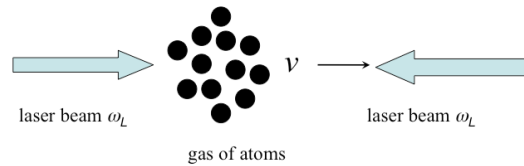

Figure 2. Two counter propagating laser beams with the *same* but *arbitrary* frequency ω_L are incident on a gas of N atoms that move in the $+x$ direction with velocity v .

7. Force on the atomic beam by the lasers.

7a	With the information found so far, find the force that the lasers exert on the atomic beam. You should assume that $mv \gg \hbar q$.	1.5
----	---	-----

8. Low velocity limit.

Assume now that the velocity of the atoms is small enough, such that you can expand the force up to first order in v .

8a	Find an expression for the force found in Question (7a), in this limit.	1.5
----	---	-----

Using this result, you can find the conditions for speeding up, slowing down, or no effect at all on the atoms by the laser radiation.

8b	Write down the condition to obtain a positive force (speeding up the atoms).	0.25
----	--	------

8c	Write down the condition to obtain a zero force.	0.25
----	--	------

8d	Write down the condition to obtain a negative force (slowing down the atoms).	0.25
----	---	------

8e	Consider now that the atoms are moving with a velocity $-v$ (in the $-x$ direction). Write down the condition to obtain a slowing down force on the atoms.	0.25
----	--	------

9. Optical molasses.

In the case of a negative force, one obtains a frictional dissipative force. Assume that initially, at $t=0$, the gas of atoms has velocity v_0 .

9a	In the limit of low velocities, find the velocity of the atoms after the laser beams have been on for a time τ .	1.5
----	---	-----

9b	Assume now that the gas of atoms is in thermal equilibrium at a temperature T_0 . Find the temperature T after the laser beams have been on for a time τ .	0.5
----	---	-----

This model does not allow you to go to arbitrarily low temperatures.

Answer Form
Theoretical problem No. 2

DOPPLER LASER COOLING AND OPTICAL MOLASSES

PART I: BASICS OF LASER COOLING

1. Absorption.

1a		0.2
----	--	-----

1b		0.2
----	--	-----

1c		0.2
----	--	-----

2. Spontaneous emission in the $-x$ direction.

2a		0.2
----	--	-----

2b		0.2
----	--	-----

2c		0.2
----	--	-----

2d		0.2
----	--	-----

3. Spontaneous emission in the $+x$ direction.

3a		0.2
----	--	-----

3b		0.2
----	--	-----

3c		0.2
----	--	-----

3d		0.2
----	--	-----

4. Average emission after absorption.

4a		0.2
----	--	-----

4b		0.2
----	--	-----

4c		0.2
----	--	-----

4d		0.2
----	--	-----

5. Energy and momentum transfer.

5a		0.2
----	--	-----

5b		0.2
----	--	-----

6. Energy and momentum transfer by a laser beam along the $+x$ direction.

6a		0.3
----	--	-----

6b		0.3
----	--	-----

PART II: DISSIPATION AND THE FUNDAMENTALS OF OPTICAL MOLASSES

7. Force on the atomic beam by the lasers.

7a		1.5
----	--	-----

8. Low velocity limit.

8a		1.5
----	--	-----

8b		0.25
----	--	------

8c		0.25
----	--	------

8d		0.25
----	--	------

8e		0.25
----	--	------

9. Optical molasses

9a		1.5
----	--	-----

9b		0.5
----	--	-----

THEORETICAL PROBLEM No. 3

WHY ARE STARS SO LARGE?

The stars are spheres of hot gas. Most of them shine because they are fusing hydrogen into helium in their central parts. In this problem we use concepts of both classical and quantum mechanics, as well as of electrostatics and thermodynamics, to understand why stars have to be big enough to achieve this fusion process and also derive what would be the mass and radius of the smallest star that can fuse hydrogen.

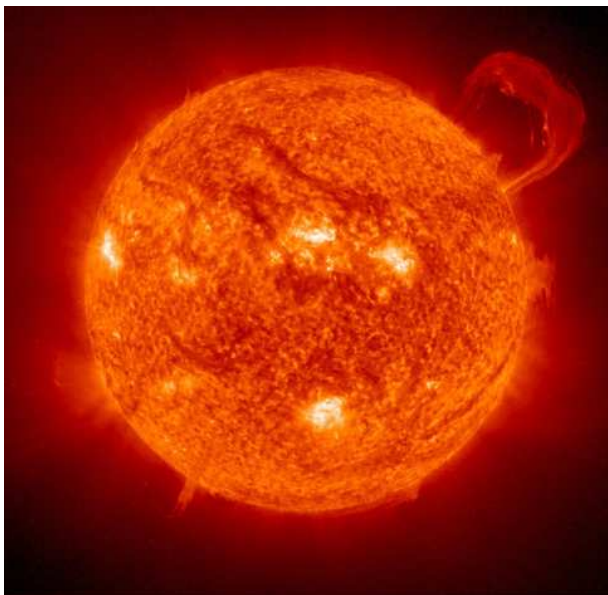

Figure 1. Our Sun, as most stars, shines as a result of thermonuclear fusion of hydrogen into helium in its central parts.

USEFUL CONSTANTS

Gravitational constant = $G = 6.7 \times 10^{-11} \text{ m}^3 \text{ kg}^{-1} \text{ s}^2$

Boltzmann's constant = $k = 1.4 \times 10^{-23} \text{ J K}^{-1}$

Planck's constant = $h = 6.6 \times 10^{-34} \text{ m}^2 \text{ kg s}^{-1}$

Mass of the proton = $m_p = 1.7 \times 10^{-27} \text{ kg}$

Mass of the electron = $m_e = 9.1 \times 10^{-31} \text{ kg}$

Unit of electric charge = $q = 1.6 \times 10^{-19} \text{ C}$

Electric constant (vacuum permittivity) = $\epsilon_0 = 8.9 \times 10^{-12} \text{ C}^2 \text{ N}^{-1} \text{ m}^{-2}$

Radius of the Sun = $R_S = 7.0 \times 10^8 \text{ m}$

Mass of the Sun = $M_S = 2.0 \times 10^{30} \text{ kg}$

1. A classical estimate of the temperature at the center of the stars.

Assume that the gas that forms the star is pure ionized hydrogen (electrons and protons in equal amounts), and that it behaves like an ideal gas. From the classical point of view, to fuse two protons, they need to get as close as 10^{-15} m for the short range strong nuclear force, which is attractive, to become dominant. However, to bring them together they have to overcome first the repulsive action of Coulomb's force. Assume classically that the two protons (taken to be point sources) are moving in an antiparallel way, each with velocity v_{rms} , the root-mean-square (rms) velocity of the protons, in a one-dimensional frontal collision.

1a	What has to be the temperature of the gas, T_c , so that the distance of closest approach of the protons, d_c , equals 10^{-15} m? Give this and all numerical values in this problem up to two significant figures.	1.5
----	--	-----

2. Finding that the previous temperature estimate is wrong.

To check if the previous temperature estimate is reasonable, one needs an independent way of estimating the central temperature of a star. The structure of the stars is very complicated, but we can gain significant understanding making some assumptions. Stars are in equilibrium, that is, they do not expand or contract because the inward force of gravity is balanced by the outward force of pressure (see Figure 2). For a slab of gas the equation of hydrostatic equilibrium at a given distance r from the center of the star, is given by

$$\frac{\Delta P}{\Delta r} = -\frac{GM_r \rho_r}{r^2},$$

where P is the pressure of the gas, G the gravitational constant, M_r the mass of the star within a sphere of radius r , and ρ_r is the density of the gas in the slab.

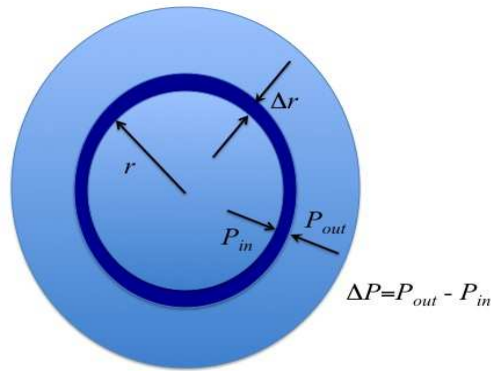

Figure 2. The stars are in hydrostatic equilibrium, with the pressure difference balancing gravity.

An order of magnitude estimate of the central temperature of the star can be obtained with values of the parameters at the center and at the surface of the star, making the following approximations:

$$\Delta P \approx P_o - P_c,$$

where P_c and P_o are the pressures at the center and surface of the star, respectively.

Since $P_c \gg P_o$, we can assume that

$$\Delta P \approx -P_c.$$

Within the same approximation, we can write

$$\Delta r \approx R,$$

where R is the total radius of the star, and

$$M_r \approx M_R = M,$$

with M the total mass of the star.

The density may be approximated by its value at the center,

$$\rho_r \approx \rho_c.$$

You can assume that the pressure is that of an ideal gas.

2a	Find an equation for the temperature at the center of the star, T_c , in terms of the radius and mass of the star and of physical constants only.	0.5
----	---	-----

We can use now the following prediction of this model as a criterion for its validity:

2b	Using the equation found in (2a) write down the ratio M/R expected for a star in terms of physical constants and T_c only.	0.5
2c	Use the value of T_c derived in section (1a) and find the numerical value of the ratio M/R expected for a star.	0.5
2d	Now, calculate the ratio $M(Sun)/R(Sun)$, and verify that this value is much smaller than the one found in (2c).	0.5

3. A quantum mechanical estimate of the temperature at the center of the stars

The large discrepancy found in (2d) suggests that the classical estimate for T_c obtained in (1a) is not correct. The solution to this discrepancy is found when we consider quantum mechanical effects, that tell us that the protons behave as waves and that a single proton is smeared on a size of the order of λ_p , the de Broglie wavelength. This implies that if d_c , the distance of closest approach of the protons is of the order of λ_p , the protons in a quantum mechanical sense overlap and can fuse.

3a	Assuming that $d_c = \frac{\lambda_p}{2^{1/2}}$ is the condition that allows fusion, for a proton with velocity v_{rms} , find an equation for T_c in terms of physical constants only.	1.0
3b	Evaluate numerically the value of T_c obtained in (3a).	0.5
3c	Use the value of T_c derived in (3b) to find the numerical value of the ratio M/R expected for a star, using the formula derived in (2b). Verify that this value is quite similar to the ratio $M(Sun)/R(Sun)$ observed.	0.5

Indeed, stars in the so-called *main sequence* (fusing hydrogen) approximately do follow this ratio for a large range of masses.

4. The mass/radius ratio of the stars.

The previous agreement suggests that the quantum mechanical approach for estimating the temperature at the center of the Sun is correct.

4a	Use the previous results to demonstrate that for any star fusing hydrogen, the ratio of mass M to radius R is the same and depends only on physical constants. Find the equation for the ratio M / R for stars fusing hydrogen.	0.5
----	---	-----

5. The mass and radius of the smallest star.

The result found in (4a) suggests that there could be stars of any mass as long as such a relationship is fulfilled; however, this is not true.

The gas inside normal stars fusing hydrogen is known to behave approximately as an ideal gas. This means that d_e , the typical separation *between electrons* is on the average larger than λ_e , their typical de Broglie wavelength. If closer, the electrons would be in a so-called degenerate state and the stars would behave differently. Note the distinction in the ways we treat protons and electrons inside the star. For protons, their de Broglie waves should overlap closely as they collide in order to fuse, whereas for electrons their de Broglie waves should not overlap in order to remain as an ideal gas.

The density in the stars increases with decreasing radius. Nevertheless, for this order-of-magnitude estimate assume they are of uniform density. You may further use that $m_p \gg m_e$.

5a	Find an equation for n_e , the average electron number density inside the star.	0.5
----	---	-----

5b	Find an equation for d_e , the typical separation between electrons inside the star.	0.5
----	--	-----

5c	Use the $d_e \geq \frac{\lambda_e}{2^{1/2}}$ condition to write down an equation for the radius of the smallest normal star possible. Take the temperature at the center of the star as typical for all the stellar interior.	1.5
----	---	-----

5d	Find the numerical value of the radius of the smallest normal star possible, both in meters and in units of solar radius.	0.5
----	---	-----

5e	Find the numerical value of the mass of the smallest normal star possible, both in kg and in units of solar masses.	0.5
----	---	-----

6. Fusing helium nuclei in older stars.

As stars get older they will have fused most of the hydrogen in their cores into helium (He), so they are forced to start fusing helium into heavier elements in order to continue shining. A helium nucleus has two protons and two neutrons, so it has twice the charge and approximately four times the mass of a proton. We saw before that $d_c = \frac{\lambda_p}{2^{1/2}}$ is the condition for the protons to fuse.

6a	Set the equivalent condition for helium nuclei and find $v_{rms}(He)$, the rms velocity of the helium nuclei and $T(He)$, the temperature needed for helium fusion.	0.5
----	---	-----

Answer Form
Theoretical Problem No. 3
Why are stars so large?

1) A first, classic estimate of the temperature at the center of the stars.

1a		1.5
----	--	-----

2) Finding that the previous temperature estimate is wrong.

2a		0.5
----	--	-----

2b		0.5
----	--	-----

2c		0.5
----	--	-----

2d		0.5
----	--	-----

3) A quantum mechanical estimate of the temperature at the center of the stars

3a		1.0
----	--	-----

3b		0.5
----	--	-----

3c		0.5
----	--	-----

4) The mass/radius ratio of the stars.

4a		0.5
----	--	-----

5) *The mass and radius of the smallest star.*

5a		0.5
----	--	-----

5b		0.5
----	--	-----

5c		1.5
----	--	-----

5d		0.5
----	--	-----

5e		0.5
----	--	-----

6) *Fusing helium nuclei in older stars.*

6a		0.5
----	--	-----

IPhO2009

Experimental Competition
Wednesday, July 15, 2009

The experimental part of this Olympiad consists of two problems. In Problem 1 the aim is to measure the wavelength of a diode laser, and in Problem 2 the goal is to measure the birefringence of a material called mica.

Please read this first:

1. The total time available is 5 hours for the experimental competition.
2. Use only the pencils provided.
3. Use only the front side of the paper sheets.
4. Each problem is presented in the *question form*, marked with a **Q** in the upper left corner.
5. You *must* summarize the answers you have obtained in the *answer form*, marked with an **A** in the upper left corner.
6. In addition, there is a set of *working sheets*, marked with a **W** in the upper left corner, where you may write your calculations.
7. In addition, write down the *Problem Number* (1 or 2) on the top of the *answer forms* and *working sheets*.
8. Write on the working sheets of paper whatever you consider is required for the solution of the problem. Please use *as little text as possible*; express yourself primarily in equations, numbers, figures, and plots.
9. For each problem and each of the forms (question form, answer form and working sheets), fill in the boxes at the top of each sheet of paper used by writing your student number (*Student Number*), the progressive page number (*Page No.*) and the total number of pages used (*Total No. of Pages*). If you use some working sheets of paper for notes that you do not wish to be marked, do **not** destroy it. Instead, mark it with a large X across the entire working sheet and do **not** include it in your numbering.
10. At the end of the exam, arrange all sheets for each problem *in the following order*:
 - answer form (including graph paper for your plots).
 - used working sheets in order
 - the working sheets that you do not wish to be considered (marked with the large X)
 - unused working sheets
 - printed question form.Place the papers of each problem set inside the folder and leave everything on your desk. You are not allowed to take *any* sheets of paper out of the room nor any device of the experimental kit.
11. The devices and materials for the experiments are contained in **two** separate packing layers within the box. The photographs of the sets are in the next page. Some devices are LABELED. For each experiment check that all the material is in the box. **If during the experiments you find that any of the devices is not working properly, please ask for a replacement.**

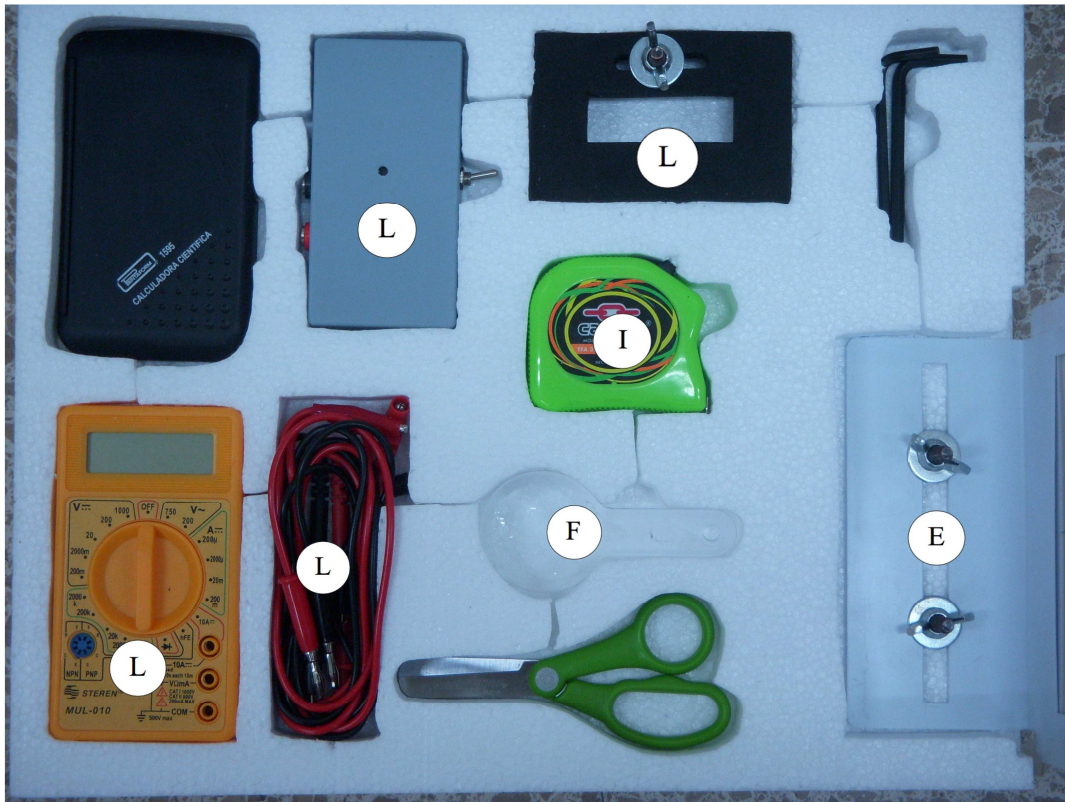
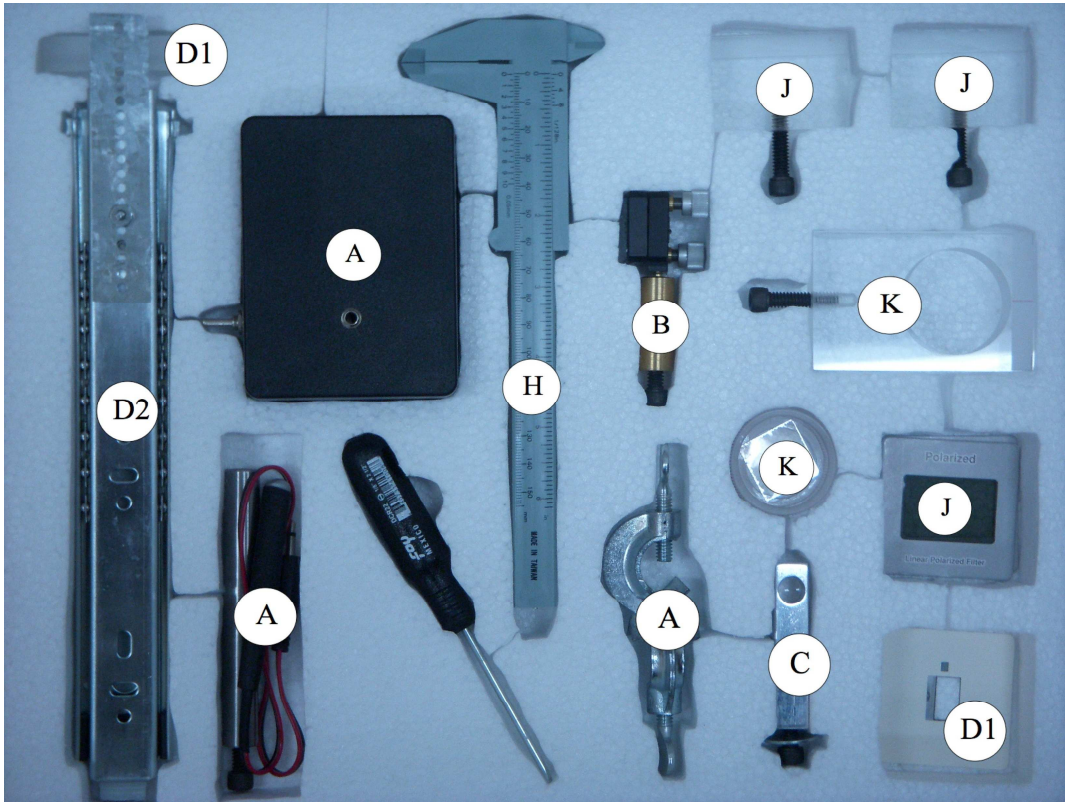

DIODE LASER EQUIPMENT AND MOVABLE MIRROR.

In both experimental setups you should need a diode laser, with its holder and power supply, and a mirror on a mechanical movable mount.

Before you decide on which problem to work first, we suggest that you mount the laser and the mirror, as indicated in Figure 0. Use the following material:

- 1) Wooden optical table.
- 2) Diode laser equipment. Includes the diode laser, support post, "S" clamp and power supply box (LABEL A). See photograph for mounting instructions. **DO NOT LOOK DIRECTLY INTO THE LASER BEAM.**
- 3) A mirror on a movable mount with two adjusting knobs and support post (LABEL B). See photograph for mounting instructions. **CAUTION: mount the support post to the optical table without touching the mirror. Take off the paper cover after you have mounted the mirror.**

Mount the above devices as indicated in Figure 0. The alignment of the laser beam will be done later on. NOTE: Although we have provided you with optional Allen wrenches, everything can be left fingertight.

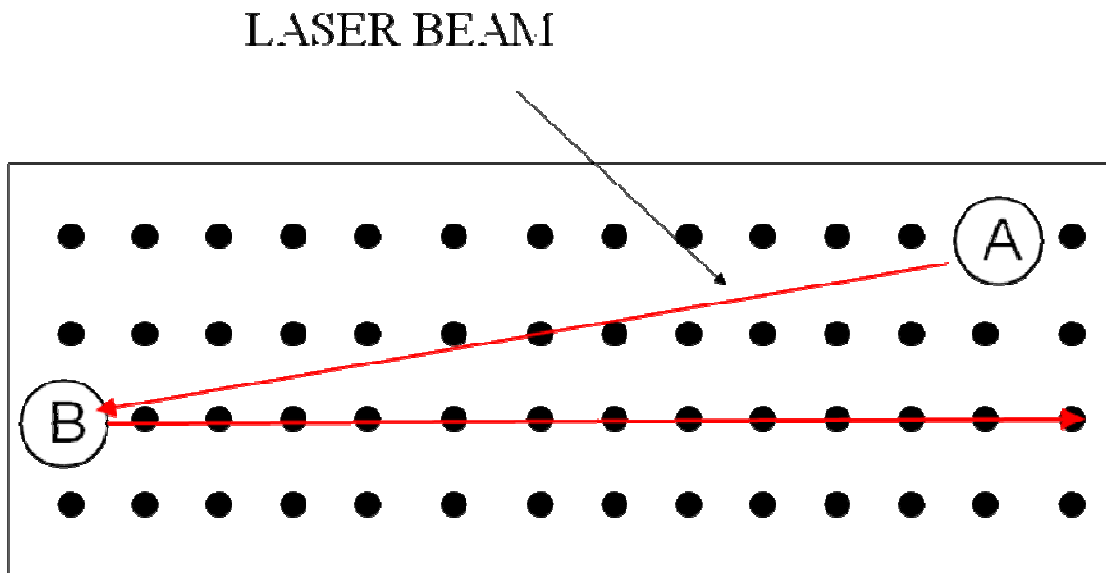
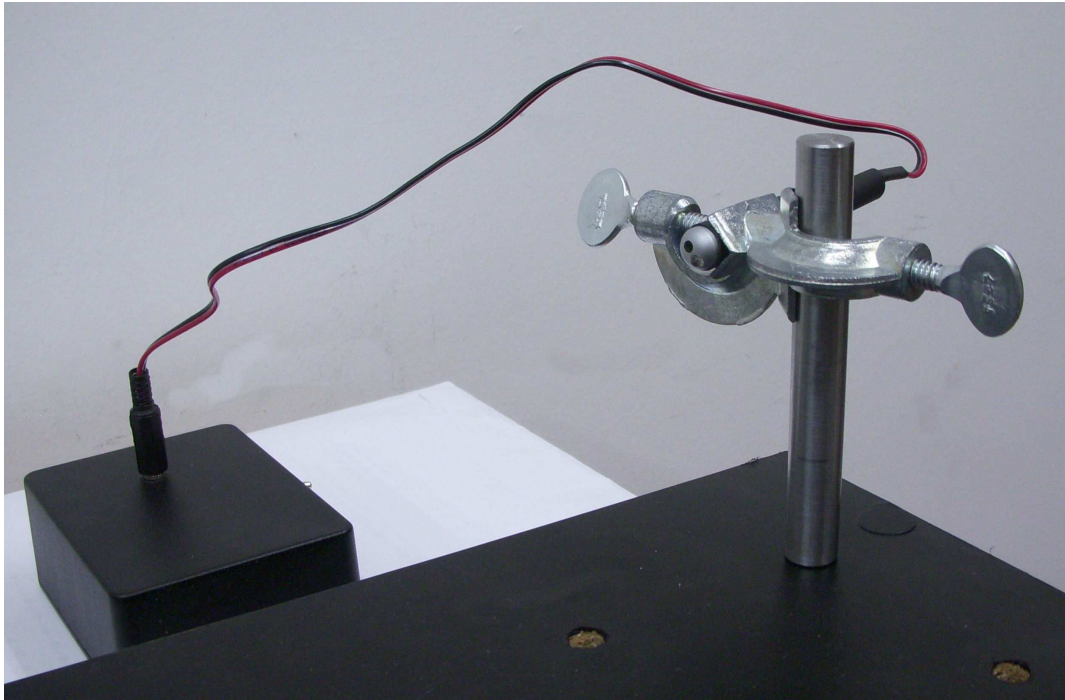
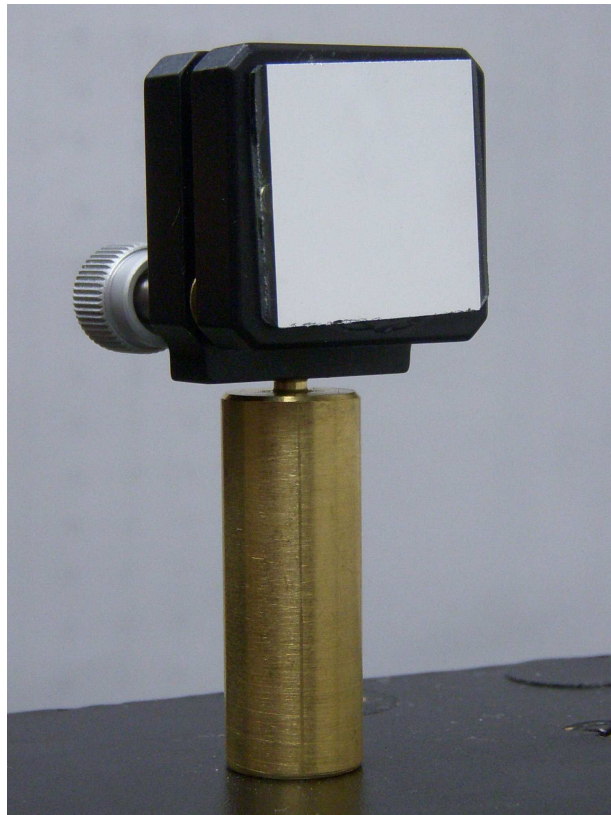

Figure 0. Mounting the laser and the mirror.



Diode laser, support post, "S" clamp and power supply box (LABEL A).



Mirror on a movable mount with two adjusting knobs and support post (LABEL B).

EXPERIMENTAL PROBLEM 1

DETERMINATION OF THE WAVELENGTH OF A DIODE LASER

MATERIAL

In addition to items 1), 2) and 3), you should use:

- 4) A lens mounted on a square post (LABEL C).
- 5) A razor blade in a slide holder to be placed in acrylic support, (LABEL D1) and mounted on sliding rail (LABEL D2). Use the screwdriver to tighten the support if necessary. See photograph for mounting instructions.
- 6) An observation screen with a caliper scale (1/20 mm) (LABEL E).
- 7) A magnifying glass (LABEL F).
- 8) 30 cm ruler (LABEL G).
- 9) Caliper (LABEL H).
- 10) Measuring tape (LABEL I).
- 11) Calculator.
- 12) White index cards, masking tape, stickers, scissors, triangle squares set.
- 13) Pencils, paper, graph paper.

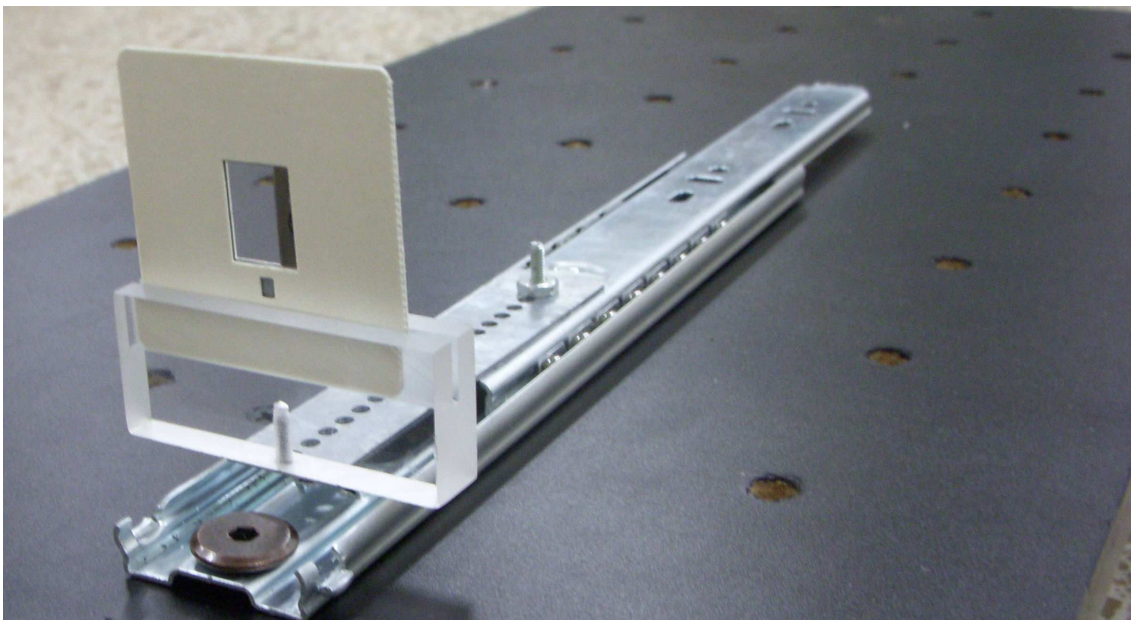

Razor blade in a slide holder to be placed in acrylic support (LABEL D1) and mounted on sliding rail (LABEL D2).

EXPERIMENT DESCRIPTION

You are asked to determine a diode laser wavelength. The particular feature of this measurement is that no exact micrometer scales (such as prefabricated diffraction gratings) are used. The smallest lengths measured are in the millimetric range. The wavelength is determined using light diffraction on a sharp edge of a razor blade.

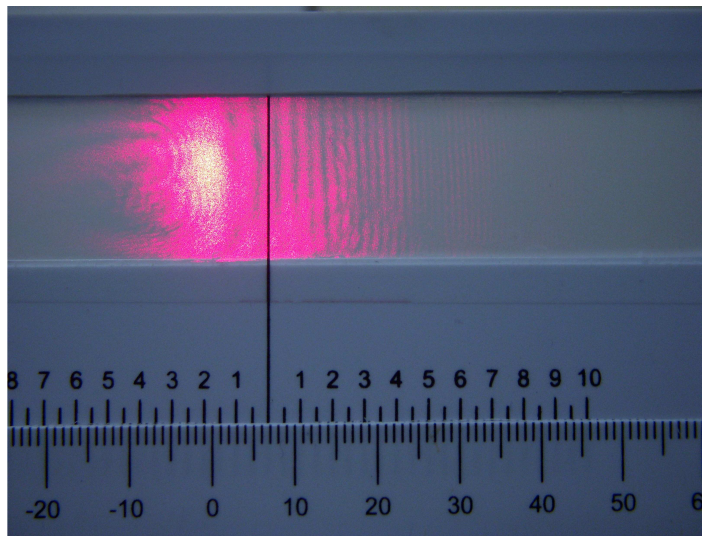

Figure 1.1 Typical interference fringe pattern.

Once the laser beam (A) is reflected on the mirror (B), it must be made to pass through a lens (C), which has a focal length of *a few centimeters*. It can now be assumed that the focus is a light point source from which a spherical wave is emitted. After the lens, and along its path, the laser beam hits a sharp razor blade edge as an obstacle. This can be considered to be a light source from which a cylindrical wave is emitted. These two waves interfere with each other, in the forward direction, creating a diffractive pattern that can be observed on a screen. See Figure 1.1 with a photograph of a typical pattern.

There are two important cases, see Figures 1.2 and 1.3.

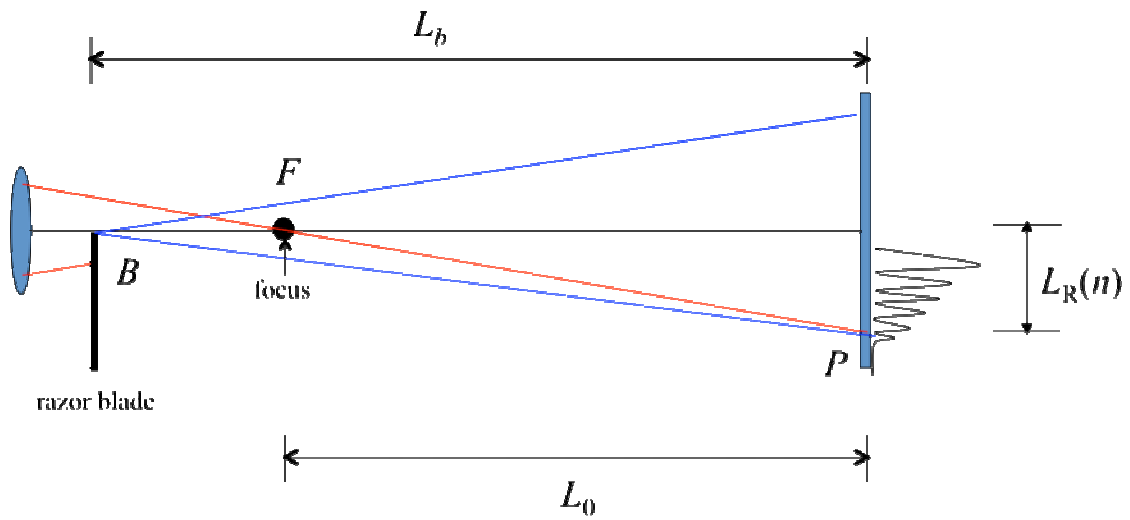

Figure 1.2. Case (I). The razor blade is *before* the focus of the lens. Figure is not at scale. B in this diagram is the edge of the blade and F is the focal point.

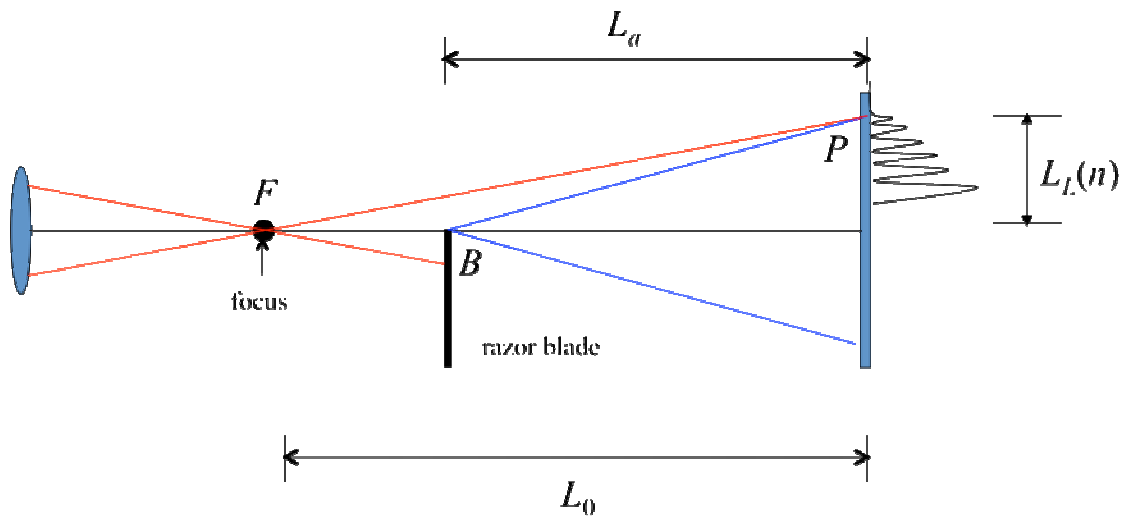

Figure 1.3. Case (II). The razor blade is *after* the focus of the lens. Figure is not at scale. B in this diagram is the edge of the blade and F is the focal point.

EXPERIMENTAL SETUP

Task 1.1 Experimental setup (1.0 points). Design an experimental setup to obtain the above described interference patterns. The distance L_0 from the focus to the screen should be much larger than the focal length.

- Make a sketch of your experimental setup in the drawing of the optical table provided. Do this by writing the LABELS of the different devices on the drawing of the optical table. You can make additional simple drawings to help clarify your design.
- You may align the laser beam by using one of the white index cards to follow the path.
- Make a sketch of the laser beam path on the drawing of the optical table and write down the height h of the beam as measured from the optical table.

WARNING: Ignore the larger circular pattern that may appear. This is an effect due to the laser diode itself.

Spend some time familiarizing yourself with the setup. You should be able to see of the order of 10 or more vertical linear fringes on the screen. The readings are made using the positions of the **dark** fringes. You may use the magnifying glass to see more clearly the position of the fringes. **The best way to observe the fringes is to look at the back side of the illuminated screen (E).** Thus, the scale of the screen should face out of the optical table. If the alignment of the optical devices is correct, you should see both patterns (of Cases I and II) by simply sliding the blade (D1) through the rail (D2).

THEORETICAL CONSIDERATIONS

Refer to Figure 1.2 and 1.3 above. There are five basic lengths:

L_0 : distance from the focus to the screen.

L_b : distance from the razor blade to the screen, Case I.

L_a : distance from the razor blade to the screen, Case II.

$L_R(n)$: position of the n -th **dark** fringe for Case I.

$L_L(n)$: position of the n -th **dark** fringe for Case II.

The first dark fringe, for both Cases I and II, is the widest one and corresponds to $n = 0$.

Your experimental setup must be such that $L_R(n) \ll L_0, L_b$ for Case I and $L_L(n) \ll L_0, L_a$ for Case II.

The phenomenon of wave interference is due to the difference in optical paths of a wave starting at the same point. Depending on their phase difference, the waves may cancel each

other (destructive interference) giving rise to dark fringes; or the waves may add (constructive interference) yielding bright fringes.

A detailed analysis of the interference of these waves gives rise to the following condition to obtain a **dark** fringe, for Case I:

$$\Delta_I(n) = \left(n + \frac{5}{8} \right) \lambda \quad \text{with } n = 0, 1, 2, \dots \quad (1.1)$$

and for Case II:

$$\Delta_{II}(n) = \left(n + \frac{7}{8} \right) \lambda \quad \text{with } n = 0, 1, 2, \dots \quad (1.2)$$

where λ is the wavelength of the laser beam, and Δ_I and Δ_{II} are the optical path differences for each case.

The difference in optical paths for Case I is,

$$\Delta_I(n) = (BF + FP) - BP \quad \text{for each } n = 0, 1, 2, \dots \quad (1.3)$$

while for Case II is,

$$\Delta_{II}(n) = (FB + BP) - FP \quad \text{for each } n = 0, 1, 2, \dots \quad (1.4)$$

Task 1.2 Expressions for optical paths differences (0.5 points). Assuming $L_R(n) \ll L_0, L_b$ for Case I and $L_L(n) \ll L_0, L_a$ for Case II in equations (1.3) and (1.4) (make sure your setup satisfies these conditions), find approximated expressions for $\Delta_I(n)$ and $\Delta_{II}(n)$ in terms of $L_0, L_b, L_a, L_R(n)$ and $L_L(n)$. You may find useful the approximation $(1+x)^r \approx 1+rx$ if $x \ll 1$.

The experimental difficulty with the above equations is that $L_0, L_R(n)$ and $L_L(n)$ cannot be accurately measured. The first one because it is not easy to find the position of the focus of the lens, and the two last ones because the origin from which they are defined may be very hard to find due to misalignments of your optical devices.

To solve the difficulties with $L_R(n)$ and $L_L(n)$, first choose the zero (0) of the scale of the screen (LABEL E) as the origin for all your measurements of the fringes. Let l_{0R} and l_{0L} be the (unknown) positions from which $L_R(n)$ and $L_L(n)$ are defined. Let $l_R(n)$ and $l_L(n)$ be the positions of the fringes as measured from the origin (0) you chose. Therefore

$$L_R(n) = l_R(n) - l_{0R} \quad \text{and} \quad L_L(n) = l_L(n) - l_{0L} \quad (1.5)$$

PERFORMING THE EXPERIMENT. DATA ANALYSIS.

Task 1.3 Measuring the dark fringe positions and locations of the blade (3.25 points).

- For both Case I and Case II, measure the positions of the dark fringes $l_R(n)$ and $l_L(n)$ as a function of the number fringe n . Write down your measurements in Table I; you should report no less than 8 measurements for each case.
- Report also the positions of the blade L_b and L_a , and indicate with its LABEL the instrument you used.
- **IMPORTANT SUGGESTION:** For purposes of both simplification of analysis and better accuracy, measure *directly* the distance $d = L_b - L_a$ with a better accuracy than that of L_b and L_a ; that is, do not calculate it from the measurements of L_b and L_a . Indicate with its LABEL the instrument you used.

Make sure that you include the uncertainty of your measurements.

Task 1.4 Data analysis. (3.25 points). With all the previous information you should be able to find out the values of l_{0R} and l_{0L} , and, of course, of the wavelength λ .

- Devise a procedure to obtain those values. Write down the expressions and/or equations needed.
- Include the analysis of the errors. You may use Table I or you can use another one to report your findings; make sure that you label clearly the contents of the columns of your tables.
- Plot the variables analyzed. Use the graph paper provided.
- Write down the values for l_{0R} and l_{0L} , with uncertainties.

Task 1.5 Calculating λ . Write down the calculated value for λ . Include its uncertainty and the analysis to obtain it. **SUGGESTION:** In your formula for λ , wherever you find $(L_b - L_a)$ replace it by d and use its measured value. **(2 points).**

Answer Form
Experimental Problem No. 1
Diode laser wavelength

Task 1.1 Experimental setup.

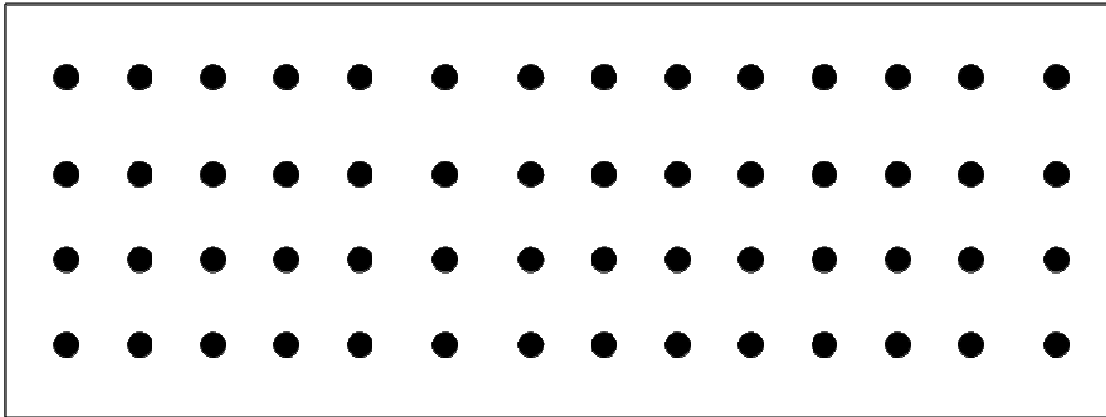

1.1	Sketch the laser path in drawing and write down the height h of the beam as measured from the table $h =$	1.0
-----	--	-----

Task 1.2 Expressions for optical path differences.

1.2		0.5
-----	--	-----

1.3	<p>Report positions of the blade and label of instrument:</p> $L_b =$ LABEL: $L_a =$ LABEL: $d = L_b - L_a =$ LABEL:	3.25
-----	---	------

Task 1.4 Performing a statistical and graphical analysis.

1.4		3.25
-----	--	------

Task 1.5 Calculating λ .

1.5	Write down the value of λ . $\lambda =$	2
-----	--	---

EXPERIMENTAL PROBLEM 2 BIREFRINGENCE OF MICA

In this experiment you will measure the birefringence of mica (a crystal widely used in polarizing optical components).

MATERIAL

In addition to items 1), 2) and 3), you should use,

- 14) Two polarizing films mounted in slide holders, each with an additional acrylic support (LABEL J). See photograph for mounting instructions.
- 15) A thin mica plate mounted in a plastic cylinder with a scale with no numbers; acrylic support for the cylinder (LABEL K). See photograph for mounting instructions.
- 16) Photodetector equipment. A photodetector in a plastic box, connectors and foam support. A multimeter to measure the voltage of the photodetector (LABEL L). See photograph for mounting and connecting instructions.
- 17) Calculator.
- 18) White index cards, masking tape, stickers, scissors, triangle squares set.
- 19) Pencils, paper, graph paper.



Polarizer mounted in slide holder with acrylic support (LABEL J).

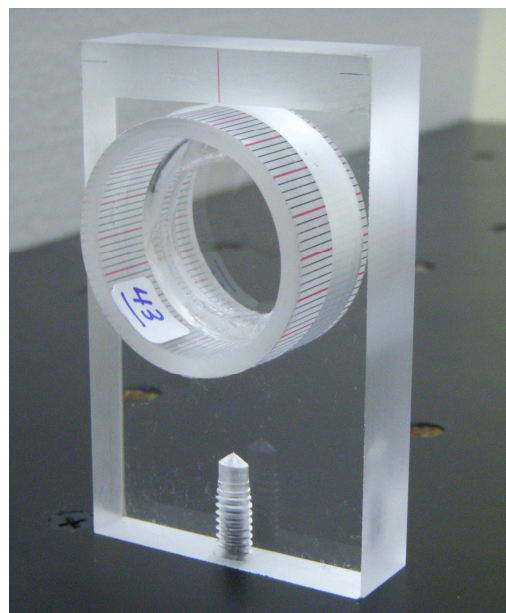

Thin mica plate mounted in cylinder with a scale with no numbers, and acrylic support (LABEL K).

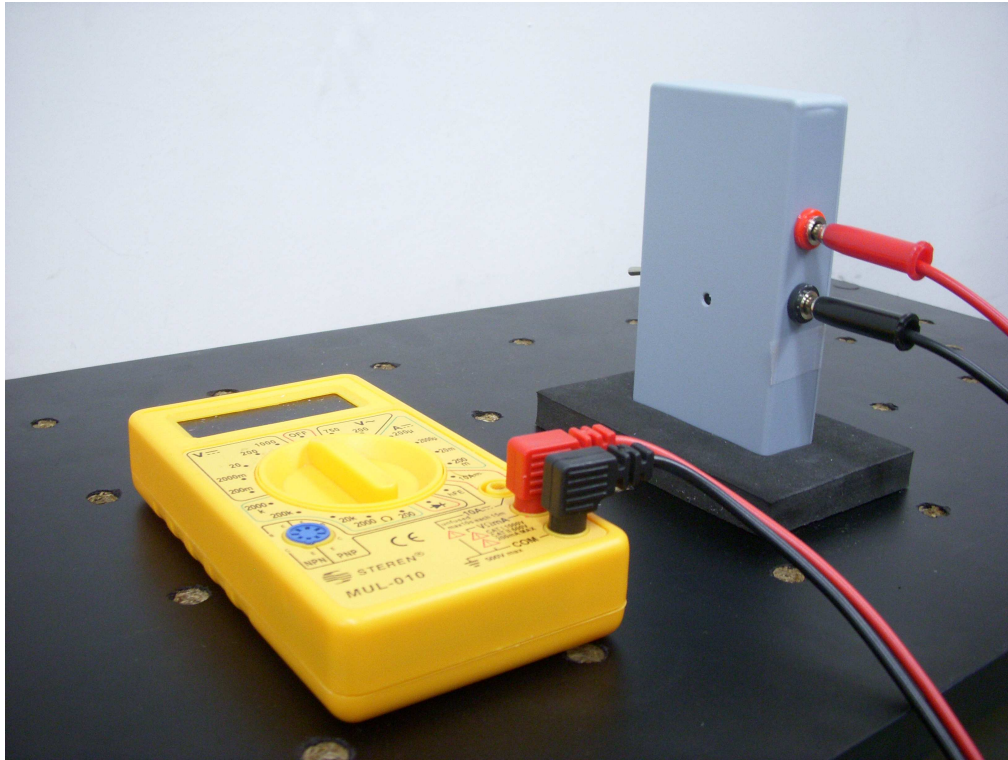

A photodetector in a plastic box, connectors and foam support. A multimeter to measure the voltage of the photodetector (LABEL L). Set the connections as indicated.

DESCRIPTION OF THE PHENOMENON

Light is a transverse electromagnetic wave, with its electric field lying on a plane perpendicular to the propagation direction and oscillating in time as the light wave travels.

If the direction of the electric field remains in time oscillating *along a single line*, the wave is said to be linearly polarized, or simply, polarized. See Figure 2.1.

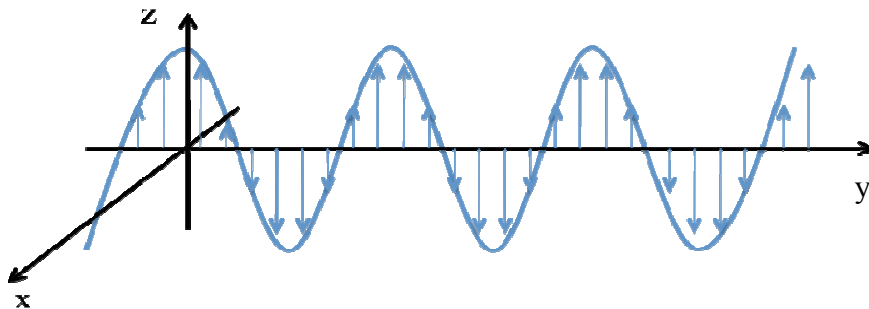

Figure 2.1 A wave travelling in the y-direction and polarized in the z-direction.

A polarizing film (or simply, a polarizer) is a material with a privileged axis parallel to its surface, such that, transmitted light emerges polarized along the axis of the polarizer. Call (+) the privileged axis and (-) the perpendicular one.

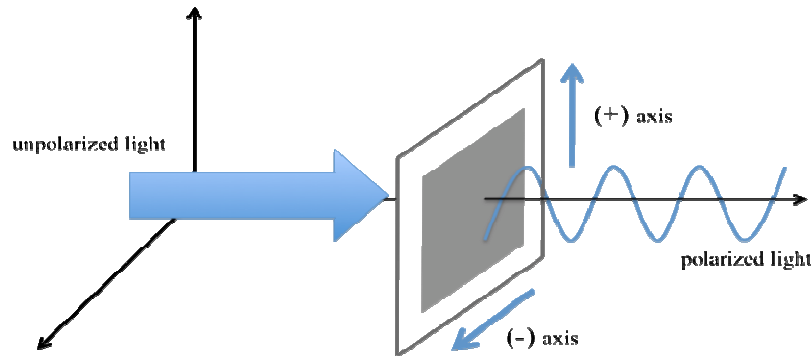

Figure 2.2 Unpolarized light normally incident on a polarizer. Transmitted light is polarized in the (+) direction of the polarizer.

Common transparent materials (such as window glass), transmit light with the same polarization as the incident one, because its index of refraction does not depend on the direction and/or polarization of the incident wave. Many crystals, including mica, however, are sensitive to the direction of the electric field of the wave. For propagation perpendicular to its surface, the mica sheet has two characteristic orthogonal axes, which we will call Axis 1 and Axis 2. This leads to the phenomenon called birefringence.

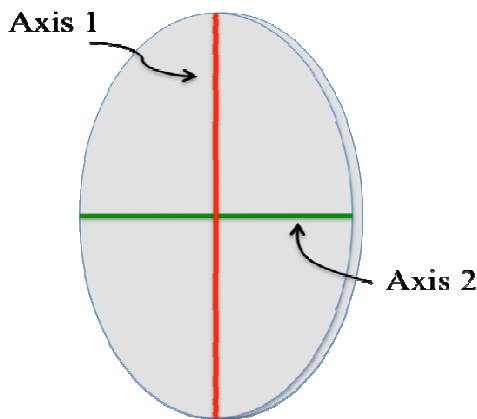

Figure 2.3 Thin slab of mica with its two axes, Axis 1 (red) and Axis 2 (green).

Let us analyze two simple cases to exemplify the birefringence. Assume that a wave **polarized in the vertical direction** is normally incident on one of the surfaces of the thin slab of mica.

Case 1) Axis 1 or Axis 2 is parallel to the polarization of the incident wave. The transmitted wave passes without changing its polarization state, but the propagation is characterized as if the material had either an index of refraction n_1 or n_2 . See Figs. 2.4 and 2.5.

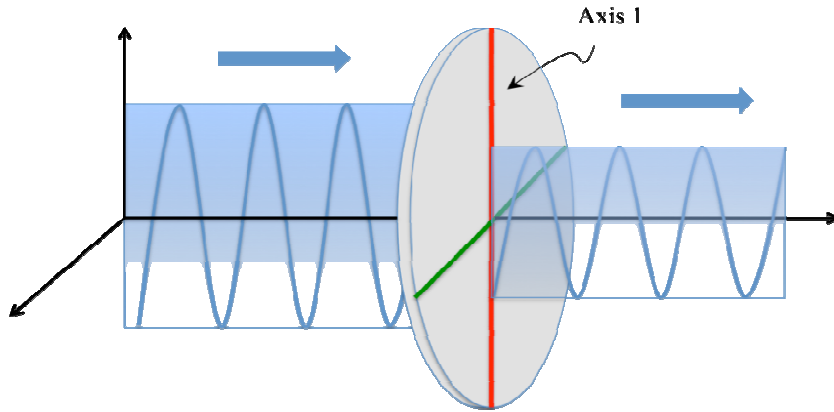

Figure 2.4 Axis 1 is parallel to polarization of incident wave. Index of refraction is n_1 .

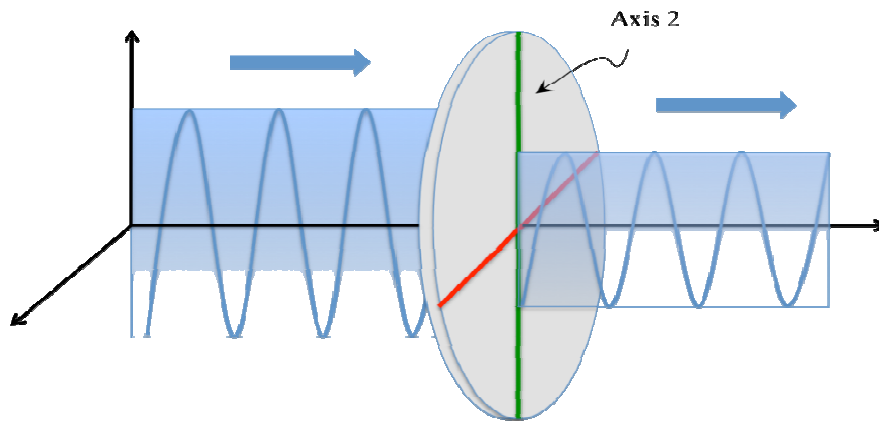

Figure 2.5 Axis 2 is parallel to polarization of incident wave. Index of refraction is n_2 .

Case 2) Axis 1 makes an angle θ with the direction of polarization of the incident wave. The transmitted light has a more complicated polarization state. This wave, however, can be seen as the *superposition* of two waves with different phases, one that has polarization **parallel** to the polarization of the incident wave (i.e. "vertical") and another that has polarization **perpendicular** to the polarization of the incident wave (i.e. "horizontal").

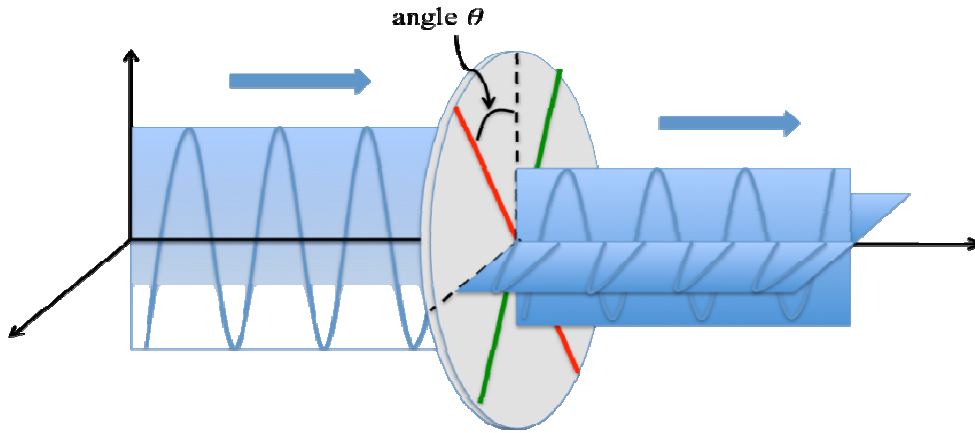

Figure 2.6 Axis 1 makes an angle θ with polarization of incident wave

Call I_p the *intensity* of the wave transmitted *parallel* to the polarization of the incident wave, and I_o the *intensity* of the wave transmitted *perpendicular* to polarization of the incident wave. These intensities depend on the angle θ , on the wavelength λ of the light source, on the thickness L of the thin plate, and on the absolute value of the difference of the refractive indices, $|n_1 - n_2|$. This last quantity is called the *birefringence* of the material. The measurement of this quantity is the goal of this problem. Together with polarizers, birefringent materials are useful for the control of light polarization states.

We point out here that the photodetector measures the intensity of the light incident on it, independent of its polarization.

The dependence of $I_p(\theta)$ and $I_o(\theta)$ on the angle θ is complicated due to other effects not considered, such as the absorption of the incident radiation by the mica. One can obtain, however, approximated but very simple expressions for the normalized intensities $\bar{I}_p(\theta)$ and $\bar{I}_o(\theta)$, defined as,

$$\bar{I}_p(\theta) = \frac{I_p(\theta)}{I_p(\theta) + I_o(\theta)} \quad (2.1)$$

and

$$\bar{I}_o(\theta) = \frac{I_o(\theta)}{I_p(\theta) + I_o(\theta)} \quad (2.2)$$

It can be shown that the normalized intensities are (approximately) given by,

$$\bar{I}_p(\theta) = 1 - \frac{1}{2}(1 - \cos \Delta\phi) \sin^2(2\theta) \quad (2.3)$$

and

$$\bar{I}_o(\theta) = \frac{1}{2}(1 - \cos\Delta\phi)\sin^2(2\theta) \quad (2.4)$$

where $\Delta\phi$ is the difference of phases of the parallel and perpendicular transmitted waves. This quantity is given by,

$$\Delta\phi = \frac{2\pi L}{\lambda}|n_1 - n_2| \quad (2.5)$$

where L is the thickness of the thin plate of mica, λ the wavelength of the incident radiation and $|n_1 - n_2|$ the birefringence.

EXPERIMENTAL SETUP

Task 2.1 Experimental setup for measuring intensities. Design an experimental setup for measuring the intensities I_p and I_o of the transmitted wave, as a function of the angle θ of any of the optical axes, as shown in Fig. 2.6. *Do this by writing the LABELS of the different devices on the drawing of the optical table.* Use the convention (+) and (-) for the direction of the polarizers. You can make additional simple drawings to help clarify your design.

Task 2.1 a) Setup for I_p **(0.5 points).**

Task 2.1 b) Setup for I_o **(0.5 points).**

Laser beam alignment. Align the laser beam in such a way that it is parallel to the table and is incident on the center of the cylinder holding the mica. You may align by using one the white index cards to follow the path. Small adjustments can be made with the movable mirror.

Photodetector and the multimeter. The photodetector produces a voltage as light impinges on it. Measure this voltage with the multimeter provided. The voltage produced is linearly proportional to the intensity of the light. Thus, report the intensities as the voltage produced by the photodetector. Without any laser beam incident on the photodetector, you can measure the background light intensity of the detector. This should be less than 1 mV. *Do not correct* for this background when you perform the intensity measurements.

WARNING: The laser beam is partially polarized but it is not known in which direction. Thus, to obtain polarized light with good intensity readings, place a polarizer with either its (+) or (-) axes vertically in such a way that you obtain the maximum transmitted intensity in the absence of any other optical device.

MEASURING INTENSITIES

Task 2.2 The scale for angle settings. The cylinder holding the mica has a regular graduation for settings of the angles. Write down the value in degrees of the smallest interval (*i.e.* between two black consecutive lines). **(0.25 points).**

Finding (approximately) the zero of θ and/or the location of the mica axes. To facilitate the analysis, it is very important that you find the appropriate zero of the angles. We suggest that, first, you identify the location of one of the mica axes, and call it Axis 1. It is almost sure that this position will not coincide with a graduation line on the cylinder. Thus, consider the nearest graduation line in the mica cylinder as the provisional origin for the angles. Call $\bar{\theta}$ the angles measured from such an origin. Below you will be asked to provide a more accurate location of the zero of θ .

Task 2.3 Measuring I_p and I_o . Measure the intensities I_p and I_o for as many angles $\bar{\theta}$ as you consider necessary. Report your measurements in Table I. Try to make the measurements for I_p and I_o for the *same* setting of the cylinder with the mica, that is, for a *fixed* angle $\bar{\theta}$. **(3.0 points).**

Task 2.4 Finding an appropriate zero for θ . The location of Axis 1 defines the zero of the angle θ . As mentioned above, it is mostly sure that the location of Axis 1 does not coincide with a graduation line on the mica cylinder. To find the zero of the angles, you may proceed either graphically or numerically. Recognize that the relationship near a maximum or a minimum may be approximated by a parabola where:

$$I(\bar{\theta}) \approx a\bar{\theta}^2 + b\bar{\theta} + c$$

and the minimum or maximum of the parabola is given by,

$$\bar{\theta}_m = -\frac{b}{2a}.$$

Either of the above choices gives rise to a shift $\delta\bar{\theta}$ of all your values of $\bar{\theta}$ given in Table I of Task 2.3, such that they can now be written as angles θ from the appropriate zero, $\theta = \bar{\theta} + \delta\bar{\theta}$. Write down the value of the shift $\delta\bar{\theta}$ in degrees. **(1.0 points).**

DATA ANALYSIS.

Task 2.5 Choosing the appropriate variables. Choose $\bar{I}_p(\theta)$ or $\bar{I}_o(\theta)$ to make an analysis to find the difference of phases $\Delta\phi$. Identify the variables that you will use. **(0.5 point).**

Task 2.6 Data analysis and the phase difference.

- Use Table II to write down the values of the variables needed for their analysis. Make sure that you use the corrected values for the angles θ . Include uncertainties. Use graph paper to plot your variables. **(1.0 points)**.
- Perform an analysis of the data needed to obtain the phase difference $\Delta\phi$. Report your results including uncertainties. Write down any equations or formulas used in the analysis. Plot your results. **(1.75 points)**.
- Calculate the value of the phase difference $\Delta\phi$ in radians, including its uncertainty. Find the value of the phase difference in the interval $[0, \pi]$. **(0.5 points)**.

Task 2.7 Calculating the birefringence $|n_1 - n_2|$. You may note that if you add $2N\pi$ to the phase difference $\Delta\phi$, with N any integer, or if you change the sign of the phase, the values of the intensities are unchanged. However, the value of the birefringence $|n_1 - n_2|$ would change. Thus, to use the value $\Delta\phi$ found in Task 2.6 to correctly calculate the birefringence, you must consider the following:

$$\Delta\phi = \frac{2\pi L}{\lambda} |n_1 - n_2| \quad \text{if} \quad L < 82 \times 10^{-6} \text{ m}$$

or

$$2\pi - \Delta\phi = \frac{2\pi L}{\lambda} |n_1 - n_2| \quad \text{if} \quad L > 82 \times 10^{-6} \text{ m}$$

where the value L of the thickness of the slab of mica you used is written on the cylinder holding it. This number is given in micrometers (1 micrometer = 10^{-6} m). Assign 1×10^{-6} m as the uncertainty for L . For the laser wavelength, you may use the value you found in Problem 1 or the average value between 620×10^{-9} m and 750×10^{-9} m, the reported range for red in the visible spectrum. Write down the values of L and λ as well as the birefringence $|n_1 - n_2|$ with its uncertainty. Include the formulas that you used to calculate the uncertainties. **(1.0 points)**.

Answer Form
Experimental Problem No. 2
Birefringence of mica

Task 2.1 a) Experimental setup for I_p . (0.5 points)

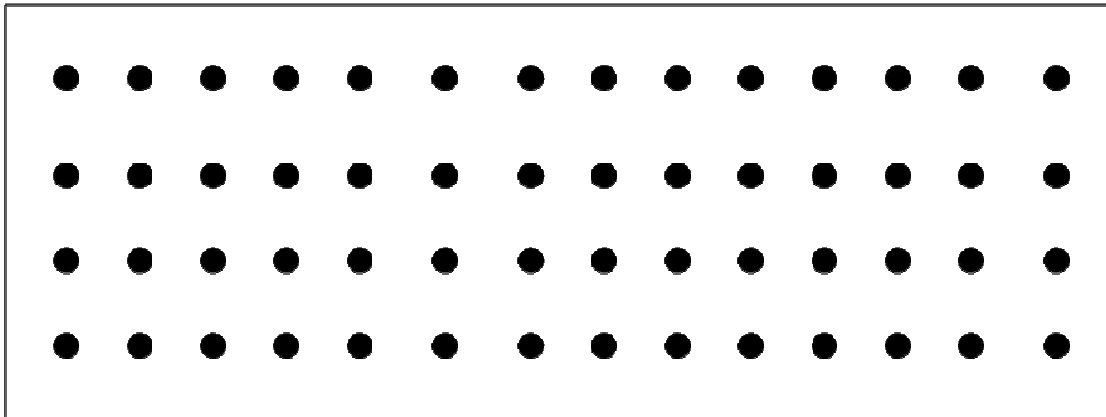

Task 2.1 b) Experimental setup for I_o . (0.5 points)

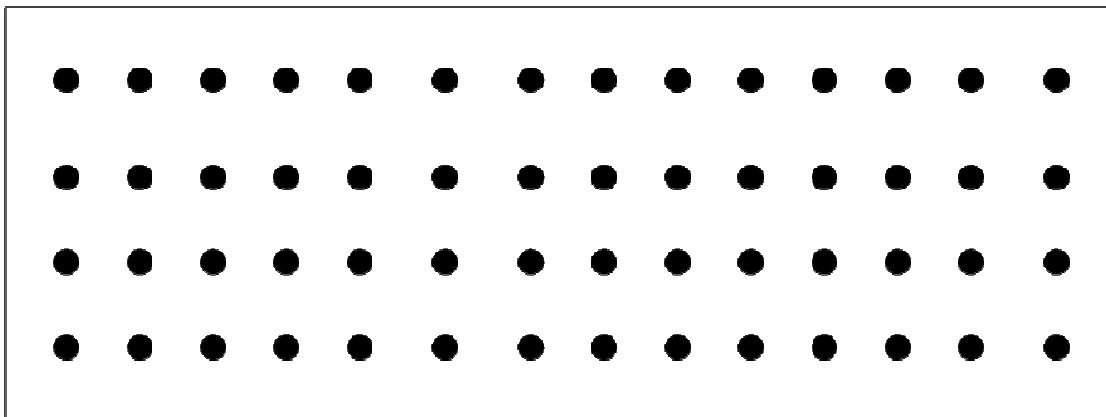

2.1		1.0
-----	--	-----

Task 2.4 Finding an appropriate zero for θ .

2.4		1.0
-----	--	-----

Task 2.5 Choosing the appropriate variables.

2.5		0.5
-----	--	-----

Task 2.6 Statistical analysis and the phase difference.

2.6		3.25
-----	--	------

2.6

--	--	--

2.6		0.5
-----	--	-----

Task 2.7 Calculating the birefringence $|n_1 - n_2|$.

2.7	<p>Write down the width of the plate of mica you used,</p> <p>$L =$</p> <p>Write down the wavelength you use,</p> <p>$\lambda =$</p> <p>Calculate the birefringence</p> <p>$n_1 - n_2 =$</p> <p>Write down the formulas you used for the calculation of the uncertainty of the birefringence.</p>	1.0
-----	--	-----

THEORETICAL PROBLEM No. 1

EVOLUTION OF THE EARTH-MOON SYSTEM

SOLUTIONS

1. Conservation of Angular Momentum

1a	$L_1 = I_E \omega_{E1} + I_{M1} \omega_{M1}$	0.2
----	--	-----

1b	$L_2 = I_E \omega_2 + I_{M2} \omega_2$	0.2
----	--	-----

1c	$I_E \omega_{E1} + I_{M1} \omega_{M1} = I_{M2} \omega_2 = L_1$	0.3
----	--	-----

2. Final Separation and Angular Frequency of the Earth-Moon System.

2a	$\omega_2^2 D_2^3 = GM_E$	0.2
----	---------------------------	-----

2b	$D_2 = \frac{L_1^2}{GM_E M_M^2}$	0.5
----	----------------------------------	-----

2c	$\omega_2 = \frac{G^2 M_E^2 M_M^3}{L_1^3}$	0.5
----	--	-----

2d	<p>The moment of inertia of the Earth will be the addition of the moment of inertia of a sphere with radius r_o and density ρ_o and of a sphere with radius r_i and density $\rho_i - \rho_o$:</p> $I_E = \frac{2}{5} \frac{4\pi}{3} [r_o^5 \rho_o + r_i^5 (\rho_i - \rho_o)] .$	0.5
----	--	-----

2e	$I_E = \frac{2}{5} \frac{4\pi}{3} [r_o^5 \rho_o + r_i^5 (\rho_i - \rho_o)] = 8.0 \times 10^{37} \text{ kg m}^2$	0.2
----	---	-----

2f	$L_1 = I_E \omega_{E1} + I_{M1} \omega_{M1} = 3.4 \times 10^{34} \text{ kg m}^2 \text{ s}^{-1}$	0.2
----	---	-----

2g	$D_2 = 5.4 \times 10^8$ m, that is $D_2 = 1.4 D_1$	0.3
----	--	-----

2h	$\omega_2 = 1.6 \times 10^{-6} \text{ s}^{-1}$, that is, a period of 46 days.	0.3
----	--	-----

2i	Since $I_E \omega_2 = 1.3 \times 10^{32} \text{ kg m}^2 \text{ s}^{-1}$ and $I_{M_2} \omega_2 = 3.4 \times 10^{34} \text{ kg m}^2 \text{ s}^{-1}$, the approximation is justified since the final angular momentum of the Earth is 1/260 of that of the Moon.	0.2
----	--	-----

3. How much is the Moon receding per year?

3a	Using the law of cosines, the magnitude of the force produced by the mass m closest to the Moon will be: $F_c = \frac{G m M_M}{D_1^2 + r_o^2 - 2 D_1 r_o \cos(\theta)}$	0.4
----	--	-----

3b	Using the law of cosines, the magnitude of the force produced by the mass m farthest to the Moon will be: $F_f = \frac{G m M_M}{D_1^2 + r_o^2 + 2 D_1 r_o \cos(\theta)}$	0.4
----	---	-----

3c	Using the law of sines, the torque will be $\tau_c = F_c \frac{\sin(\theta) r_o D_1}{[D_1^2 + r_o^2 - 2 D_1 r_o \cos(\theta)]^{1/2}} = \frac{G m M_M \sin(\theta) r_o D_1}{[D_1^2 + r_o^2 - 2 D_1 r_o \cos(\theta)]^{3/2}}$	0.4
----	--	-----

3d	Using the law of sines, the torque will be $\tau_f = F_f \frac{\sin(\theta) r_o D_1}{[D_1^2 + r_o^2 + 2 D_1 r_o \cos(\theta)]^{1/2}} = \frac{G m M_M \sin(\theta) r_o D_1}{[D_1^2 + r_o^2 + 2 D_1 r_o \cos(\theta)]^{3/2}}$	0.4
----	--	-----

3e	$\tau_c - \tau_f = G m M_M \sin(\theta) r_o D_1^{-2} \left(1 - \frac{3r_o^2}{2D_1^2} + \frac{3r_o \cos(\theta)}{D_1} - 1 + \frac{3r_o^2}{2D_1^2} + \frac{3r_o \cos(\theta)}{D_1} \right)$ $= \frac{6 G m M_M r_o^2 \sin(\theta) \cos(\theta)}{D_1^3}$	1.0
----	---	-----

3f	$\tau = \frac{6GmM_M r_o^2 \sin(\theta)\cos(\theta)}{D_1^3} = 4.1 \times 10^{16} \text{ N m}$	0.5
----	---	-----

3g	<p>Since $\omega_{M1}^2 D_1^3 = GM_E$, we have that the angular momentum of the Moon is</p> $I_{M1} \omega_{M1} = M_M D_1^2 \left[\frac{GM_E}{D_1^3} \right]^{1/2} = M_M [D_1 GM_E]^{1/2}$ <p>The torque will be:</p> $\tau = \frac{M_M [GM_E]^{1/2} \Delta(D_1^{1/2})}{\Delta t} = \frac{M_M [GM_E]^{1/2} \Delta D_1}{2[D_1]^{1/2} \Delta t}$ <p>So, we have that</p> $\Delta D_1 = \frac{2 \tau \Delta t}{M_M} \left[\frac{D_1}{GM_E} \right]^{1/2}$ <p>That for $\Delta t = 3.1 \times 10^7 \text{ s} = 1 \text{ year}$, gives $\Delta D_1 = 0.034 \text{ m}$. This is the yearly increase in the Earth-Moon distance.</p>	1.0
----	--	-----

3h	<p>We now use that</p> $\tau = - \frac{I_E \Delta \omega_{E1}}{\Delta t}$ <p>from where we get</p> $\Delta \omega_{E1} = - \frac{\tau \Delta t}{I_E}$ <p>that for $\Delta t = 3.1 \times 10^7 \text{ s} = 1 \text{ year}$ gives</p> $\Delta \omega_{E1} = -1.6 \times 10^{-14} \text{ s}^{-1}$ <p>If P_E is the period of time considered, we have that:</p> $\frac{\Delta P_E}{P_E} = - \frac{\Delta \omega_{E1}}{\omega_E}$ <p>since $P_E = 1 \text{ day} = 8.64 \times 10^4 \text{ s}$, we get</p> $\Delta P_E = 1.9 \times 10^{-5} \text{ s}$ <p>This is the amount of time that the day lengthens in a year.</p>	1.0
----	--	-----

4. Where is the energy going?

4a	<p>The present total (rotational plus gravitational) energy of the system is:</p> $E = \frac{1}{2} I_E \omega_{E1}^2 + \frac{1}{2} I_M \omega_{M1}^2 - \frac{GM_E M_M}{D_1}$ <p>Using that</p> $\omega_{M1}^2 D_1^3 = GM_E$, we get	0.4
----	--	-----

	$E = \frac{1}{2} I_E \omega_{E1}^2 - \frac{1}{2} \frac{GM_E M_M}{D_1}$	
--	--	--

4b	$\Delta E = I_E \omega_{E1} \Delta \omega_{E1} + \frac{1}{2} \frac{GM_E M_M}{D_1^2} \Delta D_1, \text{ that gives}$ $\Delta E = -9.0 \times 10^{19} \text{ J}$	0.4
----	---	-----

4c	$M_{\text{water}} = 4\pi r_o^2 \times h \times \rho_{\text{water}} \text{ kg} = 2.6 \times 10^{17} \text{ kg.}$	0.2
----	---	-----

4d	$\Delta E_{\text{water}} = -g M_{\text{water}} \times 0.5 \text{ m} \times 2 \text{ day}^{-1} \times 365 \text{ days} \times 0.1 = -9.3 \times 10^{19} \text{ J.}$ Then, the two energy estimates are comparable.	0.3
----	---	-----

THEORETICAL PROBLEM 2

SOLUTION

DOPPLER LASER COOLING AND OPTICAL MOLASSES

The key to this problem is the Doppler effect (to be precise, the longitudinal Doppler effect): The frequency of a monochromatic beam of light detected by an observer depends on its state of motion relative to the emitter, i.e. the observed frequency is

$$\omega' = \omega \sqrt{\frac{1 \pm v/c}{1 \mp v/c}} \approx \omega \left(1 \pm \frac{v}{c}\right)$$

where v is the relative speed of emitter and observer and ω the frequency of the emitter. The upper-lower signs correspond, respectively, when source and observer move towards or away from each other. The second equality holds in the limit of low velocities (non-relativistic limit).

The frequency of the laser in the lab is ω_L ; ω_0 is the transition frequency of the atom; the atom moves with speed v towards the incident direction of the laser:

It is important to point out that the results must be given to first significant order in v/c or $\hbar q/mv$.

PART I: BASICS OF LASER COOLING

1. Absorption.

1a	Write down the resonance condition for the absorption of the photon. $\omega_0 \approx \omega_L \left(1 + \frac{v}{c}\right)$	0.2
1b	Write down the momentum p_{at} of the atom after absorption, as seen in the laboratory $p_{at} = p - \hbar q \approx mv - \frac{\hbar \omega_L}{c}$	0.2
1c	Write down the energy ε_{at} of the atom after absorption, as seen in the laboratory $\varepsilon_{at} = \frac{p_{at}^2}{2m} + \hbar \omega_0 \approx \frac{mv^2}{2} + \hbar \omega_L$	0.2

2. Spontaneous emission in the $-x$ direction.

First, one calculates the energy of the emitted photon, as seen in the lab reference frame. One must be careful to keep the correct order; this is because the velocity of the atom changes after the absorption, however, this is second order correction for the emitted frequency:

$$\omega_{ph} \approx \omega_0 \left(1 - \frac{v'}{c} \right) \quad \text{with} \quad v' \approx v - \frac{\hbar q}{m}$$

thus,

$$\begin{aligned} \omega_{ph} &\approx \omega_0 \left(1 - \frac{v}{c} + \frac{\hbar q}{mc} \right) \\ &\approx \omega_L \left(1 + \frac{v}{c} \right) \left(1 - \frac{v}{c} + \frac{\hbar q}{mc} \right) \\ &\approx \omega_L \left(1 + \frac{\hbar q}{mc} \right) \\ &\approx \omega_L \left(1 + \left(\frac{\hbar q}{mv} \right) \left(\frac{v}{c} \right) \right) \\ &\approx \omega_L \end{aligned}$$

2a	Write down the energy of the emitted photon, ε_{ph} , after the emission process in the $-x$ direction, as seen in the laboratory. $\varepsilon_{ph} \approx \hbar \omega_L$	0.2
----	---	-----

2b	Write down the momentum of the emitted photon p_{ph} , after the emission process in the $-x$ direction, as seen in the laboratory. $p_{ph} \approx -\hbar \omega_L / c$	0.2
----	---	-----

Use conservation of momentum (see 1b):

$$p_{at} + p_{ph} \approx p - \hbar q$$

2c	Write down the momentum of the atom p_{at} , after the emission process in the $-x$ direction, as seen in the laboratory. $p_{at} \approx p = mv$	0.2
----	--	-----

2d	Write down the energy of the atom ε_{at} , after the emission process in the $-x$ direction, as seen in the laboratory. $\varepsilon_{at} \approx \frac{p^2}{2m} = \frac{mv^2}{2}$	0.2
----	---	-----

3. Spontaneous emission in the $+x$ direction.

The same as in the previous questions, keeping the right order

3a	Write down the energy of the emitted photon, ε_{ph} , after the emission process in the $+x$ direction, as seen in the laboratory. $\varepsilon_{ph} \approx \hbar\omega_0 \left(1 + \frac{v}{c}\right) \approx \hbar\omega_L \left(1 + \frac{v}{c}\right) \left(1 + \frac{v}{c}\right) \approx \hbar\omega_L \left(1 + 2\frac{v}{c}\right)$	0.2
----	---	-----

3b	Write down the momentum of the emitted photon p_{ph} , after the emission process in the $+x$ direction, as seen in the laboratory. $p_{ph} \approx \frac{\hbar\omega_L}{c} \left(1 + 2\frac{v}{c}\right)$	0.2
----	---	-----

3c	Write down the momentum of the atom p_{at} , after the emission process in the $+x$ direction, as seen in the laboratory. $p_{at} = p - \hbar q - p_{ph} \approx p - \hbar q - \frac{\hbar\omega_L}{c} \left(1 + 2\frac{v}{c}\right) \approx mv - 2\frac{\hbar\omega_L}{c}$	0.2
----	--	-----

3d	Write down the energy of the atom ε_{at} , after the emission process in the $+x$ direction, as seen in the laboratory. $\varepsilon_{at} = \frac{p_{at}^2}{2m} \approx \frac{mv^2}{2} \left(1 - 2\frac{\hbar q}{mv}\right)$	0.2
----	---	-----

4. Average emission after absorption.

The spontaneous emission processes occur with equal probabilities in both directions.

4a	Write down the average energy of an emitted photon, ε_{ph} , after the emission process. $\varepsilon_{ph} = \frac{1}{2}\varepsilon_{ph}^+ + \frac{1}{2}\varepsilon_{ph}^- \approx \hbar\omega_L \left(1 + \frac{v}{c}\right)$	0.2
----	---	-----

4b	Write down the average momentum of an emitted photon p_{ph} , after the emission process. $P_{ph} = \frac{1}{2}p_{ph}^+ + \frac{1}{2}p_{ph}^- \approx \frac{\hbar\omega_L}{c} \frac{v}{c} = mv \left(\frac{\hbar q}{mv} \frac{v}{c}\right) \approx 0 \quad \text{second order}$	0.2
----	--	-----

4c	Write down the average energy of the atom ε_{at} , after the emission process. $\varepsilon_{at} = \frac{1}{2}\varepsilon_{at}^+ + \frac{1}{2}\varepsilon_{at}^- \approx \frac{mv^2}{2} \left(1 - \frac{\hbar q}{mv}\right)$	0.2
----	---	-----

4d	Write down the average momentum of the atom p_{at} , after the emission process. $\bar{p}_{at} = \frac{1}{2} p_{at}^+ + \frac{1}{2} p_{at}^- \approx p - \frac{\hbar\omega_L}{c}$	0.2
----	--	-----

5. Energy and momentum transfer.

Assuming a complete one-photon absorption-emission process only, as described above, there is a net average momentum and energy transfer between the laser and the atom.

5a	Write down the average energy change $\Delta\varepsilon$ of the atom after a complete one-photon absorption-emission process. $\Delta\varepsilon = \varepsilon_{at}^{after} - \varepsilon_{at}^{before} \approx -\frac{1}{2}\hbar qv = -\frac{1}{2}\hbar\omega_L \frac{v}{c}$	0.2
----	--	-----

5b	Write down the average momentum change Δp of the atom after a complete one-photon absorption-emission process. $\Delta p = \bar{p}_{at}^{after} - \bar{p}_{at}^{before} \approx -\hbar q = -\frac{\hbar\omega_L}{c}$	0.2
----	---	-----

6. Energy and momentum transfer by a laser beam along the $+x$ direction.

6a	Write down the average energy change $\Delta\varepsilon$ of the atom after a complete one-photon absorption-emission process. $\Delta\varepsilon = \varepsilon_{at}^{after} - \varepsilon_{at}^{before} \approx +\frac{1}{2}\hbar qv = +\frac{1}{2}\hbar\omega'_L \frac{v}{c}$	0.3
----	---	-----

6b	Write down the average momentum change Δp of the atom after a complete one-photon absorption-emission process. $\Delta p = \bar{p}_{at}^{after} - \bar{p}_{at}^{before} \approx +\hbar q = +\frac{\hbar\omega'_L}{c}$	0.3
----	--	-----

PART II: DISSIPATION AND THE FUNDAMENTALS OF OPTICAL MOLASSES

Two counterpropagating laser beams with the *same* but *arbitrary* frequency ω_L are incident on a beam of N atoms that move in the $+x$ direction with (average) velocity v .

7. Force on the atomic beam by the lasers.

On the average, the fraction of atoms found in the excited state is given by,

$$P_{exc} = \frac{N_{exc}}{N} = \frac{\Omega_R^2}{(\omega_0 - \omega_L)^2 + \frac{\Gamma^2}{4} + 2\Omega_R^2}$$

where ω_0 is the resonance frequency of the atoms and Ω_R is the so-called Rabi frequency; Ω_R^2 is proportional to the *intensity* of the laser beam. The lifetime of the excited energy level of the atom is Γ^{-1} .

The force is calculated as the number of absorption-emission cycles, times the momentum exchange in each event, divided by the time of each event. CAREFUL! One must take into account the Doppler shift of each laser, as seen by the atoms:

7a	<p>With the information found so far, find the force that the lasers exert on the atomic beam. You must assume that $mv \gg \hbar q$.</p> $F = N\Delta p^- P_{exc}^- \Gamma + N\Delta p^+ P_{exc}^+ \Gamma$ $= \left(\frac{\Omega_R^2}{\left(\omega_0 - \omega_L + \omega_L \frac{v}{c}\right)^2 + \frac{\Gamma^2}{4} + 2\Omega_R^2} - \frac{\Omega_R^2}{\left(\omega_0 - \omega_L - \omega_L \frac{v}{c}\right)^2 + \frac{\Gamma^2}{4} + 2\Omega_R^2} \right) N\Gamma \hbar q$	1.5
----	---	-----

8. Low velocity limit.

Assume now the velocity to be small enough in order to expand the force to first order in v .

8a	<p>Find an expression for the force found in Question (7a), in this limit.</p> $F \approx - \frac{4N\hbar q^2 \Omega_R^2 \Gamma}{\left(\omega_0 - \omega_L\right)^2 + \frac{\Gamma^2}{4} + 2\Omega_R^2} (\omega_0 - \omega_L) v$	1.5
----	--	-----

8b	<p>Write down the condition to obtain a positive force (speeding up the atom). $\omega_0 < \omega_L$</p>	0.25
----	--	------

8c	<p>Write down the condition to obtain a zero force. $\omega_0 = \omega_L$</p>	0.25
----	--	------

8d	Write down the condition to obtain a negative force (slowing down the atom). $\omega_0 > \omega_L$... this is the famous rule “tune below resonance for cooling down”	0.25
----	---	------

8e	Consider now that the atoms are moving with a velocity $-v$ (in the $-x$ direction). Write down the condition to obtain a slowing down force on the atoms. $\omega_0 > \omega_L$... i.e. independent of the direction motion of the atom.	0.25
----	---	------

9. Optical molasses

In the case of a negative force, one obtains a frictional dissipative force. Assume that initially, $t=0$, the gas of atoms has velocity v_0 .

9a	In the limit of low velocities, find the velocity of the atoms after the laser beams have been on for a time τ . $F = -\beta v \Rightarrow m \frac{dv}{dt} \approx -\beta v \quad \beta \text{ can be read from (8a)}$ $\Rightarrow v = v_0 e^{-\beta t / m}$	1.5
----	--	-----

9b	Assume now that the gas of atoms is in thermal equilibrium at a temperature T_0 . Find the temperature T after the laser beams have been on for a time τ . Recalling that $\frac{1}{2} m v^2 = \frac{1}{2} k T$ in 1 dimension, and using v as the average thermal velocity in the equation of (9a), we can write down $T = T_0 e^{-2\beta t / m}$	0.5
----	---	-----

Answers

Theoretical Problem No. 3

Why are stars so large?

1) *A first, classic estimate of the temperature at the center of the stars.*

1a	<p>We equate the initial kinetic energy of the two protons to the electric potential energy at the distance of closest approach:</p> $2\left(\frac{1}{2}m_p v_{rms}^2\right) = \frac{q^2}{4\pi\epsilon_0 d_c}; \text{ and since}$ $\frac{3}{2}kT_c = \frac{1}{2}m_p v_{rms}^2, \text{ we obtain}$ $T_c = \frac{q^2}{12\pi\epsilon_0 d_c k} = 5.5 \times 10^9 \text{ K}$	1.5
----	---	-----

2) *Finding that the previous temperature estimate is wrong.*

2a	<p>Since we have that</p> $\frac{\Delta P}{\Delta r} = -\frac{GM_r \rho_r}{r^2}, \text{ making the assumptions given above, we obtain that:}$ $P_c = \frac{GM \rho_c}{R}. \text{ Now, the pressure of an ideal gas is}$ $P_c = \frac{2\rho_c kT_c}{m_p}, \text{ where } k \text{ is Boltzmann's constant, } T_c \text{ is the central}$ <p>temperature of the star, and m_p is the proton mass. The factor of 2 in the previous equation appears because we have two particles (one proton and one electron) per proton mass and that both contribute equally to the pressure. Equating the two previous equations, we finally obtain that:</p> $T_c = \frac{GM m_p}{2kR}$	0.5
----	---	-----

2b	<p>From section (2a) we have that:</p> $\frac{M}{R} = \frac{2kT_c}{Gm_p}$	0.5
----	---	-----

2c	From section (2b) we have that, for $T_c = 5.5 \times 10^9$ K: $\frac{M}{R} = \frac{2kT_c}{Gm_p} = 1.4 \times 10^{24} \text{ kg m}^{-1}.$	0.5
----	--	-----

2d	For the Sun we have that: $\frac{M(\text{Sun})}{R(\text{Sun})} = 2.9 \times 10^{21} \text{ kg m}^{-1},$ that is, three orders of magnitude smaller.	0.5
----	--	-----

3) *A quantum mechanical estimate of the temperature at the center of the stars*

3a	We have that $\lambda_p = \frac{h}{m_p v_{rms}},$ and since $\frac{3}{2}kT_c = \frac{1}{2}m_p v_{rms}^2,$ and $T_c = \frac{q^2}{12\pi\epsilon_0 d_c k},$ we obtain: $T_c = \frac{q^4 m_p}{24\pi^2 \epsilon_0^2 k h^2}.$	1.0
----	---	-----

3b	$T_c = \frac{q^4 m_p}{24\pi^2 \epsilon_0^2 k h^2} = 9.7 \times 10^6 \text{ K}.$	0.5
----	---	-----

3c	From section (2b) we have that, for $T_c = 9.7 \times 10^6$ K: $\frac{M}{R} = \frac{2kT_c}{Gm_p} = 2.4 \times 10^{21} \text{ kg m}^{-1};$ while for the Sun we have that: $\frac{M(\text{Sun})}{R(\text{Sun})} = 2.9 \times 10^{21} \text{ kg m}^{-1}.$	0.5
----	---	-----

4) *The mass/radius ratio of the stars.*

4a	Taking into account that	0.5
----	--------------------------	-----

	$\frac{M}{R} = \frac{2kT_c}{Gm_p}, \text{ and that}$ $T_c = \frac{q^4 m_p}{24\pi^2 \epsilon_0^2 k h^2}, \text{ we obtain:}$ $\frac{M}{R} = \frac{q^4}{12\pi^2 \epsilon_0^2 G h^2}.$	
--	---	--

5) *The mass and radius of the smallest star.*

5a	$n_e = \frac{M}{(4/3)\pi R^3 m_p}$	0.5
----	------------------------------------	-----

5b	$d_e = n_e^{-1/3} = \left(\frac{M}{(4/3)\pi R^3 m_p} \right)^{-1/3}$	0.5
----	---	-----

5c	<p>We assume that</p> $d_e \geq \frac{\lambda_e}{2^{1/2}}. \text{ Since}$ $\lambda_e = \frac{h}{m_e v_{rms}(\text{electron})},$ $\frac{3}{2}kT_c = \frac{1}{2}m_e v_{rms}^2(\text{electron}),$ $T_c = \frac{q^4 m_p}{24\pi^2 \epsilon_0^2 k h^2},$ $\frac{M}{R} = \frac{q^4}{12\pi^2 \epsilon_0^2 G h^2}, \text{ and}$ $d_e = \left(\frac{M}{(4/3)\pi R^3 m_p} \right)^{-1/3},$ <p>we get that</p> $R \geq \frac{\epsilon_0^{1/2} h^2}{4^{1/4} q m_e^{3/4} m_p^{5/4} G^{1/2}}$	1.5
----	---	-----

5d	$R \geq \frac{\epsilon_0^{1/2} h^2}{4^{1/4} q m_e^{3/4} m_p^{5/4} G^{1/2}} = 6.9 \times 10^7 \text{ m} = 0.10 R(\text{Sun})$	0.5
----	--	-----

5e	<p>The mass to radius ratio is:</p> $\frac{M}{R} = \frac{q^4}{12\pi^2 \epsilon_0^2 G h^2} = 2.4 \times 10^{21} \text{ kg m}^{-1}, \text{ from where we derive that}$ $M \geq 1.7 \times 10^{29} \text{ kg} = 0.09 M(\text{Sun})$	0.5
----	--	-----

6) *Fusing helium nuclei in older stars.*

6a	<p>For helium we have that</p> $\frac{4q^2}{4\pi \epsilon_0 m_{\text{He}} v_{\text{rms}}^2(\text{He})} = \frac{h}{2^{1/2} m_{\text{He}} v_{\text{rms}}(\text{He})}; \text{ from where we get}$ $v_{\text{rms}}(\text{He}) = \frac{2^{1/2} q^2}{\pi \epsilon_0 h} = 2.0 \times 10^6 \text{ m s}^{-1}.$ <p>We now use:</p> $T(\text{He}) = \frac{v_{\text{rms}}^2(\text{He}) m_{\text{He}}}{3k} = 6.5 \times 10^8 \text{ K.}$ <p>This value is of the order of magnitude of the estimates of stellar models.</p>	0.5
----	--	-----

Answer Form
Experimental Problem No. 1
Diode laser wavelength

Task 1.1 Experimental setup.

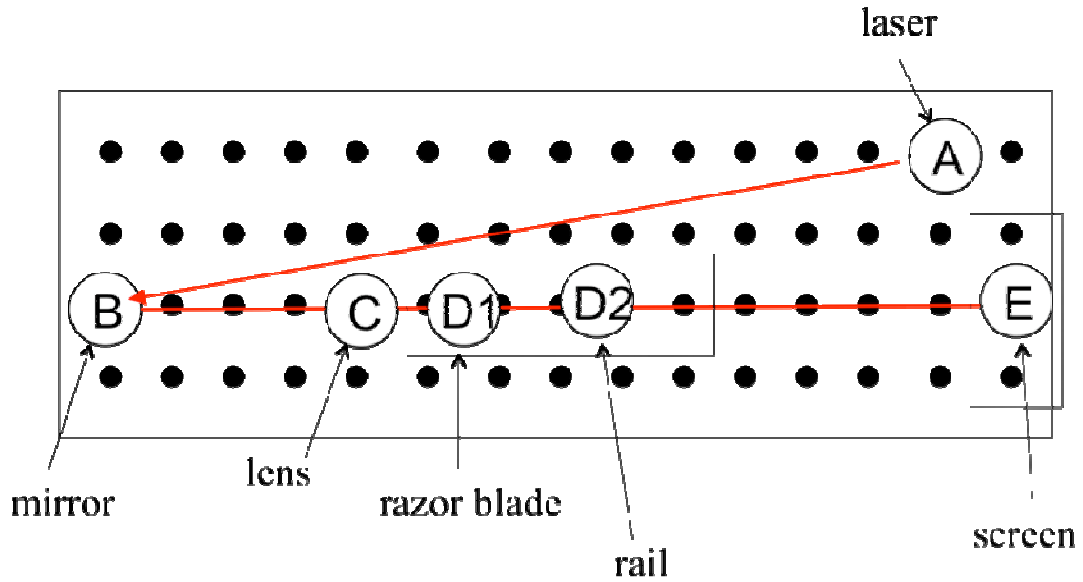

(0.75)

1.1	Sketch the laser path in drawing of Task 1.1 and Write down the height h of the beam as measured from the table $h \pm \Delta h = (5.0 \pm 0.05) \times 10^{-2} \text{ m}$ (0.25)	1.0
-----	--	-----

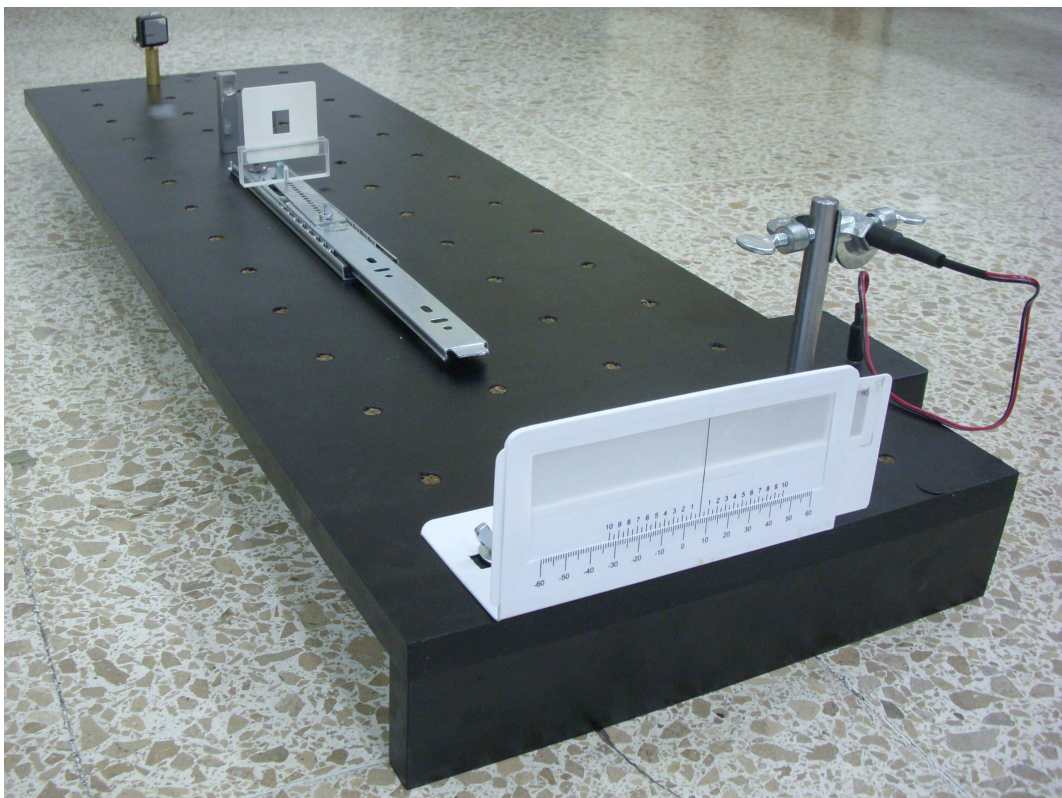
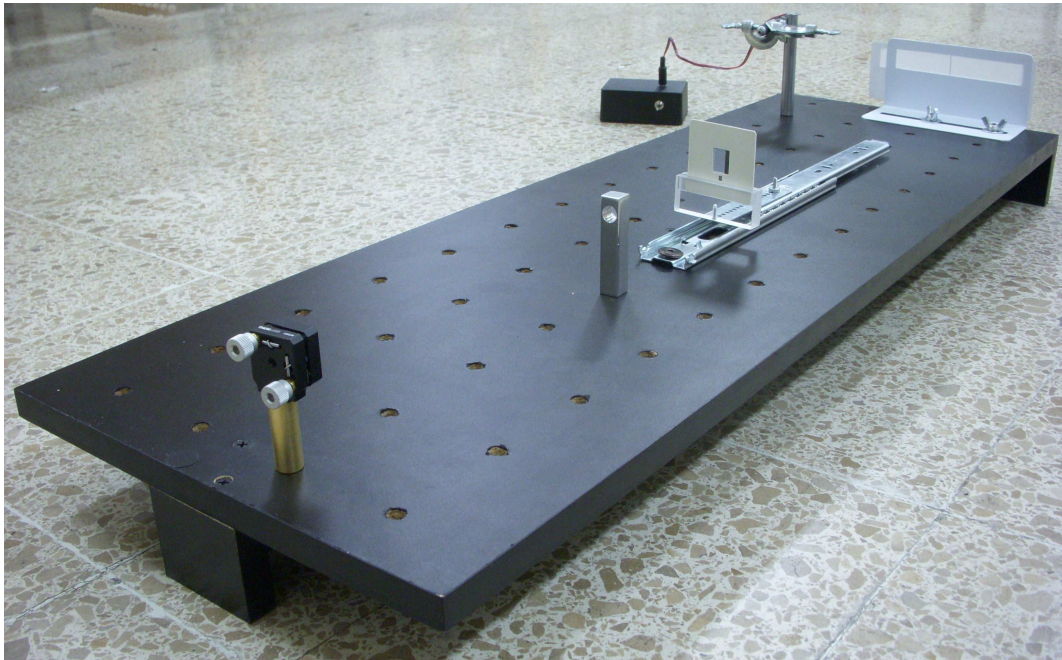

**Experimental setup for measurement of diode laser wavelength
Task 1.2 Expressions for optical path differences.**

1.2	<p>The path differences are</p> <p>Case I: (0.25)</p> $\Delta_I(n) = (BF + FP) - BP = (L_b - L_0) + \sqrt{L_0^2 + L_R^2(n)} - \sqrt{L_b^2 + L_R^2(n)}$ $= (L_b - L_0) + L_0 \sqrt{1 + \frac{L_R^2(n)}{L_0^2}} - L_b \sqrt{1 + \frac{L_R^2(n)}{L_b^2}}$ <p>using $\sqrt{1+x} \approx 1 + \frac{1}{2}x$</p> $\approx (L_b - L_0) + L_0 \left(1 + \frac{1}{2} \frac{L_R^2(n)}{L_0^2}\right) - L_b \left(1 + \frac{1}{2} \frac{L_R^2(n)}{L_b^2}\right)$ $\Rightarrow \Delta_I(n) \approx \frac{1}{2} L_R^2(n) \left(\frac{1}{L_0} - \frac{1}{L_b}\right)$ <p>Case II: (0.25)</p> $\Delta_{II}(n) = (FB + BP) - FP = (L_0 - L_a) + \sqrt{L_a^2 + L_L^2(n)} - \sqrt{L_0^2 + L_L^2(n)}$ $\approx (L_0 - L_a) + L_a \sqrt{1 + \frac{L_L^2(n)}{L_a^2}} - L_0 \sqrt{1 + \frac{L_L^2(n)}{L_0^2}}$ <p>using $\sqrt{1+x} \approx 1 + \frac{1}{2}x$</p> $\approx (L_0 - L_a) + L_a \left(1 + \frac{1}{2} \frac{L_L^2(n)}{L_a^2}\right) - L_0 \left(1 + \frac{1}{2} \frac{L_L^2(n)}{L_0^2}\right)$ $\Rightarrow \Delta_{II}(n) \approx \frac{1}{2} L_L^2(n) \left(\frac{1}{L_a} - \frac{1}{L_0}\right)$	0.5
-----	--	-----

Task 1.3 Measuring the dark fringe positions and locations of the blade. Use additional sheets if necessary.

TABLE I

n	$(l_R(n) \pm 0.1) \times 10^{-3}$ m	$(l_L(n) \pm 0.1) \times 10^{-3}$ m	x_R	x_L
0	-7.5	1.1	0.791	0.935
1	-10.1	3.7	1.275	1.369
2	-12.4	6.4	1.620	1.696
3	-14.0	8.2	1.903	1.968
4	-15.6	10.0	2.151	2.208
5	-17.2	11.4	2.372	2.424
6	-18.4	12.2	2.574	2.622
7	-19.7		2.761	
8	-20.7		2.937	
9	-22.0		3.102	
10	-23.0		3.260	
11	-24.1		3.410	

1.3	<p>Report positions of the blade and their difference with higher precision:</p> $L_b \pm \Delta L_b = (653 \pm 1) \times 10^{-3} \text{ m} \quad (0.25) \text{ LABEL (I) (measuring tape)}$ $L_a \pm \Delta L_a = (628 \pm 1) \times 10^{-3} \text{ m} \quad (0.25) \text{ LABEL (I) (measuring tape)}$ $d = L_b - L_a = (24.6 \pm 0.1) \times 10^{-3} \text{ m} \quad (0.25) \text{ LABEL (H) (caliper)}$	3.25
-----	---	------

W

Student code	Page No.	Total No. of pages

$$x_R = \sqrt{n + \frac{5}{8}}$$

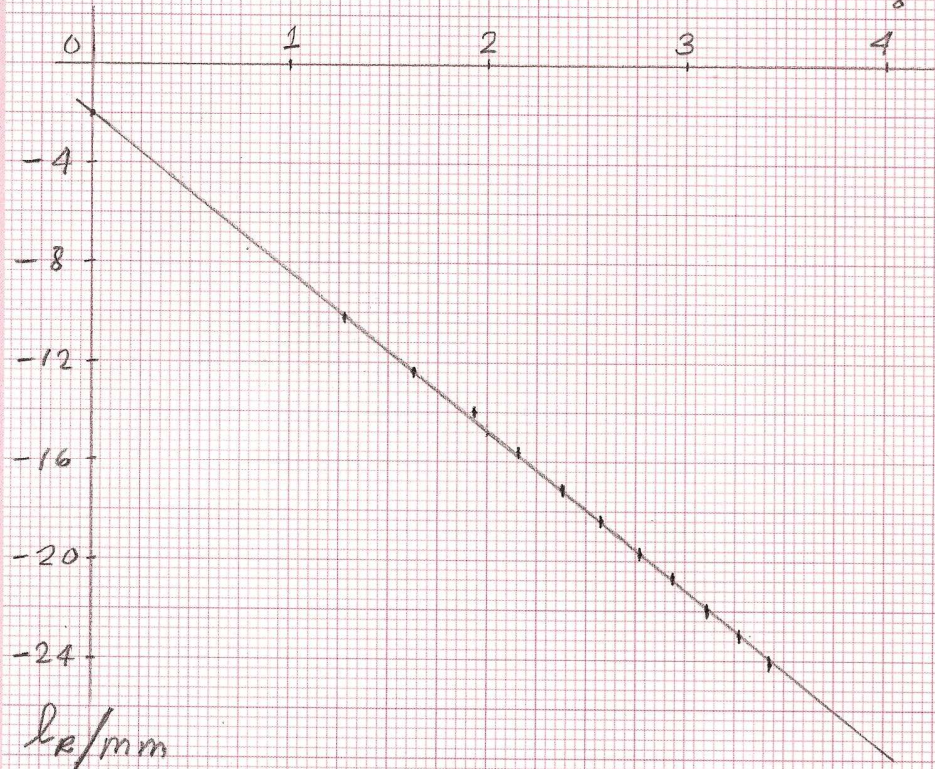

$$\text{fit } l_R = m_R x_R + l_{0R}$$

$$m_R = (-6.39 \pm 0.07) \times 10^{-3} \text{ m}$$

$$l_{0R} = (-2.06 \pm 0.17) \times 10^{-3} \text{ m}$$

W

Student code	Page No.	Total No. of pages

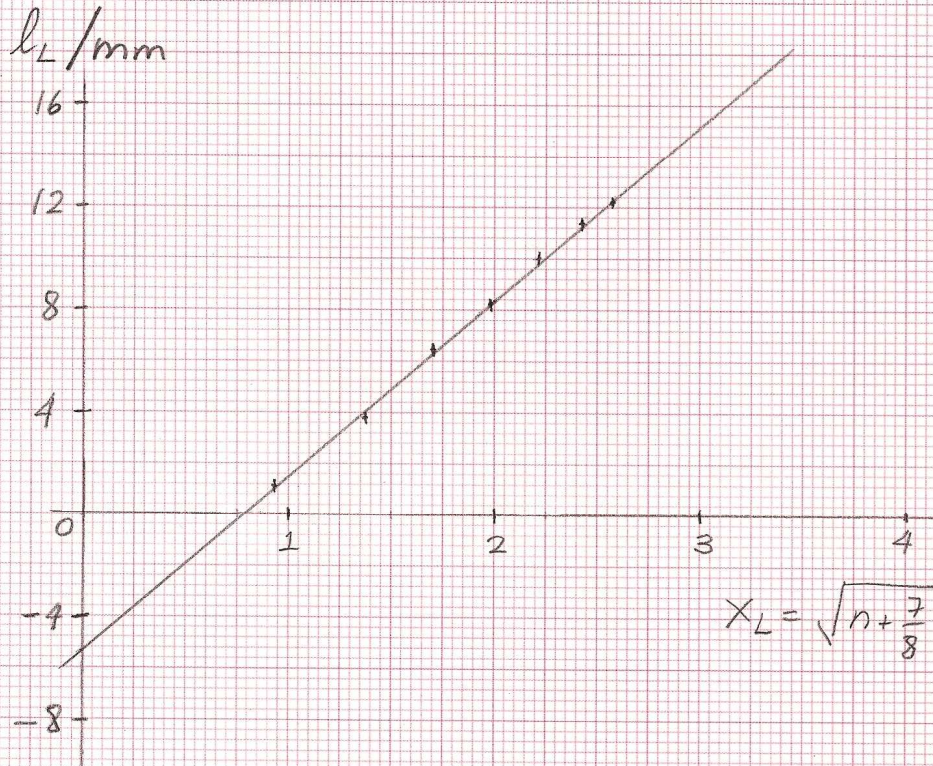

$$\text{fit } l_L = m_L X_L + l_{0L}$$

$$m_L = (6.83 \pm 0.19) \times 10^{-3} \text{ m}$$

$$l_{0L} = (-5.33 \pm 0.36) \times 10^{-3} \text{ m}$$

Task 1.4 Performing a statistical and graphical analysis.

From the condition of dark fringes and Task 1.2, we have

$$\frac{1}{2}L_R^2(n)\left(\frac{1}{L_0} - \frac{1}{L_b}\right) = \left(n + \frac{5}{8}\right)\lambda$$

and

$$\frac{1}{2}L_L^2(n)\left(\frac{1}{L_a} - \frac{1}{L_0}\right) = \left(n + \frac{7}{8}\right)\lambda$$

Using (1.5), $L_R(n) = l_R(n) - l_{0R}$ and $L_L(n) = l_L(n) - l_{0L}$ we can rewrite

$$\frac{1}{2}(l_R(n) - l_{0R})^2\left(\frac{1}{L_0} - \frac{1}{L_b}\right) = \left(n + \frac{5}{8}\right)\lambda$$

$$\Rightarrow l_R(n) = \sqrt{\frac{2L_bL_0}{L_b - L_0}}\lambda\sqrt{n + \frac{5}{8}} + l_{0R}$$

and

$$\frac{1}{2}(l_L(n) - l_{0L})^2\left(\frac{1}{L_a} - \frac{1}{L_0}\right) = \left(n + \frac{7}{8}\right)\lambda$$

$$\Rightarrow l_L(n) = \sqrt{\frac{2L_aL_0}{L_0 - L_a}}\lambda\sqrt{n + \frac{7}{8}} + l_{0L}$$

These can be cast as equations of a straight line, $y = mx + b$.

Case I:

$$y_R = l_R \quad x_R = \sqrt{n + \frac{5}{8}} \quad m_R = \sqrt{\frac{2L_bL_0}{L_b - L_0}}\lambda \quad b_R = l_{0R}$$

Case II:

$$y_L = l_L \quad x_L = \sqrt{n + \frac{7}{8}} \quad m_L = \sqrt{\frac{2L_aL_0}{L_0 - L_a}}\lambda \quad b_L = l_{0L}$$

Perform least squares analysis of above equations. In Table I, we write down the values x_R and x_L .

One finds:

$$m_R \pm \Delta m_R = (-6.39 \pm 0.07) \times 10^{-3} \text{ m}$$

	<p>$m_L \pm \Delta m_L = (6.83 \pm 0.19) \times 10^{-3} \text{ m}$</p> <p>and (values of l_{0R} and l_{0L})</p> <p>$l_{0R} \pm \Delta l_{0R} = b_R \pm \Delta b_R = (-2.06 \pm 0.17) \times 10^{-3} \text{ m}$</p> <p>$l_{0L} \pm \Delta l_{0L} = b_L \pm \Delta b_L = (-5.33 \pm 0.36) \times 10^{-3} \text{ m}$</p> <p>The equations used in the least squares analysis:</p> $m = \frac{N \sum_{n=1}^N x_n y_n - \sum_{n=1}^N x_n \sum_{n'=1}^N y_{n'}}{\Delta}$ $b = \frac{\sum_{n=1}^N x_n^2 \sum_{n'=1}^N y_{n'} - \sum_{n=1}^N x_n \sum_{n'=1}^N x_{n'} y_{n'}}{\Delta}$ <p>where</p> $\Delta = N \sum_{n=1}^N x_n^2 - \left(\sum_{n=1}^N x_n \right)^2$ <p>with N the number of data points. The uncertainty is calculated as</p> $(\Delta m)^2 = N \frac{\sigma^2}{\Delta} \quad , \quad (\Delta b)^2 = \frac{\sigma^2}{\Delta} \sum_{n=1}^N x_n^2 \quad \text{with,}$ $\sigma^2 = \frac{1}{N-2} \sum_{n=1}^N (y_n - b - m x_n)^2$ <p>REFERENCE: P.R. Bevington, <i>Data Reduction and Error Analysis for the Physical Sciences</i>, McGraw-Hill, 1969.</p>	
--	--	--

Task 1.5 Calculating λ .

1.5	<p>From any slope and the value of L_0 one finds,</p> $\lambda = \frac{L_b - L_a}{2L_a L_b} \frac{m_R^2 m_L^2}{m_R^2 + m_L^2}$ <p>Using the suggestion to replace $d = L_b - L_a$, we can write</p>	2.0
-----	---	-----

$$\lambda = \frac{d}{2L_a L_b} \frac{m_R^2 m_L^2}{m_R^2 + m_L^2}$$

$$\lambda \pm \Delta\lambda = (663 \pm 25) \times 10^{-9} \text{ m}$$

The uncertainty may range from 15 to 30 nanometers.

A precise measurement of the wavelength is $\lambda \pm \Delta\lambda = (655 \pm 1) \times 10^{-9} \text{ m}$.

The formula for the uncertainty,

$$\Delta\lambda = \sqrt{\left(\frac{\partial\lambda}{\partial d}\right)^2 \Delta d^2 + \left(\frac{\partial\lambda}{\partial L_a}\right)^2 \Delta L_a^2 + \left(\frac{\partial\lambda}{\partial L_b}\right)^2 \Delta L_b^2 + \left(\frac{\partial\lambda}{\partial m_R}\right)^2 \Delta m_R^2 + \left(\frac{\partial\lambda}{\partial m_L}\right)^2 \Delta m_L^2}$$

one finds,

$$\frac{\partial\lambda}{\partial d} = \frac{\lambda}{d}, \quad \frac{\partial\lambda}{\partial L_b} = \frac{\lambda}{L_b}, \quad \frac{\partial\lambda}{\partial L_a} = \frac{\lambda}{L_a} \quad \text{and} \quad \frac{\partial\lambda}{\partial m_R} = \frac{2m_L^2}{m_R} \frac{\lambda}{m_L^2 + m_R^2}$$

and analogously for the other slope.

One can calculate directly these quantities. However, one may note that the errors due to L_a , L_b and d are negligible. Moreover, $m_R^2 \approx m_L^2$ and $L_a \approx L_b$. This implies,

$$\frac{\partial\lambda}{\partial m_R} \approx \frac{\lambda}{m_R} \approx \frac{\partial\lambda}{\partial m_L}. \quad \text{Thus,}$$

$$\Delta\lambda \approx \sqrt{2} \frac{\lambda}{m_L} \Delta m_L \approx (25 \times 10^{-9}) \text{ m}$$

Answer Form
 Experimental Problem No. 2
 Birefringence of mica

Task 2.1 a) Experimental setup for I_p . (0.5 points)

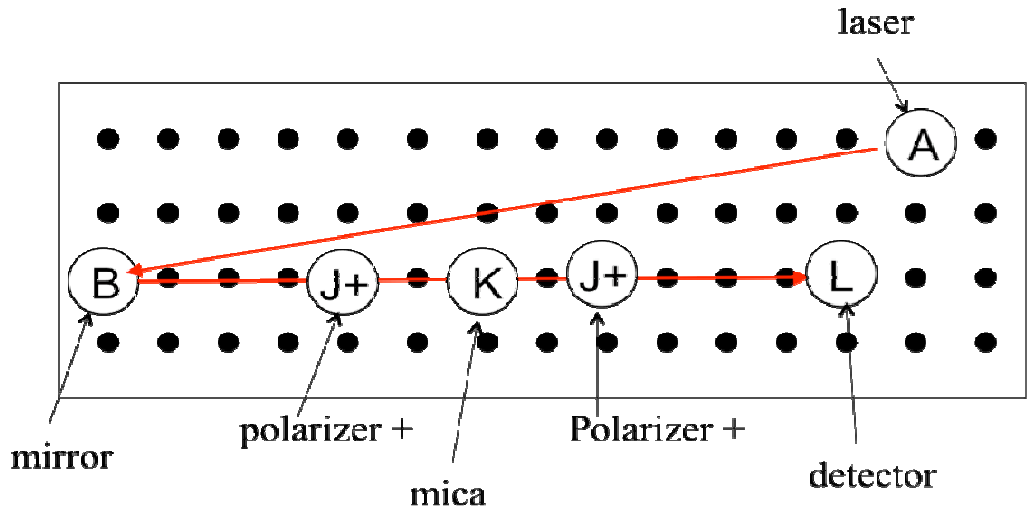

Task 2.1 b) Experimental setup for I_o . (0.5 points)

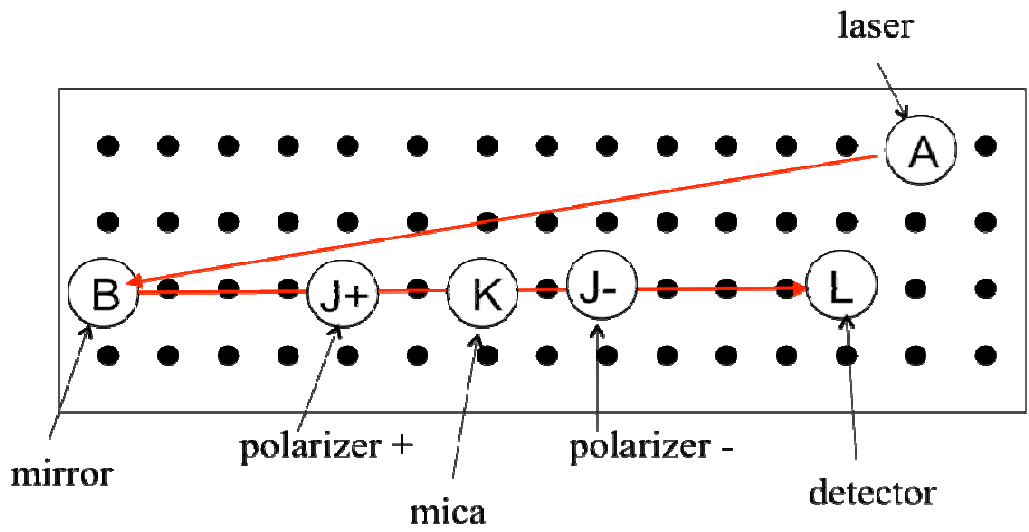

2.1		1.0
-----	--	-----

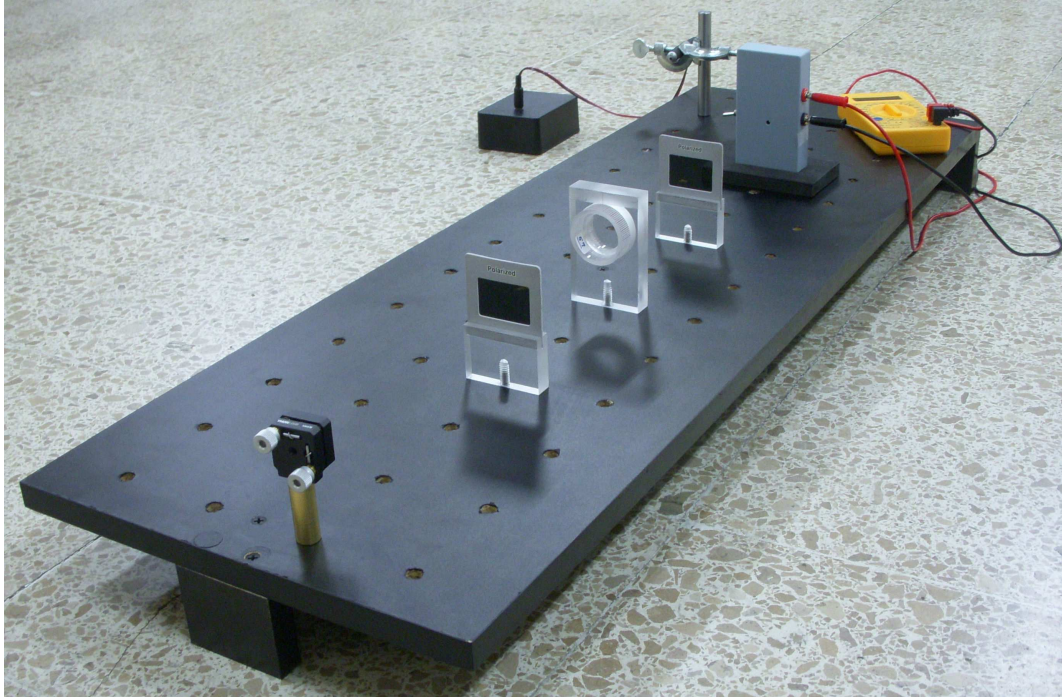

Experimental setup for measurement of mica birefringence

Task 2.2 The scale for angles.

2.2	The angle between two consecutive black lines is $\theta_{\text{int}} = 3.6$ degrees because there are 100 lines.	0.25
-----	--	------

Tasks 2.3 Measuring I_p and I_o .Use additional sheets if necessary.

TABLE I (3 points)

$\bar{\theta}$ (degrees)	$(I_p \pm 1) \times 10^{-3}$ V	$(I_o \pm 1) \times 10^{-3}$ V
-3.6	46.4	1.1
0	48.1	0.2
3.6	47.0	0.6
7.2	46.0	2.0
10.8	42.3	4.9
14.4	38.2	9.0
18.0	33.9	12.5

21.6	27.7	17.9
25.2	23.4	22.0
28.8	17.8	27.0
32.4	12.5	31.7
36.0	8.8	34.8
39.6	5.2	38.0
43.2	3.6	39.4
46.8	3.2	39.6
50.4	4.5	38.7
54.0	6.9	36.6
57.6	10.3	33.6
61.2	14.7	29.4
64.8	20.1	24.7
68.4	25.4	19.7
72.0	30.5	14.7
75.6	36.6	10.2
79.2	40.7	6.1
82.8	44.3	3.2
86.4	46.9	1.0
90.0	47.8	0.2
93.6	47.0	0.4
97.2	45.7	2.0

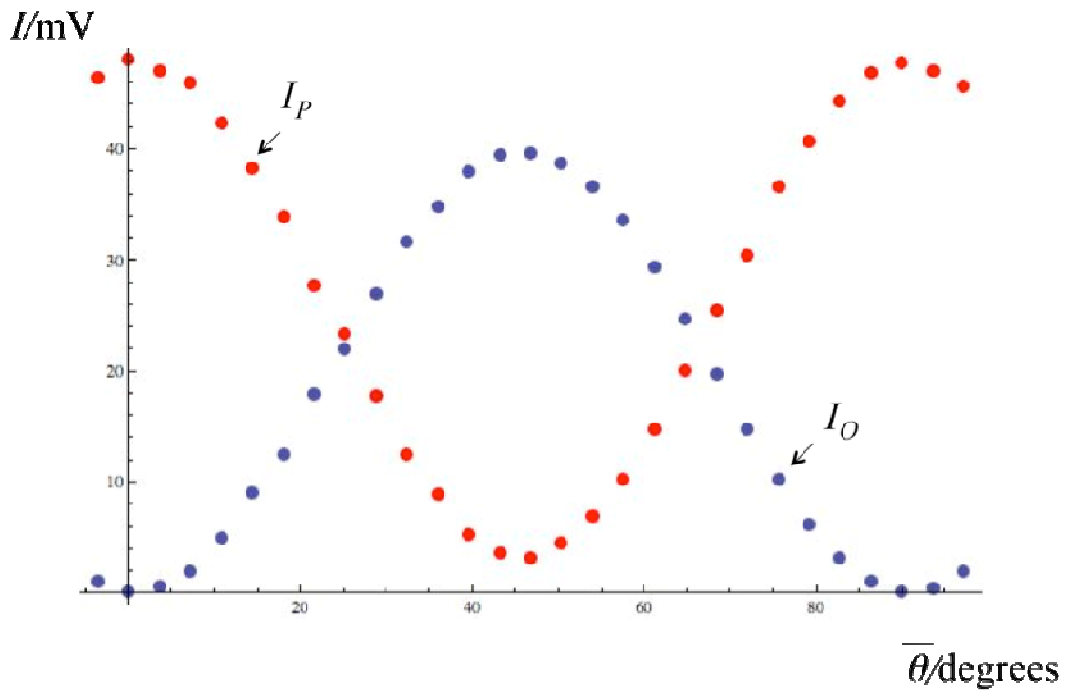

Parallel I_p and perpendicular I_o intensities vs angle $\bar{\theta}$.

GRAPH NOT REQUIRED!

Task 2.4 Finding an appropriate zero for θ .

2.4

a) *Graphical analysis*

1.0

The value for the shift is $\delta\bar{\theta} = -1.0$ degrees.

Add the graph paper with the analysis of this Task.

b) *Numerical analysis*

From Table I choose the first three points of $\bar{\theta}$ and $I_o(\bar{\theta})$:
(intensities in millivolts)

$$(x_1, y_1) = (-3.6, 1.1) \quad (x_2, y_2) = (0, 0.2) \quad (x_3, y_3) = (3.6, 0.6)$$

We want to fit $y = ax^2 + bx + c$. This gives three equations:

$$1.1 = a(3.6)^2 - b(3.6) + c$$

$$0.2 = c$$

$$0.6 = a(3.6)^2 + b(3.6) + c$$

$$\text{second in first} \Rightarrow b = \frac{-0.9 + a(3.6)^2}{3.6}$$

$$\text{in third} \Rightarrow 0.6 = a((3.6)^2 + (3.6)^2) - 0.9 + 0.2$$

$$\Rightarrow a = 0.050 \quad b = -0.069$$

The minimum of the parabola is at:

$$\bar{\theta}_{\min} = -\frac{b}{2a} \approx 0.7 \text{ degrees}$$

Therefore, $\delta\bar{\theta} = -0.7$ degrees.

W

Student code	Page No.	Total No. of pages

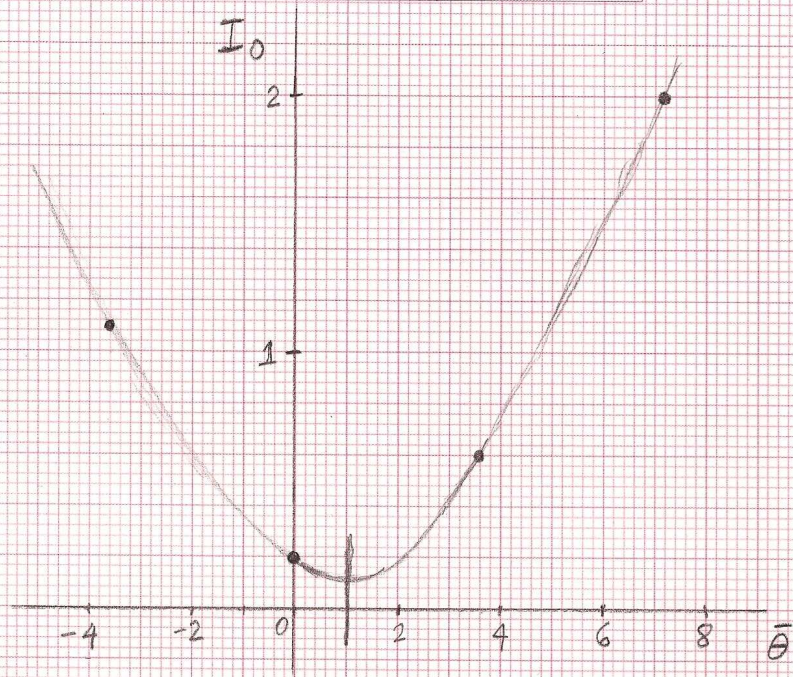

$\bar{\theta}_{\min} \approx 1.0$ degrees

4 points

$\bar{\theta}$	(I_0/mV)
-3.6	1.1
0.0	0.2
3.6	0.6
7.2	2.0

Task 2.5 Choosing the appropriate variables.

2.5	<p>Equation (2.4) for the perpendicular intensity is</p> $\bar{I}_o(\theta) = \frac{1}{2}(1 - \cos\Delta\phi)\sin^2(2\theta)$ <p>This can be cast as a straight line $y = mx + b$, with</p> $y = \bar{I}_o(\theta) \quad , \quad x = \sin^2(2\theta) \quad \text{and} \quad m = \frac{1}{2}(1 - \cos\Delta\phi)$ <p>from which the phase may be obtained.</p> <p>NOTE: This is not the only way to obtain the phase difference. One may, for instance, analyze the 4 maxima of either $\bar{I}_p(\theta)$ or $\bar{I}_o(\theta)$.</p>	0.5
-----	---	-----

Task 2.6 Statistical analysis and the phase difference.

2.6	<p>To perform the statistical analysis, we shall then use</p> $y = \bar{I}_o(\theta) \quad \text{and} \quad x = \sin^2(2\theta) \quad .$	1.0
-----	--	-----

	<p>Since for $\theta: 0 \rightarrow \frac{\pi}{4}$, $x: 0 \rightarrow 1$, we use only 12 pairs of data points to cover this range, as given in Table II.</p> <p>x may be left without uncertainty since it is a setting. The uncertainty in y may be calculated as</p> $\Delta \bar{I}_o = \sqrt{\left(\frac{\partial \bar{I}_o}{\partial I_o}\right)^2 \Delta I_o^2 + \left(\frac{\partial \bar{I}_o}{\partial I_p}\right)^2 \Delta I_p^2}$ <p>and one gets</p> $\Delta \bar{I}_o = \frac{\sqrt{I_o^2 + I_p^2}}{(I_o + I_p)^2} \Delta I_o \approx 0.018, \text{ approximately the same for all values.}$	
--	---	--

TABLE II

$\bar{\theta}$ (degrees)	$x = \sin^2(2\theta)$	$y = \bar{I}_o \pm 0.018$
2.9	0.010	0.013
6.5	0.051	0.042
10.1	0.119	0.104
13.7	0.212	0.191
17.3	0.322	0.269
20.9	0.444	0.392
24.5	0.569	0.484
28.1	0.690	0.603
31.7	0.799	0.717
35.3	0.890	0.798
38.9	0.955	0.880
42.5	0.992	0.916

2.6	<p>We now perform a least square analysis for the variables y vs x in Table II. The slope and y-intercept are:</p> $m \pm \Delta m = 0.913 \pm 0.012$ $b \pm \Delta b = -0.010 \pm 0.008$ <p>The formulas for this analysis are:</p>	1.75
-----	---	------

$$m = \frac{N \sum_{n=1}^N x_n y_n - \sum_{n=1}^N x_n \sum_{n'=1}^N y_{n'}}{\Delta}$$

$$b = \frac{\sum_{n=1}^N x_n^2 \sum_{n'=1}^N y_{n'} - \sum_{n=1}^N x_n \sum_{n'=1}^N x_{n'} y_{n'}}{\Delta}$$

where

$$\Delta = N \sum_{n=1}^N x_n^2 - \left(\sum_{n=1}^N x_n \right)^2$$

with N the number of data points.

The uncertainty is calculated as

$$(\Delta m)^2 = N \frac{\sigma^2}{\Delta} \quad , \quad (\Delta b)^2 = \frac{\sigma^2}{\Delta} \sum_{n=1}^N x_n^2 \quad \text{with,}$$

$$\sigma^2 = \frac{1}{N-2} \sum_{n=1}^N (y_n - b - m x_n)^2$$

with $N = 12$ in this example.

Include the accompanying plot or plots.

Student code

Page No.

Total No. of pages

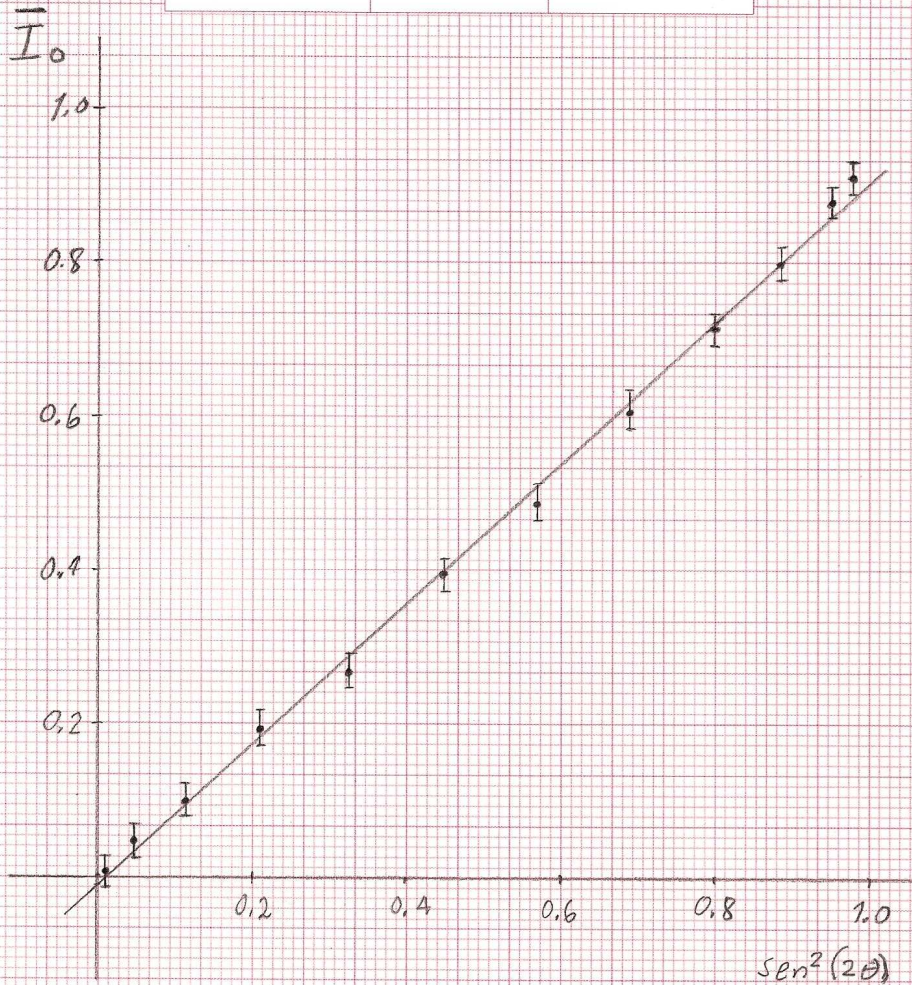

fit $y = mx + b$

$$m = 0.913 \pm 0.012$$

$$b = -0.010 \pm 0.008$$

2.6 Calculate the value of the phase $\Delta\phi$ in radians in the interval $[0, \pi]$.

0.5

From the slope $m = \frac{1}{2}(1 - \cos\Delta\phi)$, one finds

$$\Delta\phi \pm \Delta(\Delta\phi) = 2.54 \pm 0.04$$

Write down the formulas for the calculation of the uncertainty.

We see that,

	$\Delta m = \left \frac{\partial m}{\partial \Delta \phi} \right \Delta(\Delta \phi) = \frac{1}{2} \sin(\Delta \phi) \Delta(\Delta \phi), \text{ therefore, } \Delta(\Delta \phi) = \frac{2\Delta m}{\sin(\Delta \phi)}.$	
--	---	--

Task 2.7 Calculating the birefringence $|n_1 - n_2|$.

2.7	<p>Write down the width of the slab of mica you used,</p> $L \pm \Delta L = (100 \pm 1) \times 10^{-6} \text{ m}$ <p>Write down the wavelength you use,</p> $\lambda \pm \Delta \lambda = (663 \pm 25) \times 10^{-9} \text{ m (from Problem 1)}$ <p>Calculate the birefringence</p> $ n_1 - n_2 \pm \Delta n_1 - n_2 = (3.94 \pm 0.16) \times 10^{-3}$ <p>The birefringence is between 0.003 and 0.005. Nominal value 0.004</p> <p>Write down the formulas you used for the calculation of the uncertainty of the birefringence.</p> <p>Since the width $L > 82$ micrometers, we use</p> $2\pi - \Delta \phi = \frac{2\pi L}{\lambda} n_1 - n_2 $ <p>The error is</p> $\Delta n_1 - n_2 = \sqrt{\left(\frac{\partial n_1 - n_2 }{\partial \lambda} \right)^2 \Delta \lambda^2 + \left(\frac{\partial n_1 - n_2 }{\partial L} \right)^2 \Delta L^2 + \left(\frac{\partial n_1 - n_2 }{\partial \Delta \phi} \right)^2 \Delta(\Delta \phi)^2}$ $\Delta n_1 - n_2 = \sqrt{\left(\frac{ n_1 - n_2 }{\lambda} \right)^2 \Delta \lambda^2 + \left(\frac{ n_1 - n_2 }{L} \right)^2 \Delta L^2 + \left(\frac{\lambda}{2\pi L} \right)^2 \Delta(\Delta \phi)^2}$	1.0
-----	---	-----

Since the data may appear somewhat disperse and/or the errors in the intensities may be large, a graphical analysis may be performed.

In the accompanying plot, it is exemplified a simple graphical analysis: first the main slope is found, then, using the largest deviations one can find two extreme slopes.

The final result is,

$$m = 0.91 \pm 0.08 \quad \text{and} \quad b = -0.01 \pm 0.04$$

The calculation of the birefringence and its uncertainty follows as before. One now finds,

$$|n_1 - n_2| \pm \Delta|n_1 - n_2| = (3.94 \pm 0.45) \times 10^{-3}.$$

A larger (more realistic) error.

W

Student code	Page No.	Total No. of pages

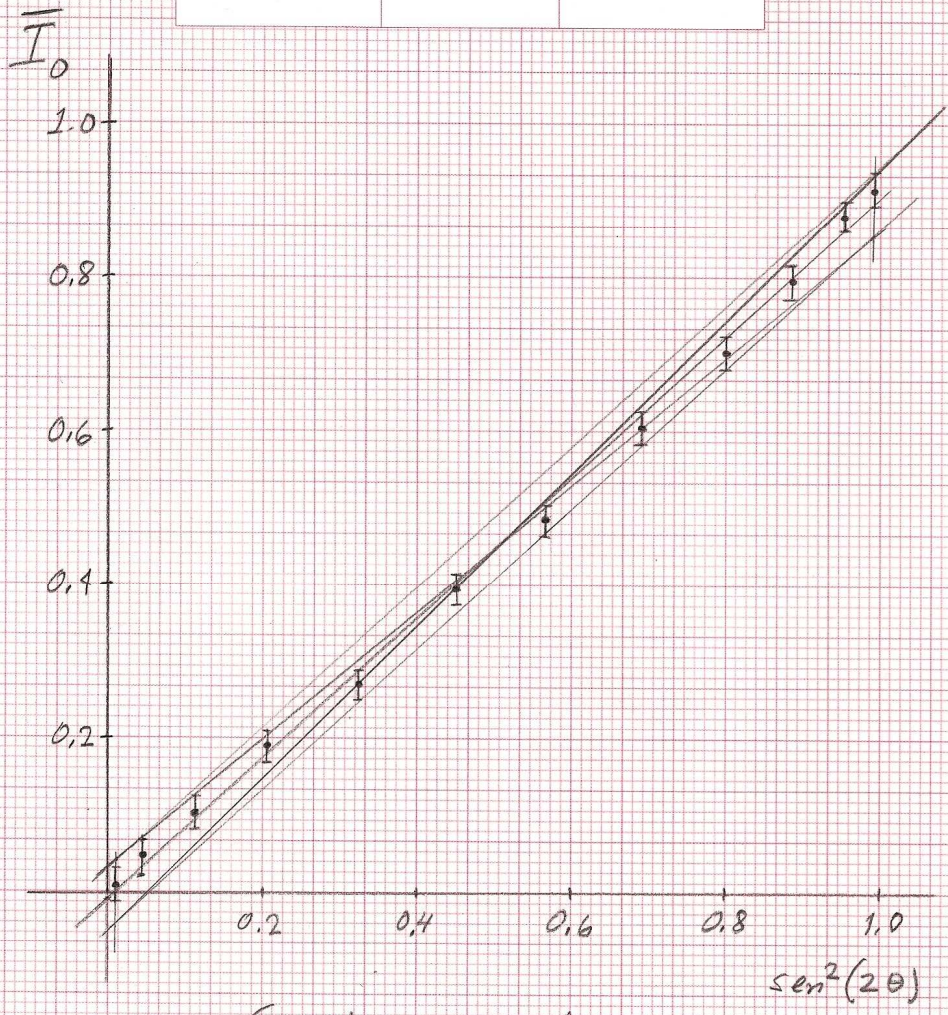

Graphical analysis

$m = 0.91 \pm 0.08$ $b = -0.01 \pm 0.04$

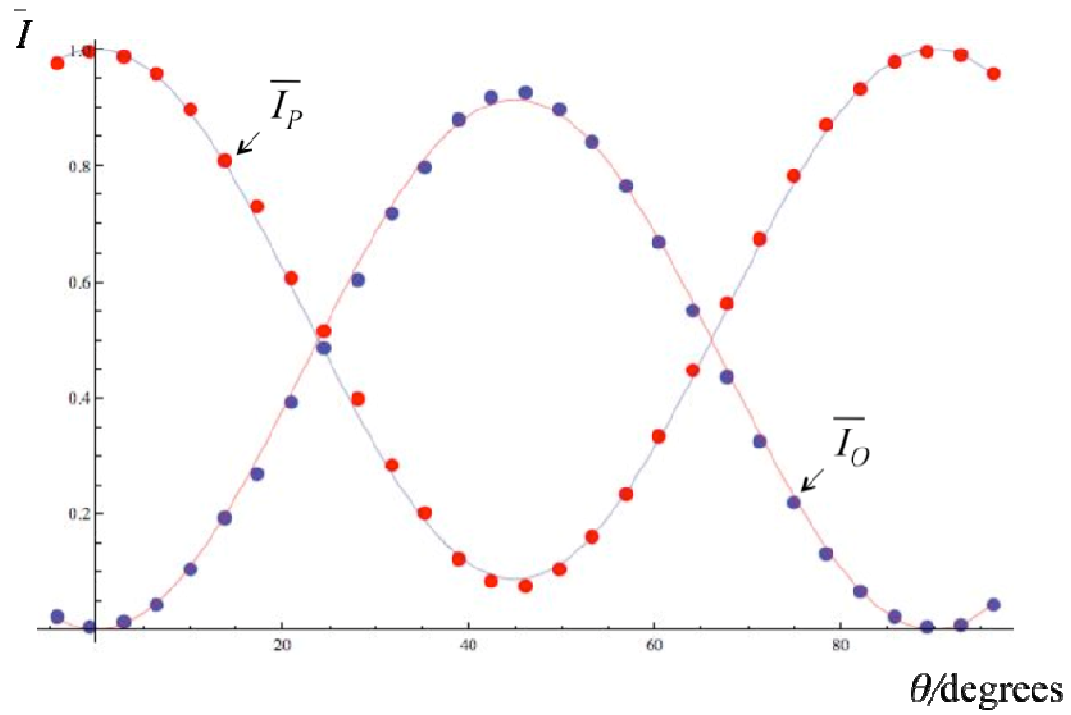

Comparison of experimental data (normalized intensities \bar{I}_p and \bar{I}_o) with fitting (equations (2.3) and (2.4)) using the calculated value of the phase difference $\Delta\phi$.

GRAPH NOT REQUIRED!



The 41st International Physics Olympiad
Croatia
Theoretical Competition
Monday, July 19th 2010

Please read this first:

1. The examination lasts for 5 hours. There are 3 questions each worth **10 points**.
2. Use only the pen issued on your table.
3. Use only the front side of the sheets of paper provided.
4. Use the **Answer Sheets** provided to fill in your answers. Numerical results should be written with as many digits as are appropriate to the given data. *Do not forget to state the units.*
5. Additional **Writing Sheets** are also provided. Write on the working sheets of paper whatever you consider is required for the solution of the questions and that you wish to be marked. However you should use *as little text as possible* and provide only equations, numbers, symbols and diagrams.
6. It is absolutely essential that you enter your **Country Code** and your **Student Code** in the boxes at the top of every sheet of paper used. In addition, on the working sheets of paper used for each question, you should enter the number of the problem (**Problem No.**), the task number (**Task No.**), the progressive number of each sheet (**Page No.**) and the total number of working sheets that you have used and wish to be marked for each question (**Total No. of pages**). If you use some working sheets of paper for notes that you do not wish to be marked, put a large cross through the whole sheet and do not include it in your numbering.
7. When you have finished, arrange all sheets in *proper order*. For each question put
 - answer sheets first;
 - working sheets in order;
 - the sheets you do not wish to be marked;
 - put unused sheets and the printed question at the bottom.

Place the papers for each question in the order of questions and page numbers. Bind them with the paper clip provided and leave everything on your desk. *You are not allowed to take any sheet of paper out of the room.*

1. Image of a charge in a metallic object

Introduction – Method of images

A point charge q is placed in the vicinity of a grounded metallic sphere of radius R [see Fig. 1(a)], and consequently a surface charge distribution is induced on the sphere. To calculate the electric field and potential from the distribution of the surface charge is a formidable task. However, the calculation can be considerably simplified by using the so called method of images. In this method, the electric field and potential produced by the charge distributed on the sphere can be represented as an electric field and potential of a single point charge q' placed inside the sphere (you do not have to prove it). Note: **The electric field of this image charge q' reproduces the electric field and the potential only outside the sphere (including its surface).**

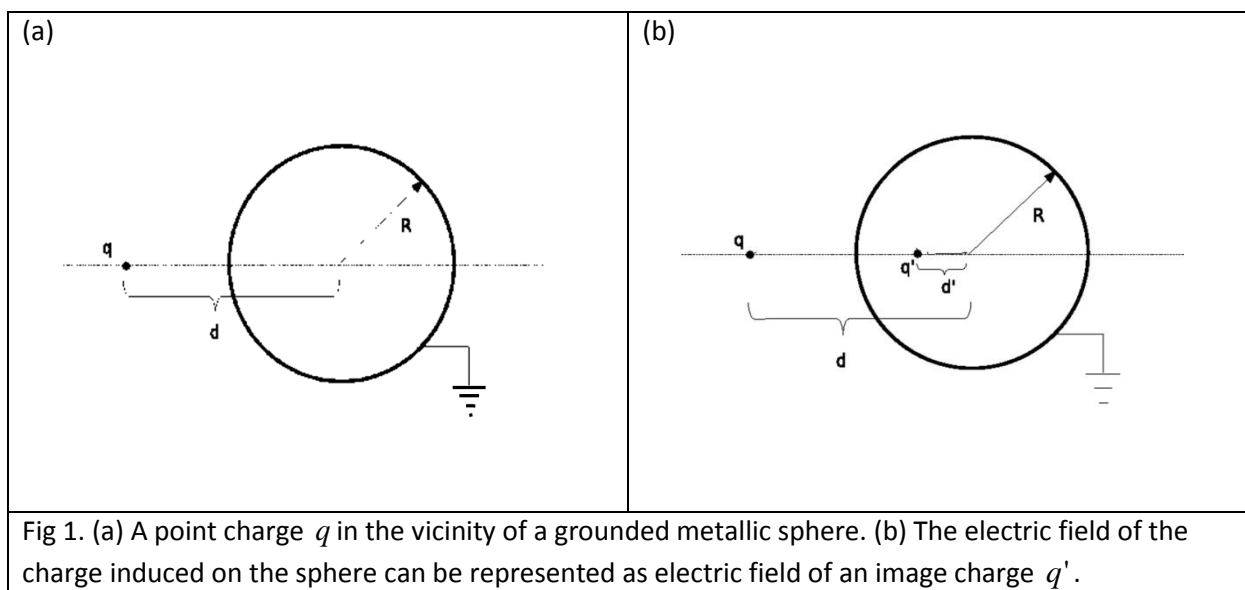

Fig 1. (a) A point charge q in the vicinity of a grounded metallic sphere. (b) The electric field of the charge induced on the sphere can be represented as electric field of an image charge q' .

Task 1 – The image charge

The symmetry of the problem dictates that the charge q' should be placed on the line connecting the point charge q and the center of the sphere [see Fig. 1(b)].

- What is the value of the potential on the sphere? (0.3 points)
- Express q' and the distance d' of the charge q' from the center of the sphere, in terms of q , d , and R . (1.9 points)
- Find the magnitude of force acting on charge q . Is the force repulsive? (0.5 points)

Task 2 – Shielding of an electrostatic field

Consider a point charge q placed at a distance d from the center of a grounded metallic sphere of radius R . We are interested in how the grounded metallic sphere affects the electric field at point A on the opposite side of the sphere (see Fig. 2). Point A is on the line connecting charge q and the center of the sphere; its distance from the point charge q is r .

- Find the vector of the electric field at point A . (0.6 points)

- b) For a very large distance $r \gg d$, find the expression for the electric field by using the approximation $(1+a)^{-2} \approx 1-2a$, where $a \ll 1$. (0.6 points)
- c) In which limit of d does the grounded metallic sphere screen the field of the charge q completely, such that the electric field at point A is exactly zero? (0.3 points)

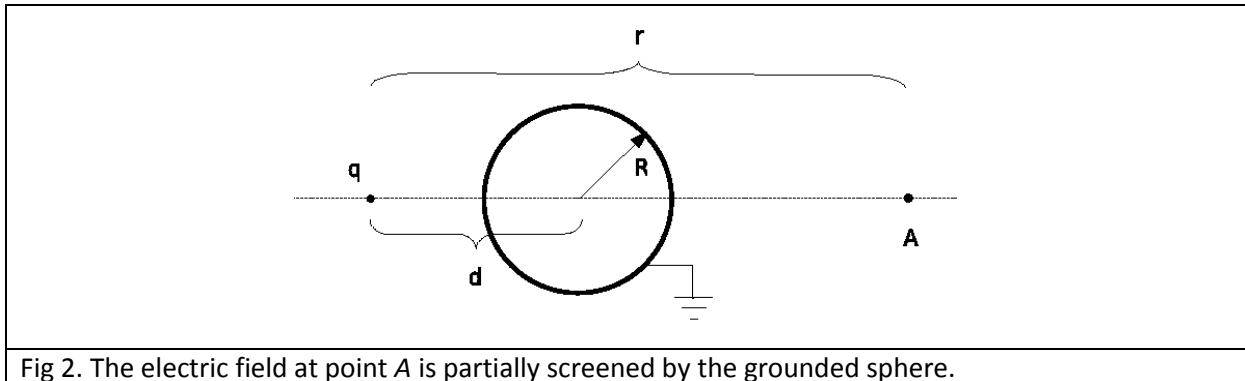

Task 3 – Small oscillations in the electric field of the grounded metallic sphere

A point charge q with mass m is suspended on a thread of length L which is attached to a wall, in the vicinity of the grounded metallic sphere. In your considerations, ignore all electrostatic effects of the wall. The point charge makes a mathematical pendulum (see Fig. 3). The point at which the thread is attached to the wall is at a distance l from the center of the sphere. Assume that the effects of gravity are negligible.

- a) Find the magnitude of the electric force acting on the point charge q for a given angle α and indicate the direction in a clear diagram (0.8 points)
- b) Determine the component of this force acting in the direction perpendicular to the thread in terms of l, L, R, q and α . (0.8 points)
- c) Find the frequency for small oscillations of the pendulum. (1.0 points)

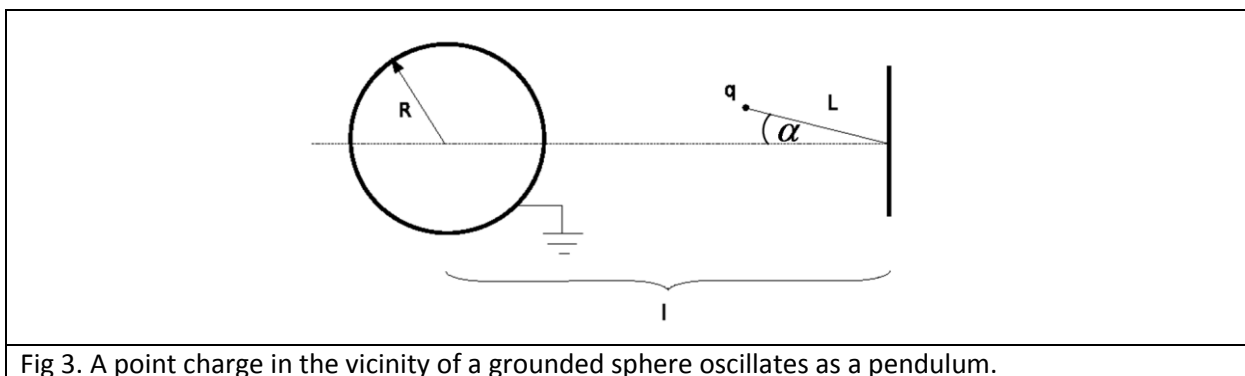

Task 4 – The electrostatic energy of the system

For a distribution of electric charges it is important to know the electrostatic energy of the system. In our problem (see Fig. 1a), there is an electrostatic interaction between the external charge q and the induced charges on the sphere, and there is an electrostatic interaction among the induced charges

on the sphere themselves. In terms of the charge q , radius of the sphere R and the distance d determine the following electrostatic energies:

- a) the electrostatic energy of the interaction between charge q and the induced charges on the sphere; (1.0 points)
- b) the electrostatic energy of the interaction among the induced charges on the sphere; (1.2 points)
- c) the total electrostatic energy of the interaction in the system. (1.0 points)

Hint: There are several ways of solving this problem:

(1) In one of them, you can use the following integral,

$$\int_d^{\infty} \frac{x dx}{(x^2 - R^2)^2} = \frac{1}{2} \frac{1}{d^2 - R^2}.$$

(2) In another one, you can use the fact that for a collection of N charges q_i located at points $\vec{r}_i, i=1, \dots, N$, the electrostatic energy is a sum over all pairs of charges:

$$V = \frac{1}{2} \sum_{i=1}^N \sum_{\substack{j=1 \\ i \neq j}}^N \frac{1}{4\pi\epsilon_0} \frac{q_i q_j}{|\vec{r}_i - \vec{r}_j|}.$$

Image of a Charge – Answer sheets

Country code	Student code

Important: leave the points fields empty for markers!

Task 1		Points
a)		
b)		
c)		
	Yes No	

A Answer sheets - Theoretical problem 1 - Image of a charge

2 / 3

Country code	Student code

Task 2		Points
a)		
b)		
c)		
Task 3		Points
a)		
b)		
c)		

A Answer sheets - Theoretical problem 1 - Image of a charge

3 / 3

Country code	Student code

Task 4		Points
a)		
b)		
c)		
Total:		

2. Chimney physics

Introduction

Gaseous products of burning are released into the atmosphere of temperature T_{Air} through a high chimney of cross-section A and height h (see Fig. 1). The solid matter is burned in the furnace which is at temperature T_{Smoke} . The volume of gases produced per unit time in the furnace is B .

Assume that:

- the velocity of the gases in the furnace is negligibly small
- the density of the gases (smoke) does not differ from that of the air at the same temperature and pressure; while in furnace, the gases can be treated as ideal
- the pressure of the air changes with height in accordance with the hydrostatic law; the change of the density of the air with height is negligible
- the flow of gases fulfills the Bernoulli equation which states that the following quantity is conserved in all points of the flow:

$$\frac{1}{2}\rho v^2(z) + \rho gz + p(z) = const,$$
 where ρ is the density of the gas, $v(z)$ is its velocity, $p(z)$ is pressure, and z is the height
- the change of the density of the gas is negligible throughout the chimney

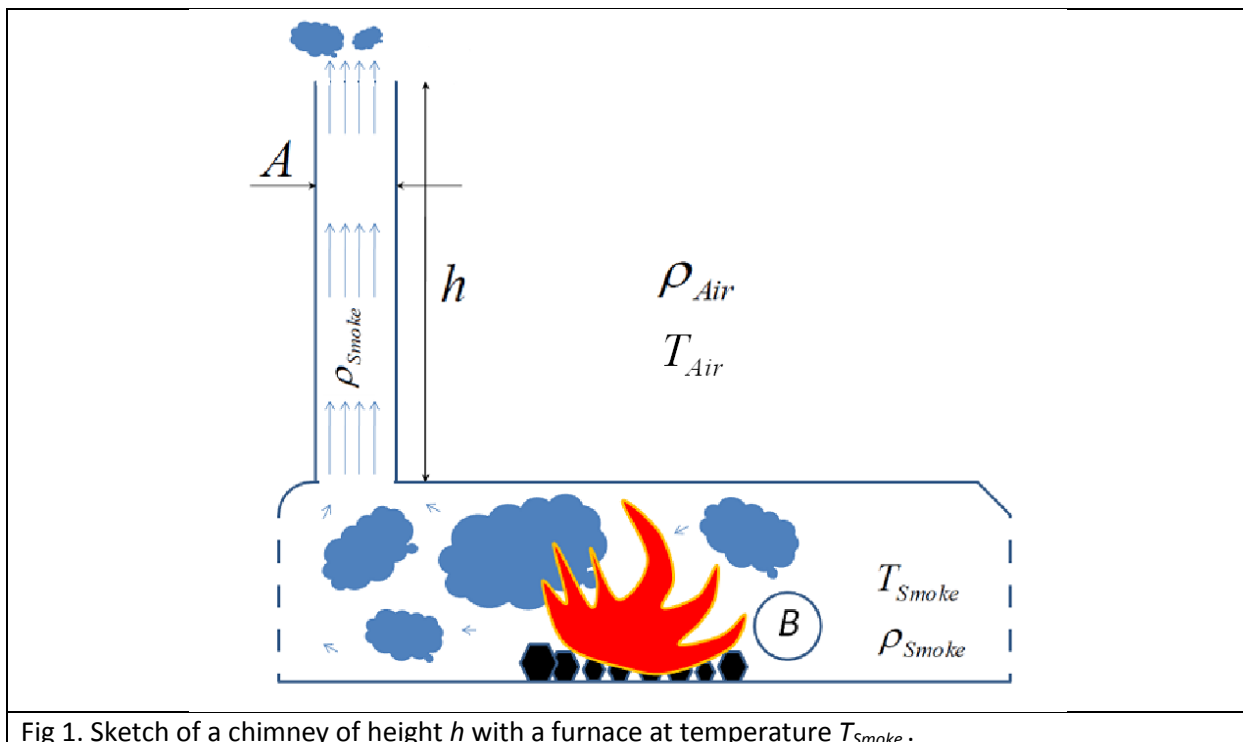

Fig 1. Sketch of a chimney of height h with a furnace at temperature T_{Smoke} .

Task 1

- What is the minimal height of the chimney needed in order that the chimney functions efficiently, so that it can release all of the produced gas into the atmosphere? Express your

result in terms of B , A , T_{Air} , $g=9.81\text{m/s}^2$, $\Delta T=T_{Smoke}-T_{Air}$. **Important: in all subsequent tasks assume that this minimal height is *the* height of the chimney.** (3.5 points)

- b) Assume that two chimneys are built to serve exactly the same purpose. Their cross sections are identical, but are designed to work in different parts of the world: one in cold regions, designed to work at an average atmospheric temperature of $-30\text{ }^\circ\text{C}$ and the other in warm regions, designed to work at an average atmospheric temperature of $30\text{ }^\circ\text{C}$. The temperature of the furnace is $400\text{ }^\circ\text{C}$. It was calculated that the height of the chimney designed to work in cold regions is 100 m. How high is the other chimney? (0.5 points)
- c) How does the velocity of the gases vary along the height of the chimney? Make a sketch/diagram assuming that the chimney cross-section does not change along the height. Indicate the point where the gases enter the chimney. (0.6 points)
- d) How does the pressure of the gases vary along the height of the chimney? (0.5 points)

Solar power plant

The flow of gases in a chimney can be used to construct a particular kind of solar power plant (solar chimney). The idea is illustrated in Fig. 2. The Sun heats the air underneath the collector of area S with an open periphery to allow the undisturbed inflow of air (see Fig. 2). As the heated air rises through the chimney (thin solid arrows), new cold air enters the collector from its surrounding (thick dotted arrows) enabling a continuous flow of air through the power plant. The flow of air through the chimney powers a turbine, resulting in the production of electrical energy. The energy of solar radiation per unit time per unit of horizontal area of the collector is G . Assume that all that energy can be used to heat the air in the collector (the mass heat capacity of the air is c , and one can neglect its dependence on the air temperature). We define the efficiency of the solar chimney as the ratio of the kinetic energy of the gas flow and the solar energy absorbed in heating of the air prior to its entry into the chimney.

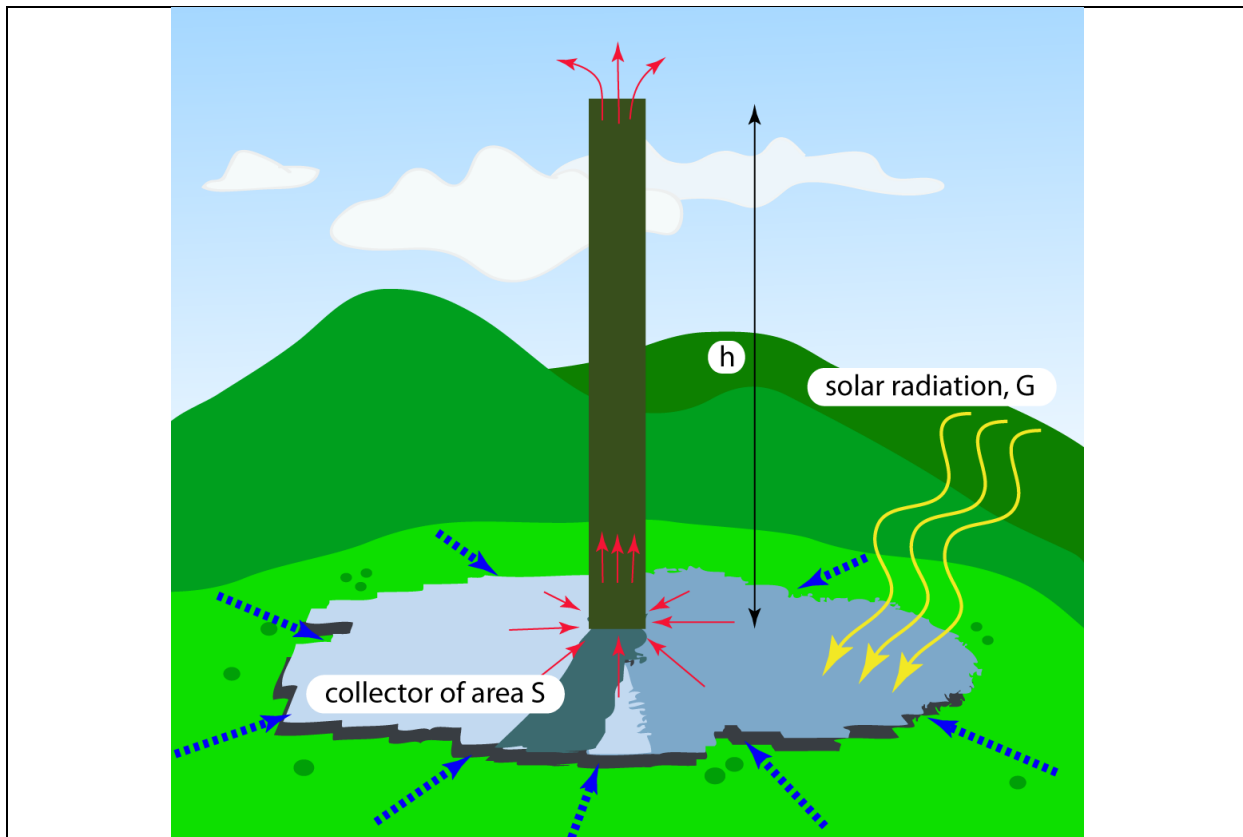

Fig 2. Sketch of a solar power plant.

Task 2

- What is the efficiency of the solar chimney power plant? (2.0 points)
- Make a diagram showing how the efficiency of the chimney changes with its height. (0.4 points)

Manzanares prototype

The prototype chimney built in Manzanares, Spain, had a height of 195 m, and a radius 5 m. The collector is circular with diameter of 244 m. The specific heat of the air under typical operational conditions of the prototype solar chimney is 1012 J/kg K , the density of the hot air is about 0.9 kg/m^3 , and the typical temperature of the atmosphere $T_{\text{Air}} = 295 \text{ K}$. In Manzanares, the solar power per unit of horizontal surface is typically 150 W/m^2 during a sunny day.

Task 3

- What is the efficiency of the prototype power plant? Write down the numerical estimate. (0.3 points)
- How much power could be produced in the prototype power plant? (0.4 points)
- How much energy could the power plant produce during a typical sunny day? (0.3 points)

Task 4

- a) How large is the rise in the air temperature as it enters the chimney (warm air) from the surrounding (cold air)? Write the general formula and evaluate it for the prototype chimney. *(1.0 points)*
- b) What is the mass flow rate of air through the system? *(0.5 points)*

Chimney physics – Answer sheets

Country code	Student code

Important: leave the points fields empty for markers!

Task 1	Points
a)	
b)	
c)	
d)	

Country code	Student code

Task 2		Points
a)		
b)		
Task 3		Points
a)		
b)		
c)		

A Answer sheets - Theoretical problem 2 - Chimney physics

3 / 3

Country code	Student code

Task 4		Points
a)		
b)		
Total:		

3. Simple model of an atomic nucleus

Introduction

Although atomic nuclei are quantum objects, a number of phenomenological laws for their basic properties (like radius or binding energy) can be deduced from simple assumptions: (i) nuclei are built from nucleons (i.e. protons and neutrons); (ii) strong nuclear interaction holding these nucleons together has a very short range (it acts only between neighboring nucleons); (iii) the number of protons (Z) in a given nucleus is approximately equal to the number of neutrons (N), i.e. $Z \approx N \approx A/2$, where A is the total number of nucleons ($A \gg 1$). **Important: Use these assumptions in Tasks 1-4 below.**

Task 1 - Atomic nucleus as closely packed system of nucleons

In a simple model, an atomic nucleus can be thought of as a ball consisting of closely packed nucleons [see Fig. 1(a)], where the nucleons are hard balls of radius $r_N = 0.85$ fm ($1 \text{ fm} = 10^{-15} \text{ m}$). The nuclear force is present only for two nucleons in contact. The volume of the nucleus V is larger than the volume of all nucleons AV_N , where $V_N = \frac{4}{3}r_N^3\pi$. The ratio $f = AV_N/V$ is called the packing factor and gives the percentage of space filled by the nuclear matter.

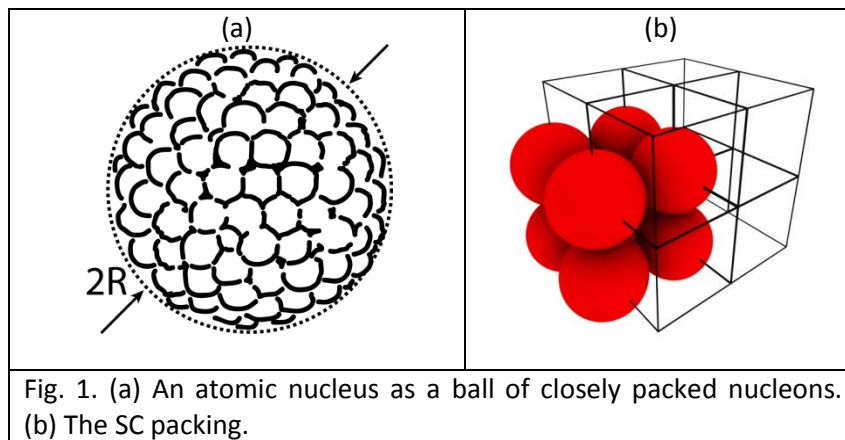

Fig. 1. (a) An atomic nucleus as a ball of closely packed nucleons. (b) The SC packing.

- a) Calculate what would be the packing factor f if nucleons were arranged in a “simple cubic” (SC) crystal system, where each nucleon is centered on a lattice point of an infinite cubic lattice [see Fig. 1(b)]. (0.3 points)

Important: In all subsequent tasks, assume that the actual packing factor for nuclei is equal to the one from Task 1a. If you are not able to calculate it, in subsequent tasks use $f = 1/2$.

- b) Estimate the average mass density ρ_m , charge density ρ_c , and the radius R for a nucleus having A nucleons. The average mass of a nucleon is $1.67 \cdot 10^{-27}$ kg. (1.0 points)

Task 2 - Binding energy of atomic nuclei - volume and surface terms

Binding energy of a nucleus is the energy required to disassemble it into separate nucleons and it essentially comes from the attractive nuclear force of each nucleon with its neighbors. If a given nucleon is not on the surface of the nucleus, it contributes to the total binding energy with $a_V = 15.8$ MeV ($1 \text{ MeV} = 1.602 \cdot 10^{-13} \text{ J}$). The contribution of one surface nucleon to the binding energy is approximately $a_V/2$. Express the binding energy E_b of a nucleus with A nucleons in terms of A , a_V , and f , and by including the surface correction. (1.9 points)

Task 3 - Electrostatic (Coulomb) effects on the binding energy

The electrostatic energy of a homogeneously charged ball (with radius R and total charge Q_0)

$$\text{is } U_c = \frac{3Q_0^2}{20\pi\epsilon_0 R}, \text{ where } \epsilon_0 = 8.85 \cdot 10^{-12} \text{ C}^2 \text{N}^{-1} \text{m}^{-2}.$$

- Apply this formula to get the electrostatic energy of a nucleus. In a nucleus, each proton is not acting upon itself (by Coulomb force), but only upon the rest of the protons. One can take this into account by replacing $Z^2 \rightarrow Z(Z-1)$ in the obtained formula. Use this correction in subsequent tasks. (0.4 points)
- Write down the complete formula for binding energy, including the main (volume) term, the surface correction term and the obtained electrostatic correction. (0.3 points)

Task 4 - Fission of heavy nuclei

Fission is a nuclear process in which a nucleus splits into smaller parts (lighter nuclei). Suppose that a nucleus with A nucleons splits into only two equal parts as depicted in Fig. 2.

- Calculate the total kinetic energy of the fission products E_{kin} when the centers of two lighter nuclei are separated by the distance $d \geq 2R(A/2)$, where $R(A/2)$ is their radius. The large nucleus was initially at rest. (1.3 points)
- Assume that $d = 2R(A/2)$ and evaluate the expression for E_{kin} obtained in part a) for $A = 100, 150, 200$ and 250 (express the results in units of MeV). Estimate the values of A for which fission is possible in the model described above? (1.0 points)

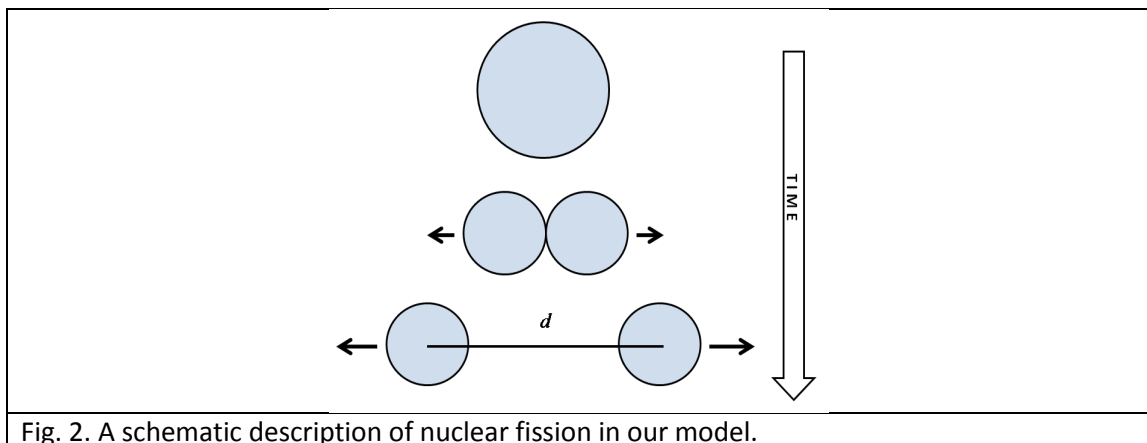

Fig. 2. A schematic description of nuclear fission in our model.

Task 5 – Transfer reactions

- a) In modern physics, the energetics of nuclei and their reactions is described in terms of masses. For example, if a nucleus (with zero velocity) is in an excited state with energy E_{exc} above the ground state, its mass is $m = m_0 + E_{exc} / c^2$, where m_0 is its mass in the ground state at rest. The nuclear reaction $^{16}\text{O} + ^{54}\text{Fe} \rightarrow ^{12}\text{C} + ^{58}\text{Ni}$ is an example of the so-called “transfer reactions”, in which a part of one nucleus (“cluster”) is transferred to the other (see Fig. 3). In our example the transferred part is a ^4He -cluster (α -particle). The transfer reactions occur with maximum probability if the velocity of the projectile-like reaction product (in our case: ^{12}C) is equal both in magnitude and direction to the velocity of projectile (in our case: ^{16}O). The target ^{54}Fe is initially at rest. In the reaction, ^{58}Ni is excited into one of its higher-lying states. Find the excitation energy of that state (and express it units of MeV) if the kinetic energy of the projectile ^{16}O is 50 MeV. The speed of light is $c = 3 \cdot 10^8$ m/s. (2.2 points)

1.	$M(^{16}\text{O})$	15.99491 a.m.u.
2.	$M(^{54}\text{Fe})$	53.93962 a.m.u.
3.	$M(^{12}\text{C})$	12.00000 a.m.u.
4.	$M(^{58}\text{Ni})$	57.93535 a.m.u.

Table 1. The rest masses of the reactants in their ground states. 1 a.m.u. = $1.6605 \cdot 10^{-27}$ kg.

- b) The ^{58}Ni nucleus produced in the excited state discussed in the part a), deexcites into its ground state by emitting a gamma-photon in the direction of its motion. Consider this decay in the frame of reference in which ^{58}Ni is at rest to find the recoil energy of ^{58}Ni (i.e. kinetic energy which ^{58}Ni acquires after the emission of the photon). What is the photon energy in that system? What is the photon energy in the lab system of reference (i.e. what would be the energy of the photon measured in the detector which is positioned in the direction in which the ^{58}Ni nucleus moves)? (1.6 points)

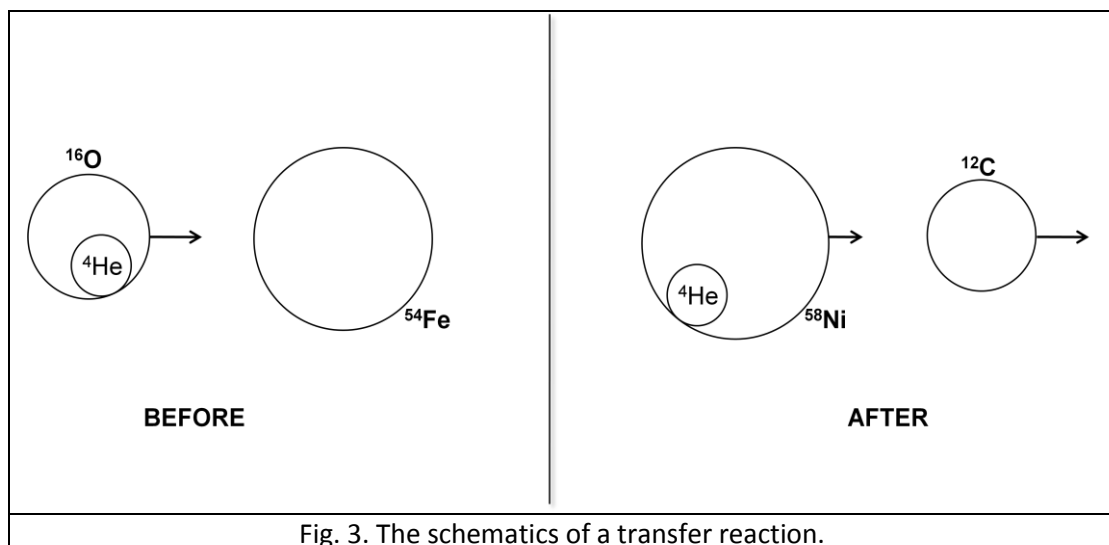

Fig. 3. The schematics of a transfer reaction.

Simple model of atomic nucleus – Answer sheets

Country code	Student code

Important: leave the Points fields empty for markers!

Task 1		Points
a)		
b)	$\rho_m =$	
	$\rho_c =$	
	$R =$	
Task 2		Points

A Answer sheets - Theoretical problem 3 - Nuclear model

2 / 3

Country code	Student code

Task 3		Points
a)		
b)		
Task 4		Points
a)		
b)	$E_{kin}(A=100)=$ $E_{kin}(A=150)=$ $E_{kin}(A=200)=$ $E_{kin}(A=250)=$ necessary condition for fission:	

A Answer sheets - Theoretical problem 3 - Nuclear model

3 / 3

Country code	Student code

Task 5		Points
a)		
b)	$E_\gamma =$	
	$E_{\text{recoil}} =$	
	$E_{\text{detector}} =$	
Total:		



The 41st International Physics Olympiad
Croatia
Experimental Competition
Wednesday, July 21st, 2010

Please read this first:

1. The time given is 5 hours.
2. There are two experimental problems. Each experiment is awarded 10 points.
3. Use only the provided setup, pencil, and sheets.
4. Write your solutions in the **Answer sheets**. **Working sheets** can be used if necessary. *All will be considered for marks.*
5. When using working sheets:
 - Use only the front side of the paper. Start each part on a fresh sheet of paper.
 - On every paper, write:
 - 1) the **Task No.** for the task attempted
 - 2) the **Page No.** - the progressive number of each sheet for that part
 - 3) the **Total No. of Pages** used for that part
 - 4) your **Country Code** and your **Student Code**
 - Write concisely – Limit the use of text to minimum. Use equations, numbers, symbols, figures and graphs as far as possible.
 - Cross out pages that you do not wish to be marked. Do not include them in your numbering.
6. For each task, use the **Answer Sheet** to fill in your *final answer* in the appropriate box. Give the appropriate number of significant figures. Remember to state the units.
7. When you have finished, arrange all sheets in this order *for each part*:
 - the **Answer Sheet**
 - writing sheets that you wish to be marked
 - writing sheets that you do not wish to be markedPlace all unused sheets, graph papers and the question paper at the bottom.
8. Clip *all sheets* together and leave them on your desk.
9. You are not allowed to take *any* sheet of paper or *any* material used in the experiment out of the examination hall.



Separate instructions for using the scale



The scale is turned **ON-OFF** by the **right button**.

The **middle button** (Z/T) sets the digits to zero, that is, this is the **TARA** function.

The **left button** can be used to change **units**.

Instruction: Put units to grams in case it is in other units!

Separate instructions for using the press

The press is used in both problems. The upper part of the press is turned up-side down in the second experiment as compared to the first. **Its position is illustrated in the tasks themselves.** The stone is to be placed on the upper part of the press. Its weight helps the upper part of the press to slide down when you turn the wing-nut (if you find necessary, you can gently press the upper part by your hand (close to the vertical bar) while you turn the wing nut to ensure smooth sliding of the press). **For performing measurements, you should use the fact that the upper part of the press moves 2 mm when the wing nut is rotated 360 degrees.**



SAFETY WARNING

You should be careful when playing with the wooden stick, the rod magnet and the hollow cylinder.

Be careful not to stick the wooden stick in your eyes!!!

Do not look with your eyes into the hollow cylinder when playing with the rod magnet inside the cylinder. It can be ejected from the cylinder and injure your eyes.

Experimental problem 1

There are two experimental problems. The setup on your table is used for both problems. You have 5 hours to complete the entire task (1&2).

Experimental problem 1: Elasticity of sheets

Introduction

Springs are objects made from elastic materials which can be used to store mechanical energy. The most famous helical springs are well described in terms of Hooke's law, which states that the force with which the spring pushes back is linearly proportional to the distance from its equilibrium length: $F = -k\Delta x$, where k is the spring constant, Δx is the displacement from equilibrium, and F is the force [see Fig. 1(a)]. However, elastic springs can have quite different shapes from the usual helical springs, and for larger deformations Hooke's law does not generally apply. In this problem we measure the properties of a spring made from a sheet of elastic material, which is schematically illustrated in Fig. 1(b).

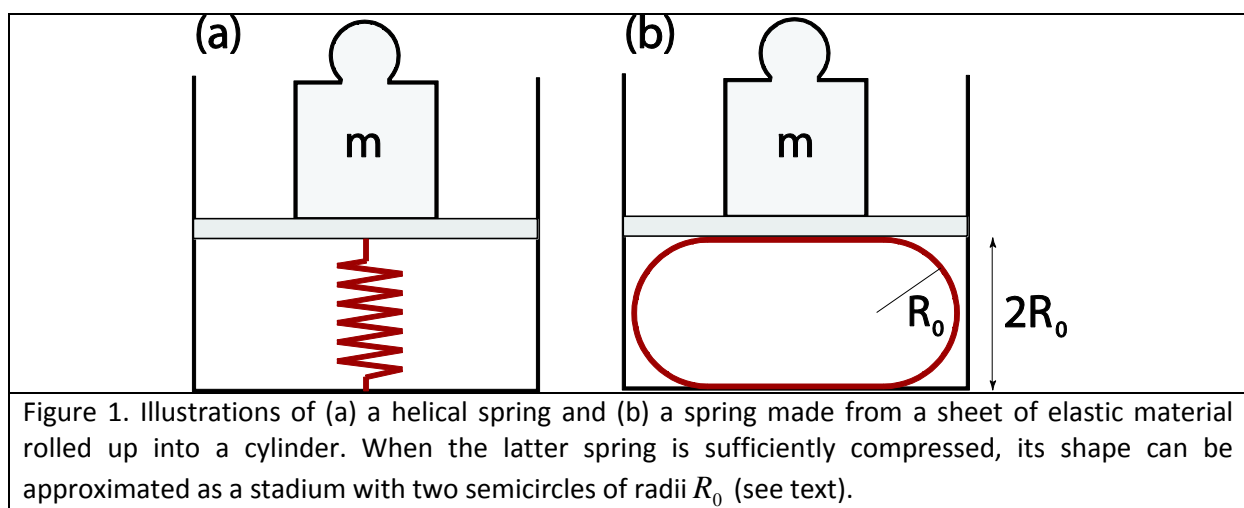

Transparent foil rolled into a cylindrical spring

Suppose that we take a sheet of elastic material (e.g. a transparent foil) and bend it. The more we bend it, the more elastic energy is stored in the sheet. The elastic energy depends on the curvature of the sheet. Parts of the sheet with larger curvature store more energy (flat parts of the sheet do not store energy because their curvature is zero). The springs used in this experiment are made from rectangular transparent foils rolled into cylinders (see Fig. 2). The elastic energy stored in a cylinder is

$E_{el} = \frac{\kappa}{2} \frac{1}{R_c^2} A,$	(1)
--	-----

where A denotes the area of the cylinder's side (excluding its bases), R_c denotes its radius, and the parameter κ , referred to as the bending rigidity, is determined by the elastic properties of the material and the thickness of the sheet. Here we neglect the stretching of the sheets.

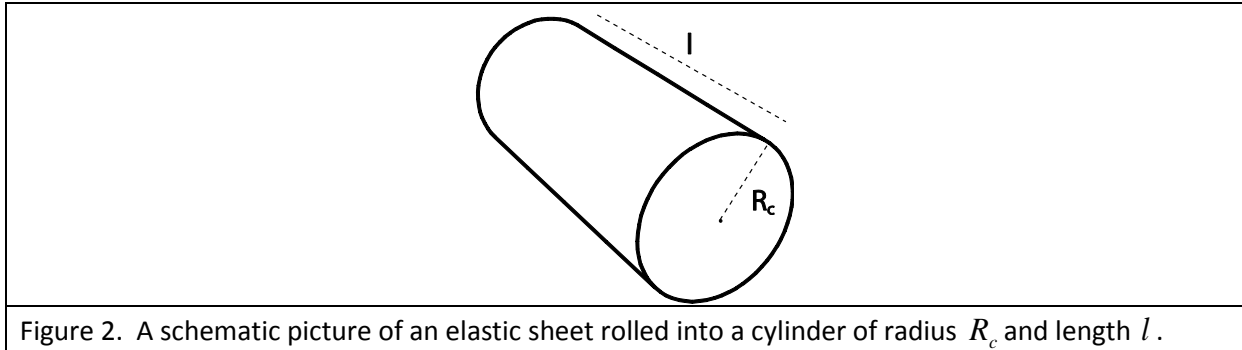

Figure 2. A schematic picture of an elastic sheet rolled into a cylinder of radius R_c and length l .

Suppose that such a cylinder is compressed as in Fig. 1(b). For a given force applied by the press (F), the displacement from equilibrium depends on the elasticity of the transparent foil. For some interval of compression forces, the shape of the compressed transparency foil can be approximated with the shape of a stadium, which has a cross section with two straight lines and two semicircles, both of radius R_0 . It can be shown that the energy of the compressed system is minimal when

$R_0^2 = \frac{l\kappa\pi}{2F}$.	(2)
-----------------------------------	-----

The force is measured by the scale calibrated to measure mass m , so $F = mg$, $g = 9.81 \text{ m/s}^2$.

Experimental setup (1st problem)

The following items (to be used for the 1st problem) are on your desk:

1. Press (together with a stone block); see separate instructions if needed
2. Scale (measures mass up to 5000 g, it has TARA function, see separate instructions if needed)
3. Transparency foils (all foils are 21 cm x 29.7 cm, the blue foil is 200 μm thick, and the colorless foil is 150 μm thick); please, do ask for the extra foils if you need them.
4. Adhesive (scotch) tape
5. Scissors
6. Ruler with a scale
7. A rectangular wooden plate (the plate is to be placed on a scale, and the foil sits on the plate)

The setup is to be used as in Fig. 3. The upper plate of the press can be moved downward and upward using a wing nut, and the force (mass) applied by the press is measured with the scale.

Important: The wing nut moves 2 mm when rotated 360 degrees. (Small aluminum rod is not used in Experiment 1.)

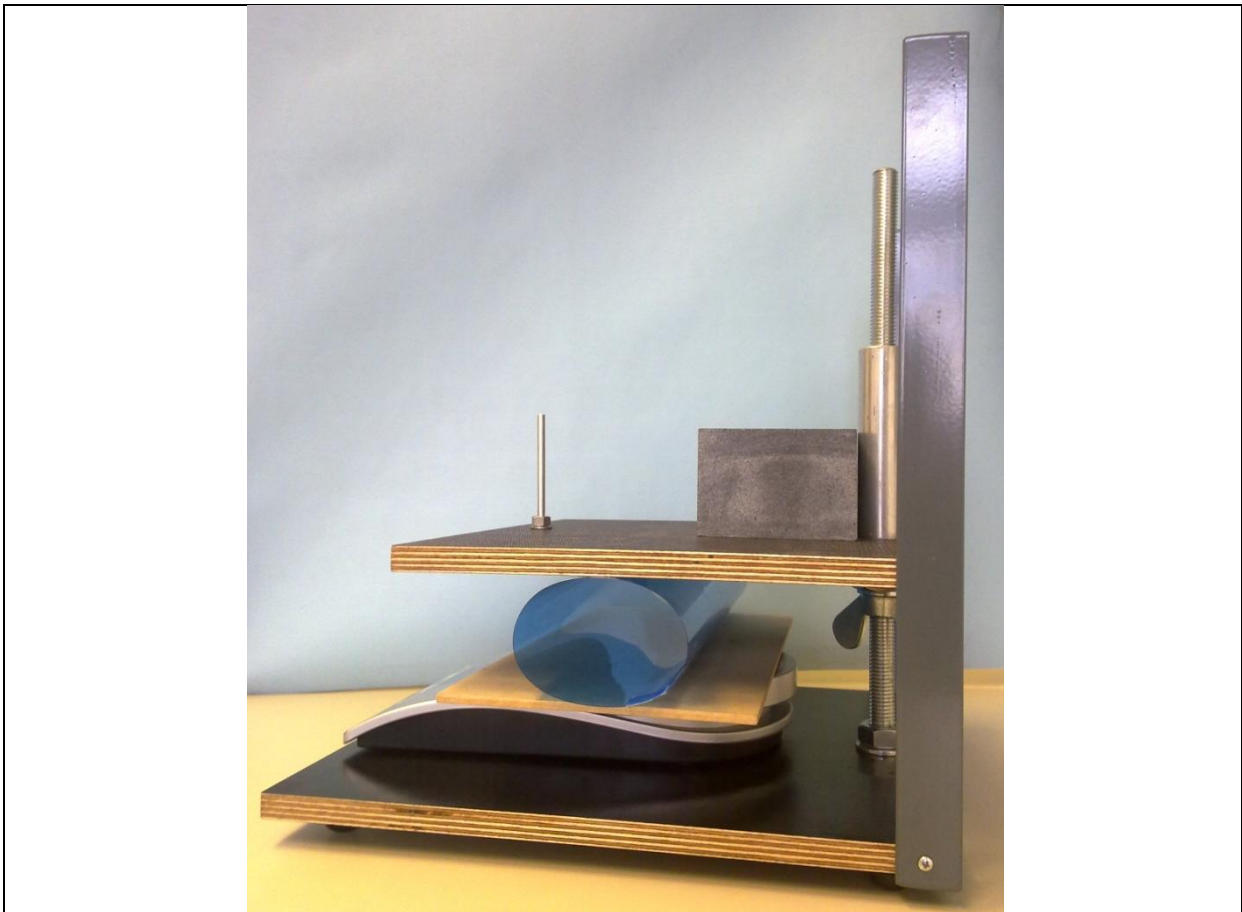

Figure 3. The photo of a setup for measuring the bending rigidity.

Tasks

1. Roll the blue foils into cylinders, one along the longer side, and the other along its shorter side; use the adhesive tape to fix them. The overlap of the sheet should be about 0.5 cm.
 - (a) Measure the dependence of the mass read by the scale on the separation between the plates of the press for each of the two cylinders. (1.9 points)
 - (b) Plot your measurements on appropriate graphs. Using the ruler and eye as the guide, draw lines through the points and determine the bending rigidities κ for the cylinders. Mark the region where the approximate relation (the stadium approximation) holds. Estimate the value of $\frac{R_0}{R_c}$ below which the stadium approximation holds; here R_c is the radius of the non-laden cylinder(s). (4.3 points)

The error analysis of the results is not required.

2. Measure the bending rigidity of a single colorless transparent foil. (2.8 points)
3. The bending rigidity κ depends on the Young's modulus Y of elasticity of the isotropic material, and the thickness d of the transparent foil according to

$\kappa = \frac{Yd^3}{12(1-\nu^2)},$	(3)
--------------------------------------	-----

where ν is the Poisson ratio for the material; for most materials $\nu \approx 1/3$. From the previous measurements, determine the Young's modulus of the blue and the colorless transparent foil. (1.0 points)

Exp. problem 1 – Answer sheets

Country code	Student code

Task 1		Points
(a)		

A Answer Sheets – Experimental Problem 1 – Elasticity

2/7

Country code	Student code

Task 1		Points
(a)		

A Answer Sheets – Experimental Problem 1 – Elasticity

3 / 7

Country code	Student code

Task 1	Points
(b)	

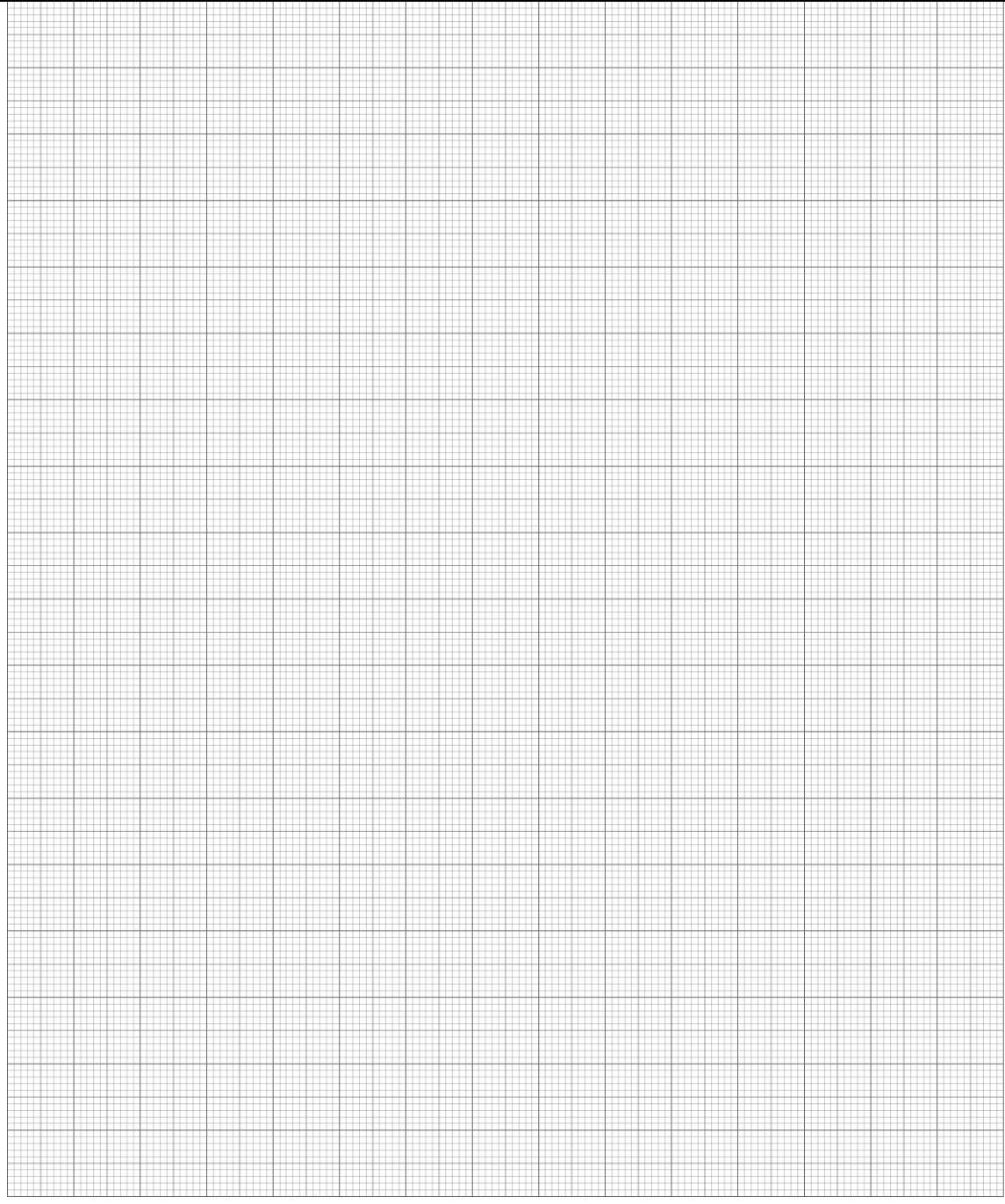

A Answer Sheets - Experimental Problem 1 - Elasticity

4 / 7

Country code	Student code

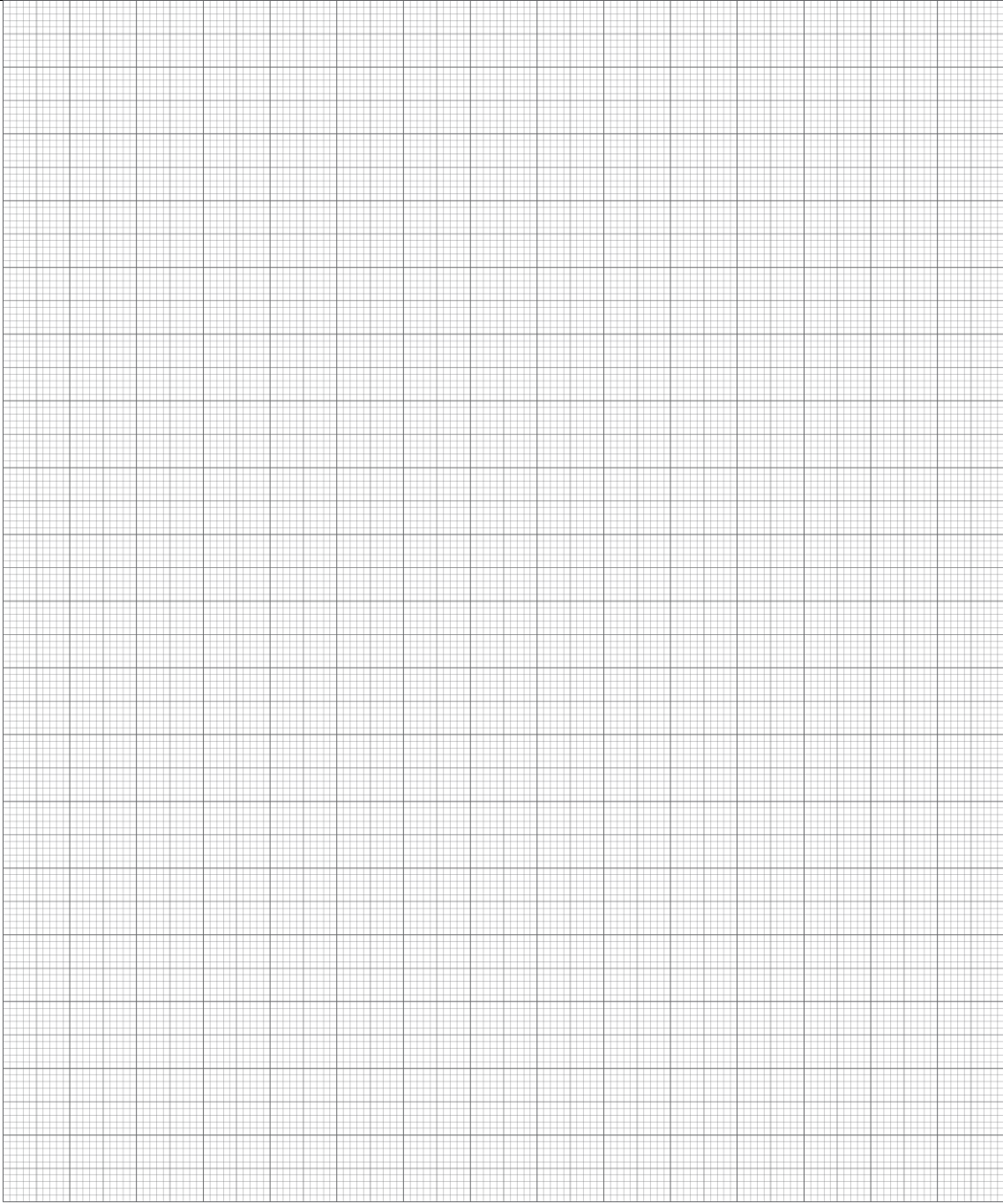
Task 1	Points
(b)	

A Answer Sheets – Experimental Problem 1 – Elasticity

5/7

Country code	Student code

Task 1		Points
(b)	$\kappa =$	
	$\kappa =$	
	$\frac{R_0}{R_c} \leq$	$\frac{R_0}{R_c} \leq$
Task 2		Points

Country code	Student code

Task 2

Points

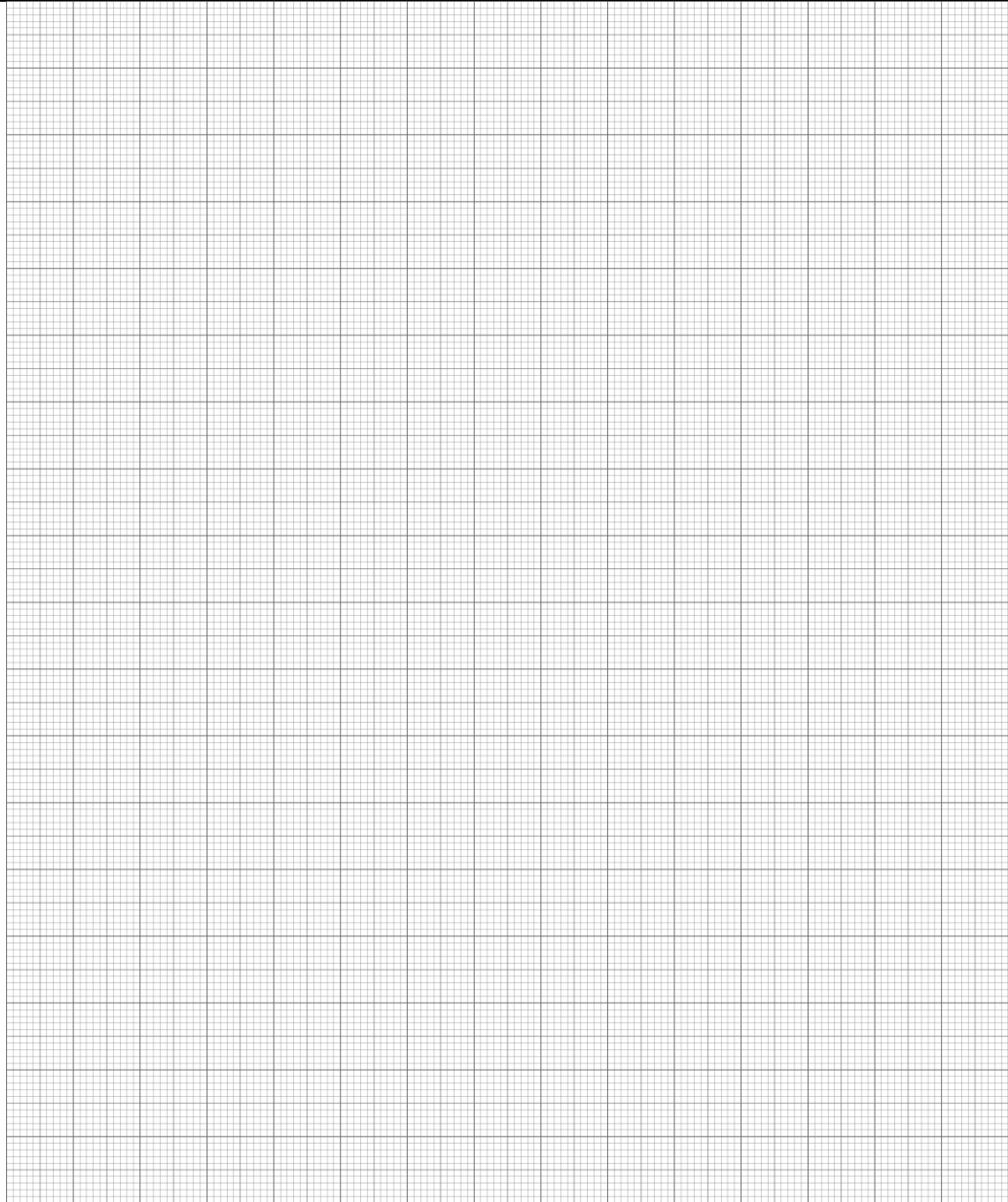

A Answer Sheets – Experimental Problem 1 – Elasticity

7/7

Country code	Student code

Task 2		Points
	$K =$	
Task 3		Points
	Young modulus of the blue foil:	
	Young modulus of the colorless foil:	
Total:		

Experimental problem 2

There are two experimental problems. The setup on your table is used for both problems. You have 5 hours to complete the entire task (1&2).

Experimental problem 2: Forces between magnets, concepts of stability and symmetry

Introduction

Electric current I circulating in a loop of area S creates a magnetic moment of magnitude $m = IS$ [see Fig. 1(a)]. A permanent magnet can be thought of as a collection of small magnetic moments of iron (Fe), each of which is analogous to the magnetic moment of a current loop. This (Ampère's) model of a magnet is illustrated in Fig. 1(b). The total magnetic moment is a sum of all small magnetic moments, and it points from the south to the northern pole.

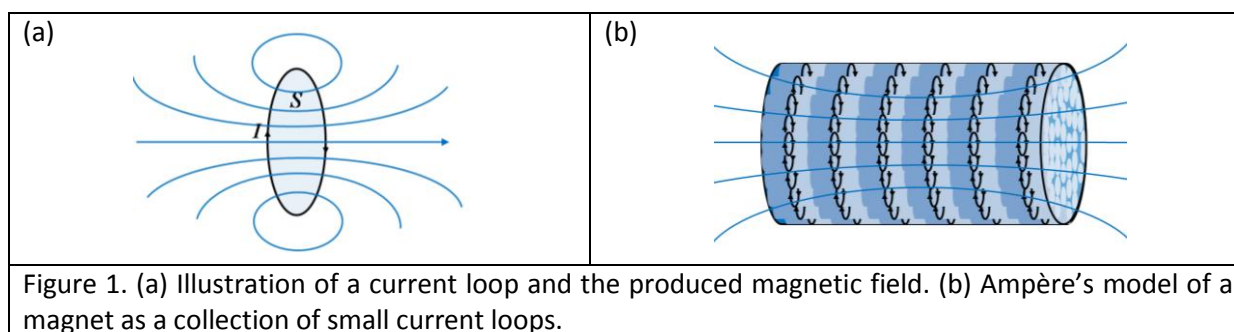
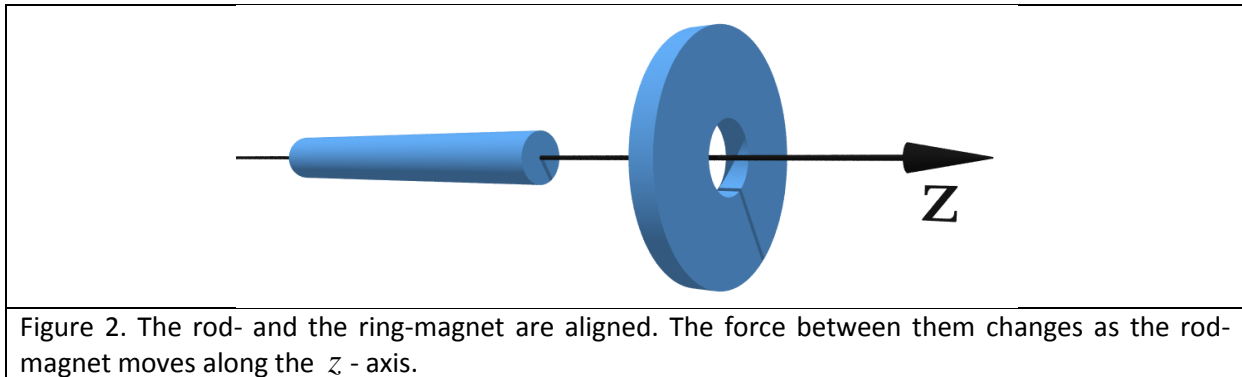

Figure 1. (a) Illustration of a current loop and the produced magnetic field. (b) Ampère's model of a magnet as a collection of small current loops.

Forces between magnets

To calculate the force between two magnets is a nontrivial theoretical task. It is known that like poles of two magnets repel, and unlike poles attract. The force between two current loops depends on the strengths of the currents in them, their shape, and their mutual distance. If we reverse the current in one of the loops, the force between them will be of the same magnitude, but of the opposite direction.

In this problem you experimentally investigate the forces between two magnets, the ring-magnet and the rod-magnet. We are interested in the geometry where the axes of symmetry of the two magnets coincide (see Fig. 2). The rod-magnet can move along the z -axis from the left, through the ring-magnet, and then towards the right (see Fig. 2). Among other tasks, you will be asked to measure the force between the magnets as a function of z . The origin $z = 0$ corresponds to the case when the centers of the magnets coincide.



To ensure motion of the rod-magnet along the axis of symmetry (z - axis), the ring-magnet is firmly embedded in a transparent cylinder, which has a narrow hole drilled along the z - axis. The rod-magnet is thus constrained to move along the z - axis through the hole (see Fig. 3). The magnetization of the magnets is along the z - axis. The hole ensures radial stability of the magnets.

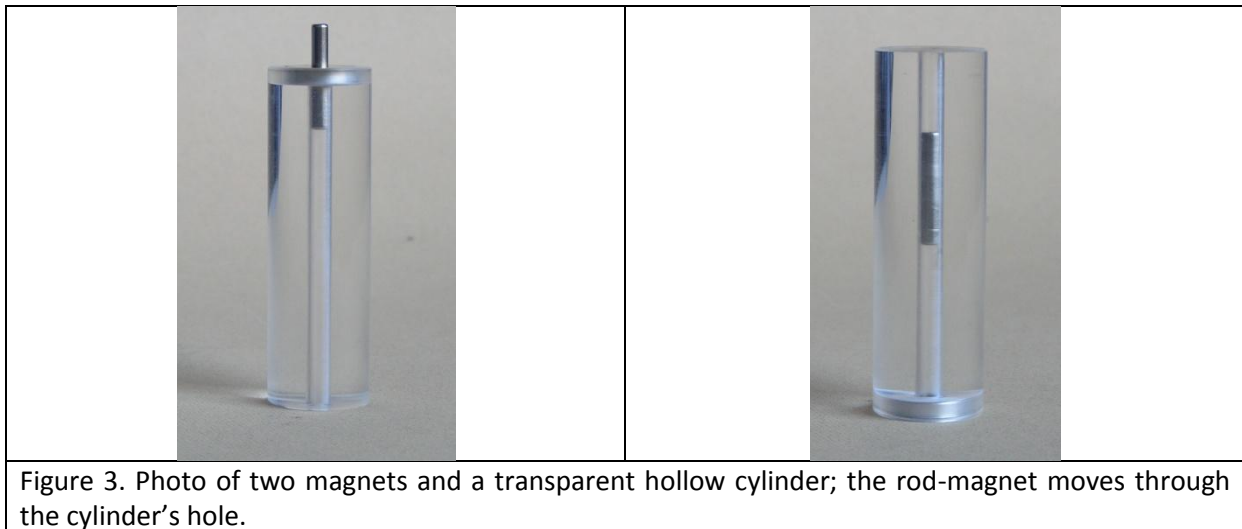

Experimental setup (2nd problem)

The following items (to be used for the 2nd problem) are on your desk:

1. Press (together with a stone block); see separate instructions if needed
2. Scale (measures mass up to 5000 g, it has TARA function, see separate instructions if needed)
3. A transparent hollow cylinder with a ring-magnet embedded in its side.
4. One rod-magnet.
5. One narrow wooden stick (can be used to push the rod magnet out of the cylinder).

The setup is to be used as in Fig. 4 to measure the forces between the magnets. The upper plate of the press needs to be turned up-side-down in comparison to the first experimental problem. The narrow Aluminum rod is used to press the rod-magnet through the hollow cylinder. The scale measures the force (mass). The upper plate of the press can be moved downwards and upwards by using a wing nut. **Important: The wing nut moves 2mm when rotated 360 degrees.**

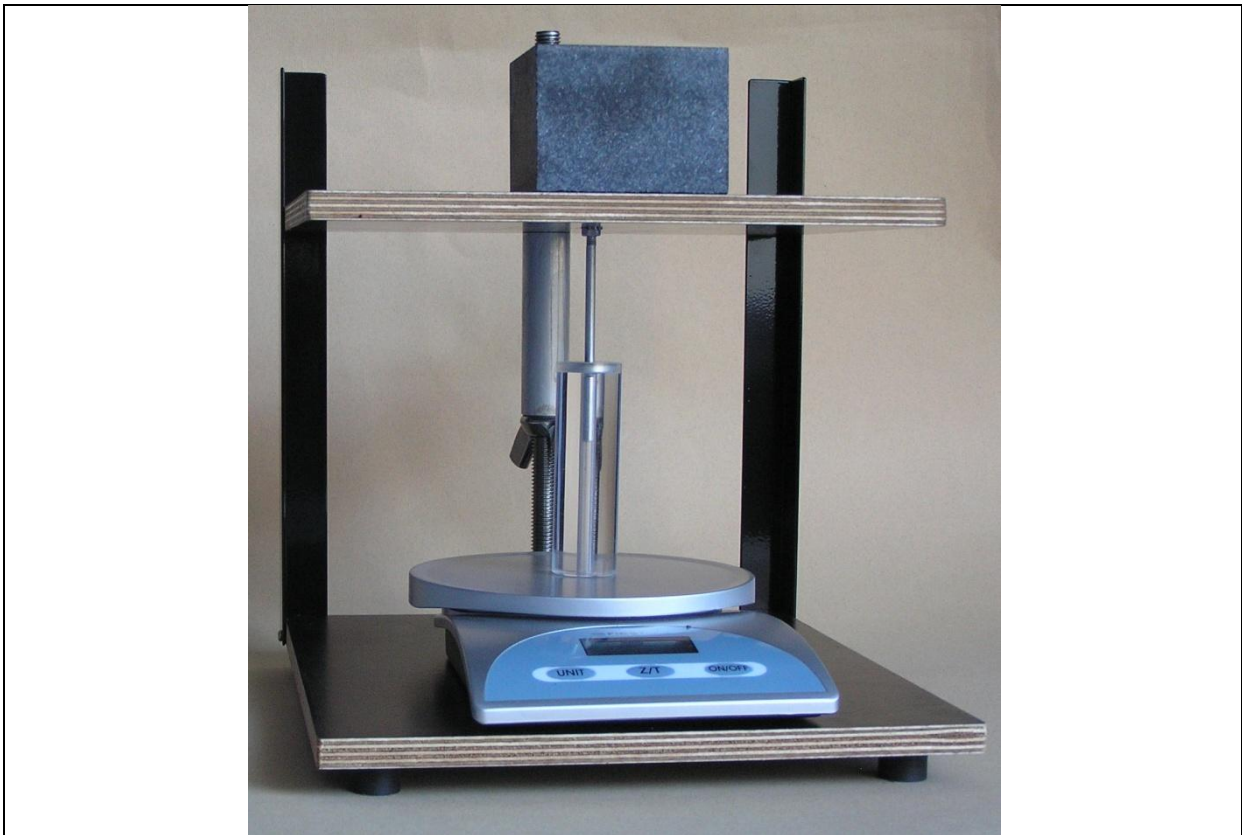

Figure 4. Photograph of the setup, and the way it should be used for measuring the force between the magnets.

Tasks

1. Determine qualitatively all equilibrium positions between the two magnets, assuming that the z - axis is positioned horizontally as in Fig. 2 , and draw them in the answer sheet. Label the equilibrium positions as stable (S)/unstable (U), and denote the like poles by shading, as indicated for one stable position in the answer sheet. You can do this Task by using your hands and a wooden stick. (2.5 points)
2. By using the experimental setup measure the force between the two magnets as a function of the z - coordinate. Let the positive direction of the z - axis point into the transparent cylinder (the force is positive if it points in the positive direction). For the configuration when the magnetic moments are parallel, denote the magnetic force by $F_{\uparrow\uparrow}(z)$, and when they are anti-parallel, denote the magnetic force by $F_{\uparrow\downarrow}(z)$. **Important: Neglect the mass of the rod-magnet (i.e., neglect gravity), and utilize the symmetries of the forces between magnets to measure different parts of the curves.** If you find any symmetry in the forces, write them in the answer sheets. Write the measurements on the answer sheets; beside every table schematically draw the configuration of magnets corresponding to each table (an example is given). (3.0 points)
3. By using the measurements from Task 2, use the millimeter paper to plot in detail the functional dependence $F_{\uparrow\uparrow}(z)$ for $z > 0$. Plot schematically the shapes of the curves $F_{\uparrow\uparrow}(z)$ and $F_{\uparrow\downarrow}(z)$ (along the positive and the negative z - axis). On each schematic graph

denote the positions of the stable equilibrium points, and sketch the corresponding configuration of magnets (as in Task 1). *(4.0 points)*

4. If we do not neglect the mass of the rod magnet, are there any qualitatively new stable equilibrium positions created when the z - axis is positioned vertically? If so, plot them on the answer sheet as in Task 1. *(0.5 points)*

Answer Sheets - Exp. Problem 2

Country code	Student code

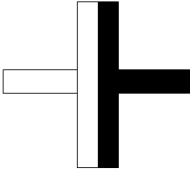
Task 1	Points	
	<p>S U</p> 	
	<p>S U</p>	
	<p>S U</p>	
	<p>S U</p>	
	<p>S U</p>	

A Answer Sheets – Experimental Problem 2 – Magnets

2 / 8

Country code	Student code

Task 1		Points
	S U	
	S U	
	S U	
	S U	
	S U	

Country code	Student code

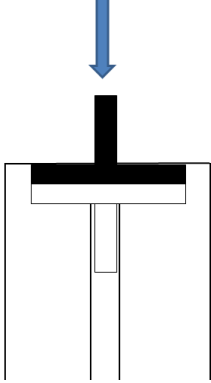
Task 2	Points
Write all symmetries that you find for the force between magnets:	
Configuration:  Measurements:	

A Answer Sheets – Experimental Problem 2 – Magnets

4 / 8

Country code	Student code

Task 2		Points

A Answer Sheets – Experimental Problem 2 – Magnets

5 / 8

Country code	Student code

Task 2		Points

A Answer Sheets - Experimental Problem 2 - Magnets

6 / 8

Country code	Student code

Task 3

Points

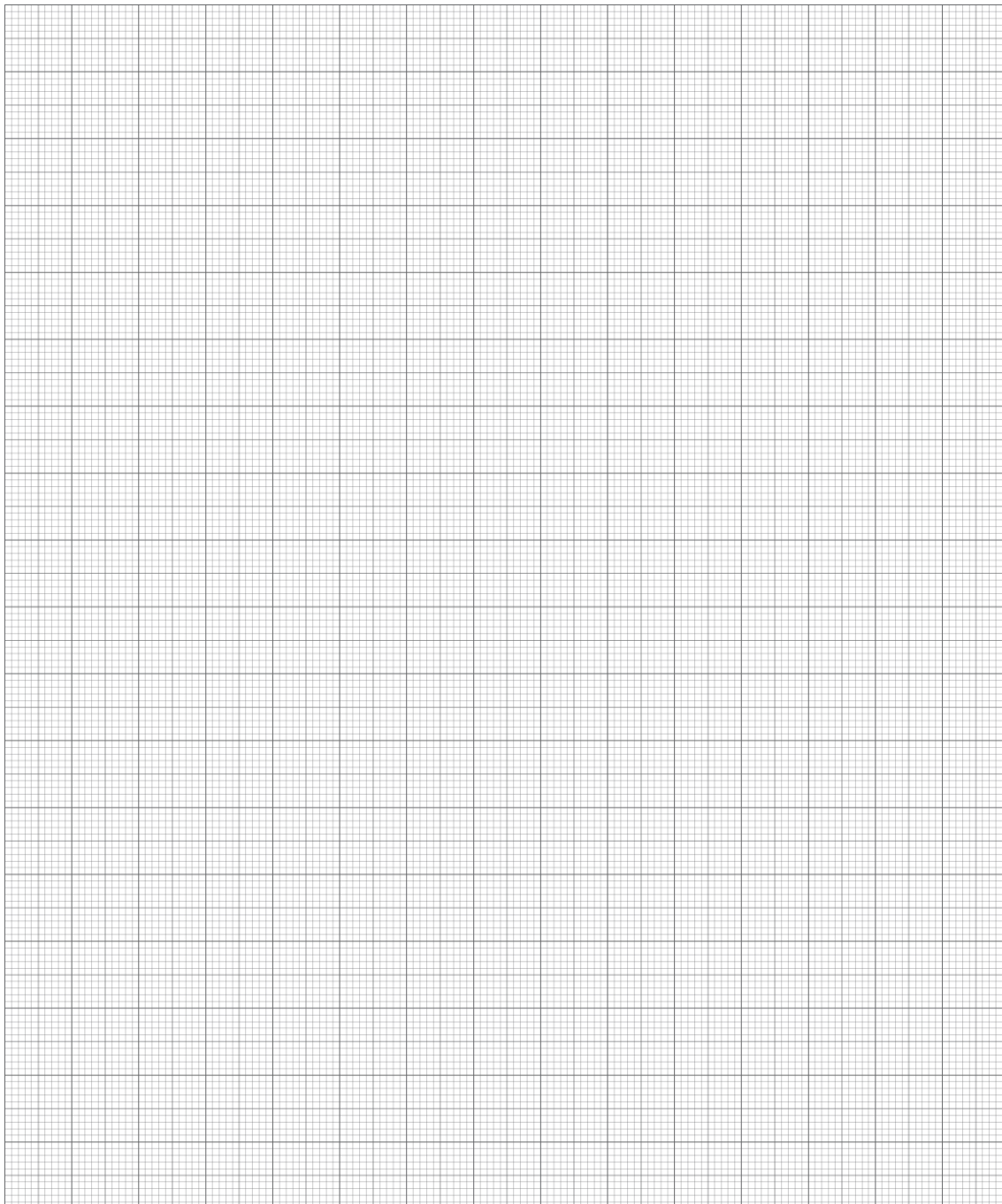

A Answer Sheets – Experimental Problem 2 – Magnets

7 / 8

Country code	Student code

Task 3		Points
	Schematic (hand drawn) plot of $F_{\uparrow\uparrow}(z)$	
	Schematic (hand drawn) plot of $F_{\uparrow\downarrow}(z)$	

A Answer Sheets – Experimental Problem 2 – Magnets

8 / 8

Country code	Student code

Task 4		Points
Total:		

Solution - Image of a charge

Solution of Task 1

Task 1a)

As the metallic sphere is grounded, its potential vanishes, $V=0$.

Task1b)

Let us consider an arbitrary point B on the surface of the sphere as depicted in Fig. 1.

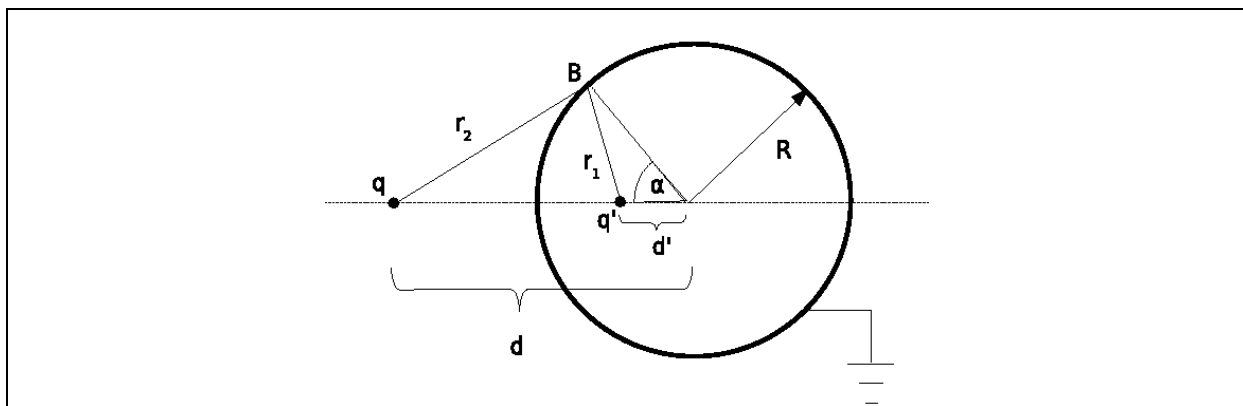

Fig 1. The potential at point B is zero.

The distance of point B from the charge q' is

$$r_1 = \sqrt{R^2 + d'^2 - 2Rd' \cos \alpha} \quad (1)$$

whereas the distance of the point B from the charge q is given with the expression

$$r_2 = \sqrt{R^2 + d^2 - 2Rd \cos \alpha} \quad (2)$$

The electric potential at the point B is

$$V = \frac{1}{4\pi\epsilon_0} \left(\frac{q}{r_2} + \frac{q'}{r_1} \right) \quad (3)$$

This potential must vanish,

$$\frac{q}{r_2} + \frac{q'}{r_1} = 0 \quad (4)$$

i.e. its numerical value is 0 V.

Combining (1), (2) and (3) we obtain

$R^2 + d^2 - 2Rd \cos \alpha = \left(\frac{q}{q'}\right)^2 (R^2 + d'^2 - 2Rd' \cos \alpha)$	(5)
---	-----

As the surface of the sphere must be equipotential, the condition (5) must be satisfied for every angle α what leads to the following results

$d^2 + R^2 = \left(\frac{q}{q'}\right)^2 (R^2 + d'^2)$	(6)
--	-----

and

$dR = \left(\frac{q}{q'}\right)^2 (d'R)$	(7)
--	-----

By solving of (6) and (7) we obtain the expression for the distance d' of the charge q' from the center of the sphere

$d' = \frac{R^2}{d}$	(8)
----------------------	-----

and the size of the charge q'

$q' = -q \frac{R}{d}$	(9)
-----------------------	-----

Task 1c)

Finally, the magnitude of force acting on the charge q is

$F = \frac{1}{4\pi\epsilon_0} \frac{q^2 R d}{(d^2 - R^2)^2}$	(10)
--	------

The force is apparently **attractive**.

Solution of Task 2

Task 2a)

The electric field at the point A amounts to

$$\vec{E}_A = \left(\frac{1}{4\pi\epsilon_0} \frac{q}{r^2} - \frac{1}{4\pi\epsilon_0} \frac{q \frac{R}{d}}{\left(r - d + \frac{R^2}{d}\right)^2} \right) \hat{r} \quad (11)$$

Task 2b)

For very large distances r we can apply approximate formula $(1+a)^{-2} \approx 1-2a$ to the expression (11) what leads us to

$$\vec{E}_A = \frac{1}{4\pi\epsilon_0} \frac{\left(1 - \frac{R}{d}\right) q}{r^2} \hat{r} - \frac{1}{4\pi\epsilon_0} \frac{2q \frac{R}{d} \left(d - \frac{R^2}{d}\right)}{r^3} \hat{r} \quad (12)$$

In general a grounded metallic sphere cannot completely screen a point charge q at a distance d (even in the sense that its electric field would decrease with distance faster than $1/r^2$) and the dominant dependence of the electric field on the distance r is as in standard Coulomb law.

Task 2c)

In the limit $d \rightarrow R$ the electric field at the point A vanishes and the grounded metallic sphere screens the point charge completely.

Solution of Task 3**Task 3a)**

Let us consider a configuration as in Fig. 2.

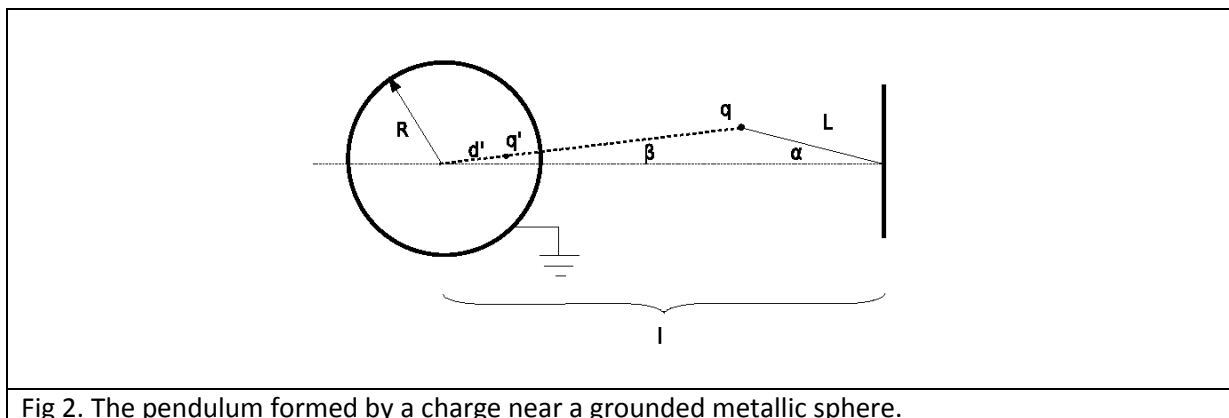

Fig 2. The pendulum formed by a charge near a grounded metallic sphere.

The distance of the charge q from the center of the sphere is

$$d = \sqrt{l^2 + L^2 - 2lL \cos \alpha} \quad (13)$$

The magnitude of the electric force acting on the charge q is

$$F = \frac{1}{4\pi\epsilon_0} \frac{qq'}{(d - d')^2} = \frac{1}{4\pi\epsilon_0} \frac{q^2 R d}{(d^2 - R^2)^2} \quad (14)$$

From which we have

$$F = \frac{1}{4\pi\epsilon_0} \frac{q^2 R \sqrt{l^2 + L^2 - 2lL \cos \alpha}}{(l^2 + L^2 - 2lL \cos \alpha - R^2)^2} \quad (15)$$

Task 3b)

The direction of the vector of the electric force (17) is described in Fig. 3.

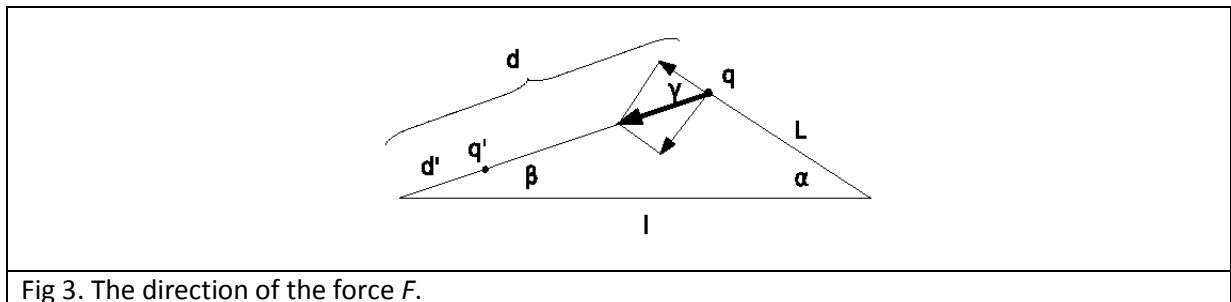

Fig 3. The direction of the force F .

The angles α and β are related as

$$L \sin \alpha = d \sin \beta \quad (16)$$

whereas for the angle γ the relation $\gamma = \alpha + \beta$ is valid. The component of the force perpendicular to the thread is $F \sin \gamma$, that is ,

$$F_{\perp} = \frac{1}{4\pi\epsilon_0} \frac{q^2 R \sqrt{l^2 + L^2 - 2lL \cos \alpha}}{(l^2 + L^2 - 2lL \cos \alpha - R^2)^2} \sin(\alpha + \beta)$$

where

$$\beta = \arcsin\left(\frac{L}{\sqrt{l^2 + L^2 - 2lL \cos \alpha}} \sin \alpha\right) \quad (17)$$

Task 3c)

The equation of motion of the mathematical pendulum is

$mL\ddot{\alpha} = -F_{\perp}$	(18)
--------------------------------	------

As we are interested in small oscillations, the angle α is small, i.e. for its value in radians we have α much smaller than 1. For a small value of argument of trigonometric functions we have approximate relations $\sin x \approx x$ and $\cos x \approx 1 - x^2/2$. So for small oscillations of the pendulum we have $\beta \approx \alpha L/(l - L)$ and $\gamma \approx l\alpha/(l - L)$.

Combining these relations with (13) we obtain

$mL \frac{d^2 \alpha}{dt^2} + \frac{1}{4\pi\epsilon_0} \frac{q^2 R d}{(d^2 - R^2)^2} \left(1 + \frac{L}{d}\right) \alpha = 0$	(19)
---	------

Where $d = l - L$ what leads to

$\omega = \frac{q}{d^2 - R^2} \sqrt{\frac{Rd}{4\pi\epsilon_0} \frac{1}{mL} \left(1 + \frac{L}{d}\right)} =$ $= \frac{q}{(l - L)^2 - R^2} \sqrt{\frac{Rl}{4\pi\epsilon_0} \frac{1}{mL}}$	(20)
--	------

Solution of Task 4

First we present a solution based on the definition of the electrostatic energy of a collection of charges.

Task 4a)

The total energy of the system can be separated into the electrostatic energy of interaction of the external charge with the induced charges on the sphere, $E_{el,1}$, and the electrostatic energy of mutual interaction of charges on the sphere, $E_{el,2}$, i.e.

$E_{el} = E_{el,1} + E_{el,2}$	(21)
--------------------------------	------

Let there be N charges induced on the sphere. These charges q_j are located at points $\vec{r}_j, j = 1, \dots, N$ on the sphere. We use the definition of the image charge, i.e., the potential on the surface of the sphere from the image charge is identical to the potential arising from the induced charges:

$\frac{q'}{ \vec{r} - \vec{d}' } = \sum_{j=1}^N \frac{q_j}{ \vec{r}_j - \vec{r} },$	(22)
---	------

where \vec{r} is a vector on the sphere and \vec{d}' denotes the vector position of the image charge. When \vec{r} coincides with some \vec{r}_i , then we just have

$\frac{q'}{ \vec{r}_i - \vec{d}' } = \sum_{\substack{j=1 \\ j \neq i}}^N \frac{q_j}{ \vec{r}_j - \vec{r}_i }.$	(23)
--	------

From the requirement that the potential on the surface of the sphere vanishes we have

$\frac{q'}{ \vec{r} - \vec{d}' } + \frac{q}{ \vec{r} - \vec{d} } = 0,$	(24)
--	------

where \vec{d} denotes the vector position of the charge \vec{q} (\vec{r} is on the sphere).

For the interaction of the external charge with the induced charges on the sphere we have

$E_{el,1} = \frac{q}{4\pi\epsilon_0} \sum_{i=1}^N \frac{q_i}{ \vec{r}_i - \vec{d} } = \frac{1}{4\pi\epsilon_0} \frac{qq'}{ \vec{d}' - \vec{d} } = \frac{1}{4\pi\epsilon_0} \frac{qq'}{d - d'} = -\frac{1}{4\pi\epsilon_0} \frac{q^2 R}{d^2 - R^2}$	(25)
--	------

Here the first equality is the definition of this energy as the sum of interactions of the charge q with each of the induced charges on the surface of the sphere. The second equality follows from (21).

In fact, the interaction energy $E_{el,1}$ follows directly from the definition of an image charge.

Task 4b)

The energy of mutual interactions of induced charges on the surface of the sphere is given with

$$\begin{aligned}
 E_{el,2} &= \frac{1}{2} \frac{1}{4\pi\epsilon_0} \sum_{i=1}^N \sum_{\substack{j=1 \\ j \neq i}}^N \frac{q_i q_j}{|\vec{r}_i - \vec{r}_j|} \\
 &= \frac{1}{2} \frac{1}{4\pi\epsilon_0} \sum_{i=1}^N q_i \frac{q'}{|\vec{r}_i - \vec{d}'|} = \\
 &= -\frac{1}{2} \frac{1}{4\pi\epsilon_0} \sum_{i=1}^N q_i \frac{q}{|\vec{r}_i - \vec{d}|} = \\
 &= -\frac{1}{2} \frac{1}{4\pi\epsilon_0} \frac{qq'}{|\vec{d}' - \vec{d}|} = -\frac{1}{2} \frac{1}{4\pi\epsilon_0} \frac{qq'}{d - d'} = -\frac{1}{2} \frac{1}{4\pi\epsilon_0} \frac{q^2 R}{d^2 - R^2}
 \end{aligned} \tag{26}$$

Here the second line is obtained using (22). From the second line we obtain the third line applying (23), whereas from the third line we obtain the fourth using (22) again.

Task 4c)

Combining expressions (19) and (20) with the quantitative results for the image charge we finally obtain the total energy of electrostatic interaction

$$E_{el}(d) = -\frac{1}{2} \frac{1}{4\pi\epsilon_0} \frac{q^2 R}{d^2 - R^2} \tag{27}$$

An alternative solution follows from the definition of work. By knowing the integral

$$\int_d^\infty \frac{xdx}{(x^2 - R^2)^2} = \frac{1}{2} \frac{1}{d^2 - R^2} \tag{28}$$

We can obtain the total energy in the system by calculating the work needed to bring the charge q from infinity to the distance d from the center of the sphere:

$$\begin{aligned}
 E_{el}(d) &= -\int_\infty^d F(\vec{x})d\vec{x} = \int_d^\infty F(\vec{x})d\vec{x} = \\
 &= \int_d^\infty (-) \frac{1}{4\pi\epsilon_0} \frac{q^2 R x}{(x^2 - R^2)^2} dx = \\
 &= -\frac{1}{2} \frac{1}{4\pi\epsilon_0} \frac{q^2 R}{d^2 - R^2}
 \end{aligned} \tag{29}$$

This solves Task 4c).

The electrostatic energy between the charge q and the sphere must be equal to the energy between the charges q and q' according to the definition of the image charge:

$E_{el,1} = \frac{1}{4\pi\epsilon_0} \frac{qq'}{(d-d')} = -\frac{1}{4\pi\epsilon_0} \frac{q^2 R}{d^2 - R^2}$	(30)
--	------

This solves Task 4a).

From this we immediately have that the electrostatic energy among the charges on the sphere is:

$E_{el,2} = \frac{1}{2} \frac{1}{4\pi\epsilon_0} \frac{q^2 R}{d^2 - R^2}.$	(31)
--	------

This solves Task 4b).

Solution - Chimney physics

This problem was inspired and posed by using the following two references:

- W.W. Christie, *Chimney design and theory*, D. Van Nostrand Company, New York, 1902.
- J. Schlaich, R. Bergermann, W. Schiel, G. Weinrebe, *Design of Commercial Solar Updraft Tower Systems — Utilization of Solar Induced Convective Flows for Power Generation*, Journal of Solar Energy Engineering 127, 117 (2005).

Solution of Task 1

- a) What is the minimal height of the chimney needed in order that the chimney functions efficiently, so that it can release all of the produced gas in the atmosphere?

Let $p(z)$ denote the pressure of air at height z ; then, according to one of the assumptions $p(z) = p(0) - \rho_{\text{Air}}gz$, where $p(0)$ is the atmospheric pressure at zero altitude.

Throughout the chimney the Bernoulli law applies, that is, we can write

$\frac{1}{2} \rho_{\text{Smoke}} v(z)^2 + \rho_{\text{Smoke}}gz + p_{\text{Smoke}}(z) = \text{const.},$	(1)
---	-----

where $p_{\text{Smoke}}(z)$ is the pressure of smoke at height z , ρ_{Smoke} is its density, and $v(z)$ denotes the velocity of smoke; here we have used the assumption that the density of smoke does not vary throughout the chimney. Now we apply this equation at two points, (i) in the furnace, that is at point $z = -\varepsilon$, where ε is a negligibly small positive number, and (ii) at the top of the chimney where $z = h$ to obtain:

$\frac{1}{2} \rho_{\text{Smoke}} v(h)^2 + \rho_{\text{Smoke}}gh + p_{\text{Smoke}}(h) \approx p_{\text{Smoke}}(-\varepsilon)$	(2)
---	-----

On the right hand side we have used the assumption that the velocity of gases in the furnace is negligible (and also $-\rho_{\text{Smoke}}g\varepsilon \approx 0$).

We are interested in the minimal height at which the chimney will operate. The pressure of smoke at the top of the chimney has to be equal or larger than the pressure of air at altitude h ; for minimal height of the chimney we have $p_{\text{Smoke}}(h) \approx p(h)$. In the furnace we can use $p_{\text{Smoke}}(-\varepsilon) \approx p(0)$. The Bernoulli law applied in the furnace and at the top of the chimney [Eq. (2)] now reads

$\frac{1}{2} \rho_{\text{Smoke}} v(h)^2 + \rho_{\text{Smoke}}gh + p(h) \approx p(0).$	(3)
---	-----

From this we get

$v(h) = \sqrt{2gh \left(\frac{\rho_{\text{Air}}}{\rho_{\text{Smoke}}} - 1 \right)}.$	(4)
---	-----

The chimney will be efficient if all of its products are released in the atmosphere, i.e.,

$v(h) \geq \frac{B}{A},$	(5)
--------------------------	-----

from which we have

$h \geq \frac{B^2}{A^2} \frac{1}{2g} \frac{1}{\frac{\rho_{Air}}{\rho_{Smoke}} - 1}.$	(6)
--	-----

We can treat the smoke in the furnace as an ideal gas (which is at atmospheric pressure $p(0)$ and temperature T_{Smoke}). If the air was at the same temperature and pressure it would have the same density according to our assumptions. We can use this to relate the ratio $\rho_{Air} / \rho_{Smoke}$ to T_{Smoke} / T_{Air} that is,

$\frac{\rho_{Air}}{\rho_{Smoke}} = \frac{T_{Smoke}}{T_{Air}},$ and finally	(7)
--	-----

$h \geq \frac{B^2}{A^2} \frac{1}{2g} \frac{T_{Air}}{T_{Smoke} - T_{Air}} = \frac{B^2}{A^2} \frac{1}{2g} \frac{T_{Air}}{\Delta T}.$	(8)
--	-----

For minimal height of the chimney we use the equality sign.

b) How high should the chimney in warm regions be?

$\frac{h(30)}{h(-30)} = \frac{\frac{T(30)}{T_{Smoke} - T(30)}}{\frac{T(-30)}{T_{Smoke} - T(-30)}}; h(30) = 145m.$	(9)
---	-----

c) How does the velocity of the gases vary along the height of the chimney?

The velocity is constant,

$v = \sqrt{2gh \left(\frac{\rho_{Air}}{\rho_{Smoke}} - 1 \right)} = \sqrt{2gh \left(\frac{T_{Smoke}}{T_{Air}} - 1 \right)} = \sqrt{2gh \frac{\Delta T}{T_{Air}}}.$	(10)
--	------

This can be seen from the equation of continuity $Av = \text{const.}$ (ρ_{Smoke} is constant). It has a sudden jump from approximately zero velocity to this constant value when the gases enter the chimney from the furnace. In fact, since the chimney operates at minimal height this constant is equal to B , that is $v = B/A$.

d) At some height z , from the Bernoulli equation one gets

$p_{smoke}(z) = p(0) - (\rho_{Air} - \rho_{Smoke})gh - \rho_{Smoke}gz.$	(11)
---	------

Thus the pressure of smoke suddenly changes as it enters the chimney from the furnace and acquires velocity.

Solution of Task 2

a) The kinetic energy of the hot air released in a time interval Δt is

$E_{kin} = \frac{1}{2} (Av\Delta t\rho_{Hot})v^2 = Av\Delta t\rho_{Hot}gh\frac{\Delta T}{T_{Atm}},$	(12)
---	------

Where the index “Hot” refer to the hot air heated by the Sun. If we denote the mass of the air that exits the chimney in unit time with $w = Av\rho_{Hot}$, then the power which corresponds to kinetic energy above is

$P_{kin} = wgh\frac{\Delta T}{T_{Air}}.$	(13)
--	------

This is the maximal power that can be obtained from the kinetic energy of the gas flow.

The Sun power used to heat the air is

$P_{Sun} = GS = wc\Delta T.$	(14)
------------------------------	------

The efficiency is evidently

$\eta = \frac{P_{kin}}{P_{Sun}} = \frac{gh}{cT_{Atm}}.$	(15)
---	------

b) The change is apparently linear.

Solution of Task 3

a) The efficiency is

$\eta = \frac{gh}{cT_{Atm}} = 0.0064 = 0.64\%.$	(16)
---	------

b) The power is

$P = GS\eta = G(D/2)^2\pi\eta = 45\text{ kW}.$	(17)
--	------

c) If there are 8 sunny hours per day we get 360kWh.

Solution of Task 4

The result can be obtained by expressing the mass flow of air w as

$w = Av\rho_{Hot} = A\sqrt{2gh\frac{\Delta T}{T_{Air}}}\rho_{Hot}$	(18)
--	------

$w = \frac{GS}{c\Delta T}$	(19)
----------------------------	------

which yields

$\Delta T = \left(\frac{G^2 S^2 T_{Atm}}{A^2 c^2 \rho_{Hot}^2 2gh}\right)^{1/3} \approx 9.1\text{ K}.$	(20)
--	------

From this we get

$$w = 760 \text{ kg/s.}$$

(21)

Solution - model of an atomic nucleus

Solution of Task 1

- a) In the SC-system, in each of 8 corners of a given cube there is one unit (atom, nucleon, etc.), but it is shared by 8 neighboring cubes – this gives a total of one nucleon per cube. If nucleons are touching, as we assume in our simplified model, then $a = 2r_N$ is the cube edge length a . The volume of one nucleon is then

$$V_N = \frac{4}{3} r_N^3 \pi = \frac{4}{3} \left(\frac{a}{2}\right)^3 \pi = \frac{4a^3}{3 \cdot 8} \pi = \frac{\pi}{6} a^3 \quad (1)$$

from which we obtain

$$f = \frac{V_N}{a^3} = \frac{\pi}{6} \approx 0.52 \quad (2)$$

- b) The mass density of the nucleus is:

$$\rho_m = f \frac{m_N}{V_N} = 0.52 \cdot \frac{1.67 \cdot 10^{-27}}{4/3 \cdot (0.85 \cdot 10^{-15})^3 \pi} \approx 3.40 \cdot 10^{17} \frac{\text{kg}}{\text{m}^3}. \quad (4)$$

Taking into account the approximation that the number of protons and neutrons is

- c) approximately equal, for charge density we get:

$$\rho_c = \frac{f}{2} \frac{e}{V_N} = \frac{0.52}{2} \cdot \frac{1.6 \cdot 10^{-19}}{4/3 \cdot (0.85 \cdot 10^{-15})^3 \pi} \approx 1.63 \cdot 10^{25} \frac{\text{C}}{\text{m}^3} \quad (5)$$

The number of nucleons in a given nucleus is A . The total volume occupied by the nucleus is:

$$V = \frac{AV_N}{f}, \quad (6)$$

which gives the following relation between radii of nucleus and the number of nucleons:

$$R = r_N \left(\frac{A}{f}\right)^{1/3} = \frac{r_N}{f^{1/3}} A^{1/3} = \frac{0.85}{0.52^{1/3}} A^{1/3} = 1.06 \text{ fm} \cdot A^{1/3}. \quad (7)$$

The numerical constant (1.06 fm) in the equation above will be denoted as r_0 in the sequel.

Solution of Task 2

First one needs to estimate the number of surface nucleons. The surface nucleons are in a spherical shell of width $2r_N$ at the surface. The volume of this shell is

$ \begin{aligned} V_{surface} &= \frac{4}{3}R^3\pi - \frac{4}{3}(R - 2r_N)^3\pi = \\ &= \frac{4}{3}R^3\pi - \frac{4}{3}R^3\pi + \frac{4}{3}\pi 3R^2 2r_N - \frac{4}{3}\pi 3R 4r_N^2 + \frac{4}{3}\pi 8r_N^3 \\ &= 8\pi R r_N (R - 2r_N) + \frac{4}{3}\pi 8r_N^3 = \\ &= 8\pi(R^2 r_N - 2Rr_N^2 + \frac{4}{3}r_N^3) \end{aligned} $	(8)
---	-----

The number of surface nucleons is:

$ \begin{aligned} A_{surface} &= f \frac{V_{surface}}{V_N} = f \frac{8\pi(R^2 r_N - 2Rr_N^2 + \frac{4}{3}r_N^3)}{\frac{4}{3}r_N^3\pi} = \\ &= f 6 \left(\left(\frac{R}{r_N} \right)^2 - 2 \left(\frac{R}{r_N} \right) + \frac{4}{3} \right) = \\ &= f 6 \left(\left(\frac{A}{f} \right)^{2/3} - 2 \left(\frac{A}{f} \right)^{1/3} + \frac{4}{3} \right) = \\ &= 6f^{1/3} A^{2/3} - 12f^{2/3} A^{1/3} + 8f = \\ &= 6^{2/3} \pi^{1/3} A^{2/3} - 2 \cdot 6^{1/3} \pi^{2/3} A^{1/3} + \frac{4}{3} \pi \approx \\ &\approx 4.84A^{2/3} - 7.80A^{1/3} + 4.19. \end{aligned} $	(9)
--	-----

The binding energy is now:

$ \begin{aligned} E_b &= (A - A_{surface})a_V + A_{surface} \frac{a_V}{2} = \\ &= Aa_V - A_{surface} \frac{a_V}{2} = \\ &= Aa_V - (3f^{1/3} A^{2/3} - 6f^{2/3} A^{1/3} + 4f)a_V = \\ &= Aa_V - 3f^{1/3} A^{2/3} a_V + 6f^{2/3} A^{1/3} a_V - 4fa_V = \\ &= (15.8A - 38.20A^{2/3} + 61.58A^{1/3} - 33.09)\text{MeV} \end{aligned} $	(10)
--	------

Solution of Task 3 - Electrostatic (Coulomb) effects on the binding energy

a) Replacing Q_0 with Ze gives the electrostatic energy of the nucleus as:

$U_c = \frac{3(Ze)^2}{20\pi\epsilon_0 R} = \frac{3Z^2 e^2}{20\pi\epsilon_0 R}$	(12)
--	------

The fact that each proton is not acting upon itself is taken into account by replacing Z^2 with $Z(Z-1)$:

$U_c = \frac{3Z(Z-1)e^2}{20\pi\epsilon_0 R} \quad (13)$	
---	--

b) In the formula for the electrostatic energy we should replace R with $r_N f^{-1/3} A^{1/3}$ to obtain

$\begin{aligned} \Delta E_b &= -\frac{3e^2 f^{1/3}}{20\pi\epsilon_0 r_N} \frac{Z(Z-1)}{A^{1/3}} = -\frac{Z(Z-1)}{A^{1/3}} \cdot 1.31 \times 10^{-13} \text{ J} \\ &= -\frac{Z(Z-1)}{A^{1/3}} \cdot 0.815 \text{ MeV} \approx -0.204 A^{5/3} \text{ MeV} + 0.409 A^{2/3} \text{ MeV} \end{aligned} \quad (14)$	
---	--

where $Z \approx A/2$ has been used. The Coulomb repulsion reduces the binding energy, hence the negative sign before the first (main) term. The complete formula for binding energy now gives:

$E_b = Aa_v - 3f^{1/3} A^{2/3} a_v + 6f^{2/3} A^{1/3} a_v - 4fa_v - \frac{3e^2 f^{1/3}}{20\pi\epsilon_0 r_N} \left(\frac{A^{5/3}}{4} - \frac{A^{2/3}}{2} \right) \quad (15)$	
---	--

Solution of Task 4 - Fission of heavy nuclei

a) The kinetic energy comes from the difference of binding energies (2 small nuclei – the original large one) and the Coulomb energy between two smaller nuclei (with $Z/2=A/4$ nucleons each):

$\begin{aligned} E_{kin}(d) &= 2E_b\left(\frac{A}{2}\right) - E_b(A) - \frac{1}{4\pi\epsilon_0} \frac{A^2 e^2}{4 \cdot 4 \cdot d} = \\ &= -3f^{1/3} A^{2/3} a_v (2^{1/3} - 1) + 6f^{2/3} A^{1/3} a_v (2^{2/3} - 1) \\ &\quad - 4fa_v - \frac{3e^2 f^{1/3}}{20\pi\epsilon_0 r_N} \left[\frac{A^{5/3}}{4} (2^{-2/3} - 1) - \frac{A^{2/3}}{2} (2^{1/3} - 1) \right] \\ &\quad - \frac{1}{4\pi\epsilon_0} \frac{A^2 e^2}{16d} \end{aligned} \quad (16)$	
--	--

(notice that the first term, Aa_v , cancels out).

b) The kinetic energy when $d = 2R(A/2)$ is given with:

$\begin{aligned} E_{kin} &= 2E_b\left(\frac{A}{2}\right) - E_b(A) - \frac{1}{4\pi\epsilon_0} \frac{2^{1/3} A^2 e^2}{16 \cdot 2r_N A^{1/3} f^{-1/3}} = \\ &= -3f^{1/3} A^{2/3} a_v (2^{1/3} - 1) + 6f^{2/3} A^{1/3} a_v (2^{2/3} - 1) \\ &\quad - 4fa_v - \frac{e^2 f^{1/3}}{\pi\epsilon_0 r_N} \left[\frac{3}{80} (2^{-2/3} - 1) + \frac{2^{1/3}}{128} \right] A^{5/3} - \frac{e^2 f^{1/3}}{\pi\epsilon_0 r_N} \left[\frac{3}{40} (2^{1/3} - 1) \right] A^{2/3} = \\ &= (0.02203A^{5/3} - 10.0365A^{2/3} + 36.175A^{1/3} - 33.091) \text{ MeV} \end{aligned} \quad (17)$	
--	--

Numerically one gets:

$$A=100 \dots E_{kin} = -33.95 \text{ MeV,}$$

$$A=150 \dots E_{kin} = -30.93 \text{ MeV,}$$

$$A=200 \dots E_{kin} = -14.10 \text{ MeV},$$

$$A=250 \dots E_{kin} = +15.06 \text{ MeV}.$$

In our model, fission is possible when $E_{kin}(d = 2R(A/2)) \geq 0$. From the numerical evaluations given above, one sees that this happens approximately halfway between $A=200$ and $A=250$ – a rough estimate would be $A \approx 225$. Precise numerical evaluation of the equation:

$E_{kin} = (0.02203A^{5/3} - 10.0365A^{2/3} + 36.175A^{1/3} - 33.091)\text{MeV} \geq 0$	(18)
---	------

gives that for $A \geq 227$ fission is possible.

Solution of Task 5 – Transfer reactions

Task 5a) This part can be solved by using either non-relativistic or relativistic kinematics.

Non-relativistic solution

First one has to find the amount of mass transferred to energy in the reaction (or the energy equivalent, so-called Q-value):

$\begin{aligned} \Delta m &= (\text{total mass})_{\text{after reaction}} - (\text{total mass})_{\text{before reaction}} = \\ &= (57.93535 + 12.00000) \text{ a.m.u.} - (53.93962 + 15.99491) \text{ a.m.u.} = \\ &= 0.00082 \text{ a.m.u.} = \\ &= 1.3616 \cdot 10^{-30} \text{ kg.} \end{aligned}$	(19)
---	------

Using the Einstein formula for equivalence of mass and energy, we get:

$\begin{aligned} Q &= (\text{total kinetic energy})_{\text{after reaction}} - (\text{total kinetic energy})_{\text{before reaction}} = \\ &= -\Delta m \cdot c^2 = \\ &= -1.3616 \cdot 10^{-30} \cdot 299792458^2 = -1.2237 \cdot 10^{-13} \text{ J} \end{aligned}$	(20)
---	------

Taking into account that 1 MeV is equal to $1.602 \cdot 10^{-13}$ J, we get:

$Q = -1.2237 \cdot 10^{-13} / 1.602 \cdot 10^{-13} = -0.761 \text{ MeV}$	(21)
--	------

This exercise is now solved using the laws of conservation of energy and momentum. The latter gives (we are interested only for the case when ^{12}C and ^{16}O are having the same direction so we don't need to use vectors):

$m(^{16}\text{O})v(^{16}\text{O}) = m(^{12}\text{C})v(^{12}\text{C}) + m(^{58}\text{Ni})v(^{58}\text{Ni})$	(22)
--	------

while the conservation of energy gives:

$E_k(^{16}\text{O}) + Q = E_k(^{12}\text{C}) + E_k(^{58}\text{Ni}) + E_x(^{58}\text{Ni})$	(23)
---	------

where $E_x(^{58}\text{Ni})$ is the excitation energy of ^{58}Ni , and Q is calculated in the first part of this task. But since ^{12}C and ^{16}O have the same velocity, conservation of momentum reduced to:

$$\left[m(^{16}\text{O}) - m(^{12}\text{C}) \right] v(^{16}\text{O}) = m(^{58}\text{Ni}) v(^{58}\text{Ni}) \quad (24)$$

Now we can easily find the kinetic energy of ^{58}Ni :

$$\begin{aligned} E_k(^{58}\text{Ni}) &= \frac{m(^{58}\text{Ni}) v^2(^{58}\text{Ni})}{2} = \frac{[m(^{58}\text{Ni}) v(^{58}\text{Ni})]^2}{2m(^{58}\text{Ni})} = \\ &= \frac{[[m(^{16}\text{O}) - m(^{12}\text{C})] v(^{16}\text{O})]^2}{2m(^{58}\text{Ni})} = \\ &= E_k(^{16}\text{O}) \frac{[m(^{16}\text{O}) - m(^{12}\text{C})]^2}{m(^{58}\text{Ni}) m(^{16}\text{O})} \end{aligned} \quad (25)$$

and finally the excitation energy of ^{58}Ni :

$$\begin{aligned} E_x(^{58}\text{Ni}) &= E_k(^{16}\text{O}) + Q - E_k(^{12}\text{C}) - E_k(^{58}\text{Ni}) = \\ &= E_k(^{16}\text{O}) + Q - \frac{m(^{12}\text{C}) v^2(^{16}\text{O})}{2} - E_k(^{16}\text{O}) \frac{[m(^{16}\text{O}) - m(^{12}\text{C})]^2}{m(^{58}\text{Ni}) m(^{16}\text{O})} = \\ &= Q + E_k(^{16}\text{O}) - E_k(^{16}\text{O}) \cdot \frac{m(^{12}\text{C})}{m(^{16}\text{O})} - E_k(^{16}\text{O}) \frac{[m(^{16}\text{O}) - m(^{12}\text{C})]^2}{m(^{58}\text{Ni}) m(^{16}\text{O})} = \\ &= Q + E_k(^{16}\text{O}) \left[1 - \frac{m(^{12}\text{C})}{m(^{16}\text{O})} - \frac{[m(^{16}\text{O}) - m(^{12}\text{C})]^2}{m(^{58}\text{Ni}) m(^{16}\text{O})} \right] = \\ &= Q + E_k(^{16}\text{O}) \frac{[m(^{16}\text{O}) - m(^{12}\text{C})] \cdot [m(^{58}\text{Ni}) - m(^{16}\text{O}) + m(^{12}\text{C})]}{m(^{58}\text{Ni}) m(^{16}\text{O})} \end{aligned} \quad (26)$$

Note that the first bracket in numerator is approximately equal to the mass of transferred particle (the ^4He nucleus), while the second one is approximately equal to the mass of target nucleus ^{54}Fe . Inserting the numbers we get:

$$\begin{aligned} E_x(^{58}\text{Ni}) &= -0.761 + 50 \cdot \frac{(15.99491 - 12)(57.93535 - 15.99491 + 12)}{57.93535 \cdot 15.99491} = \\ &= 10.866 \text{ MeV} \end{aligned} \quad (27)$$

Relativistic solution

In the relativistic version, solution is found starting from the following pair of equations (the first one is the law of conservation of energy and the second one the law of conservation of momentum):

$$m(^{54}\text{Fe}) \cdot c^2 + \frac{m(^{16}\text{O}) \cdot c^2}{\sqrt{1 - v^2(^{16}\text{O})/c^2}} = \frac{m(^{12}\text{C}) \cdot c^2}{\sqrt{1 - v^2(^{12}\text{C})/c^2}} + \frac{m^*(^{58}\text{Ni}) \cdot c^2}{\sqrt{1 - v^2(^{58}\text{Ni})/c^2}} \quad (28)$$

$$\frac{m(^{16}\text{O}) \cdot v(^{16}\text{O})}{\sqrt{1-v^2(^{16}\text{O})/c^2}} = \frac{m(^{12}\text{C}) \cdot v(^{12}\text{C})}{\sqrt{1-v^2(^{12}\text{C})/c^2}} + \frac{m^*(^{58}\text{Ni}) \cdot v(^{58}\text{Ni})}{\sqrt{1-v^2(^{58}\text{Ni})/c^2}}$$

All the masses in the equations are the rest masses; the ^{58}Ni is NOT in its ground-state, but in one of its excited states (having the mass denoted with m^*). Since ^{12}C and ^{16}O have the same velocity, this set of equations reduces to:

$$m(^{54}\text{Fe}) + \frac{m(^{16}\text{O}) - m(^{12}\text{C})}{\sqrt{1-v^2(^{16}\text{O})/c^2}} = \frac{m^*(^{58}\text{Ni})}{\sqrt{1-v^2(^{58}\text{Ni})/c^2}} \quad (29)$$

$$\frac{(m(^{16}\text{O}) - m(^{12}\text{C})) \cdot v(^{16}\text{O})}{\sqrt{1-v^2(^{16}\text{O})/c^2}} = \frac{m^*(^{58}\text{Ni}) \cdot v(^{58}\text{Ni})}{\sqrt{1-v^2(^{58}\text{Ni})/c^2}}$$

Dividing the second equation with the first one gives:

$$v(^{58}\text{Ni}) = \frac{(m(^{16}\text{O}) - m(^{12}\text{C})) \cdot v(^{16}\text{O})}{(m(^{16}\text{O}) - m(^{12}\text{C})) + m(^{54}\text{Fe})\sqrt{1-v^2(^{16}\text{O})/c^2}} \quad (30)$$

The velocity of projectile can be calculated from its energy:

$$E_{kin} (^{16}\text{O}) = \frac{m(^{16}\text{O}) \cdot c^2}{\sqrt{1-v^2(^{16}\text{O})/c^2}} - m(^{16}\text{O}) \cdot c^2 \quad (31)$$

$$\sqrt{1-v^2(^{16}\text{O})/c^2} = \frac{m(^{16}\text{O}) \cdot c^2}{E_{kin} (^{16}\text{O}) + m(^{16}\text{O}) \cdot c^2}$$

$$v^2(^{16}\text{O})/c^2 = 1 - \left(\frac{m(^{16}\text{O}) \cdot c^2}{E_{kin} (^{16}\text{O}) + m(^{16}\text{O}) \cdot c^2} \right)^2$$

$$v(^{16}\text{O}) = \sqrt{1 - \left(\frac{m(^{16}\text{O}) \cdot c^2}{E_{kin} (^{16}\text{O}) + m(^{16}\text{O}) \cdot c^2} \right)^2} \cdot c$$

For the given numbers we get:

$$v(^{16}\text{O}) = \sqrt{1 - \left(\frac{15.99491 \cdot 1.6605 \cdot 10^{-27} \cdot (2.9979 \cdot 10^8)^2}{50 \cdot 1.602 \cdot 10^{-13} + 15.99491 \cdot (2.9979 \cdot 10^8)^2} \right)^2} \cdot c =$$

$$= \sqrt{1 - 0.99666^2} \cdot c = 0.08172 \cdot c = 2.4498 \cdot 10^7 \text{ km/s} \quad (32)$$

Now we can calculate:

$$v(^{58}\text{Ni}) = \frac{(15.99491 - 12.0) \cdot 2.4498 \cdot 10^7 \text{ km/s}}{(15.99491 - 12.0) + 53.93962\sqrt{1 - 0.08172^2}} = 1.6946 \cdot 10^6 \text{ km/s} \quad (33)$$

The mass of ^{58}Ni in its excited state is then:

$$\begin{aligned}
 m^*(^{58}\text{Ni}) &= (m(^{16}\text{O}) - m(^{12}\text{C})) \frac{\sqrt{1 - v^2(^{58}\text{Ni})/c^2}}{\sqrt{1 - v^2(^{16}\text{O})/c^2}} \cdot \frac{v(^{16}\text{O})}{v(^{58}\text{Ni})} = \\
 &= (15.99491 - 12.0) \frac{\sqrt{1 - (1.6945 \cdot 10^6 / 2.9979 \cdot 10^8)^2}}{\sqrt{1 - 0.08172^2}} \cdot \frac{2.4498 \cdot 10^7}{1.6945 \cdot 10^6} \text{ a.m.u.} = \\
 &= 57.9470 \text{ a.m.u.}
 \end{aligned}
 \tag{34}$$

The excitation energy of ^{58}Ni is then:

$$\begin{aligned}
 E_x &= [m^*(^{58}\text{Ni}) - m(^{58}\text{Ni})] \cdot c^2 = (57.9470 - 57.93535) \cdot 1.6605 \cdot 10^{-27} (2.9979 \cdot 10^8)^2 = \\
 &= 2.00722 \cdot 10^{-12} / 1.602 \cdot 10^{-13} \text{ MeV/J} = 10.8636 \text{ MeV}
 \end{aligned}
 \tag{35}$$

The relativistic and non-relativistic results are equal within 2 keV so both can be considered as correct –we can conclude that at the given beam energy, relativistic effects are not important.

Task 5b) For gamma-emission from the static nucleus, laws of conservation of energy and momentum give:

$$\begin{aligned}
 E_x(^{58}\text{Ni}) &= E_\gamma + E_{\text{recoil}} \\
 p_\gamma &= p_{\text{recoil}}
 \end{aligned}
 \tag{36}$$

Gamma-ray and recoiled nucleus have, of course, opposite directions. For gamma-ray (photon), energy and momentum are related as:

$$E_\gamma = p_\gamma \cdot c
 \tag{37}$$

In part a) we have seen that the nucleus motion in this energy range is not relativistic, so we have:

$$E_{\text{recoil}} = \frac{p_{\text{recoil}}^2}{2m(^{58}\text{Ni})} = \frac{p_\gamma^2}{2m(^{58}\text{Ni})} = \frac{E_\gamma^2}{2m(^{58}\text{Ni}) \cdot c^2}
 \tag{38}$$

Inserting this into law of energy conservation Eq. (36), we get:

$$E_x(^{58}\text{Ni}) = E_\gamma + E_{\text{recoil}} = E_\gamma + \frac{E_\gamma^2}{2m(^{58}\text{Ni}) \cdot c^2}
 \tag{39}$$

This reduces to the quadratic equation:

$$E_\gamma^2 + 2m(^{58}\text{Ni})c^2 \cdot E_\gamma + 2m(^{58}\text{Ni})c^2 E_x(^{58}\text{Ni}) = 0 \quad (40)$$

which gives the following solution:

$$E_\gamma = \frac{-2m(^{58}\text{Ni})c^2 + \sqrt{4(m(^{58}\text{Ni})c^2)^2 + 8m(^{58}\text{Ni})c^2 E_x(^{58}\text{Ni})}}{2} = \sqrt{(m(^{58}\text{Ni})c^2)^2 + 2m(^{58}\text{Ni})c^2 E_x(^{58}\text{Ni})} - m(^{58}\text{Ni})c^2 \quad (41)$$

Inserting numbers gives:

$$E_\gamma = 10.8633 \text{ MeV} \quad (42)$$

The equation (37) can also be reduced to an approximate equation before inserting numbers:

$$E_\gamma = E_x \left(1 - \frac{E_x}{2m(^{58}\text{Ni})c^2} \right) = 10.8633 \text{ MeV} \quad (43)$$

The recoil energy is now easily found as:

$$E_{\text{recoil}} = E_x(^{58}\text{Ni}) - E_\gamma = 1.1 \text{ keV} \quad (44)$$

Due to the fact that nucleus emitting gamma-ray (^{58}Ni) is moving with the high velocity, the energy of gamma ray will be changed because of the Doppler effect. The relativistic Doppler effect (when source is moving towards observer/detector) is given with this formula:

$$f_{\text{detector}} = f_{\gamma, \text{emitted}} \sqrt{\frac{1+\beta}{1-\beta}} \quad (45)$$

and since there is a simple relation between photon energy and frequency ($E=hf$), we get the similar expression for energy:

$$E_{\text{detector}} = E_{\gamma, \text{emitted}} \sqrt{\frac{1+\beta}{1-\beta}} \quad (46)$$

where $\beta=v/c$ and v is the velocity of emitter (the ^{58}Ni nucleus). Taking the calculated value of the ^{58}Ni velocity (equation 29) we get:

$$E_{\text{detector}} = E_{\gamma, \text{emitted}} \sqrt{\frac{1+\beta}{1-\beta}} = 10.863 \sqrt{\frac{1+0.00565}{1-0.00565}} = 10.925 \text{ MeV} \quad (47)$$

Solution: Exp. problem 1

Task 1			Points
(a)	m[g]	R₀[mm]	0.95
	21	40.5	
	25	39.5	
	29	38.5	
	31	37.5	
	34	36.5	
	36	35.5	
	39	34.5	
	43	33.5	
	46	32.5	
	50	31.5	
	53	30.5	
	57	29.5	
	62	28.5	
	67	27.5	
	73	26.5	
	79	25.5	
	86	24.5	
	94	23.5	
	102	22.5	
	113	21.5	
	124	20.5	
	137	19.5	
	150	18.5	
	168	17.5	
	189	16.5	
	212	15.5	
	274	13.5	
	417	10.5	

Task 1		Points																																																										
(a)	<table border="1"><thead><tr><th>m[g]</th><th>R₀[mm]</th></tr></thead><tbody><tr><td>40</td><td>29.9</td></tr><tr><td>42</td><td>29.8</td></tr><tr><td>45</td><td>29.6</td></tr><tr><td>47</td><td>29.4</td></tr><tr><td>50</td><td>29.3</td></tr><tr><td>52</td><td>29.1</td></tr><tr><td>54</td><td>28.9</td></tr><tr><td>57</td><td>28.8</td></tr><tr><td>59</td><td>28.6</td></tr><tr><td>61</td><td>28.4</td></tr><tr><td>64</td><td>28.3</td></tr><tr><td>71</td><td>27.8</td></tr><tr><td>78</td><td>27.3</td></tr><tr><td>92</td><td>26.3</td></tr><tr><td>105</td><td>25.3</td></tr><tr><td>118</td><td>24.3</td></tr><tr><td>129</td><td>23.3</td></tr><tr><td>143</td><td>22.3</td></tr><tr><td>157</td><td>21.3</td></tr><tr><td>171</td><td>20.3</td></tr><tr><td>189</td><td>19.3</td></tr><tr><td>211</td><td>18.3</td></tr><tr><td>235</td><td>17.3</td></tr><tr><td>259</td><td>16.3</td></tr><tr><td>293</td><td>15.3</td></tr><tr><td>336</td><td>14.3</td></tr><tr><td>386</td><td>13.3</td></tr><tr><td>449</td><td>12.3</td></tr></tbody></table>	m[g]	R₀[mm]	40	29.9	42	29.8	45	29.6	47	29.4	50	29.3	52	29.1	54	28.9	57	28.8	59	28.6	61	28.4	64	28.3	71	27.8	78	27.3	92	26.3	105	25.3	118	24.3	129	23.3	143	22.3	157	21.3	171	20.3	189	19.3	211	18.3	235	17.3	259	16.3	293	15.3	336	14.3	386	13.3	449	12.3	0.95
m[g]	R₀[mm]																																																											
40	29.9																																																											
42	29.8																																																											
45	29.6																																																											
47	29.4																																																											
50	29.3																																																											
52	29.1																																																											
54	28.9																																																											
57	28.8																																																											
59	28.6																																																											
61	28.4																																																											
64	28.3																																																											
71	27.8																																																											
78	27.3																																																											
92	26.3																																																											
105	25.3																																																											
118	24.3																																																											
129	23.3																																																											
143	22.3																																																											
157	21.3																																																											
171	20.3																																																											
189	19.3																																																											
211	18.3																																																											
235	17.3																																																											
259	16.3																																																											
293	15.3																																																											
336	14.3																																																											
386	13.3																																																											
449	12.3																																																											

Task 1

Points

(b)

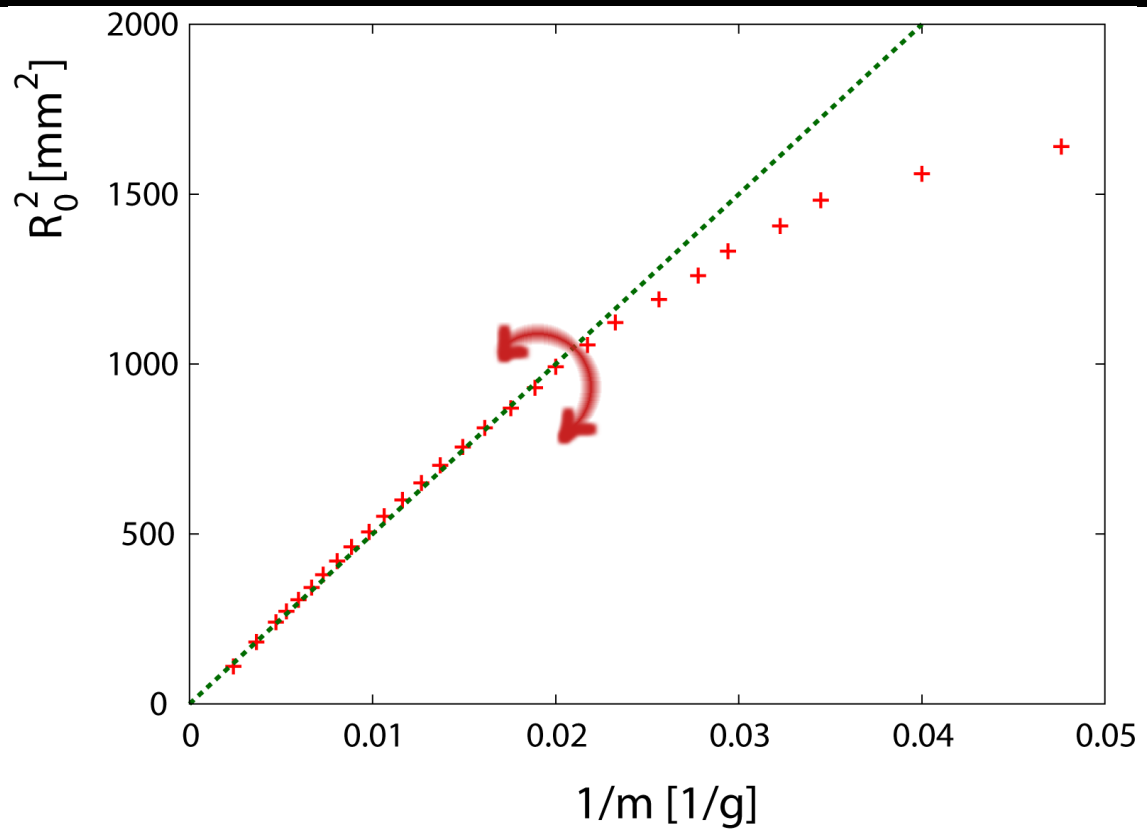

$$a = 50000 \text{ g mm}^2$$

1.4

Task 1

Points

(b)

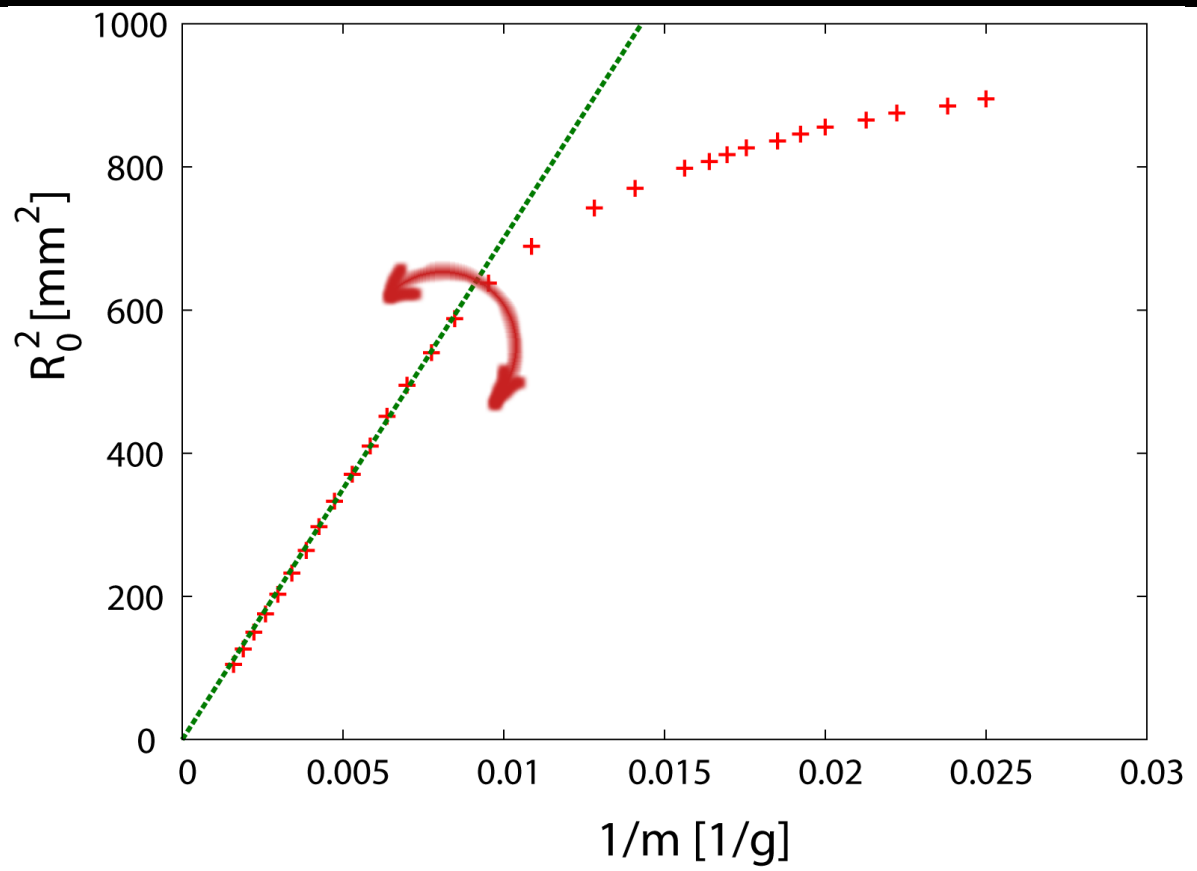

$$a = 70000 \text{ g mm}^2$$

1.4

Task 1		Points																																																										
(b)	$\kappa = \frac{2ag}{\pi l} = 1.5 \text{ mJ}$	0.5																																																										
	$\kappa = \frac{2ag}{\pi l} = 1.5 \text{ mJ}$	0.5																																																										
	$\frac{R_0}{R_c} \leq 0.70$ $\frac{R_0}{R_c} \leq 0.77$	0.5																																																										
Task 2		Points																																																										
<table border="1"> <thead> <tr> <th>m[g]</th> <th>R₀[mm]</th> </tr> </thead> <tbody> <tr><td>6</td><td>42.5</td></tr> <tr><td>7</td><td>42.</td></tr> <tr><td>9</td><td>41.</td></tr> <tr><td>12</td><td>39.5</td></tr> <tr><td>15</td><td>37.5</td></tr> <tr><td>19</td><td>35.5</td></tr> <tr><td>20</td><td>34.5</td></tr> <tr><td>21</td><td>33.5</td></tr> <tr><td>24</td><td>32.5</td></tr> <tr><td>26</td><td>31.5</td></tr> <tr><td>28</td><td>30.5</td></tr> <tr><td>30</td><td>29.5</td></tr> <tr><td>33</td><td>28.5</td></tr> <tr><td>36</td><td>27.5</td></tr> <tr><td>40</td><td>26.5</td></tr> <tr><td>44</td><td>25.5</td></tr> <tr><td>48</td><td>24.5</td></tr> <tr><td>53</td><td>23.5</td></tr> <tr><td>58</td><td>22.5</td></tr> <tr><td>66</td><td>21.5</td></tr> <tr><td>73</td><td>20.5</td></tr> <tr><td>82</td><td>19.5</td></tr> <tr><td>92</td><td>18.5</td></tr> <tr><td>104</td><td>17.5</td></tr> <tr><td>116</td><td>16.5</td></tr> <tr><td>127</td><td>15.5</td></tr> <tr><td>145</td><td>14.5</td></tr> <tr><td>168</td><td>13.5</td></tr> </tbody> </table>		m[g]	R ₀ [mm]	6	42.5	7	42.	9	41.	12	39.5	15	37.5	19	35.5	20	34.5	21	33.5	24	32.5	26	31.5	28	30.5	30	29.5	33	28.5	36	27.5	40	26.5	44	25.5	48	24.5	53	23.5	58	22.5	66	21.5	73	20.5	82	19.5	92	18.5	104	17.5	116	16.5	127	15.5	145	14.5	168	13.5	0.9
m[g]	R ₀ [mm]																																																											
6	42.5																																																											
7	42.																																																											
9	41.																																																											
12	39.5																																																											
15	37.5																																																											
19	35.5																																																											
20	34.5																																																											
21	33.5																																																											
24	32.5																																																											
26	31.5																																																											
28	30.5																																																											
30	29.5																																																											
33	28.5																																																											
36	27.5																																																											
40	26.5																																																											
44	25.5																																																											
48	24.5																																																											
53	23.5																																																											
58	22.5																																																											
66	21.5																																																											
73	20.5																																																											
82	19.5																																																											
92	18.5																																																											
104	17.5																																																											
116	16.5																																																											
127	15.5																																																											
145	14.5																																																											
168	13.5																																																											

Task 2

Points

0.9

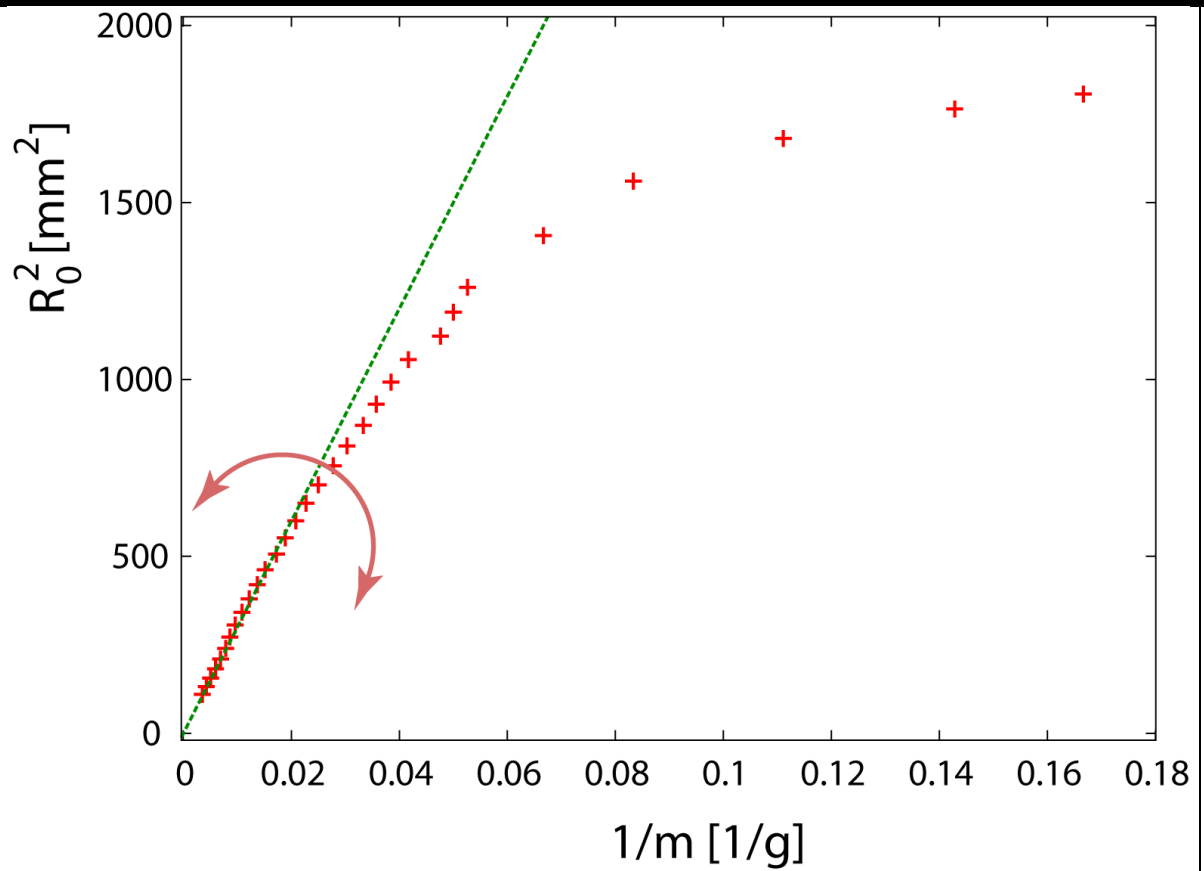

$$a = 27000 \text{ g mm}^2$$

Task 2		Points
	$\mathcal{K} = 0.8 \text{ mJ}$	1.0
Task 3		Points
	Young modulus of the blue foil: $Y = 2.0 \text{ GPa}$	0.6
	Young modulus of the colorless foil: $Y = 2.5 \text{ GPa}$	0.4
Total:		10

Solution - Exp. Problem 2

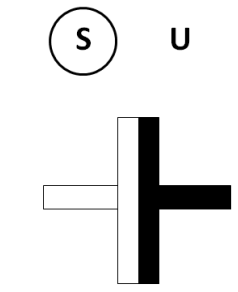
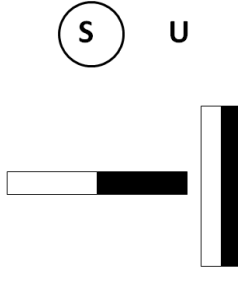
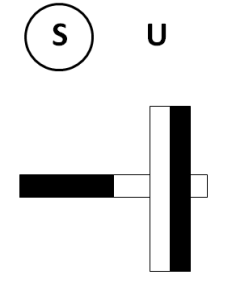
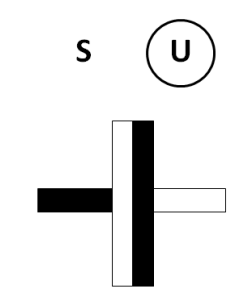
Task 1		Points
		0.25
		0.45
		0.45
		0.45

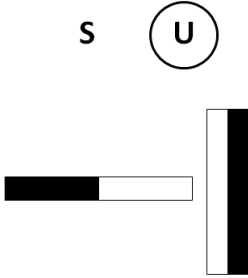
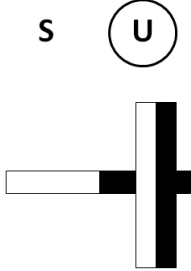
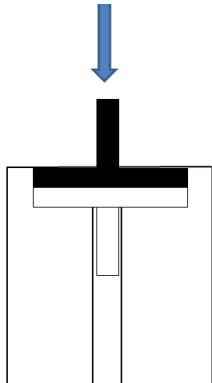
		0.45																		
		0.45																		
Task 2		Points																		
	<p>Symmetries that should be utilized in the measurements:</p> <table border="1" data-bbox="336 976 1110 1126"> <tr> <td>$F_{\uparrow\downarrow}(z) = -F_{\uparrow\downarrow}(-z)$</td> </tr> <tr> <td>$F_{\uparrow\downarrow}(z) = -F_{\uparrow\uparrow}(z)$</td> </tr> <tr> <td>From the two above one gets also $F_{\uparrow\uparrow}(z) = -F_{\uparrow\uparrow}(-z)$</td> </tr> </table>	$F_{\uparrow\downarrow}(z) = -F_{\uparrow\downarrow}(-z)$	$F_{\uparrow\downarrow}(z) = -F_{\uparrow\uparrow}(z)$	From the two above one gets also $F_{\uparrow\uparrow}(z) = -F_{\uparrow\uparrow}(-z)$	0,6															
$F_{\uparrow\downarrow}(z) = -F_{\uparrow\downarrow}(-z)$																				
$F_{\uparrow\downarrow}(z) = -F_{\uparrow\uparrow}(z)$																				
From the two above one gets also $F_{\uparrow\uparrow}(z) = -F_{\uparrow\uparrow}(-z)$																				
	<p>By using the setup as it is, the whole curve can be measured by starting the measurements from three stable equilibrium points; the equilibrium point (z_0) can be measured also by using the setup.</p> <p>Configuration:</p>  <p>Measurements:</p> <table border="1" data-bbox="336 1787 764 2022"> <thead> <tr> <th>$z_0=0\text{mm}$</th> <th>m [g]</th> <th>Δz [mm]</th> </tr> </thead> <tbody> <tr> <td></td> <td>0</td> <td>0</td> </tr> <tr> <td></td> <td>31</td> <td>1</td> </tr> <tr> <td></td> <td>55</td> <td>2</td> </tr> <tr> <td></td> <td>75</td> <td>3</td> </tr> <tr> <td></td> <td>97</td> <td>4</td> </tr> </tbody> </table>	$z_0=0\text{mm}$	m [g]	Δz [mm]		0	0		31	1		55	2		75	3		97	4	0,8
$z_0=0\text{mm}$	m [g]	Δz [mm]																		
	0	0																		
	31	1																		
	55	2																		
	75	3																		
	97	4																		

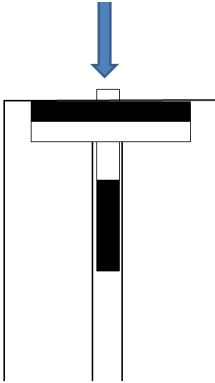
	<table> <tbody> <tr><td>119</td><td>5</td></tr> <tr><td>140</td><td>6</td></tr> <tr><td>158</td><td>7</td></tr> <tr><td>171</td><td>8</td></tr> <tr><td>170</td><td>9</td></tr> <tr><td>118</td><td>10</td></tr> <tr><td>85</td><td>10,25</td></tr> <tr><td>50</td><td>10,5</td></tr> <tr><td>10</td><td>10,75</td></tr> </tbody> </table>	119	5	140	6	158	7	171	8	170	9	118	10	85	10,25	50	10,5	10	10,75																									
119	5																																											
140	6																																											
158	7																																											
171	8																																											
170	9																																											
118	10																																											
85	10,25																																											
50	10,5																																											
10	10,75																																											
	<p>Configuration:</p>  <p>Measurements:</p> <table border="1"> <thead> <tr> <th>$z_0=10.8\text{mm}$</th> <th>m [g]</th> <th>Δz [mm]</th> </tr> </thead> <tbody> <tr><td></td><td>0</td><td>0</td></tr> <tr><td></td><td>233</td><td>1</td></tr> <tr><td></td><td>538</td><td>2</td></tr> <tr><td></td><td>927</td><td>3</td></tr> <tr><td></td><td>996</td><td>3,5</td></tr> <tr><td></td><td>1124</td><td>4</td></tr> <tr><td></td><td>1154</td><td>4,5</td></tr> <tr><td></td><td>1213</td><td>5</td></tr> <tr><td></td><td>1212</td><td>5,5</td></tr> <tr><td></td><td>1120</td><td>6</td></tr> <tr><td></td><td>873</td><td>6,5</td></tr> <tr><td></td><td>284</td><td>7</td></tr> <tr><td></td><td>36</td><td>7,5</td></tr> </tbody> </table>	$z_0=10.8\text{mm}$	m [g]	Δz [mm]		0	0		233	1		538	2		927	3		996	3,5		1124	4		1154	4,5		1213	5		1212	5,5		1120	6		873	6,5		284	7		36	7,5	0,8
$z_0=10.8\text{mm}$	m [g]	Δz [mm]																																										
	0	0																																										
	233	1																																										
	538	2																																										
	927	3																																										
	996	3,5																																										
	1124	4																																										
	1154	4,5																																										
	1213	5																																										
	1212	5,5																																										
	1120	6																																										
	873	6,5																																										
	284	7																																										
	36	7,5																																										

Configuration:

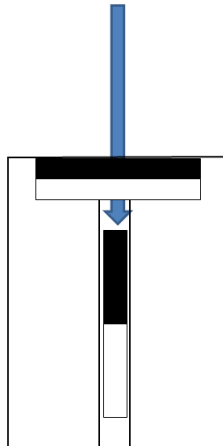

0,8

Measurements:

$z_0=18.6\text{mm}$	m [g]	Δz [mm]
	0	0
	116	1
	170	2
	186	3
	184	4
	169	5
	150	6
	116	8
	89	10
	67	12
	53	14
	36	16
	27	18
	23	20
	14	22
	9	24
	5	26
	3	28

Task 3

Points

Due to symmetry, it is sufficient to plot e.g., the following graph in detail:

2

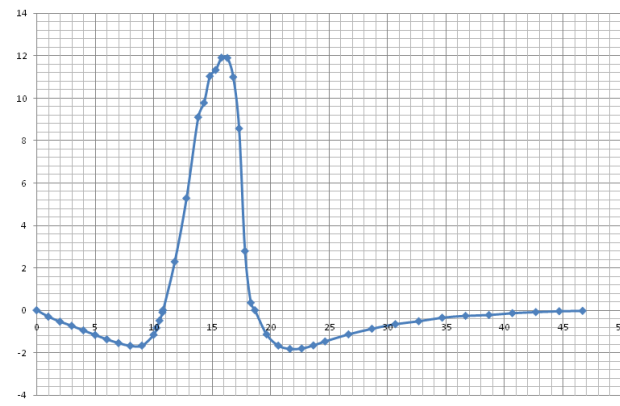
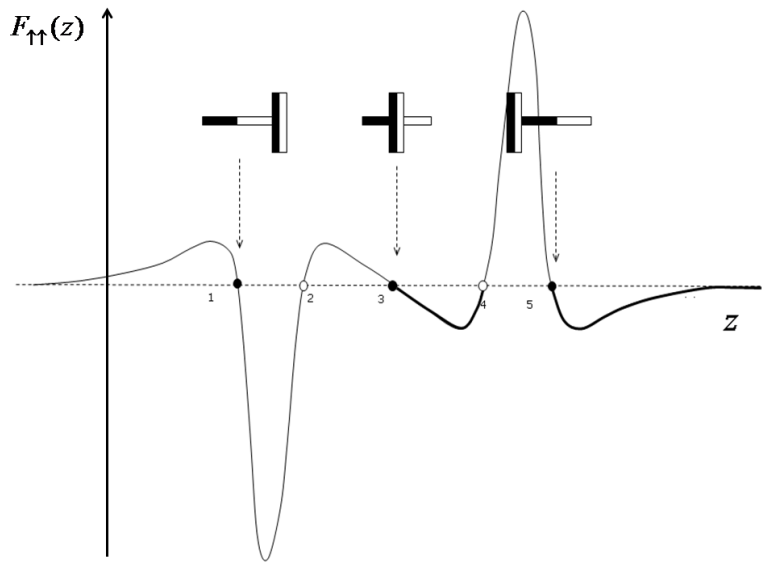
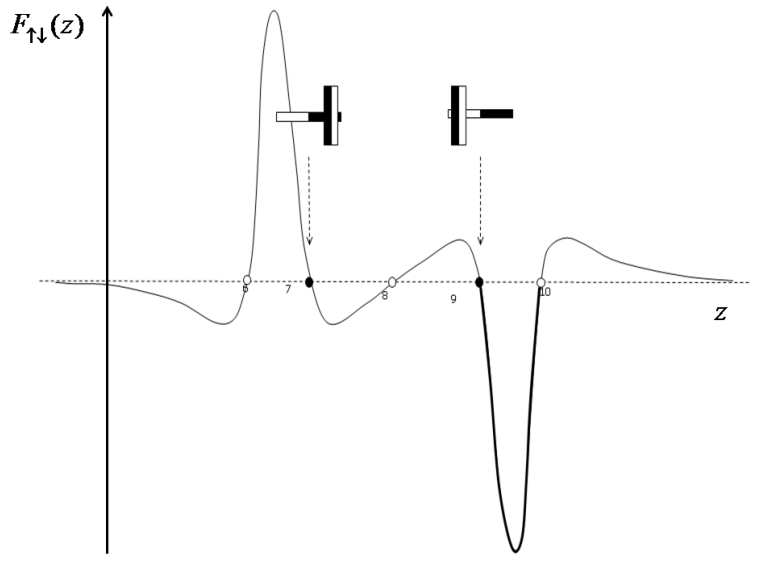
	<p>$F_{\uparrow\uparrow}(z)$ [N]</p>  <p style="text-align: right;">z [mm]</p>	
	<p>$F_{\uparrow\uparrow}(z)$</p>  <p style="text-align: right;">z</p>	<p>1</p>
	<p>$F_{\uparrow\downarrow}(z)$</p>  <p style="text-align: right;">z</p>	<p>1</p>

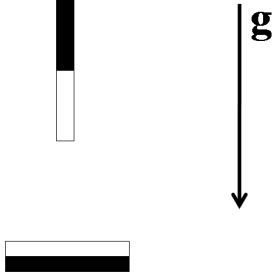
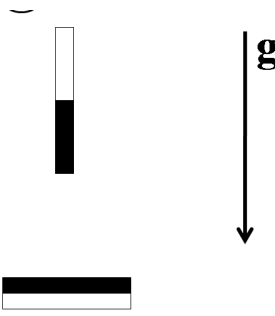
		0,5
	<p>OR</p> 	
Total:		10.0